



SM-2

Automatic Crew-Overboard (COB) Marker Light

MARKER LIGHT



THE SCIENCE OF SURVIVAL



SM-2



Automatic Crew-Overboard (COB) Marker Light

With 70,000 peak candlepower, this high intensity Xenon strobe clearly marks a crew-overboard site with each brilliant flash. It automatically rights itself and activates when in the water and begins strobing, operating for up to 60 hours on a 6-volt lantern battery. Perfect for commercial marine, petro-marine, cruisers and any application needing a reliable COB light.

The SM-2 is the industry standard for buoy lights. Its durability is put to the test every day on ships and oil rigs around the

world and is the choice of the United States Navy and Coast Guard. ACR has long solved the issue of condensation in buoy lights which is a common occurrence on some other brands.

The supplied mounting bracket holds the SM-2 secure in the roughest of conditions but it is still readily accessible when needed in an emergency. With its easily replaceable 6 volt lantern battery power source, the SM-2 will give years of service and be ready when called upon.

- Upgraded, polycarbonate blend case is extremely durable; withstands vigorous use [drop-tested 30 m]
- UV, temperature, and chemical-resistant
- High intensity Xenon strobe gives 360° visibility for more than 4.8 km

SPECIFICATIONS

Product Number	3940.1
Size	35 x 12 cm
Weight	794 g 1.13 kg with battery
Material	UV stable polycarbonate blend
Color	International orange
Operation	Throw unit overboard or turn upright and light will begin to work
Waterproof	Drop tested 33 m into water
Battery Type	6V Lantern style battery
Beam Angle	Omnidirectional 360°
Visibility	360° visibility for over 4.8 km
Flash Rate	60/minute
Lamp	Xenon flash tube
Certification	Complies with IMO/SOLAS/LSA Code; USCG 161.010 & USCG 161.110 approved; Tested to UL 1196
Accessories	<ul style="list-style-type: none"> • Bulkhead bracket (P/N 9438.1) • Top cap and pole strobe assembly (P/N 9021.1) • Repair kit (P/N 9286) • Stainless Steel Lifeline Bracket (P/N 9566)
Limited Warranty	1 year

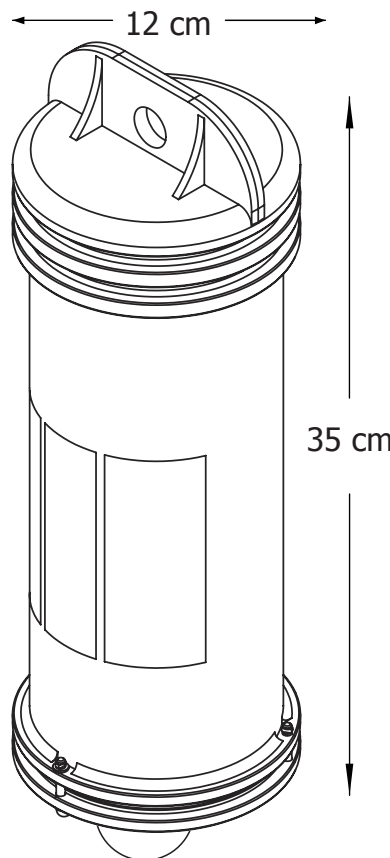

A Matter of Balance

Marker lights, by design, need to float upright for maximum visibility. The 6 volt lantern batteries provide the ballast for these lights. Although batteries may be the same size, the different chemistries cause them to have varying weights. It is imperative that only the 6 volt battery models suggested are used. Too little ballast and the light will lie on its side and be ineffective; too much weight and the light may sink. If there are any doubts to the appropriate weight of the battery, test the light by placing it in shallow water. If it floats upright, it is good, however, if the SM-2 sinks, the battery is too heavy.

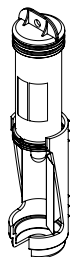
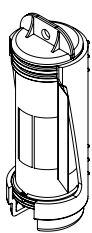

Suggested Battery Types

Screw Terminal Batteries: ANSI/NEDA: 915, 915C, 915D, 915AC Duracell: M915, PC915; Rayovac: 942, 944 ; Eveready: 510S

Optional Stainless Steel Lifeline Bracket

P/N 9566
Attaches to SM-2 as a mounting bracket to sailboats fitted with a lifeline Bracket does not comply with IMO/SOLAS/USCG due to bracket configuration



Distributed by:

www.ACRARTEX.com

For further information please contact: