

STAYING TRUE TO YOUR COURSE.

Accu-Steer, Inc.

HIGH-PERFORMANCE HYDRAULIC CONTROL OF STEERING SYSTEMS

Defining **Reliability** through form and function.

(Each unit is completely tested after assembly)

Dedicated to quality high-performance hydraulic control of steering systems for yachts and commercial vessels

Medium-Duty Hydraulic Reversing Pump Unit **HRP100**

The Accu-Steer HRP100 pump set is designed to interface hydraulic steering systems with autopilot or electric steering control systems. The output flow from the pump set determines the speed of the rudder. The output flow of the HRP100 is adjustable between 0 and 3.5 cu. in. per second. The pump has built-in pressure relief valves, which are factory set at 500 psi. This pump is recommended for medium-duty applications on hydraulic steering systems that are 50 cu. in. or smaller in volume. The compact and rugged construction provides for easy installation and long life operation. This pump model will interface with most marine autopilot systems. *Available in 12 VDC or 24 VDC.*

FEATURES

- Adjustable flow control
- Pressure relief
- High temperature windings
- Ignition protected (UL1500)
- Heavy-duty, high efficiency drive motor with oversized accessible brush gear and ball bearing construction
- Ideal for new and retrofit applications
- Can be used with most autopilots



Accu-Steer, Inc. • Marina Square • 704 Coho Way • Bellingham, WA 98225

(360) 733-4565, tel • (360) 733-4575, fax • cs@Accu-Steer.com • www.Accu-Steer.com

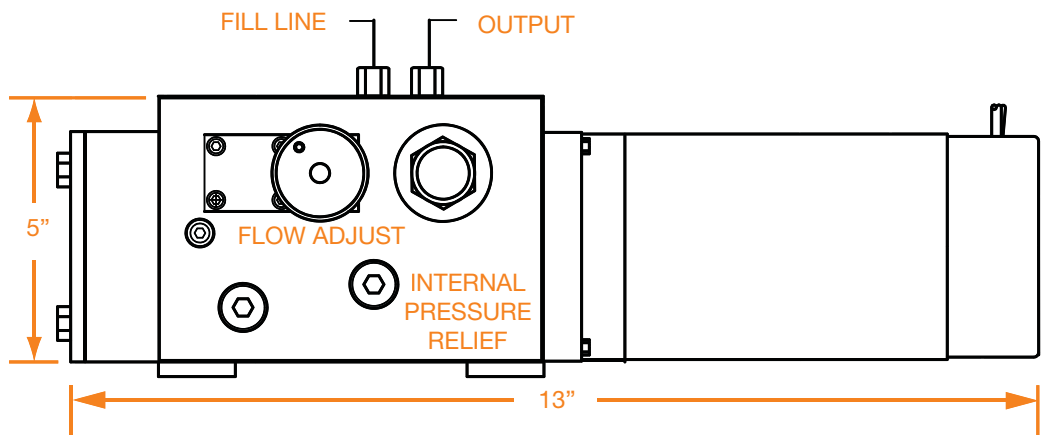
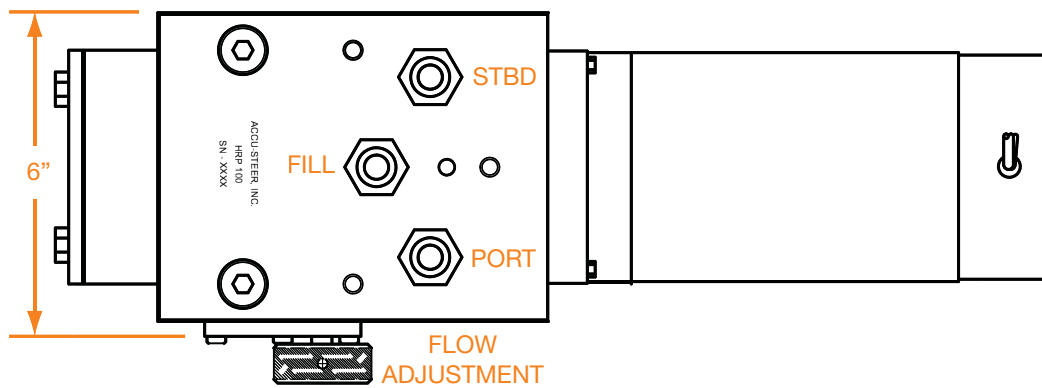
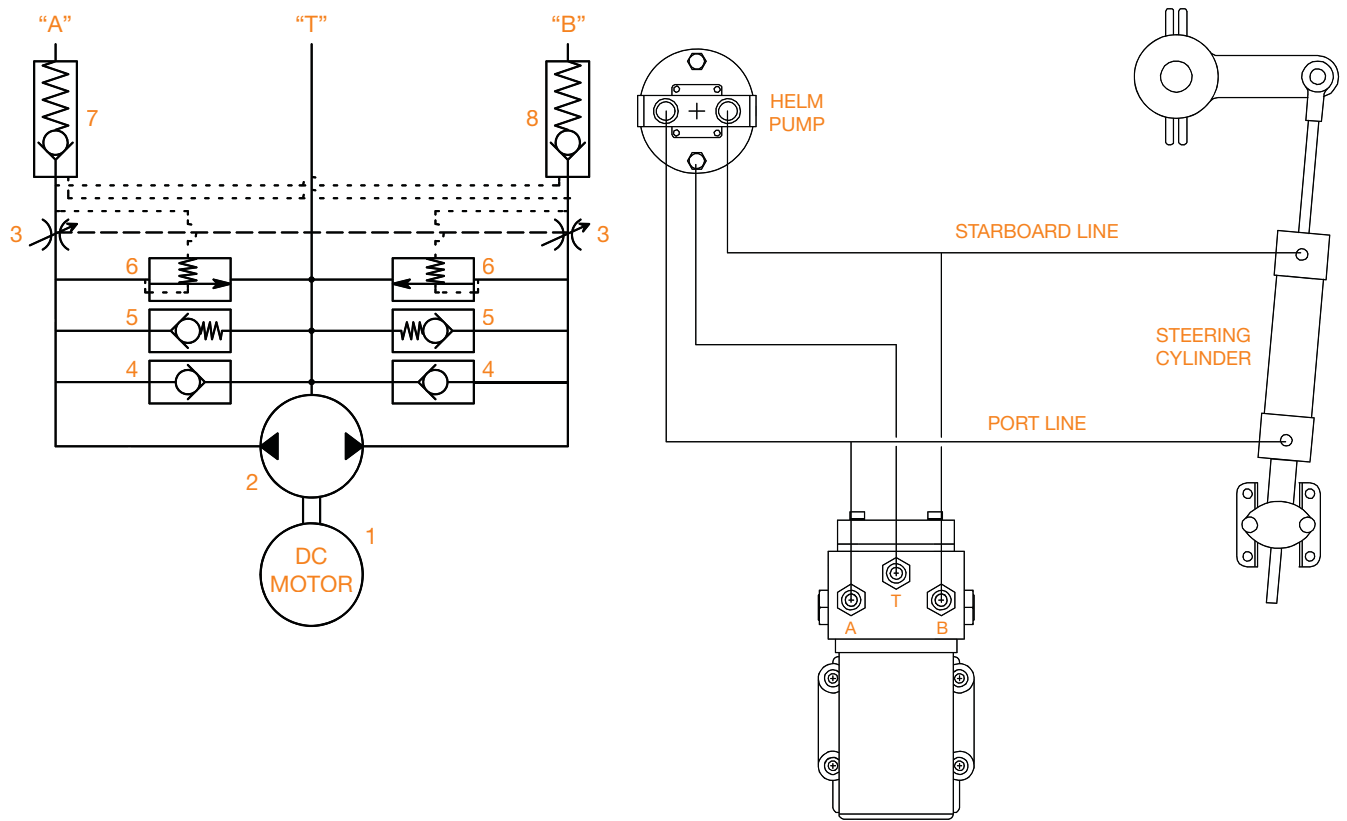

Shipping weight: 18 lbs
 Dimensions: 13" length X 6" width X 5" height