

Congratulations!

You have purchased the finest electronic heading detection system available today. The Sailcomp 103AC digital compass/nav repeater is a microprocessor-controlled system designed to provide you with the heading and navigational information you need for precise navigation. By incorporating a digital computer with our sophisticated fluxgate compass and then adding a nav repeater capability, we have produced a system that combines excellence in performance with maximum reliability and navigational functionality.

For those of you that race, the Sailcomp 103AC's racing features will provide a tactical advantage that will help you win races.

Should you have any questions, comments, or suggestions, please direct them to:

Sailcomp 103AC.
KVH Industries, Inc.
50 Enterprise Center
Middletown, Rhode Island 02842 U.S.A.
tel.: (401) 847-3327
fax: (401) 849-0045

Contents

I. INSTALLATION INSTRUCTIONS

1. Parts List and Tool Requirements	.6
2. Choosing a Location	.7
3. Checking Cable Lengths	.11
4. Mounting	.11
5. Making the Connections	.14
6. Testing	.16
7. Auto-Compensation	.17
Accessing Compensation Display	.19
Alignment Error Adjustment	.21
Disabling Auto-Compensation	.22

II. SAILCOMP 103AC FEATURES

1. Sailcomp Features	.23
2. Damping Control	.23

III. SAILCOMP 103AC MODES

1. Trend Mode	.24
2. Off-Course Mode	.24
3. Nav Repeater Mode	.26
4. Head/Lift Mode	.28
5. Starting Timer Mode	.29
6. Switching Between Modes	.30

IV. RACING WITH THE SAILCOMP

1. Shooting the Wind	.32
2. The Starting Line	.32
3. The Start	.32
4. The First Upwind Leg	.33
5. The Downwind Leg	.35
6. The Second Upwind Leg	.35

V. SPECIAL FUNCTIONS

1. True North Capability	.36
2. Warning Messages:	
"Er1" & "Lo" "bAt"	.37
"snr" & "oor"	.37

VI. APPENDIX

1. Technical Specifications	.38
2. Troubleshooting	.39
3. Wiring Data	.43
4. NMEA 0183 Interface Output	.44
5. Nav Repeater NMEA 0183 Input	.44
6. Compass Notes	.46
7. Warranty & Protection Plan	.47
8. Remote Display Template	.49
9. Remote Keypad Template	.51

Before you begin . . .

Important!

Before you jump into your installation:

1. Please read this manual thoroughly. The correct installation of the Sailcomp 103AC is of utmost importance to its accuracy and precision, and most of all, to your enjoyment of your new electronic compass/nav repeater.

Serious damage, inaccuracies, or loss of warranty can result from incorrect installation.

2. Please send your warranty card back to ensure validation of your warranty.
KVH must have a completed warranty card on file.

I. INSTALLATION INSTRUCTIONS

1. Parts and Tools

There are four components to the standard Sailcomp 103AC. They are:

- Remote Display (w/ 15' cable)
- AutoComp 1000 Sensor Unit (w/ 15' cable & 15' NMEA 0183 cable)
- Junction Box (w/ 10' power cable)

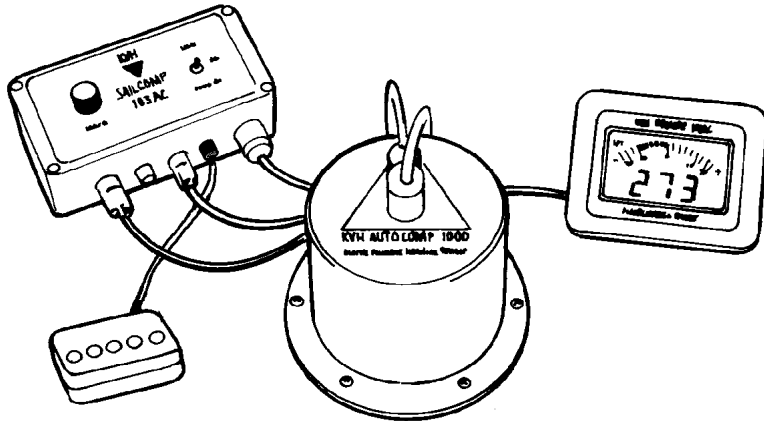

You have also received a bag with mounting hardware. This includes:

Fluxgate Sensor Unit-

- 3 3/4" #10 self-tapping screws

Junction Box-

- 4 3/4" #6 self-thread screws

Remote Display Unit-

- 4 1-3/4" 10-32 studs
- 4 10-32 hex nuts
- 4 #10 washers

Remote Keypad-

- 2 1" #6-32 studs
- 2 #6-32 hex nuts
- 2 #6 washers

Tools Required:

- Drill
- 1/4", 7/64" 5/32" & 9/64" drill bits
- 3/4" drill bit (or hole saw)
- Phillips & flat screwdriver
- 3/8" & 5/32" nut driver (wrench/socket)
- Pencil
- Center punch
- Silicone-type sealant (optional)

Following are detailed step-by-step instructions for correct installation of each component. Make sure that whoever is going to install your Sailcomp 103AC is very familiar with these installation instructions and understands the principles of installation that will ensure that your compass has the precision, convenience and usefulness for which it is designed.

2. Choosing a Location

The first step necessary for installing each component is choosing a good location. **Determining a good location for each component is necessary before mounting to ensure that the provided cable is long enough for your installation.**

Fluxgate Sensor

The greatest advantage of having an electronic compass is that the sensor can be located virtually anywhere on the boat. This ability results in superior compass accuracy because the sensor, which determines the boat's heading, can be placed away from magnetic interference. This removes the limitation of a conventional compass that must be wholly located where the compass rose is visible to the skipper. Ideally, the sensor would be mounted near the center of gravity, but as this is often impractical on many boats, it is not critical.

Note: The Sailcomp 103AC's AutoComp 1000 fluxgate compass sensor does not contain magnets; it measures the earth's magnetic field electronically. Large pieces of metal will distort the earth's flux lines, which the sensor measures, thus causing some error.

To minimize compass errors, select a location for your sensor that is as far as possible from iron, steel or magnetic fields while still being close to the boat's center of gravity. Placing the sensor "center" fore and aft is more important than "center" athwart-ships. We also recommend placing the sensor below the waterline or as close to it as possible.

Each compass is calibrated at the factory, so the more carefully you place the sensor in your boat, the less compensation will be needed. As you look around the boat for a convenient spot that is far from metal or objects that can have strong magnetic fields and is as close to central as possible, make sure to avoid the following spots:

1. **under the sink-** although most sinks are made of stainless steel and will not affect the compass, don't forget that sinks are often used as a good spot to place stray tools, winch handles, metal utensils, cans of food or pots and pans. Result? A variable mass of metal that becomes a moving mass as the boat rolls, causing strange compass swings for no apparent reason. Also note that a porcelain sink is enamelled iron and will cause extreme compass errors.
2. **next to the tool box-** another mass of metal (potentially moving when heeling) that

is often overlooked or not in position when the sensor is installed (because you're using your toolbox when installing it!)

3. **next to the boat motor-** if your boat uses an outboard motor, oftentimes when the spot for the sensor is chosen, the installer forgets that the outboard is a large mass of metal which changes position on the boat from storage location to its position when in use. Check that your sensor's location will not be affected by the motor in either position.
4. **stereo speakers-** contain strong magnets. Placing the sensor near them will cause extreme compass errors.
5. **nav station-** communications equipment in your nav station (VHF or SSB) contain speakers. Placing the sensor within close proximity will result in error.
6. **electric motors-** all electric motors create magnetic fields which can cause significant errors. Since some motors, like refrigerators and bilge pumps, switch on and off at unpredictable times, keep the sensor away from them.
7. **other magnetic compasses-** compasses mounted or stored down below, including some sensors from your other electronic gear, should be kept away from the sensor.

This is a partial list. Use common sense.

A distance of approximately 5 feet is usually sufficient for eliminating any inaccuracies caused by an object that is a source of magnetic interference. If this proves next to impossible on your boat, position the sensor in the best place possible. The Sailcomp 103AC's AutoComp 1000 heading sensor has an **automatic compensation feature**

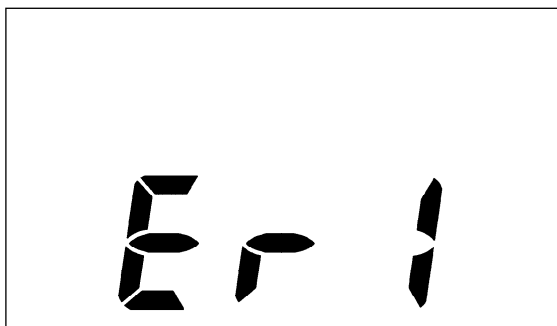

which will compensate out any error as long as there is not so much interference that it overloads the sensor. If your boat has severe magnetic interference problems, it would be prudent to connect and power the system before installing your sensor. If the display flashes an "Er1" message, then there is so much magnetic interference at the sensor's location that the sensor is overloaded and cannot be compensated. The

sensor must be moved to the next best location where you **do not** get the "Er1" message. (see "Er1", pg. 37)

Lastly, the sensor must never be mounted on its side or upside down.

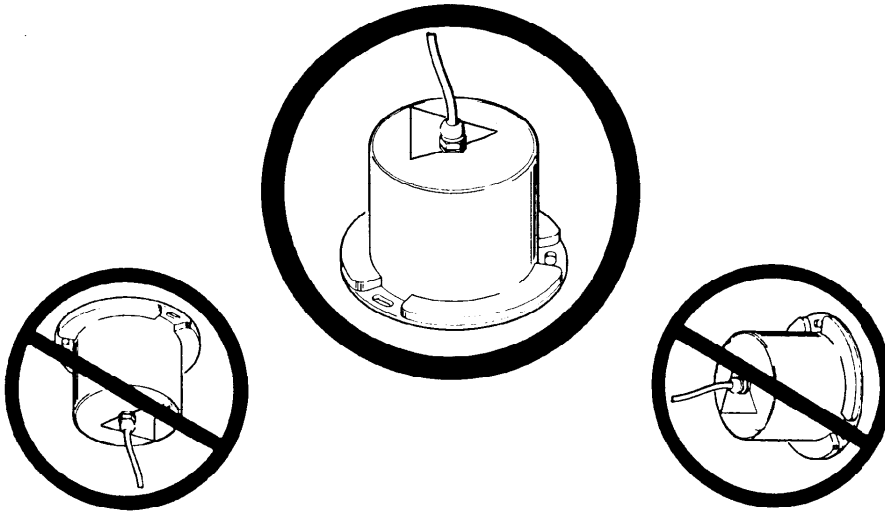

The **top** of the unit has the cables exiting, the words "KVH AUTOCOMP 1000" and a directional "**forward**" arrow. The sensor is internally gimballed to ensure accuracy when the boat heels, but make sure to position the sensor as close to horizontal as possible in relation to the boat, to maximize the use of the gimbal for heeling purposes. If you must mount the sensor against a vertical bulkhead, use a right angle bracket to keep the sensor horizontal. KVH offers an optional sensor bracket for this purpose. *(see Mounting Brackets on price list)*

After finding the best spot for the sensor, select good locations for the junction box, remote display(s), and remote keypad to ensure that the provided cable is long enough for your installation.

Junction Box

The junction box should be placed in a handy, accessible place since it is where:

1. the Sailcomp is turned on/off
2. the damping is adjusted
3. the remote display's light is turned on

Although the junction box is weatherproof and water resistant, it is intended to be mounted in the boat cabin or a weather protected area.

When picking a handy location, make sure that the junction box's two-conductor power cable is able to reach either your boat's 12 volt battery or the electrical panel. If the cable does not reach, use a similar gauge wire to extend it. For boats without a battery or electrical panel, KVH offers a compact, rechargeable 12 volt battery. *(see Batteries on price list)*

Display Unit

The remote display is completely waterproof so you can put it wherever is most convenient and visible for both skipper and crew*. Remember that the display is a repeater and not the sensing device so it is not sensitive to nearby metal or magnets, nor does it contain any metal or magnets. It will not affect other instruments or conventional compasses. Furthermore, the cable is shielded so R.F. interference should be minimal.

There are various spots which other sailors have found to be ideal display locations on their boats. But as with everything, every sailor has his own preference. Here are some often used locations to consider for your installation:

1. **On either side of the bulkhead.** This is usually a good spot on both large and small boats and is quite visible to the helmsman.
2. **On the mast.** This location is very popular among racing boats (35 feet and smaller) as it allows the skipper to keep his head up. This is also a great location because it makes the display visible to the entire crew. KVH offers special single and dual display mast brackets which attach to the sail slot and slide into the mast. The brackets are designed so that the Cunningham and other control lines can be led through them without obstruction. (see Brackets on price list)
3. **Pod mounted on a steering pedestal.** Check with your steering gear manufacturer for details.

When determining the right spot for the display on your boat, keep in mind that **the display must be mounted on a flat surface to avoid unnecessary stress on the watertight seal.** If the display is installed on a surface that is not flat, you can break the seal on the display causing it to leak as the flat display will bend to conform to the curved surface. If your spot is not perfectly flat, use a small block of wood to make a flat mounting plate. If using a Sailcomp mast bracket, this is not a concern as the bracket is specifically designed for the display.

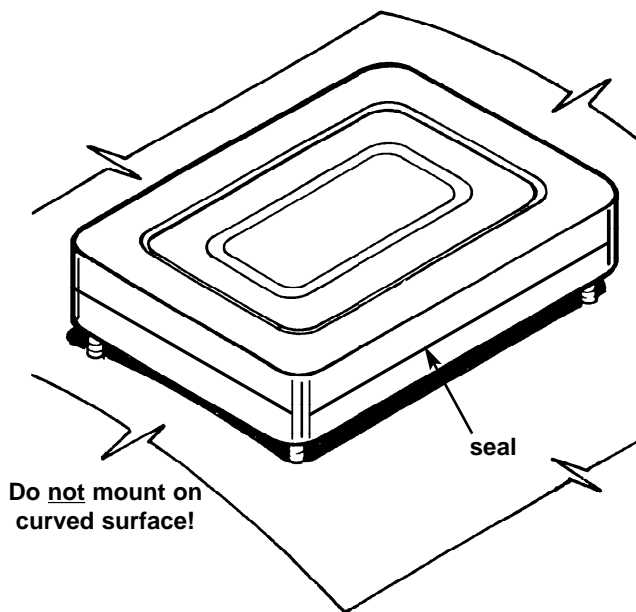

*Up to 4 displays may be added to the system if desired. There is an additional port on the Junction Box for the second display, but a Y-Box Connector is needed for the 3rd and 4th displays. Contact your dealer or KVH.

Remote Keypad

The Remote Keypad is completely waterproof so that it can be mounted wherever is most convenient on your boat*. It can be stacked with the Remote Display on the bulkhead, mounted alone in the cockpit or pod mounted on a steering pedestal for easy access. As the keypad is a flushmount assembly, keep in mind that it should be mounted on a relatively flat surface to avoid unnecessary stress on the watertight seal. If the chosen spot is not perfectly flat, use a small block of wood to make a flat mounting plate.

3. Checking Cable Lengths

At this stage you can determine if the provided cable is sufficient for your needs. If it is not, there are two options:

1. move the critical component to a new location that can be reached by the provided cable.
2. Purchase an extension cable available in 15' and 25' lengths by contacting your local dealer. The system may have up to 100' of extension cable added without losing signal integrity.

Never try to extend or cut the display cable keypad cable or sensor cable. This will not only seriously damage your compass, but will also result in voiding your warranty. The only cables that you can extend yourself are the power cable wires, and the NMEA 0183 interface wires.

4. Mounting

Mounting is as critical to the performance of the system as the right location, so make sure that you or whoever undertakes the task fully understands the objectives.

Sensor Unit

Before mounting the sensor, care must be taken to align the arrow on the top of the sensor and/or the nib protruding from the front of the base of the sensor **parallel with or along the centerline of the boat. The arrow must be facing forward.**

**A second keypad may be added to the system for convenience using a Y-Box Connector. Contact your dealer or KVH.*

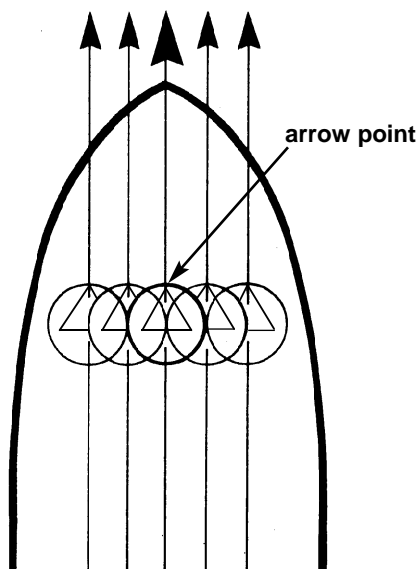

1. Align sensor as shown on left.
2. Drill $9/64$ " holes in the center of the three slots in the base of the sensor.
3. Put one of the provided $3/4$ " #10 self-tapping mounting screws into each of the sensor slots and tighten down.

Never open the main sensor housing as this will void your warranty.

Remote Display Unit

After you have carefully chosen a flat surface for the remote display or have cut a small block of wood to serve as the display's flat mounting plate, follow these instructions carefully:

Note: If it is impossible to reach behind the display to put nuts on the studs, you may have to build a mounting plate that you can screw in from the top.

1. Tape the template provided at the back of this manual to the bulkhead or area where you want to mount the display. Use a center punch on the crosshairs indicated on the template.
2. Drill four $1/4$ " holes for the enclosed 10-32 studs. Then drill the $9/16$ " hole for the cable and connector. The hole must be large enough so that the connector can pass through. **Never try to remove the connector from the cable.**
3. Screw the four 10-32 studs into the back of the display. Check if the display slides easily into the four holes. Correct the hole positions if necessary. **Do not force the display if the holes don't line up!**
4. Remove the display, apply some silicone-type sealant around each hole and push the display all the way in.
5. Use the provided #10 washers and nuts to secure the display. **Hand Tighten Only! Overtightening the screws will damage the display.** A dab of silicone on the threads will keep the nuts from loosening.

Junction Box

Use the four #6 mounting screws to mount the junction box. The screw holes are only accessible from the inside of the junction box. To install:

1. Unscrew the four screws on the top of the junction box and carefully let the cover hang down.
2. Let the cover hang down, trying not to strain the ribbon cable that goes to the power/light switch and the damping control knob which are located in the cover.
3. Mark where the holes are in the box and drill 7/64" holes. Position the junction box over the holes, insert the four #6 screws and tighten securely.
4. Replace the cover and tighten the cover screws. The waterproof seal is reinstated by tightening the cover screws as the mounting screws lie outside the inner rubber gasket.

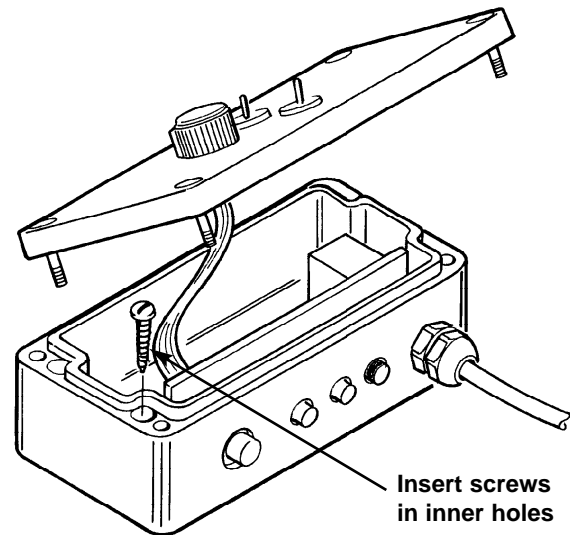

Remote Keypad

After you have carefully chosen a relatively flat surface for the remote keypad, follow these instructions carefully:

Note: If it is impossible to reach underneath the keypad to put nuts on the studs, you may have to build a mounting plate that you can screw in from the top.

1. Tape the template provided at the back of this manual to the spot where you want to mount the keypad. Use a center punch on the crosshairs indicated on the template.
2. Drill the two 5/32" holes for the enclosed 6-32 studs. Then drill the 3/4" hole for the cable. The hole must be large enough so that the cable clamp on the back of the keypad can pass through. **Never try to loosen the cable clamp or remove the connector from the cable.**
3. Screw the two 6-32 studs into the back of the keypad. Check if the keypad slides easily into the two holes. Correct the hole positions if necessary. **Do not force the keypad if the holes don't line up!**
4. Remove the keypad, apply some silicone-type sealant around each hole and push

the cable and keypad in.

5. Use the provided nuts and washers (6-32) to secure the keypad. Do not over-tighten. A dab of silicone on the threads will keep the nuts from loosening.

5. Making the Connections

You are now ready to connect the components together. The connectors are easy to use and unable to be incorrectly fitted. The cables from the sensor, remote display and remote keypad each have a connector that plugs into a port on the front of the junction box. The junction box is configured as shown, right.

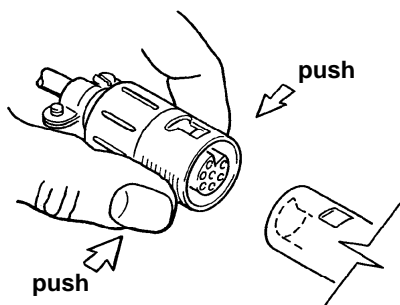
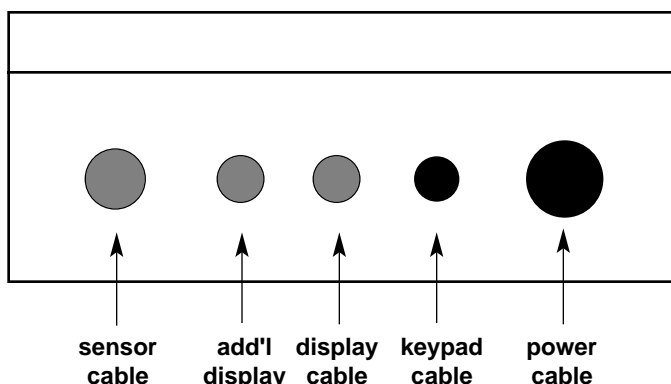

The connectors snap into the ports. You will hear the connector click twice when it is fully snapped onto the port. A connector will only fit onto a port in one position and is removed by pushing in on the "grip" surfaced part of the connector and pulling the connector straight off.

DO NOT TWIST! See illustration, left.

1. Connect the **larger grey 12 pin connector** coming from the sensor unit to the correct port on the junction box. This connector will only fit into one port on the junction box. Push the connector onto the port until it clicks.
2. Connect the cable coming from the remote display to one of the **grey** remote display ports on the junction box. There are two ports, either may be used.*
3. Connect the **black connector** coming from the remote keypad to the **black port** on the junction box.

Now you are ready to connect your system to power, your NMEA 0183 loran/GPS (for the Nav Repeater Mode) as well as interface it to other instruments on your boat, if desired. **The power cable comes out of the junction box** and should be connected as follows:

1. Connect the red wire to a +12V DC power source* which is fused (1 amp). There is no internal fuse in the Sailcomp 103AC to protect it from current overloading.
5. Connect the **black wire** in the power cable to Ground.

There is also a cable coming out of the sensor with 4 wires. These wires connect the Sailcomp to your NMEA 0183 loran or GPS so that you can activate the Nav Repeater Mode and also connect to your other electronics that take NMEA 0183 so that they can access the Sailcomp's heading data. The NMEA lines are used only for interfacing.

Note: Any wires that are not used should be clipped back and insulated from one another.

The wiring is as follows:

Nav Repeater Mode:

brown	NMEA 0183 In(-)
blue	NMEA 0183 In(+)

NMEA 0183 output to instruments that require heading information:

green	NMEA 0183 Out(+)
orange	NMEA 0183 Out(-)
shield	not used(clipped back)
white	not used(clipped back)
red	not used(clipped back)
black	not used(clipped back)

1. The **brown and blue wires** are for connecting a NMEA 0183 loran or GPS to your Sailcomp 103AC so that your Sailcomp 103AC doubles as a nav repeater. If these wires are not used they should be clipped back and wrapped with electrical tape.

To connect the Sailcomp 103AC to your NMEA 0183 loran or GPS:

The configuration of the signal wiring will vary depending on the brand of loran or GPS that you have and what parts come with it.

*Use only a +12V DC power source.

There are three variations:

- A. The loran/GPS may have a **connector wired to a cable** with a pigtail of colored wires. In this case, consult your loran/GPS owner's manual for the wire color code.
- B. The loran/GPS may supply **only a connector** without a pigtail of wires. The NMEA data would then be accessed through the pins on this loran/GPS output connector. Consult your loran/GPS manual or contact your loran/GPS manufacturer directly to obtain the color code and connector pinout.
- C. The loran or GPS may provide **nothing at all**. In this case, you must consult your dealer or loran manufacturer to obtain a plug and the required information.

After you have determined the configuration of your loran's or GPS's signal wiring

:

- a. Connect the **blue wire** (NMEA In(+)) to the loran or GPS' **NMEA Data Wire** (signal side).
 - b. Connect the **brown wire** (NMEA In(-)) to the **Signal Ground** point on the loran or GPS unit.
2. The **green and orange wires** in the power cable are for outputting heading data from your Sailcomp 103AC to your other instruments with NMEA 0183 data format. If these wires are not used they should be clipped back and wrapped with electrical tape.

Optional interface outputs that you may have ordered may also be included in this cable. See separate instructions for any optional interfaces that you have purchased.

Now the unit is ready to power and test.

6. Testing

Testing lets you try out the various functions of the Sailcomp 103AC to make sure everything is working correctly. Furthermore, all compasses must be checked for accuracy once installed on a boat. **The Sailcomp 103AC has an automatic compensation feature which must be performed after installation to ensure that any errors caused by your boat's magnetic field are compensated out.** (*Auto-Compensation, page 17*)

To test the unit:

1. Turn the power **ON** at the junction box.

Every time you turn the unit on, the display goes through a segment test where all segments are lit for 3 seconds.

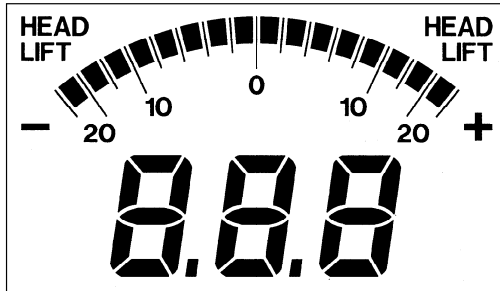

Do not push any buttons during this segment test. If a button is pushed, an unfamiliar display may appear. If so, turn the power off and on again.

2. Check that the Sailcomp 103AC's digital heading readout agrees approximately with a known heading or your boat's recently compensated card compass. If it is not, check to make sure that the sensor is installed top up and that the arrow on the sensor unit is pointing exactly forward. If the Sailcomp's heading is off and you have checked that the sensor unit is installed correctly, this indicates that you have some type of magnetic interference on your boat that must be compensated out of the Sailcomp 103AC.

You are now ready to compensate your Sailcomp 103AC.

7. Auto-Compensation

ALL COMPASSES MUST BE CAREFULLY CHECKED AGAINST KNOWN REFERENCES AND/OR BE COMPENSATED BEFORE BEING USED FOR NAVIGATION.

The Sailcomp 103AC's "auto-compensation" capability automatically measures the surrounding magnetic field distortion and compensates it out, thereby removing the resulting heading errors and giving you a system with better than $\pm 0.5^\circ$ accuracy in most cases.

Although each Sailcomp 103AC is carefully calibrated at the factory during manufacturing, you should intentionally auto-compensate it on your boat after installation so that any errors due to metal and magnetism in your boat are removed.

The Sailcomp 103AC is shipped from the factory with auto-compensation enabled. Every time the vessel completes a 360° turn within the time constraints of the system, the sensor will check its accuracy and recompensate itself if required. Both "hard" (magnetic) and "soft" (iron) errors are automatically compensated by this procedure. This procedure will produce excellent accuracies ($\pm 1^\circ$) even on steel hulls. The Sailcomp 103AC may recompensate itself during normal boat use anytime the boat completes a 360° turn within the time constraints and the resulting data is 25% better than the previously stored data for the sensor.

Important - Read before compensating for the first time!

Intentionally compensating the Sailcomp 103AC at installation is very important to ensuring its accuracy on your boat and is very easy to do. It involves turning your boat through two large, lazy circles at a slow, steady speed (the circles may be slightly out of round or elliptical if necessary). During this procedure, it is critical that the boat remains level and slow enough (idle speed) so that a full circle takes at least 2 minutes to complete. You cannot go too slowly, but if you go too quickly at any point while doing the circles, the sensor is programmed to ignore the data to ensure a perfect compensation.

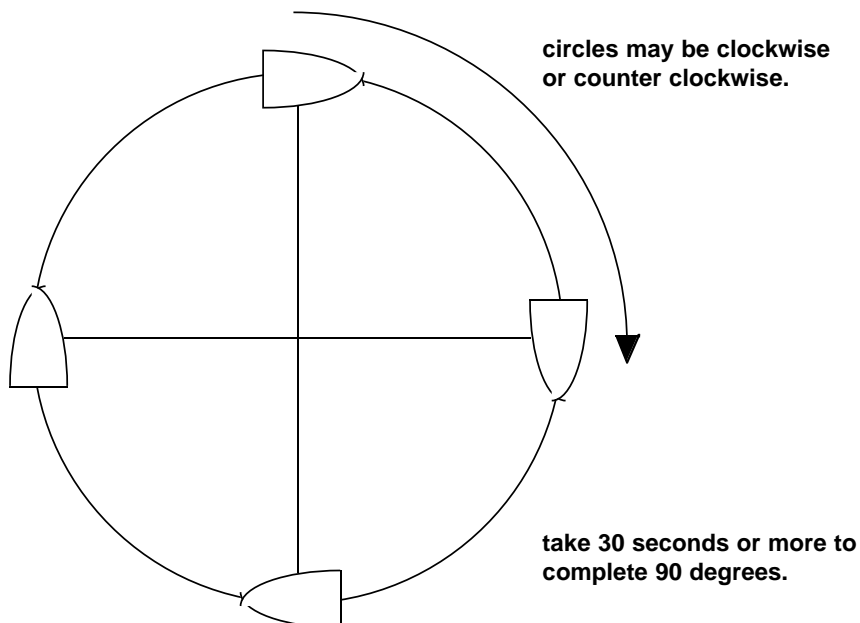

To Compensate the Sailcomp 103AC:

1. Select a calm day and a clear area without too much current or tide. Watch out for excessive pitching and rolling, as this can make your boat turn in surges faster than the Sailcomp 103AC sensor will accept. **This procedure should be done under power, not sail, if possible.**

2. Turn **ON** the Sailcomp 103AC and note the heading so that you will roughly know when you have completed a full circle.
3. There is no Compensation Mode or buttons to push, just steer your boat at a slow, steady speed (idle speed) through a full circle that takes at least 2 minutes to complete. (Try to time your turn so that it takes 30 seconds or more to turn 90 degrees).

After completing one full circle, continue circling another time. Try slowing down even more and concentrate on keeping the boat steady and smooth throughout the 360°. Remember, the circles do not need to be perfectly round as long as you go a complete 360 degrees around.

4. Once you have completed two full circles, your compass should be compensated. Check to make sure by accessing the "**Compensation Display**" to review your auto-compensation and to check that everything is O.K. (*see below*)

Accessing the "Compensation Display" for Reviewing Compensation Data on the Sailcomp Remote.

The Sailcomp 103AC's "Compensation Display" allows you to critically examine the quality of a compensation, the quality of the sensor's location, how many auto-compensations have occurred, and lets you disable auto-compensation.

To see compensation data on the display:

1. Turn the power **ON** and wait until the display has gone through self-test.
2. Simultaneously push and hold down the **timer** and **crs(course)** **buttons** until the display reads "**CAL**".*

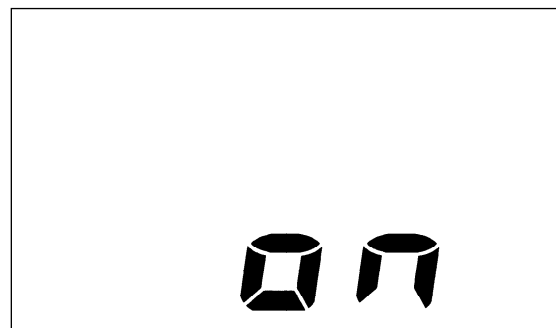

Once "**CAL**" is displayed, you may release the button. The display will now continuously roll through the following; "**on**" indicates that auto-compensation is enabled. ("**oFF**" indicates auto-compensation is disabled- *see page 22*).

**If desired, you may have the "Compensation Display" ON when doing compensation circles, so you can see when the compass has auto-compensated.*

"###" (three digits) are displaying auto-compensation data (a "000" indicates that the system has not been auto-compensated.)

- A. The **first digit** (1-9) indicates the **quality of the compensation** with "9" being the best.
- B. The **second digit** (1-9) indicates the **quality of the magnetic location** with "9" being the best.

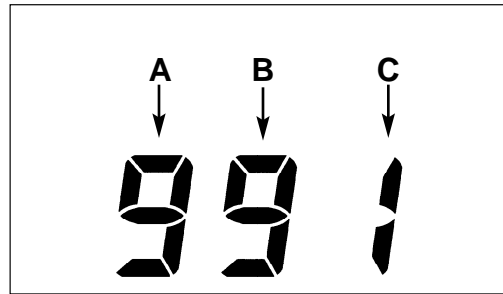

- C. The **third digit** is a **rollover counter** incrementing 1 digit each time the Sailcomp has accepted a new compensation.

For instance, if you got the above "991" it would indicate that you had a great compensation (9), a great magnetic location (9) and that this is your first compensation (1)*.

If the first digit is lower than a "7", you should turn another 360° to try and get a better compensation. If the second digit is lower than a "4", you may consider moving the sensor to a better magnetic location. However, even with a 3 or lower, as long as the first digit is a "9", you should have $\pm 1^\circ$ accuracy.

*Note: In rare cases, the magnetic field of a particular location may be so different from the factory calibration, that the sensor will re-compensate every 36° while doing a 360° turn. Do not be alarmed if the compensation display shows that more than one compensation has taken place or compensation takes place before you complete a circle. **Just make sure that you complete at least one full, slow circle.** Multiple compensations are an indication that the sensor is rapidly receiving better and better information and is updating its stored information for greater accuracy.*

If you ever significantly change your boat's latitude or make changes on your boat (install new equipment, run cables, etc.) which may affect the boat's magnetic field, or if you are ever in doubt as to the Sailcomp 103AC's accuracy, simply follow the auto-compensation procedure on pages 17-19 to be assured that it is accurate at all times.

To **exit** the "Compensation Display" apply two short pushes to the **crs** (course) **button** and the display will return to Compass Mode.

Alignment Error Adjustment

Now, you should check to see how well you aligned the sensor parallel with the centerline of your boat. To check the sensor's alignment, take a couple of known runs from a chart* and compare the magnetic bearing on the chart with the heading readout on the Sailcomp display. If the Sailcomp reading is off by the same amount of degrees in a couple of directions, then every reading around the compass will be off by exactly that amount. This indicates that the sensor is not pointing exactly forward in respect to the bow of your boat. Rather than rotating the sensor slightly to adjust for this Alignment ("A") error, you can adjust it electronically.

1. Enter into the "Compensation Display" as indicated on pages 19-20. To adjust for "A" error, apply a short push to the **cr** (course) **button**. The display will show "AoF", indicating that you have entered the "Alignment Offset" section of the software.

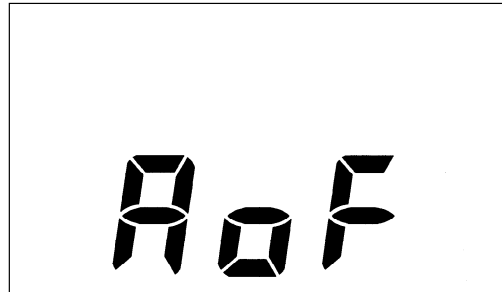

2. To examine the value for the "A" offset, apply a short push to the **nav button**. The display will flash the current value of the offset. Offset is set at the factory to 00°.
3. If the heading is "low" (or to the minus(-) side on all headings), you need to add offset. To increase the "A" offset, hold the **nav button** down until the desired plus(+) value is displayed.
4. If the heading is "high" (or to the plus (+) side on all headings), you need to subtract offset. To decrease the "A" offset, hold the **port button** down until the desired minus(-) value is displayed.
5. To change the offset, use the nav and **port buttons** to scroll up or down the correct number of degrees.
6. To save the "A" offset and return to compass mode, apply a short push to the **crs** (course) **button**. The new "A" offset will be stored in memory and the display will return to compass mode. Notice that the Sailcomp's headings will now match the known headings.

Note: Do not turn the 103AC's power OFF for at least 10 seconds after exiting the Alignment Offset Mode to allow the system to update and record the data in long term memory.

*The Sailcomp 103AC is more accurate than any compass you may have on your boat, so do not use another compass as a reference.

Example: After auto-compensation, a comparison of a couple of Sailcomp 103AC headings with "runs" from a chart indicate that the Sailcomp is reading 2° lower than it should be. For instance, instead of displaying 180° it is displaying 178°. This means that the sensor is pointing to the left of the boat's centerline by 2°. To correct this, enter into the "Compensation Display" by simultaneously pushing the **timer** and **crs** (course) **buttons** until "CAL" appears. Now enter the "Alignment Offset" section of the software by pushing and releasing the **crs** (course) **button**. Apply a short push to the **nav button** to examine the value entered for "A" Offset (from the factory, this will be "00"). You need to add 2° to all headings to adjust for the "A" error, so push and hold down the **nav button** until "02" appears on the display and then release the button. Exit by pushing the **crs** (course) **button** again. Now, when you point to your reference of 180°, the Sailcomp will display 180°.

Very Important! Once the Alignment Error is adjusted, it is stored in memory and never has to be re-adjusted unless the sensor is moved.

Disabling/Enabling Auto-Compensation

With auto-compensation disabled, your compass will be using the last compensation that has been stored, but will be unable to update itself if something changes in the boat's magnetic environment, etc. In essence, it is locked.

If you want to disable or enable auto-compensation, enter into the "Compensation Display" by simultaneously pressing the **timer** and **crs** (course) **buttons** until "CAL" appears. Release the buttons and "**on**" appears followed by **3 digits** (###). Hold down the **port button** and the display will toggle between "**oFF**" and "**on**". Release the button while "oFF" is displayed to disable auto-compensation.

Important Note: Be sure that **Damping Knob is in Position 1** while disabling or enabling auto-compensation.

Auto-compensation may be turned on/off in the Sailcomp 103AC whenever desired. Just be aware of what state it is in. You may check this at any time by entering into the "Compensation Display" and watching whether "**on**" or "**oFF**" is displayed.

To **exit** the "Compensation Display", apply two short pushes to the **crs** (course) **button**. Whatever was flashing on the display - "**on**" or "**oFF**" - will be activated and the display will return to compass mode.

II. SAILCOMP 103AC FEATURES

1. Sailcomp Features

The Sailcomp 103AC is very straightforward in its operation. The junction box controls **on/off**, the **damping** and the **light**. The remote keypad has five buttons which control the system's 5 modes: **Trend Mode**, **Off-Course Mode**, **Nav Repeater Mode**, **Head/Lift Mode** and **Starting Timer Mode**.

Port and Stbd: The **port** and **stbd** buttons are for the **Head/Lift Mode**. They are used to enter your port and starboard tack averages for racing.

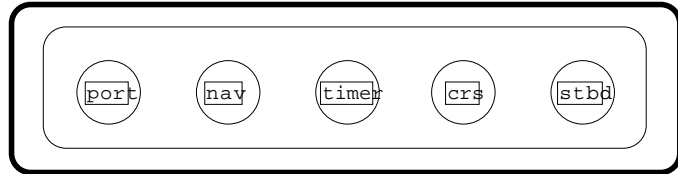

Nav: When connected to a NMEA 0183 navigation unit such as a loran or GPS, the nav button turns your Sailcomp 103AC into a loran or GPS repeater. Once connected to a loran or GPS, pushing the nav button makes the Sailcomp 103AC go into **Nav Repeater Mode**. The display will alternate every 2 seconds between Bearing to Waypoint and Distance to Waypoint in nautical miles. Cross Track Error is shown in .05 nm increments to port or starboard on the upper part of the display.

*Note: If the Sailcomp is not connected to a loran/GPS, if the loran/GPS is not ON, or if waypoints are not entered into the Loran/GPS, the Sailcomp 103AC display will display " - - - " when the **nav button** is pushed.*

Timer: The **timer button** puts the system into **Starting Timer Mode** and displays the time remaining until the start of a race.

Crs (Course): The **crs button** serves two main functions. It sets the course that you want to use as a reference for the off-course indicator and it also allows you to change between **Trend Mode** and **Off-Course Mode**.

2. Damping Control

The **damping knob** on the junction box controls the averaging period over which the compass displays information. Damping does not diminish the accuracy of the Sailcomp 103AC like it does in a conventional compass. The damping levels range from 1-4, with damping 1 a nearly instantaneous readout and damping 4 about 14 seconds of averaging. On most boats, damping 2 or 3 is the most stable and responsive. If you are in rough seas, you may want to increase the damping so that you get a more stable display. In calm water or at lower speeds, you may want to decrease the damping so that the display responds more quickly.

III. SAILCOMP 103AC MODES

The Sailcomp 103AC's 5 modes: **Trend Mode**, **Off-Course Mode**, **Nav Repeater Mode**, **Head/Lift Mode** and **Starting Timer Mode** are all explained in detail on the following pages.

1. Trend Mode

Every time the compass is turned ON, it automatically goes into **Trend Mode**. "Trend" refers to the rate of turn. The purpose of the trend indicator is to help keep you oriented in terms of how fast you are turning to the left or to the right -- something that can be difficult to perceive with a digital readout alone.

2. Off-Course Mode

Trend Mode only shows your rate of turn. It does not show you how far off-course you are. To do that, you need to enter a reference course (so the Sailcomp knows where you want to go). You can enter a reference course only when you are in the Off-Course Mode. In the Off-Course Mode, your present heading is compared to a reference heading that you have selected and the difference is displayed in degrees with segments to the left or right on the upper analog display. The Off-Course Mode is very useful for sailing long or short distances as it enables you to set a rhumb line and then sail to the upper analog display, steering to left or right to keep the segments zeroed out.

To use the Off-Course Mode:

1. Turn the Sailcomp **ON**. You are now in Trend Mode.
2. The **first push** on the **crs** (course) **button** puts you into Off-Course Mode. The word "**Crs**" appears where the digits normally are, to tell you that you are now in Off-Course Mode. The Sailcomp will use whatever heading was previously stored as the reference heading. (The default setting is "000°" and resets to this every time the unit is turned off).

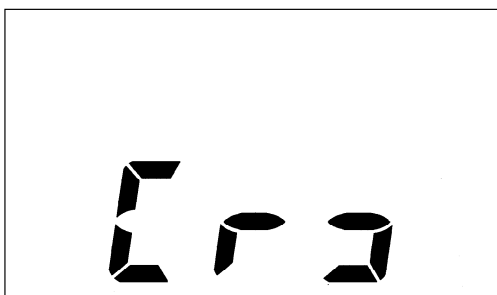

1 port and 1 stbd segment appear on each side of upper (analog) display.

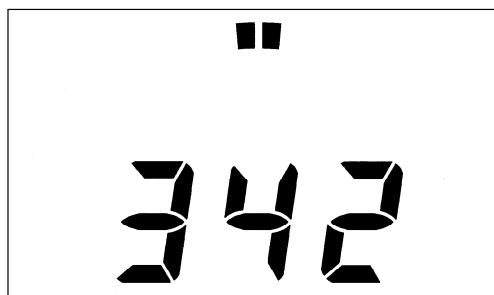

Display freezes on selected heading.
Set Course = 342°

- Point your boat in the direction you want to go, steering to the digital heading for your desired course. When the desired course appears on the display, push the **crs** (course) **button** again. The upper display will show a single segment on either side of center to indicate that this is now the reference heading. The digits momentarily freeze on the new heading while you hold the button down. This will now be the reference course stored in the Sailcomp's memory (*see illustration on facing page*). **Do not hold the button down for more than two seconds or the system will return to Trend Mode.**

In Off-Course Mode, the digital display continues to display the current compass heading, while the upper analog display graphically shows how far off course the current heading is to your reference course. When you steer off of the reference course, you will see segments to the left and right on the upper part of the display corresponding to how many degrees to port or starboard you are off your reference course's rhumb line. By centering the upper display so that there are no segments to the left or right, you will be steering to your reference course. (*see following illustrations*)

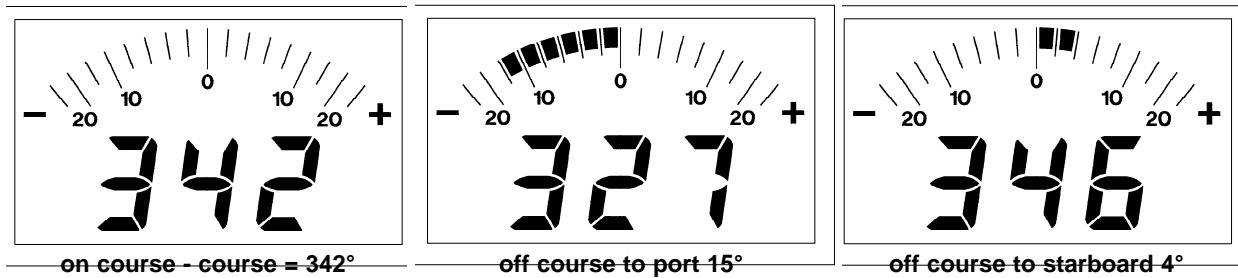

- If you want to enter a new heading, just press the **crs** **button** again. Once you are in the Off-Course Mode, each subsequent push will enter the compass' current heading as the reference course. The upper display will instantly lock into this new set course.

Note: Every time you turn OFF the Sailcomp 103AC, it will reset to a default reference course setting of 000°.

Getting Back to Trend Mode

Once you are in Off-Course Mode, each time you push the **crs** **button**, a new reference heading is entered. However, if you hold the button down for two seconds or more, the compass will go back into Trend Mode. The word "Trd" appears where the digits normally are, to tell you that you are now in Trend Mode.

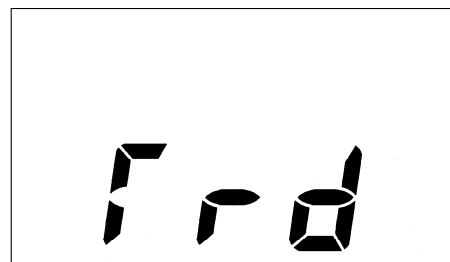

3. Nav Repeater Mode

If you have connected your Sailcomp 103AC to a NMEA 0183 Loran or GPS, you can access navigational information by pressing the **nav button**.

As long as both the Sailcomp 103AC and the loran/GPS are powered up, each time you push the **nav button**, the display will show loran/GPS information. The Nav Repeater Mode provides steering information only, so if your loran or GPS is giving position information, you will not get any steering information on your Sailcomp 103AC display. In this case, when you push the **nav button**, the display will read "- - -" to remind you that you have not entered any waypoints into your loran or GPS. Also, if for any reason your loran or GPS is switched off at its box, the Sailcomp's Nav Display will revert to "- - -" to warn you that it is not receiving any information from the loran or GPS.

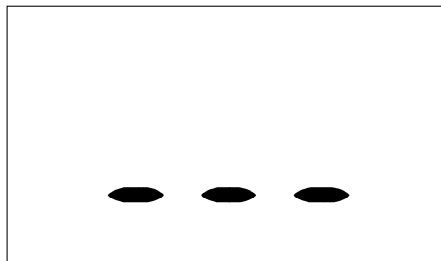

When you instruct your loran or GPS to steer you to a waypoint, the Nav Display will be activated. Every 2 seconds the repeater will alternate between displaying "**Bearing to Waypoint**" and "**Distance to Waypoint**".*

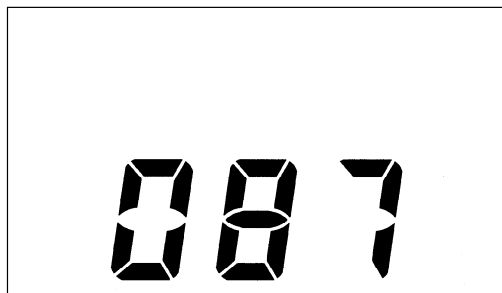

Bearing to Waypoint

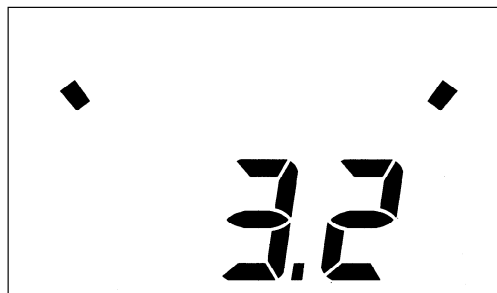

Distance to Waypoint
(nautical miles)

As you progress, if you get any cross track error, the upper part of the Sailcomp display will show you cross track error to port or starboard with segments in increments of **.05 nautical miles** while Distance to Waypoint is displayed. When there are no segments on the upper display, this means that you are on the rhumb line to your waypoint.

Once you are in the Nav Repeater Mode, pushing any other button will exit the Nav Repeater Mode and put you into the pressed button's Mode.

**If "snr" or "oor" is displayed, this is an indication that the loran/GPS is not outputting valid information. See pg. 67 for descriptions of these messages.*

Here are some examples of what you will see on your Sailcomp 103AC display when you have connected the system to a NMEA 0183 Loran or GPS and are in Nav Repeater Mode.

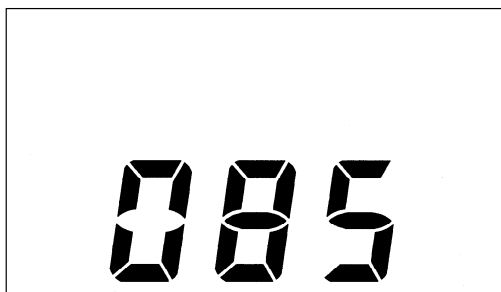

Bearing to Waypoint = 085°

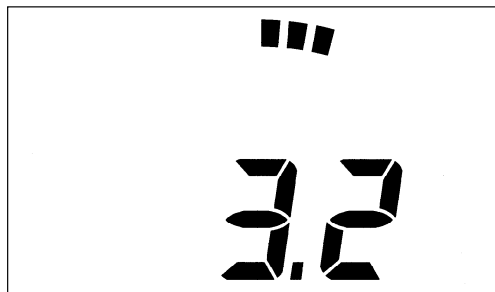

Distance to Waypoint = 3.2 nm
.15 nm cross track error to right of track



Bearing to Waypoint = 089°

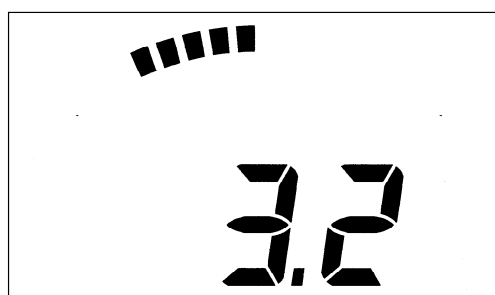

Distance to Waypoint = 3.2 nm.
.25 nm cross track error to left of track

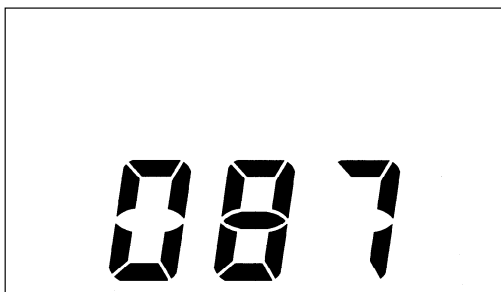

Bearing to Waypoint = 087°

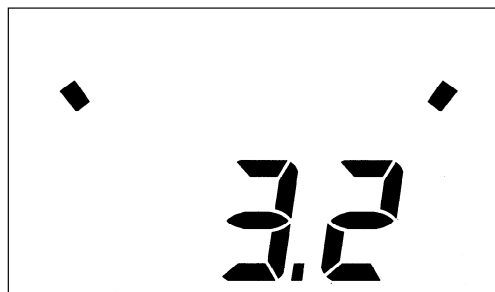

Distance to Waypoint = 3.2 nm.
no cross track error

4. Head/Lift Mode

The Head/Lift Mode operates in a manner quite similar to the Off-Course Mode except that it handles two reference headings simultaneously and the computer determines which of these to use.

To use the Head/Lift Mode, do the following:

1. Push either the **port** or **stbd** button. This first push puts you into the **Head/Lift Mode**, but does not alter anything.
2. Before the start of a race, sail upwind on port tack for at least 10 minutes and observe your compass reading. Determine what your average heading is over this period. This heading becomes your **Port Tack Average**.

Sail on this heading and push the **port button** to store this heading as your port tack average. Make sure the digital heading on the display is reading what you consider to be your port tack average when you push the button.

Repeat the same procedure on starboard tack, and push the **stbd button** to store your **Starboard Tack Average**.

When racing upwind on **port** or **starboard tack**, if you are sailing closer to the mark than the stored averages, more upwind, this is called a **Lift**. If you are heading farther away from the mark than the averages (more downwind), this is called a **header**.

These averages will be stored in memory, and if you are in the Head/Lift Mode, the Sailcomp will know which tack you are on and will calculate whether you are being headed or lifted and by how much. This information is sent graphically to the upper analog section of the remote display. The words, "HEAD" or "LIFT" will also be displayed on the upper part of the display. *(This is a quick way to determine whether you are in Head/Lift Mode or Off-Course Mode.)*

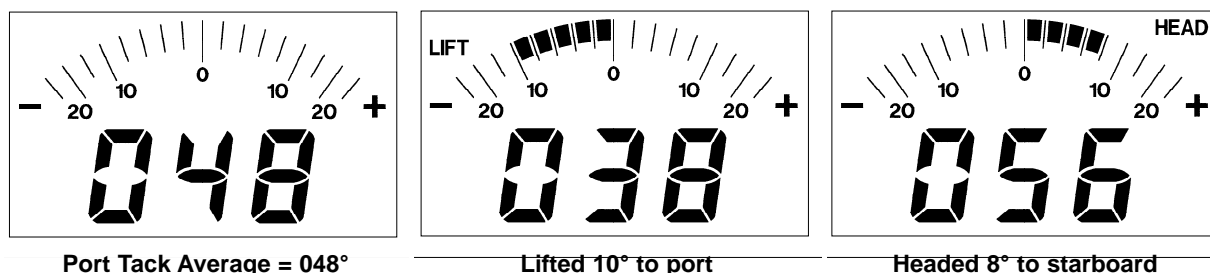

Remember that everything you see on the upper bar graph on the remote display is perceptually normal in terms of left and right. If you see segments to the right when you are in any mode it means the same thing: you are heading to the right of your ref-

erence course or average. When in the Head/Lift Mode, the segments will point in the direction you are heading relative to the average. For example, if you are on port tack and are being lifted, the segments will fill to the left on the display, indicating that you are heading more to the left than your port tack average. Note that the segments are also pointing upwind, reminding you that this is a lift on starboard tack. The word "LIFT" will also be displayed on the upper left hand corner of the remote display.

Important: In Head/Lift Mode you do not select which course to use, the computer does. It "thinks" you are on port tack if you are closer to the port tack average than the starboard tack average. Each time you tack, the compass automatically switches to the proper reference heading for that tack. The principal advantage of this feature is that you don't have to touch the compass after the start of the race (unless the averages change). However, two things you should keep in mind: if you mistakenly enter the port tack average into the starboard tack memory slot, the head/lift information will be backwards. This is because higher numbers are headers on port and lifts on starboard. The computer knows this, so you have to keep the two straight. The other thing you should keep in mind is that if you get a permanent wind shift of more than 45 degrees, you have to enter new averages, because then you could be closer to the port tack average and still be on starboard tack. The latter is usually not a problem since such a drastic windshift occurs rarely, and when it does, you have to recompute your averages anyway.

5. Starting Timer Mode

The Timer feature works in the same manner as the other buttons.

To use the Starting Timer:

1. Press the **timer button** at the 10 minute gun. If the timer is not already running, the first push will start it at 10 minutes "0.00". The timer will begin counting down in seconds immediately. The countdown will appear on the Sailcomp display as large digits and the upper display will disappear.



First press on timer button starts 10 minute countdown

2. Once the timer is running and counting down on the Sailcomp display, subsequent pushes on the timer button will reset the timer to a 5 minute countdown.

**If the timer was already activated and then you exited the timer mode to enter another mode, the next push on the yellow button will put you back into timer mode and show you the time remaining on the timer from the initial push, but will not reset the timer.*

3. To switch out of Timer Mode to view any other mode's information, press that mode's button. The timer will keep track of the remaining time so that when you press the **timer button** again to re-enter the Timer Mode, the display will show the time remaining.

4. During the last 8 seconds, the display automatically switches to the Timer Mode and gives a graphic countdown to the start (*see illustration, right*). After the gun, the display automatically switches back to compass heading. If you are in a multiple fleet starting sequence, just catch one gun. When the timer runs out, it automatically rolls over onto another 5 minute sequence so that you will always be synchronized with the Race Committee.

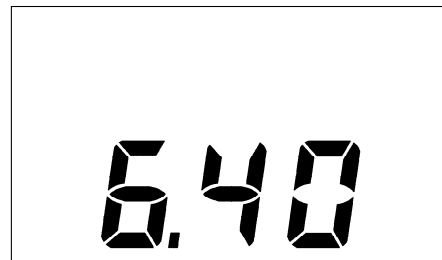

6 minutes, 40 seconds
until starting gun

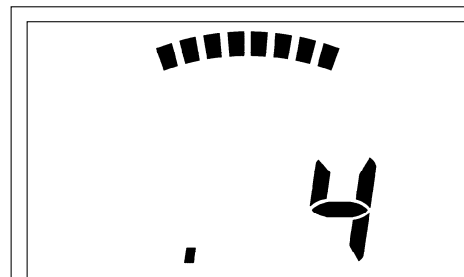

4 seconds until starting gun

Note: The 8 second graphic countdown only appears for 10 minute countdown periods and will not reappear for subsequent 5 minute sequences.

5. If you want to reset the timer to a 10 minute countdown, **hold down the timer button and press the port button**. Make sure that you keep the timer button depressed while you press the port button. The timer will reset to "0.00" and will immediately start another 10 minute countdown.

6. Switching between Modes

The Sailcomp 103AC's 5 button system allows you to easily access, enter, and see each mode's data on the display. **To enter into a mode without changing the stored data, push on the desired mode's button once.** This will put you into the mode and allow you to review the mode's data on the display without changing the data. This method allows you to change modes while saving information; for example, to keep your port and starboard averages stored while you are using the Off-Course Mode and vice versa. Remember, a single push on the nav, timer, crs, port or starboard button brings you back into the particular mode without erasing or re-entering information.

The **second push on any button (but the nav button) will alter the data stored by the system.**

When in Off Course Mode, the second push (and each subsequent push while the mode is being displayed) stores the present heading in memory and uses it as the new reference course.

When in Head/Lift Mode, the second push (and each subsequent push while the mode is being displayed) stores the present heading in memory and uses it as the new average heading.

In Starting Timer Mode the second push (and each subsequent push while the mode is being displayed) resets the timer to 5 minutes.

In Nav Repeater Mode, a second push on the nav button will not affect anything because when the system is in Nav Repeater Mode it is merely acting as a repeater for your loran or GPS device.

This principal also works every time you turn the compass on. Each time the compass is switched on, it has reset all references to 000° by default. So if you push any button only once (except the nav button which is getting information from your loran or GPS), it will assume that you want to use the last reference heading which is the default of 000°. You can see that the Sailcomp is being perfectly consistent, so you should get into the habit of **pressing once to get into the mode before you are ready to enter the information, and pressing it again when you are ready and sailing on your desired course for the particular mode.**

If you have any doubt as to whether you are in a particular mode and want to immediately enter information, **press the button twice.** It does no harm to enter the same number twice.

IV. RACING WITH THE SAILCOMP

The uses for the Sailcomp's many features during a race are listed below in order of how you would use them in a race.

1. Shooting the Wind

You can use the **Off-Course Mode** to shoot the wind before a race. While the boat is head to wind, you can push the crs button when in Off-Course Mode so that the Sailcomp will remember the bearing for you. This way, the next time you shoot the wind, it will show you graphically if the wind has gone left or right. If you are in a small, light boat, you may want to reduce the damping on the compass to position #1 so that the display will give you fast information. This ensures that you will be able to take a quick accurate reading before your boat goes into irons.

2. The Starting Line

You can use the accuracy of the digital compass to precisely determine which end of the line is favored and exploit this to your advantage. By carefully sighting the wind and then the starting line, even a 2 or 3 degree favor can be detected. The mechanics of this operation are quite simple. First, point your boat into the wind and remember the heading. Next, run the starting line from one end to the other and again note your compass heading. Now, subtract the two numbers. If the line is perfectly square, the difference should be 90 degrees. If it's more than 90 you were heading away from the favored end. If it is less than 90, you were heading toward the favored end. To most sailors, this is nothing new. True enough, but having the exact number on a digital readout makes it easier to do the math and more accurate than some of the other methods now in vogue. Detecting a 3 degree favor may not seem that important, but if the starting line is 1000 feet long (typical for a 30-40 boat fleet), then you would be starting 72 feet ahead of someone at the other end. Those 2 or 3 boat lengths will mean the difference between clean and dirty air for the first part of the beat.

3. The Start

Obviously, being at the starting line when the gun goes off is your goal. By using the **Starting Timer Mode**, both crew and skipper can see how much time is left by a mere glance at the display. And if you need to see the compass heading or any other data within the 10 minute pre-race time, press the desired mode's button to access this mode's data. When you press the timer button again, the countdown will reappear with the time remaining on the display.

The graphic display of the last 8 seconds-until-start has been designed to catch the frantic crew's attention with a graphic countdown on the upper bar graph display.

After the start, the compass heading immediately returns so that you are never without your compass heading in the race. The timer continues to countdown in the background, resetting to 5 minute countdowns continuously so that you are always synchronized with the Race Committee in case there is a general recall.

4. The First Upwind Leg

There are two primary functions of the Sailcomp compass sailing upwind. One is to provide you with more accurate numbers and the other is to graphically keep track of the course changes due to windshifts.

To recap, in order, the uses of the **Head/Lift Mode**:

Sail upwind on each tack for at least 10 minutes (ideally this is done before the start). Sailing upwind, you should use this time to put your boat in the groove and get your sails adjusted to the wind and water conditions. Once you feel comfortable with your settings, start looking at the compass. Note the high and low numbers on each tack. Now press the port or stbd button to get into Head/Lift Mode. When you feel you are on the median heading for port tack, press the port button.

Once in Head/Lift Mode, pressing the port button locks your present heading into memory and tells the compass, "Remember this number, this is my port tack average heading". Then repeat the procedure on starboard and press the stbd button to lock in your starboard average. Now the Sailcomp has both your averages "in mind" and can show you visually on the upper analog display when you are being headed or lifted.

If you are sailing on port and see five segments to the right of center, this means you are ten degrees to the right of your average. On port tack, going to the right of your average is a header, so the compass will also display the word "HEAD" on the upper display.

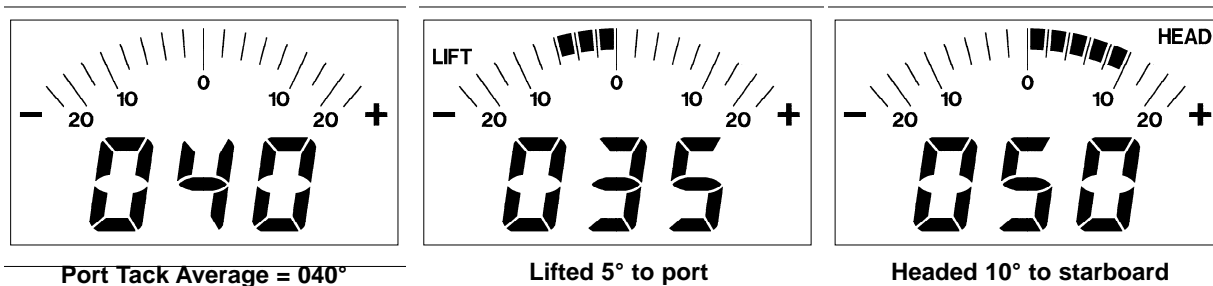

The compass knows that going right may be a header on port tack, but going right is a lift on starboard tack. When this happens, the word "LIFT" will show up on the display.

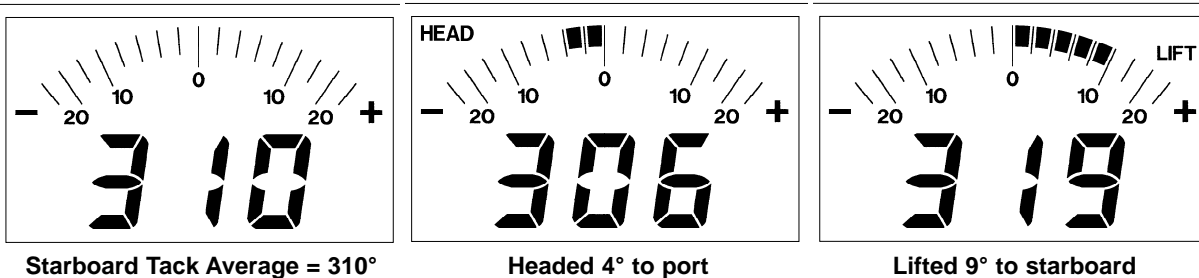

During the race, as you sail upwind, you do not need to press the buttons again until you feel your averages have changed. In other words, you don't need to push a button every time you tack. The compass just assumes that if your port tack average is 040° and your starboard average is 310° and you are now heading 050°, you must be on port tack. It looks at your averages and assumes that you are on whatever tack has an average closest to your present heading. This system works fine until you get a 45+° permanent windshift. When this happens, it is time to start pushing buttons to reset your port and starboard tack averages.

The upper analog portion of the display is intended to show you visually both how far and in which direction your boat has turned since punching in the averages. If you are continually seeing more and more segments on the left side of the display, you may decide that you are into a persistent left shift pattern. Similarly, if the number of segments seem to be about the same on lifts and headers, then you might conclude that it is a simple oscillating shift pattern. We just provide you with the information (the easy part), we leave the rest up to you!

Beware the velocity shift.

Since the Sailcomp works independently of any actual wind data, you have to be careful in the case of a velocity shift. This is not really a shift in the true wind direction, but is only a shift in the apparent wind direction caused by a sudden gust or lull. The best way to avoid being fooled by a velocity shift is to wait at least 10 seconds before tacking on what you think is a real shift. This allows your boat to speed up or slow down to the speed at which it should be going for the new wind. Remember that velocity shifts are caused by significant changes in the wind velocity, so pay attention to the amount of wind hitting you in the face! Most tactical experts would advise waiting anyway, since tacking too soon may cause you to sail right back out of the windshift you were intending to take advantage of.

5. The Downwind Leg

While sailing dead downwind, it is often difficult to determine when the wind has shifted and in which direction. Unlike upwind, most people do not pay attention to compass numbers while going downwind. To further complicate things, most people don't sail dead downwind anyway, they usually keep around 30 degrees off the apparent wind in order to keep their boatspeed up and increase their VMG toward the mark. To help keep track of which jibe to be on, one of our customers suggests the following:

Push the crs button to get into **Off-Course Mode**. Now point your boat at the leeward mark (or the rhumb line if you can't see the mark), and press the crs button again to lock onto that number. Now just go back to sailing as you normally do and keep the windex at 30° off the apparent wind. The objective is to keep pointed close to the mark and still keep your boat speed up by staying at 30 apparent. You as helmsman do your part and keep an eye on the wind, the tactician should watch the Sailcomp display. If you start veering off too far, he will begin to see more and more segments on the upper part of the display. When this happens, and you are still on the wind angle you want, it means that there has been a windshift. You now are heading farther away from the mark just to keep the same wind angle that you had before. All other things being equal (like wind speed and boat speed), you should jibe now so that you will be pointed more at the mark and still be able to maintain your nice 30 degree apparent wind angle.

To put it simply, keep your boat pointed at the mark by jibing so as to minimize the number of segments on the off-course indicator.

6. The Second Upwind Leg

When you get to the bottom mark, you will want to get back into the **Head/Lift Mode**. As soon as you round the leeward mark and start sailing upwind, there is usually enough going on so that it is difficult to remember what your averages were on the last beat. Yet this is precisely the critical moment when you need to know whether or not to tack - to get into phase for the next beat. To solve this problem, just push either the port or stbd button once. This tells the Sailcomp that you are now going up-wind again and want to know if you are being headed or lifted. Both the starboard and port tack averages are then recalled from memory and you are back in business.

If after a while, you feel that you want to reset the averages, steer to the desired compass heading and push the appropriate button. Once the display is in Head/Lift Mode, each subsequent push to either the port or stbd button will reset the averages.

V. SPECIAL FUNCTIONS

1. True North Capability

You may enter the magnetic variation of your boat's location into the Sailcomp 103AC's memory so that it displays True North rather than Magnetic North. As you know, when you go from Magnetic North to True North, you add Easterly deviations and subtract Westerly deviations. (From True to Magnetic - do the opposite). Therefore, if you have a magnetic variation of 14°W, you will subtract 14° from all headings to display True North. Magnetic variation is entered into the system by using the "A" Offset capability accessed through the "Compensation Display".

Entering Magnetic Variation

To enter magnetic variation into the Sailcomp 103AC's memory, enter into the "Compensation Display" by **simultaneously** pushing the **timer** and **crs(course)** buttons until you see "CAL" appear on the display. Then apply a short push to the **crs** button. The display will show "AoF", indicating that you have entered into the "Alignment Offset" ("A" Offset) section of the software.

1. To examine the value for the "A" Offset, apply a short push to the **nav** button. The display will flash the current value of the offset. Offset is set at the factory to 00°. **Important Note:** If you added or subtracted "A" Offset error during your initial compensation, then you will need to add the magnetic variation to the "A" Offset value and enter the sum. For instance, if you entered -2° for "A" Offset and at your location there is a magnetic variation of 14°W then the equation is: $(-2^\circ) + (-14^\circ) = (-16^\circ)$ You will enter -16° into the Memory.
2. To enter positive (+) values for magnetic variation, hold down the **nav** button until the desired (+) value is shown on the display.
3. To enter negative (-) values for magnetic variation, hold down the **port** button until the desired (-) value is shown on the display.
4. To change the offset, use the **nav** and **port** buttons to scroll up or down the correct number of degrees.
5. To save the variation value and return to compass mode, apply a short push to the **crs** button. The new value will be stored and the display will return to compass mode. You will notice that the Sailcomp's headings will now read True North. Make sure you record this information at the back of this manual (pg. 46) for future reference.

2. Warning Messages

"Er1" Message

If the Sailcomp display flashes "Er1" alternately with normal compass information, this indicates that the sensor is "magnetically overloaded". If this message is displayed when installing your Sailcomp 103AC, the compass cannot perform auto-compensation and must be moved to a better location where you do not get this message. If this message suddenly appears long after you have installed and compensated your compass, it is an indication that something has dramatically changed in the sensor's environment. Check the area around the sensor. This message can be caused by a magnetic field or large amounts of metal located near the sensor. Speakers, tool boxes, anchors, and electric motors are items that could cause this message to appear.

"Lo" and "bAt" Message

If the display alternately flashes "Lo" and "bAt", the unit has insufficient voltage to function reliably. All functions and auto-compensation will be prohibited until the Sailcomp 103AC receives sufficient power/voltage to function. You should immediately remedy the situation when you see "Lo" "bAt" displayed.

"snr" Message

"snr" stands for "signal to noise ratio". If the "snr" bit is set in the loran's or GPS' "APA" or "XTE" NMEA 0183 sentences, the Sailcomp display will indicate this by displaying "snr" as shown, right. "Miles to Go" and "Bearing to Waypoint" will not be displayed until this bit is cleared.

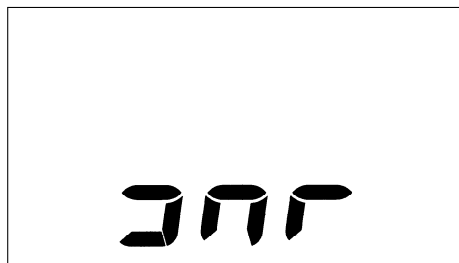

"oor" Message

"oor" stands for "out of range". The Sailcomp will display "oor" if the loran's or GPS' distance field in the "BWC" or the "WDC" NMEA 0183 sentence is a null field or is greater than 999.9. "Miles to Go" will not be displayed until the distance field is less than 1000. The Sailcomp display will alternate between "Bearing to Way-point" and the "oor" message.



VI. APPENDIX

1. Technical Specifications

Performance

Accuracy	±0.5° (to 30° heel)
Temp. Range (sensor)	.0°C to 70°C
(display)	-10° to +90°C
Humidity Range	.0% - 100%
Field Strength Sensitivity	.6.5 - 65μ Tesla
Range Horiz. Component	.80° Mag. Incl. or dip
No. of Repeaters	.4 maximum
Damping Levels	.Select Range 1-4

Interface Capability

Loran/GPS Input	.NMEA 0183
Standard Output	.NMEA 0183
Other optional interfaces available	

Power Supply

Voltage Requirements	.12V DC
Current Consumption	.65 mA light off
	.97 mA light on

Dimensions

Remote Sensor	.4.8" D. x 5" H
Display Unit	.4.8" x 3.6" x 0.8"
Junction Box	.6.3" x 2.9" x 2.2"
Remote Keypad	.4.8" x 1.8" x 0.9"

Weight (with cables)

Remote Sensor	.2 lbs
Display Unit	.14 oz.
Junction Box	.15 oz.
Remote Keypad	.10 oz.
Shipping Weight	.7 lbs.

2. Troubleshooting

Any problem you may have with the Sailcomp 103AC can usually be quickly remedied by first checking for the following:

1. low battery voltage
2. incorrect installation
3. poor electrical connections
4. dirty connector plugs or receptacles

Nevertheless, a troubleshooting guide follows:

Backlight out

Segments dim or missing from LCD

1. Check power supply as battery voltage may be incorrect or so low that even "Lo" "bAt" cannot be displayed.
2. Check cables and connectors making sure they are properly connected. Sockets or pins in connector plugs or junction box receptacles may be dirty. To clean: use a soft bristled brush and a contact cleaner (Radio Shack, etc). Take care not to use any hard object that could bend the connector pins.
3. Call the KVH Sales Office.

Random segments appear

All segments come on at once and freeze

Heading Freezes

No reading on display

Heading resets to 000°

1. Check power supply as battery voltage may be incorrect or so low that even "Lo" "bAt" cannot be displayed.
2. Check cables and connectors making sure they are properly connected. Sockets or pins in connector plugs or junction box receptacles may be dirty. To clean: use a soft bristled brush and a contact cleaner (Radio Shack, etc). Take care not to use any hard object that could bend the connector pins.
3. There may be an electrical noise source too near sensor. Install an in-line noise filter. Recommended: Radio Shack 270-051
4. Call the KVH Sales Office.

During an intentional auto-compensation:

A. "compensation display" shows a compensation has occurred before turning 360°;

Most likely, you were turning in a circle, before you "started", that is, before you noted the heading on the display*. Continue turning in a slow, full circle. Most likely, the display will record another compensation (unless the compensation was not 25% better than the first one).

B. "compensation display" shows a compensation occurring approximately every 36° during a 360° turn;

On some boats, the particular magnetic field is so dramatically different from what the compass has stored from its factory calibration or from a previous compensation that the compass will take new information every 36° to quickly try and improve its accuracy. If this happens after you have initially compensated your compass, it is an indication that the environment has dramatically changed around your Sailcomp sensor. For instance, someone may have stored an anchor near the sensor. If you are not aware of any changes, you should check the sensor's environment, do an intentional auto-compensation (see pgs. 17-19) and examine the compensation data (pgs. 19-20).

C. "compensation display" shows multiple compensations have occurred after completing a full circle.

This is normal. Unit can recompensate often and will if it receives better information.

After several attempts at an intentional Auto-Compensation, the "Compensation Display" does not show that an Auto-Compensation has occurred and the heading accuracy has not improved.

1. You are probably turning too fast. Make sure you are not traveling faster than 90° in 30 seconds. **GO SLOWLY!**
2. Conditions may be too rough. The boat's pitch and roll is affecting the sensor.
3. Check the "Compensation Display" to see if the sensor has accepted a compensation (pgs. 31-34) and if Auto-Compensation is disabled (pgs. 19-20).
4. Magnetic location may be unstable. Move the sensor away from changing magnetic fields (see pgs 7-9).

When Nav Button is pushed, " - - -" appears on the display.

1. The Sailcomp 103AC has not been connected to a NMEA 0183 loran or GPS.
2. The Loran or GPS that the Sailcomp 103AC is connected with is not turned on. If it is ON, check the wiring between the loran/GPS and Sailcomp 103AC.
3. No waypoints have been entered into the loran or GPS, or the loran/GPS has not been instructed to steer to a waypoint. Lorans all differ in how they are programmed. Make sure you have properly entered waypoints into the loran or GPS and programmed the loran to steer to waypoints. (see "*Nav Repeater Mode*", pgs. 26-27).

Heading inaccurate

Heading jumps erratically or too slowly

Heading jumps randomly; unstable

Heading freezes

1. Check power supply as battery voltage may be incorrect or so low that even "Lo" "bAt" cannot be displayed.
2. Check cables and connectors making sure they are properly connected. Sockets or pins in connector plugs or junction box receptacles may be dirty. To clean: use a soft bristled brush and a contact cleaner (Radio Shack, etc). Take care not to use any hard object that could bend the connector pins.
3. Check the damping level to make sure it is set correctly for your boat size and/or boating conditions.
4. Check installation of sensor. Sensor may not be mounted upright; See sensor installation instructions (pgs. 7-9).
5. First check the Compensation Display's "location score", (pgs. 19-20). If the second digit is lower than a "4", try moving the sensor and doing an intentional auto-compensation (pgs. 17-19).
6. If the "location score" is O.K., check location of sensor. Sensor's environment may have been changed by newly introduced ferrous metal or a new and/or changing magnetic influence and auto-compensation is trying to recompensate for these influences. The sensor cannot compensate for rapidly changing fields like a nearby motor turning on and off. If the environment looks unchanged, try doing auto-compensation circles (see pgs. 17-19) to see if the sensor takes a new compensation

and settles down.

7. Call the KVH Sales Office.

Keypad Buttons don't operate

1. Check that the cable is connected to the junction box.
2. Check cable and connector making sure they are properly connected. Sockets or pins in connector plug or junction box receptacle may be dirty. To clean: use a soft bristled brush and a contact cleaner (Radio Shack, etc). Take care not to use any hard object that could bend the connector pins.
5. Call the KVH factory.

Power switch does not operate

Light switch does not operate

Damping switch does not operate

1. Check power supply as battery voltage may be too low. If so, charge battery.
2. Check electrical connections making sure connections are all o.k.
3. Check cables and connectors making sure they are properly connected. Sockets or pins in connector plugs or junction box receptacles may be dirty. To clean: use a soft bristled brush and a contact cleaner (Radio Shack, etc). Take care not to use any hard object that could bend the connector pins.
4. Call the KVH factory.

3. Wiring Data

Cable from Sensor to Junction Box

<u>Function</u>	<u>Color</u>	<u>Conn. Pin No.</u>
+12V	Brown	1
Ground	Red	2
+5V	Orange	3
Clock	Yellow	4
Load	Green	5
Data	Blue	6
Damping 0	Purple	7
Damping 1	Gray	8
Port Trigger	White	9
Stbd. Trigger	Black	10
Spare	Tan	11
Timer Trigger	Pink	12

Remote Keypad to Junction Box

<u>Function</u>	<u>Color</u>	<u>Conn. Pin No.</u>
Off-Course	Red	1
Ground	Black	2
Nav	Blue	3
Port Trigger	Brown	4
Stbd Trigger	Green	5
Timer Trigger	White	6
Ground	Shield	7

Remote Display to Junction Box

<u>Function</u>	<u>Color</u>	<u>Conn. Pin No.</u>
+5V	Red	1
Light Return	Black	2
Clock	Blue	3
Load	Brown	4
Data	Green	5
Light +	White	6
Ground	Shield	7

NMEA 0183 Cable Wiring

<u>Function</u>	<u>Color</u>
NMEA (+) Out	Green
NMEA (-) Out	Orange
NMEA (+) In	Blue
NMEA (-) In	Brown
Spare	Red
Spare	White
Spare	Black
Spare	Shield

4. NMEA 0183 Interface Output

The NMEA interface transmits heading data organized into sentences defined as follows:

- Sentence length is 19 bytes.
- Update Rate =10 Hz.
- Format parameters:
 - * Bytes are encoded as 7 bit ASCII characters in an 8 bit byte with the most significant bit set to zero.
 - * No Parity bit.
 - * One start bit & one stop bit.
 - * 4800 Baud
 - * The total number of bits per transmitted data byte is 10.

The sentence is: \$HCHDM,abc.d,M*<checksumMS><checksumLS><cr><lf> where a is the BCD hundreds digit of the heading, b is the tens digit, c is the ones digit, and d is the tenths digit. <checksumMS> is an ASCII character in the range 0-9 or A-F that represents the most significant nibble of the checksum. Similarly, <checksumLS> represents the least significant nibble of the checksum.

The checksum is calculated by XOR'ing together all the characters in the sentence up to, but not including the "*" character. [i.e. XOR together "H", "C", "H", "D", "M", "(comma)", "hundreds digit", "tens digit", "ones digit", "decimal point", "tenths digit", "(comma)", "M"]

5. Nav Repeater NMEA 0183 Input

Composite Sentences

APA: cross track error

Number	1	2	3	4	5	6	7	8	9	10																						
Format	\$	L	C	A	P	A	,	A	,	X	.	X	X	,	L	,	N	,	A	,	A	,	X	X	X	.	M	,	C	C	C	C

1. OR'ed Blink and SNR; 2. Cycle Lock; 3. - 4. - 5. Cross Track, Sense L or R, N. Mi. Units; 6.- 7. Arrival circle, Arrival Perpendicular (crossing of the line which is perpendicular to the course line and which passes through the Dest. WPT.); ; 8.- 9. Bearing Dest. Wpt. from Origin Wpt., Magnetic; 10. Dest. Wpt. Identifier. For Blink, SNR and Cycle Lock, A=Valid, V=Invalid. For Cross Track Sense, L=Steer Left, R=Steer Right.

BWC: bearing to destination and great circle distance to waypoint from the current point

Number 1 2 3 4
 Format \$LCBWC,XXXXXX,XXXX.XX,N,XXXXX.XX,

Number 5 6 7 8 9 10 11 12
 Format W, XXX.,T,XXX.,M,XXX.X,N,CCCC

1. UTC of Bearing; 2.- 3. Lat,N or S of Wpt; 4.- 5. Long. E or W of Wpt; 6.- 7. Brng., True;
 8.- 9. Brng., Mag.; 10.- 11. Dist., N.Mi; 12. Wpt. Ident.

Primitive Sentences**XTE: cross track error**

Number 1 2 3 4 5
 Format \$LCXTE,A,A,X.XX,L,N

1. Or'ed value Blink and SNR (A=Valid, V=Invalid); 2. Cycle Lock, (A=Valid, V=Invalid); 3.- 4.- 5. Cross Track Error; 4. Steer Left or Right (L=Left, R= Right); 5. Units (N.Mi.)

The following sentences used only if **BWC** is not used:

BOD: bearing to destination from the original point

Number 1 2 3 4 5 6
 Format \$LCBOD,XXX.,T,XXX.,M,CCCC,CCCC

1.- 2. Brng. True; 3.- 4. Brng. Mag; 5. Dest. Wpt. Identifier; 6. Origin Wpt. Identifier

WDC: great circle distance to waypoint from the original point

Number 1 2 3
 Format \$LCWDC,XXX.X,N,CCCC

1.- 2. Dist., N.Mi.; 3. Wpt. Ident.

7. Warranty & Protection Plan

LIMITED WARRANTY ON HARDWARE

KVH Industries, Inc. warrants the Sailcomp 103AC purchased against defects in materials and workmanship for a period of ONE (1) year from the date of original retail purchase by the original purchaser. If you discover a defect, KVH will, at its option, repair, replace or refund the purchase price of the product at no charge to you, provided you return it during the warranty period, transportation charges prepaid, to the factory direct. Please attach your name, address, telephone number, a description of the problem and a copy of the bill of sale or sales receipt as proof of date of original retail purchase, to each product returned to warranty service.

This Limited Warranty does not apply if the product has been damaged by accident, abuse, misuse or misapplication or has been modified without the written permission of KVH; if any KVH serial number has been removed or defaced; or if any factory-sealed part of the system has been opened without authorization.

THE EXPRESS WARRANTIES SET FORTH ABOVE ARE THE ONLY WARRANTIES GIVEN BY KVH WITH RESPECT TO ANY PRODUCT FURNISHED HEREUNDER; KVH MAKES NO OTHER WARRANTIES, EXPRESS, IMPLIED OR ARISING BY CUSTOM OR TRADE USAGE, AND SPECIFICALLY DISCLAIMS ANY WARRANTY OF MERCHANTABILITY OR OF FITNESS FOR A PARTICULAR PURPOSE. SAID EXPRESS WARRANTIES SHALL NOT BE ENLARGED OR OTHERWISE AFFECTED BY TECHNICAL OR OTHER ADVICE OR SERVICE PROVIDED BY KVH IN CONNECTION WITH ANY PRODUCT.

KVH's liability in contract, tort or otherwise arising out of or in connection with any product shall not exceed the price paid for the product. **IN NO EVENT SHALL KVH BE LIABLE FOR SPECIAL, PUNITIVE, INCIDENTAL, TORT OR CONSEQUENTIAL DAMAGES OR LOST PROFITS OR GOODWILL (INCLUDING ANY DAMAGES RESULTING FROM LOSS OF USE, DELAY IN DELIVERY OR OTHERWISE) ARISING OUT OF OR IN CONNECTION WITH THE PERFORMANCE OR USE OR POSSESSION OF ANY PRODUCT, OR ANY OTHER OBLIGATIONS RELATING TO THE PRODUCT, EVEN IF KVH HAS BEEN ADVISED OF THE POSSIBILITY OF SUCH DAMAGES.**

If any implied warranty, including implied warranties of merchantability and fitness for a particular purpose, cannot be excluded under applicable law, then such implied warranty shall be limited in duration to ONE (1) YEAR from the date of the original retail purchase of this product by the original purchaser.

Some states do not allow the exclusion or limitation of implied warranties or liability for incidental or consequential damages, so the above limitations may not apply to you. This warranty gives you specific legal rights, and you may also have other rights which vary from state to state.

BUYER PROTECTION PLAN

In addition to the foregoing warranty, KVH will provide to the original purchaser an additional TWO (2) years limited coverage under the "Buyer Protection Plan (BPP)". During these two years, KVH will repair or replace any defective component for a fixed price, provided you return it during the BPP period, transportation charges prepaid, to the factory direct. Please attach your name, address, telephone number, a description of the problem and a copy of the bill of sale or sales receipt as proof of date of original retail purchase, to each product returned to warranty service.

This BPP does not apply if the product has been damaged by accident, abuse, misuse or misapplication or has been modified without the written permission of KVH; if any KVH serial number has been removed or defaced; or if any factory-sealed part of the system has been opened without authorization.

8. Remote Display Template

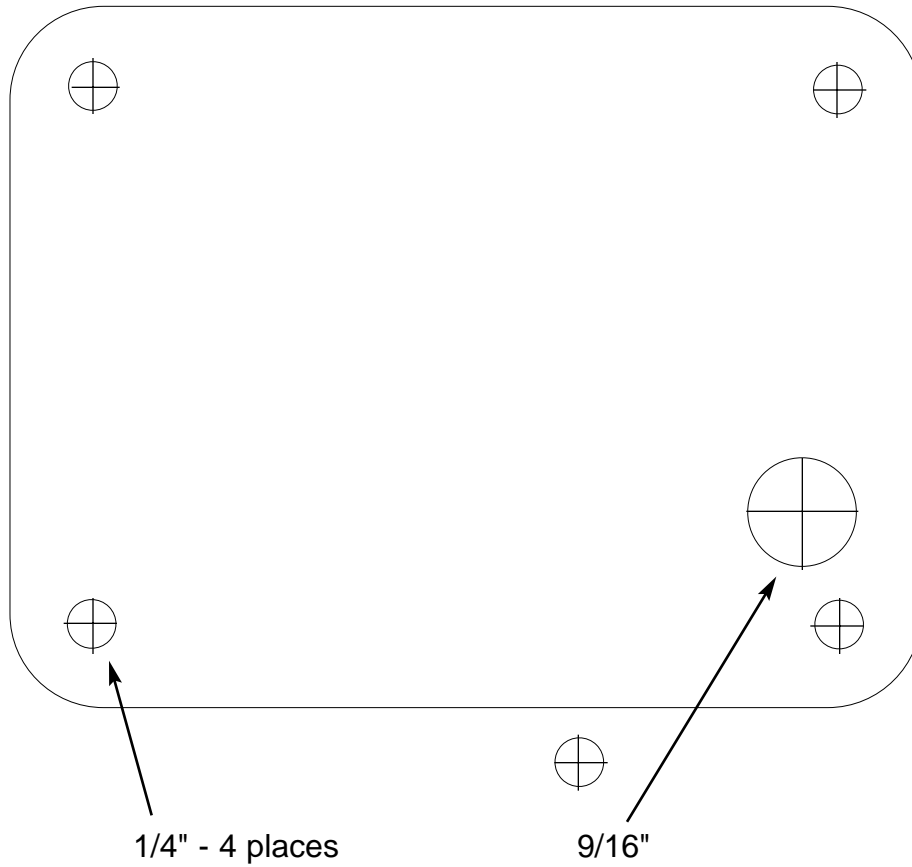

cut along here

9. Remote Keypad Template

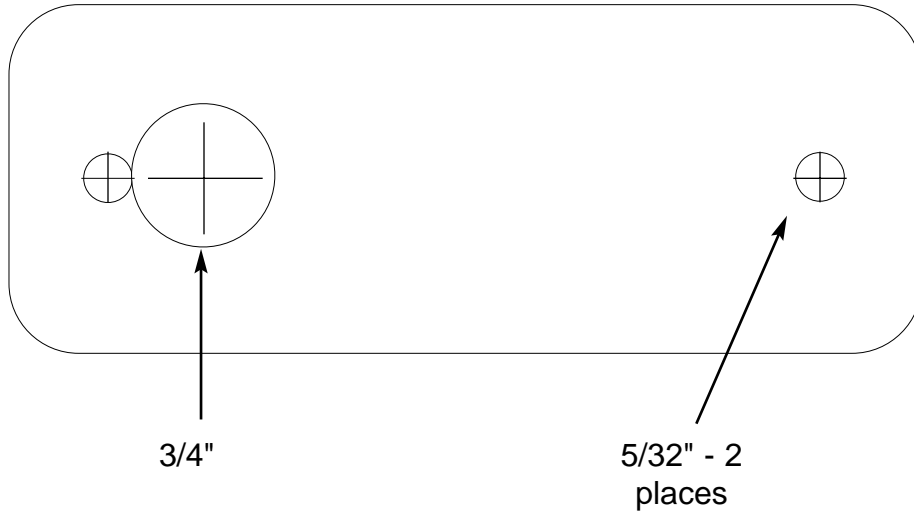

cut along here