



Master User Manual for RIPTIDE SP

Bowmount CoPilot™ PowerDrive™ Saltwater Trolling Motors



NOTE: DO NOT RETURN YOUR MINN KOTA MOTOR TO YOUR RETAILER. YOUR RETAILER IS NOT AUTHORIZED TO REPAIR OR REPLACE THIS UNIT. YOU MAY OBTAIN SERVICE BY:

- CALLING MINN KOTA AT: 1-800-227-6433 OR 1-507-345-4623;
- RETURNING YOUR MOTOR TO THE MINN KOTA FACTORY SERVICE CENTER;
- SENDING OR TAKING YOUR MOTOR TO ANY MINN KOTA AUTHORIZED SERVICE CENTER ON ENCLOSED LIST. PLEASE INCLUDE PROOF OF PURCHASE, SERIAL NUMBER AND PURCHASE DATE FOR WARRANTY SERVICE WITH ANY OF THE ABOVE OPTIONS.

SERIAL NUMBER _____

PURCHASE DATE _____

PLEASE THOROUGHLY READ THIS USER MANUAL. FOLLOW ALL INSTRUCTIONS AND HEED ALL SAFETY & CAUTIONARY NOTICES BELOW. USE OF THIS MOTOR IS ONLY PERMITTED FOR PERSONS THAT HAVE READ AND UNDERSTOOD THESE USER INSTRUCTIONS. MINORS MAY USE THIS MOTOR ONLY UNDER ADULT SUPERVISION.

Power Drive

Feature Information	pg 2-3
Installation	pg. 4
Operation	pg 5
Cautions	pg. 6
Battery Information	pg. 6
Battery Connection	pg. 7
Circuit Breaker	pg. 7
Wiring Diagram	pg. 8
Transducer	pg. 9
Maintenance	pg. 9
Propeller Replacement	pg. 10
Maximizer	pg. 10
Troubleshooting	pg. 10
Limited Warranty	pg. 18

CoPilot

Feature Information	pg 11
Adding/Removing Remotes	pg. 12
Misc. Information	pg. 13
Battery Replacement	pg. 13
General Operation	pg. 14
Audio Modes	pg. 14
Troubleshooting	pg. 14-15
Technical Assistance,	pg. 16
FAQ's	pg. 17
FCC Disclaimer	pg. 18
Limited Warranty	

COPILOT REMOTE

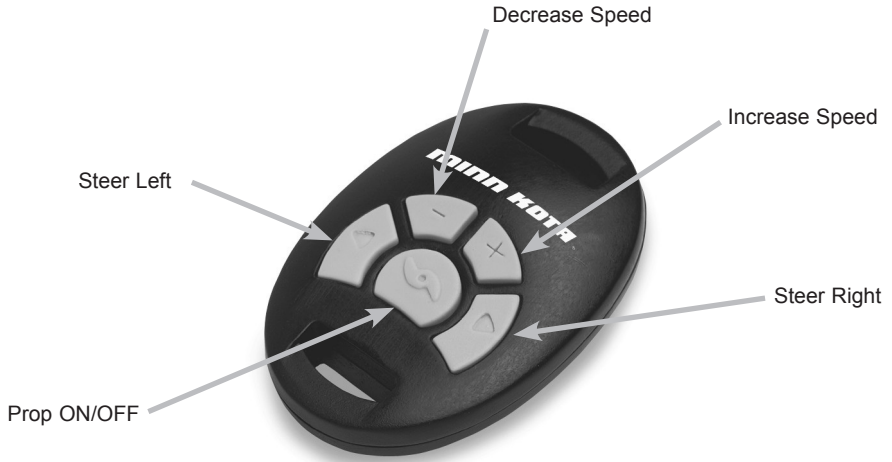

COPILOT RECEIVER

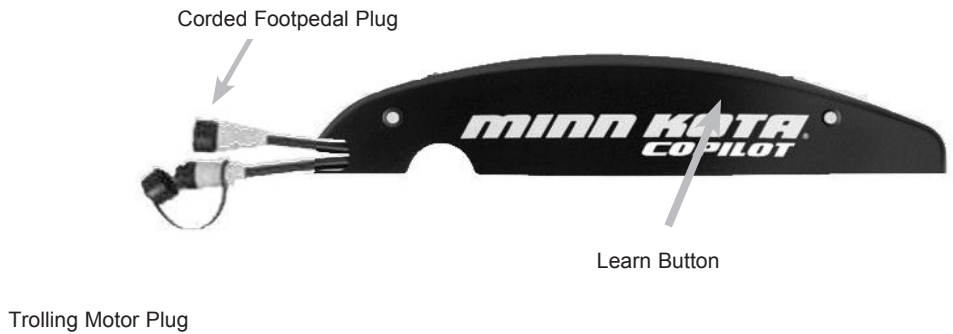

Specifications subject to change without notice.

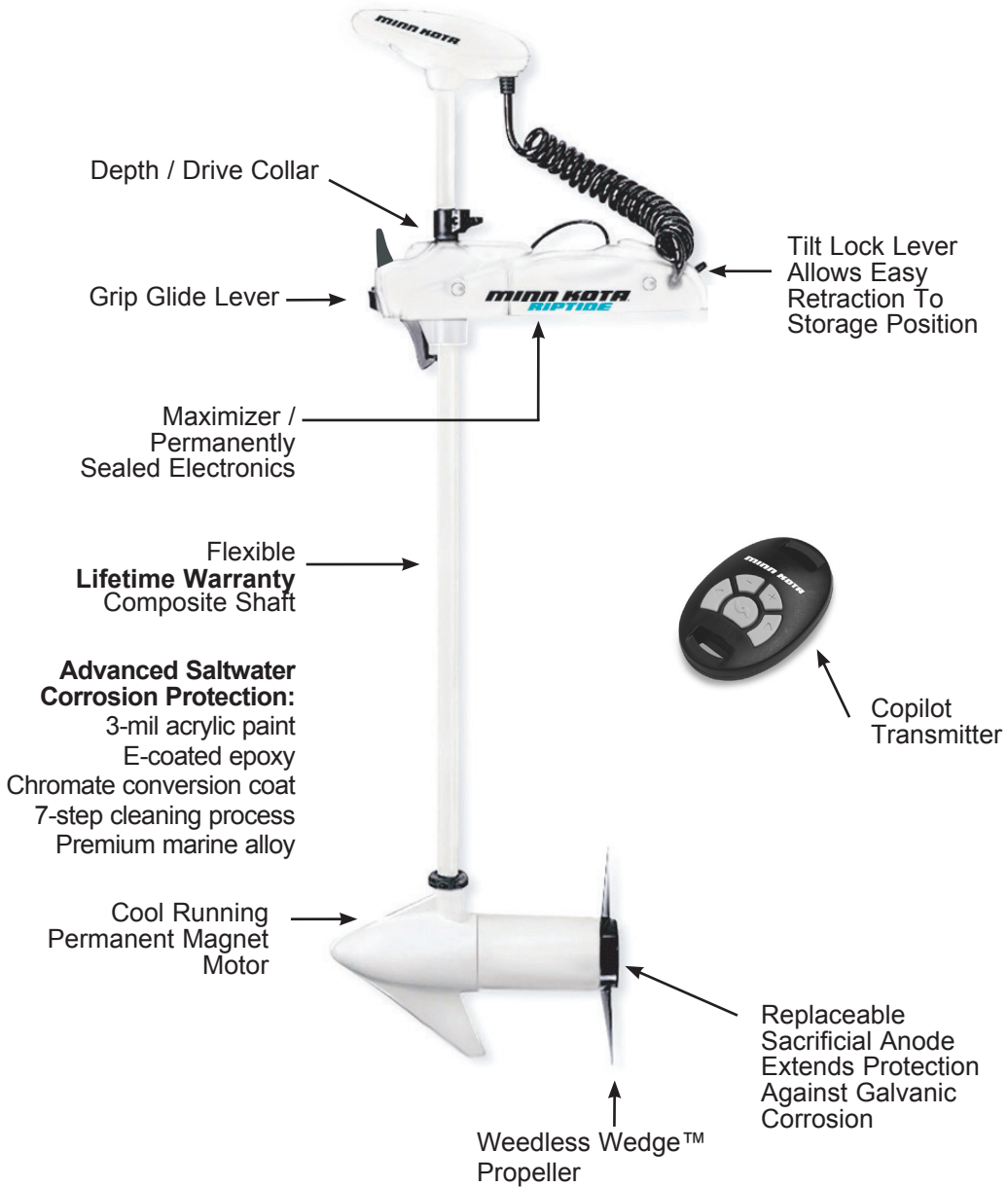

INSTALLATION:

We recommend that you have another person help with this procedure. Tools required: 7/16" wrench, #3 phillips screwdriver and electric drill with a 9/32" bit.

1. Remove the four sideplate screws. Remove the right sideplate and swing the left sideplate out and away from the base extrusion.
2. Place the motor on the bow of the boat in the deployed position:
 - We recommend that the motor be mounted as close to the centerline of the boat as possible.
 - Make sure the bow area under the mounting location is clear and unobstructed for drilling and accessible for you to attach the nuts and washers.
3. Once in position, mark four of the twelve holes provided in the bow mount base for drilling. If possible, use the four holes that are farthest apart. Drill through the marked holes using a the 9/32" drill bit.
4. Mount the plate to the bow using the provided bolts, nuts and washers.
5. Replace the sideplates and sideplate screws.

- Make sure the mount is positioned so that the shaft is out beyond the rub strip of the boat by 1 1/2". The lower unit, as it is lowered into the water or raised into the boat, must not encounter any obstructions.



Mount Bracket so that during stow and deploy, the shaft will not encounter boat's rub strip.

The latch collar is adjustable. If needed, loosen the Phillips head screw and rotate the collar up or down to change the motor's position on the ramps.

CAUTION: MAKE SURE YOU MOUNT YOUR MOTOR ON A LEVEL SURFACE. USE THE RUBBER WASHERS TO CREATE A LEVEL SURFACE — IF NECESSARY.

TO STOW:

Push down to release tilt lock lever and raise the motor by pulling up on the composite shaft or control head. Pull the motor toward the stern until it rests securely on the ramp and the Grip Glide Lever captures the collar.

TO DEPLOY:

Push firmly down on the Grip Glide lever to release the collar and slide the motor forward, out from the ramp. Lower the motor to the desired depth. Make sure it clicks into a secure, vertical position.

TO ADJUST DEPTH:

Firmly grasp and hold the composite shaft above the PowerDrive housing. Loosen the depth/drive collar knob until the shaft slides freely. Raise or lower the motor to the desired depth. Tighten the depth/drive collar knob to secure the motor in place.

WARNING: WHEN RAISING OR LOWERING MOTOR, KEEP FINGERS CLEAR OF ALL HINGE AND PIVOT POINTS AND ALL MOVING PARTS.

TO ADJUST LATCH COLLAR:

The latch collar is adjustable. If needed, loosen the Phillips head screw and rotate the collar up or down to re-align the latch and collar. The ideal adjustment is a slightly loose fit that completely captures the collar.

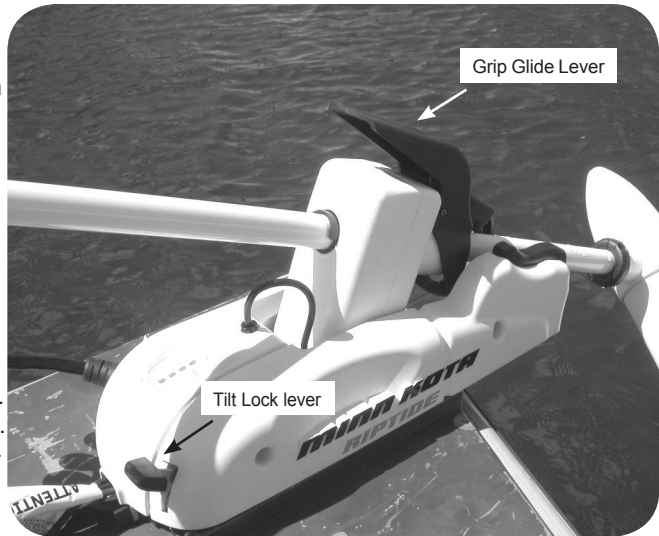

Attention:

- Avoid running your motor with the propeller outside of the water. This may result in injuries from the rotating propeller.
- It is recommended to set the speed selector to zero and place the motor in the deployed position prior to connecting power cables. Disconnect power cables prior to stowing.
- Always ensure that the power cables are not twisted or kinked; and that they are securely routed to avoid a safety or trip hazard. Ensure cables are unobstructed in all locations to avoid damaging the wire insulation. Damage to the insulation could result in failure or injury.
- Always inspect the insulation of the power cables prior to use to ensure they are not damaged.
- Disregarding these safety precautions may result in an electrical short of the battery(s) and/or motor. Always disconnect the motor from the battery(s) before cleaning or checking the propeller.
- Avoid submerging the complete motor as water may enter the lower unit through control head and shaft. Water in the lower unit may cause an electrical short and damage the lower unit. This damage will not be covered by warranty.

Caution!

- Always operate the motor in a safe distance away from obstructions. Never approach the motor when the propeller is running. Contact with a spinning propeller may endanger you or others.
- Always exercise safe practices when using your motor; stay clear of other watercrafts, swimmers, and any floating objects. Always obey water regulations applicable to your area of operation.
- Never operate the motor while under the influence of alcohol, drugs, medication, or other substances which may impair your ability to safely operate equipment.
- This motor is not suitable for use in strong currents exceeding the thrust level of the motor.

The constant noise pressure level of the motor during use is less than 70dB(A). The overall vibration level does not exceed 2,5m/sec².

BATTERY INFORMATION:

The motor will operate with any deep cycle marine 12 volt battery/batteries. For best results use a deep cycle, marine battery with at least a 115 ampere hour rating. As a general on the water estimate, your 12 volt motor will draw one ampere per hour and your 24 volt motor will draw .75 ampere per hour for each pound of thrust produced when the motor is running on high. The actual ampere draw is subject to your particular environmental conditions and operation requirements. Maintain battery at full charge. Proper care will ensure having battery power when you need it, and will significantly improve the battery life. Failure to recharge lead-acid batteries (within 12-24 hours) is the leading cause of premature battery failure. Use a variable rate charger to avoid overcharging.

If you are using a crank battery to start a gasoline outboard, we recommend that you use a separate deep cycle marine battery/batteries for your Minn Kota trolling motor.

Advice regarding batteries:

Never connect the (+) and the (-) terminals of the battery together. Take care that no metal object can fall onto the battery and short the terminals. This would immediately lead to a short and utmost fire danger.

Recommendation: Use battery boxes and covered battery terminal clamps like Minn Kota accessory #MK-BC-1.

BATTERY CONNECTION:

12 Volt Systems: RT55

1. Make sure that the motor is switched off (speed selector on "0").
2. Connect positive (+) red lead to positive (+) battery terminal.
3. Connect negative (-) black lead to negative (-) battery terminal.
4. For safety reasons do not switch the motor on until the propeller is in the water.

24 Volt Systems: RT70

1. Make sure that the motor is switched off (speed selector on "0").
2. Two 12 volt batteries are required.
3. The batteries must be wired in series, only as directed in wiring diagram, to provide 24 volts.
 - a. Connect a connector cable to positive (+) terminal of battery 1 and to negative (-) terminal of battery 2.
 - b. Connect positive (+) red lead to positive (+) terminal on battery 2.
 - c. Connect negative (-) black lead to negative (-) terminal of battery 1.
4. For safety reasons do not switch the motor on until the propeller is in the water.

If installing a leadwire plug, observe proper polarity and follow instructions in your boat owner's manual.

See wiring diagrams on following page.

- IMPROPER WIRING OF 24 VOLT SYSTEM COULD CAUSE BATTERY EXPLOSION!
- KEEP LEADWIRE WING NUT CONNECTION TIGHT AND SOLID TO BATTERY TERMINALS.
- LOCATE BATTERY IN A VENTILATED COMPARTMENT.

Boat Rigging and Motor Installation:

An over-current protection device (circuit breaker or fuse) must be used with this motor. Coast Guard requirements dictate that each ungrounded current-carrying conductor must be protected by a manually reset, trip-free circuit breaker or fuse. The type (voltage and current rating) of the fuse or circuit breaker must be sized accordingly to the trolling motor used. The following breaker sizes are recommended guidelines:

Maximum thrust Voltage / Recommended circuit breaker rating

- 30# to 45# 12V 50A @ 12VDC
- 50# to 55# 12V 60A @ 12VDC
- 65# to 70# 24V 50A @ 24VDC
- 80# 24V 60A @ 24VDC
- 101# 36V 50A @ 36VDC
- E-Drive 48V 40A @ 48VDC

The appropriate wire size needed to connect your trolling motor to the trolling motor batteries varies depending on the length of cable needed and voltage of the motor. For additional information, please consult appropriate ABYC (American Boat and Yacht Council) and Coast Guard requirements.

Reference:

United States Code of Federal Regulations: 33 CFR 183 – Boats and Associated Equipment
ABYC E-11: AC and DC Electrical Systems on Boats

12-24 VOLT MODELS

THIS IS A UNIVERSAL MULTI-VOLTAGE DIAGRAM. DOUBLE CHECK YOUR MOTORS VOLTAGE FOR PROPER CONNECTIONS

Over-Current Protection Devices not shown in illustrations.

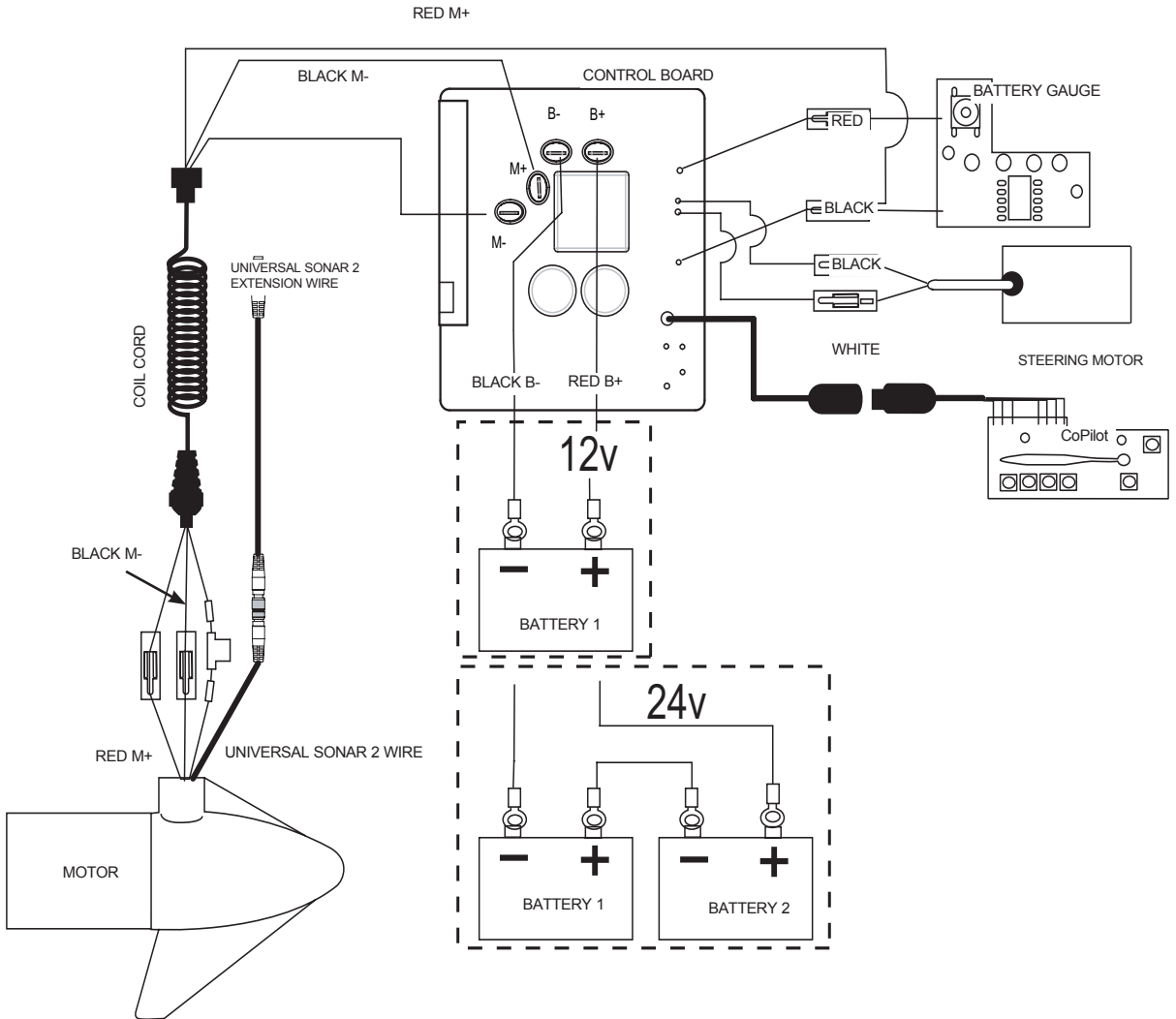

NOTE:
 1. BATTERY 2 AND CONNECTING WIRE USED FOR 24V APPLICATIONS ONLY
 2. UNIVERSAL SONAR 2 WIRES APPLICABLE TO US2 MOTORS ONLY

TRANSDUCER INSTALLATION:

Transducer cables should be routed through the coil cable as shown. Leave enough slack for proper deployment and retraction. Mount transducer according to transducer instructions.

NOTE: A transducer is not included with your trolling motor.

IN STOWED CONDITION:

In conditions where the stowed motor is subject to high levels of shock or vibration, take care to provide a secure stow. Move the depth collar snug against the steering motor and tighten.

MAINTENANCE:

1. After use in salt or brackish water these units should be rinsed with fresh water, then wiped down with a cloth dampened with an aqueous based silicone spray such as Armor All®.
2. The propeller must be cleaned of weeds and fishing line. The line can get behind the prop, wear away the seals and allow water to enter the motor. Check this after every 20 hours of operation.
3. To prevent accidental damage during trailering or storage, disconnect the battery whenever the motor is off of the water. For prolonged storage, lightly coat all metal parts with silicone spray.
4. For maximum performance, restore battery to full charge before each use. Unless you are using a power panel or MINN KOTA battery charger, disconnect the trolling motor when charging the battery.
5. The composite shaft requires periodic cleaning and lubrication for proper retraction and deployment. A coating of Armorall® will provide "like new" operation.
6. Replace the sacrificial anode / nut and washer after 2000 hours of run time or 1.5 seasons, whichever comes first. See Propeller Replacement, steps 1 - 2 and 5 - 6.

NOTICE: DO NOT APPLY LUBRICANT OR ANY TYPE OF GREASE TO TROLLING MOTOR CONNECTORS

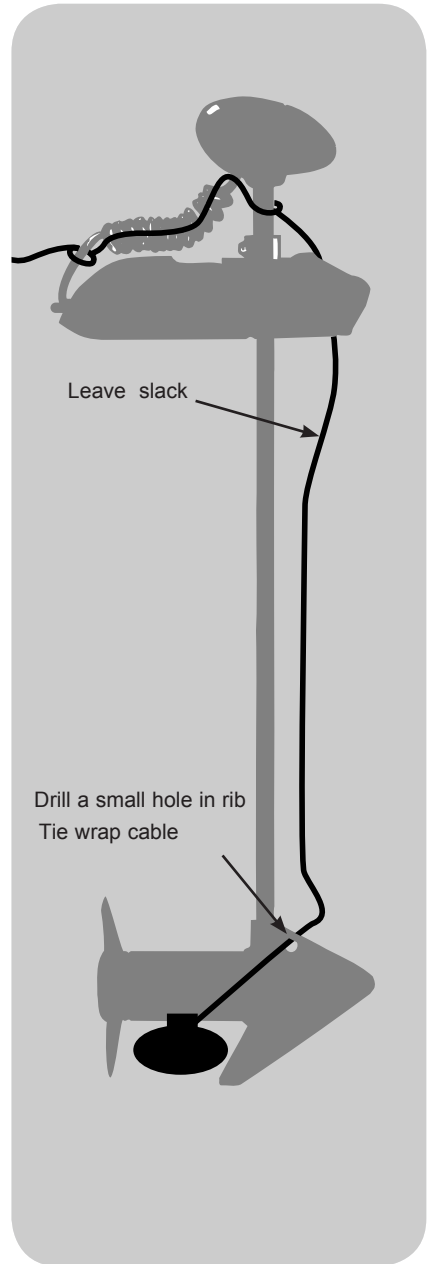

PROPELLER REPLACEMENT:

- Disconnect motor from battery prior to changing the propeller.
- Hold the propeller and loosen the anode/nut with a wrench.
- Remove anode/nut and washer. If the drive pin is sheared/broken, you will need to hold the shaft steady with a screwdriver blade pressed into the slot on the end of the shaft.
- Turn the old prop to horizontal (as illustrated) and pull it straight off. If drive pin falls out, push it back in.
- Align new propeller with drive pin.
- Install prop washer and anode/nut.
- Tighten anode/nut 1/4 turn past snug. [25-35 inch lbs.] Be careful, over tightening can damage prop.

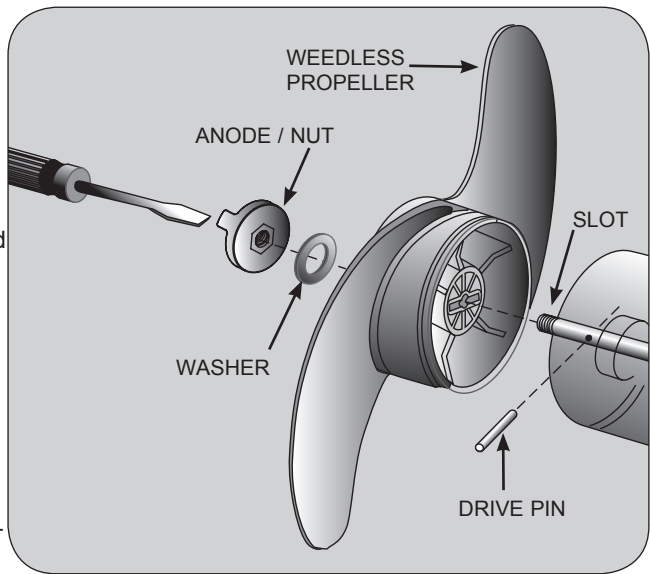

NOTE: The weedless wedge propeller is designed to provide absolute weed free operation with very high efficiency. To maintain top performance, the leading edge of the blades must be kept smooth. If this edge is rough or nicked, restore to smooth by sanding with fine sandpaper.

CAUTION: DISCONNECT THE MOTOR FROM THE BATTERY BEFORE BEGINNING ANY PROP WORK OR MAINTENANCE.

MAXIMIZER™:

The built-in Maximizer's electronics create pulse width modulation to provide longer running time and extended battery life. With the Maximizer speed control, you may, in some applications, experience interference in your depth finder display. We recommend that you use a separate deep cycle marine battery for your trolling motor and that you power the depth finder from the starting / cranking battery. If problems still persist, call our service department at 1-800-227-6433.

MOTOR TROUBLESHOOTING:

1. Motor fails to run or lacks power:
 - Check battery connections for proper polarity.
 - Make sure that the terminals are clean and corrosion free.
 - Check the battery water level. Add water if needed.
2. Motor loses power after a short running time:
 - Check battery/batteries charge, if low, restore to full charge.
3. Motor does not steer.
 - Make sure the drive/depth collar is tight and fully engaged with the drive motor.
4. Motor does not respond to CoPilot commands.
 - Make sure the cable connector plugs at the drive mount are secure.
5. Control head vibrates during normal operation:
 - Remove and rotate the prop 180°. See removal instructions in prop section.

COPILOT™ FEATURES

- Wireless control for PowerDrive and AutoPilot motors with the round plug.
- Functions include steering (right/left), prop on / off, and speed control.
- Remote allows motor to be controlled from anywhere in the boat.
- Quick-release rod mounts allow quick and easy transfer of remote from rod to rod.
- CoPilot can be used with or without the corded foot pedal.
- Remotes will not interfere with the AutoPilot or Universal Sonar operation.
- Up to 10 remotes can be used interchangeably with the same receiver.
- Remotes provides finer steering adjustments than the corded foot pedal.
- Components are environmentally sealed to protect against rain, wind or snow.



ONLY COMPATIBLE WITH SEALED ROUND CONNECTOR

Adding / Removing remotes

- To “learn” the ID number of additional remotes, follow these steps:
 - 1.) Press and hold the **LEARN** button located on the side of the receiver (receiver will emit a continuous tone.)
A small blunt object must be used to depress the **LEARN** button (pen or screwdriver.)
 - 2.) Press any button on the remote (receiver will beep 4 times confirming that it has “learned” the ID number of the remote and that the programming is valid and complete.)



- “Re-learning” the ID number of the same remote will not overwrite previously “learned” remotes.
- If the receiver has “learned” the ID number of ten remotes, “learning” an eleventh remote will erase or over write the first “learned” remote.
- The CoPilot allows the angler to erase all stored remote ID numbers from the receiver. To do so, follow these steps:
 - 1.) Remove power from the receiver by unplugging the receiver from the motor.
 - 2.) Press and hold the **LEARN** button and power up the receiver by plugging it back into the motor. Hold the **LEARN** button down for 10 seconds. During this time the receiver audio will emit a warble sound, slowly transition to a constant beep and then shut off.
 - 3.) Release the Learn button and the receiver will reboot. The receiver will emit a 2 second long beep indicating memory is empty. This audio pattern will occur each time the receiver powers up until a remote ID number is learned.

MISCELLANEOUS INFORMATION

- The five buttons are for **PROP ON/OFF**, **STEER LEFT**, **STEER RIGHT**, **INCREASE SPEED** AND **DECREASE SPEED**.
- Pressing the **PROP ON/OFF** button will turn the propeller on or off. The button does not need to be held down. (Press the button once to turn the motor ON; press button a second time to turn it OFF.)
- Pressing either **STEERING** button will cause the motor to turn in the desired direction as long as the button is held down. If a steering button is held for more than seven seconds, the steering will automatically stop.
- Pressing and releasing the **INCREASE SPEED** or **DECREASE SPEED** buttons will cause the speed to increase or decrease by one level. The speed is adjustable from level 0-10. At level 0, the prop *will not* turn.
- An audible beep is heard for each step change in speed. Attempting to go higher than speed 10 or lower than speed 0 will result in the speed not changing and no beep will be heard. See the Audio Mode section for more information.
- If the receiver senses no foot pedal or remote operation for 1 hour, the remote speed setting is automatically set to zero. This could help prevent unintentional activation of the propeller if the prop on /off remote button is inadvertently pressed or bumped while in storage.

BATTERY REPLACEMENT

THE REPLACEMENT BATTERY MUST BE A MODEL CR2032 COIN CELL TYPE. IT IS STRONGLY RECOMMENDED THAT A NAME BRAND BATTERY IS USED.

To replace the battery, follow these steps:

- 1.) Temporarily ground yourself by touching a grounded metal object in order to discharge any static electricity in your body.
- 2.) Remove the four screws on the bottom of the remote case.
- 3.) Separate the case halves to access the circuit board.
- 4.) Pull back the retaining fingers of the battery holder to remove the battery (underside of circuit board.)
- 5.) Install the new battery with the positive (+) side of the battery facing up (away from the circuit board).
Ensure battery is snapped securely in place.
- 6.) Reassemble the remote. Note that the alignment peg in the remote case must line up with the corresponding alignment hole in the circuit board. Also note that the keypad must be positioned so that the buttons are over the end of the circuit board opposite from the alignment peg and hole. Reinstall the four case screws and tighten them as required.

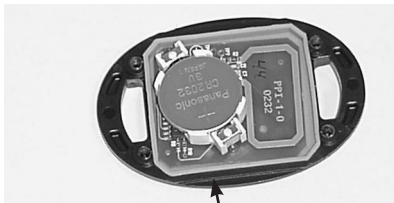

BATTERY

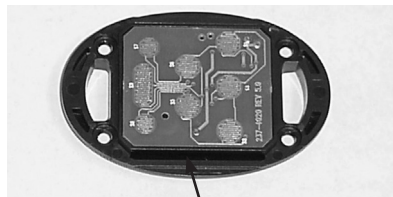

ALIGNMENT PEG

GENERAL OPERATION

Using the CoPilot with a corded foot pedal

When the foot pedal's MOM-CON switch is in the CON position or when the Momentary On switch is held, the receiver WILL NOT RESPOND to any remote commands. When remote commands are received, the receiver will emit an audio chirp. This will indicate that the remote is functioning properly although a foot pedal switch is active and is overriding the remote.

- When the MOM-CON switch is in the MOM position, the angler may begin using the remote at any time.
- As soon as any remote button is pressed, the initial speed setting will be approximately the same as the foot pedal's speed control position. However, the prop will not automatically turn on until the remote's prop on/off button is pressed.
- Pressing the corded foot pedal momentary switch or steering switches will override the remote and receiver function and control will automatically go to the corded foot pedal. The prop speed will also revert to the current position of the speed control on the foot pedal.

Using the CoPilot without a corded foot pedal

- Some anglers will prefer to have the deck completely clear of any unnecessary cables and foot pedals. When using the Copilot in this manner, the receiver will always react to any commands from the remote.

AUDIO MODES

UNIT IS FACTORY PRE-SET TO AUDIO MODE 2.

- There are three receiver audio modes available. To switch from one audio mode to another, press and hold both the **INCREASE** and **DECREASE** speed buttons on the remote down for one second. The receiver will respond with 1, 2 or 3 audible beeps indicating the corresponding receiver audio mode change.
 Audio Mode 1 = All of the normal audible sounds mentioned in this owners manual.
 Audio Mode 2 = Same as audio mode 1 plus an audible beep for speed increase / decrease and prop on/off.
 Audio Mode 3 = Same as audio mode 2 plus the prop on audible click every few seconds.

NOTE : WHEN THE CORDED FOOT PEDAL IS IN CONTROL AND THE PROPELLER IS ON, THE PROP ON INDICATOR CLICK WILL BE HEARD IF THE RECEIVER IS SET TO AUDIO MODE 3.

COPILOT TROUBLESHOOTING

AUDIO PATTERN	WHAT CONDITION CAUSES IT	OCCURS IN WHICH AUDIO MODE
1 beep	Pressing the INCREASE SPEED or DECREASE SPEED button.	Modes 2 and 3
1 beep	Pressing the PROP ON/OFF button to turn the prop on.	Modes 2 and 3
2 beeps	Pressing the PROP ON/OFF button to turn the prop off.	Mode 2 and 3
Single tick every 1.5 sec.	When the prop is active including when speed is set to 0.	Mode 3
1 beep	Switching to Audio Mode 1 (pressing the INCREASE SPEED and DECREASE SPEED buttons simultaneously for 1 second.)	All
2 beeps	Switching to Audio Mode 2 (pressing the INCREASE SPEED and DECREASE SPEED buttons simultaneously for 1 second.)	All
3 beeps	Switching to Audio Mode 3 (pressing the INCREASE SPEED and DECREASE SPEED buttons simultaneously for 1 second.)	All
1 chirp	Every time the receiver is powered up and there is at least one remote ID learned.	All

AUDIO PATTERN	WHAT CONDITION CAUSE IT	OCCURS IN WHICH AUDIO MODE
2 second long beep	Every time the receiver is powered up an there are no remote IDs learned.	All
1 chirp	When foot pedal is in the CON position all remote commands from the remote will be ignored.	All
5 beeps	Foot pedal speed control is moved while in remote mode.	All
Steady tone	Heard while holding down the learn button on the receiver.	All
4 beeps	After a remote button is pressed while the receiver learns it's ID.	All
A ten second long warbling sound that transitions into a steady tone	Heard during the process used to clear all stored remote IDs. After the learn switch is released, a 2 second long beep will be heard.	All
1 long beep 2 short beeps, pause, (repeat)	Powered up with MOM/CON in the CON position (or mom switch held). When the foot pedal is moved to momentary, the power up audio will be heard.	All

CAUSE	EFFECT	SOLUTION
REMOTE IS NOT TRANSMITTING	The battery is discharged	Replace battery
	Receiver may not have "learned" the ID number of the remote.	Remote needs to be learned. See "ADDING/REMOVING REMOTES" section to learn the remote ID number.
	With the foot pedal connected, the MOM-CON switch is in the CON position. An audio response will be heard if a button is pressed with the foot pedal in the CON position.	The foot pedal switch must be placed in the MOM position. The receiver will not accept any commands from the remote with the switch in the CON position
	If remote has been taken apart, the keypad and top case may have been installed backwards.	Take remote apart (BATTERY REPLACEMENT SECTION) and reinstall case halves with the proper orientation.
WHEN RECEIVER IS POWERED UP, IT SOUNDS A BEEP PATTERN. (1 long beep, 2 short beeps, pause, repeat)	The foot pedal MOM-CON switch is in the CON position	The foot pedal switch must be placed in the MOM position. The beeping sound will continue until the switch is placed in the MOM position
THE PROP IS NOT TURNING BUT THE "PROP ON" AUDIO TICK IS STILL GOING	Prop speed is set at "0"	Increase the prop speed above "0"
	Prop ON tick occurs only in Audio mode 3	Switch Audio mode to either Audio 1 or 2. See "Audio Modes" section.

TECHNICAL ASSISTANCE

Do not take your CoPilot receiver or remote to your dealer or to a Minn Kota Authorized Service Center for repair or replacement. The CoPilot remote has no field replaceable or user serviceable parts, (other than battery replacement). For service/technical assistance call 1-800-227-6433, or send the CoPilot receiver and remote(s) along with proof of purchase date to: Johnson Outdoors- MinnKota Service, 121 Power Drive, Mankato MN 56002-8129

FREQUENTLY ASKED QUESTIONS

- Q.** Are there any on/off switches?
A. No. The receiver is always powered up whenever the motor is connected to the battery or batteries. The remote automatically goes into a low power “sleep mode” whenever there are no buttons being pressed.
- Q.** Does the remote float?
A. The remote will float by itself.
- Q.** Can other CoPilot users control my CoPilot if they get too close?
A. No. Each remote has its own unique ID number, your CoPilot receiver will not respond to commands from other “unlearned” remotes.
- Q.** How many remote ID numbers can my receiver “learn”?
A. 10
- Q.** What happens if my receiver has 10 different remote ID numbers “learned” and I attempt to “teach” it another one?
A. The first remote ID number that was learned will be erased (first in, first out).
- Q.** Can I turn the AutoPilot function on and off using CoPilot?
A. No. CoPilot only controls those functions that are available on the foot pedal.
- Q.** How long should the battery in the remote last?
A. Under normal use and conditions, the battery should last for at least two regular fishing seasons.
- Q.** Where can I purchase additional remotes?
A. Through any regular Minn Kota retail outlet.

FCC DISCLAIMER

Compliance Statement (Part 15.19)

This device complies with Part 15 of the FCC Rules and with RSS-210 of Industry Canada. Operation is subject to the following two conditions:

1. This device may not cause harmful interference, and
2. This device must accept any interference received, including interference that may cause undesired operation.

Warning (Part 15.21)

Changes or modifications not expressly approved by the party responsible for compliance could void the user's authority to operate the equipment.

Industry Canada Statement

The term "IC" before the certification/registration number only signifies that the Industry Canada technical specifications were met.

LIMITED LIFETIME WARRANTY ON COMPOSITE SHAFT, LIMITED TWO-YEAR WARRANTY ON ENTIRE PRODUCT:

Composite Shaft

Johnson Outdoors Marine Electronics, Inc. warrants to the original purchaser that the composite shaft of the purchaser's Minn Kota® trolling motor is free from defects in materials and workmanship appearing within the original purchaser's lifetime. Johnson Outdoors Marine Electronics, Inc. will provide a new shaft, free of charge, to replace any composite shaft found to be defective more than two (2) years after the date of purchase. Providing such a new shaft shall be the sole and exclusive liability of Johnson Outdoors Marine Electronics, Inc. and the sole and exclusive remedy of the purchaser for breach of this warranty; and purchaser shall be responsible for installing, or for the cost of labor to install, any new composite shaft provided by Johnson Outdoors Inc.

Entire Product

Johnson Outdoors Marine Electronics, Inc. warrants to the original purchaser that the purchaser's entire Minn Kota® trolling motor is free from defects in materials and workmanship appearing within two (2) years after the date of purchase. Johnson Outdoors Marine Electronics, Inc. will, at its option, either repair or replace, free of charge, any parts, including any composite shaft, found to be defective during the term of this warranty. Such repair or replacement shall be the sole and exclusive liability of Johnson Outdoors Marine Electronics, Inc. and the sole and exclusive remedy of the purchaser for breach of this warranty.

Terms Applicable to Both Warranties

These limited warranties do not apply to motors used commercially nor do they cover normal wear and tear, blemishes that do not affect the operation of the motor, or damage caused by accidents, abuse, alteration, modification, misuse or improper care or maintenance. **DAMAGE TO MOTORS CAUSED BY THE USE OF REPLACEMENT PROPELLERS OR OTHER REPLACEMENT PARTS NOT MEETING THE DESIGN SPECIFICATIONS OF THE ORIGINAL PROPELLER AND PARTS WILL NOT BE COVERED BY THIS LIMITED WARRANTY.** The cost of normal maintenance or replacement parts which are not defective

are the responsibility of the purchaser.

To obtain warranty service in the U.S., the motor or part believed to be defective, and proof of original purchase (including the date of purchase), must be presented to a Minn Kota® Authorized Service Center or to Minn Kota®'s factory service center in Mankato, MN. Any charges incurred for service calls, transportation or shipping/freight to/from the Minn Kota® Authorized Service Center or factory, labor to haul out, remove, re-install or re-rig products removed for warranty service, or any other similar items are the sole and exclusive responsibility of the purchaser. Motors purchased outside of the U.S.

must be returned prepaid with proof of purchase (including the date of purchase and serial number) to any Authorized Minn Kota® Service Center in the country of purchase. Warranty service can be arranged by contacting a Minn Kota® Authorized Service Center listed on the enclosed sheet, or by contacting the factory at 1-800-227-6433 or fax 1-800-527-4464. Note: Do not return your Minn Kota® motor to your retailer. Your retailer is not authorized to repair or replace them.

THERE ARE NO EXPRESS WARRANTIES OTHER THAN THESE LIMITED WARRANTIES. IN NO EVENT SHALL ANY IMPLIED WARRANTIES (EXCEPT ON THE COMPOSITE SHAFT), INCLUDING ANY IMPLIED WARRANTIES OF MERCHANTABILITY OR FITNESS FOR PARTICULAR PURPOSE, EXTEND BEYOND TWO YEARS FROM THE DATE OF PURCHASE. IN NO EVENT SHALL JOHNSON OUTDOORS MARINE ELECTRONICS, INC. BE LIABLE FOR INCIDENTAL, CONSEQUENTIAL OR SPECIAL DAMAGES.

Some states do not allow limitations on how long an implied warranty lasts or the exclusion or limitation of incidental or consequential damages, so the above limitations and/or exclusions may not apply to you. This warranty gives you specific legal rights and you may also have other legal rights which vary from state to state.

"WARNING: This product contains chemical(s) known to the state of California to cause cancer and/or reproductive toxicity."

ENVIRONMENTAL COMPLIANCE STATEMENT:

It is the intention of Johnson Outdoors Marine Electronics, Inc. to be a responsible corporate citizen, operating in compliance with known and applicable environmental regulations, and a good neighbor in the communities where we make or sell our products.

WEEE Directive:

EU Directive 2002/96/EC "Waste of Electrical and Electronic Equipment Directive (WEEE)" impacts most distributors, sellers, and manufacturers of consumer electronics in the European Union. The WEEE Directive requires the producer of consumer electronics to take responsibility for the management of waste from their products to achieve environmentally responsible disposal during the product life cycle.

WEEE compliance may not be required in your location for electrical & electronic equipment (EEE), nor may it be required for EEE designed and intended as fixed or temporary installation in transportation vehicles such as automobiles, aircraft, and boats. In some European Union member states, these vehicles are considered outside of the scope of the Directive, and EEE for those applications can be considered excluded from the WEEE Directive requirement.

This symbol (WEEE wheelee bin) on product indicates the product must not be disposed of with other household refuse. It must be disposed of and collected for recycling and recovery of waste EEE. Johnson Outdoors Marine Electronics, Inc. will mark all EEE products in accordance with the WEEE Directive. It is our goal to comply in the collection, treatment, recovery, and environmentally sound disposal of those products; however, these requirements do vary within European Union member states. For more information about where you should dispose of your waste equipment for recycling and recovery and/or your European Union member state requirements, please contact your dealer or distributor from which your product was purchased.



Disposal:

Minn Kota motors are not subject to the disposal regulations EAG-VO (electric devices directive) that implements the WEEE directive. Nevertheless never dispose of your Minn Kota motor in a garbage bin but at the proper place of collection of your local town council.

Never dispose of battery in a garbage bin. Comply with the disposal directions of the manufacturer or his representative and dispose of them at the proper place of collection of your local town council.

BOAT RIGGING AND PRODUCT INSTALLATION:

For safety and compliance reasons, we recommend that you follow American Boat and Yacht Council (ABYC) standards when rigging your boat. Altering boat wiring should be completed by a qualified marine technician. The following specifications are for general guidelines only:

CAUTION: These guidelines apply to general rigging to support your Minn Kota Motor. Powering multiple motors or additional electrical devices from the same power circuit may impact the recommended conductor gauge and circuit breaker size. If you are using wire longer than that provided with your unit, follow the conductor gauge and circuit breaker sizing table below. If your total conductor length is more than 50 feet we recommend that you contact a qualified marine technician.

An over-current protection device (circuit breaker or fuse) must be used. Coast Guard requirements dictate that each ungrounded current-carrying conductor must be protected by a manually reset, trip-free circuit breaker or fuse. The type (voltage and current rating) of the fuse or circuit breaker must be sized accordingly to the trolling motor used. The table below gives recommended guidelines for circuit breaker sizing.

*Conductor Gauge and Circuit Breaker Sizing Table

Total Conductor Length (length of all conductors in the total circuit)

Motor Thrust	Circuit Breaker	10 feet	20 feet	30 feet	40 feet	50 feet
30#	50 Amp @ 12 VDC	12 AWG	10 AWG	8 AWG	6 AWG	4 AWG
40#, 45#		10 AWG	8 AWG	6 AWG	4 AWG	4 AWG
50#, 55#	60 Amp @ 12 VDC	8 AWG	6 AWG	4 AWG	4 AWG	2 AWG
70#	50 Amp @ 24 VDC	10 AWG	10 AWG	8 AWG	8 AWG	6 AWG
80#	60 Amp @ 24 VDC	8 AWG	8 AWG	8 AWG	6 AWG	6 AWG
101#	50 Amp @ 36 VDC	8 AWG	8 AWG	8 AWG	8 AWG	8 AWG
E-Drive	40 Amp @ 48 VDC	10 AWG	10 AWG	8 AWG	6 AWG	6 AWG

***The conductor and circuit breaker sizing table above is only valid for the following assumptions.**

1. No more than 3 conductors are bundled together inside of a sheath or conduit outside of engine spaces.
2. Each conductor has 105°C temp rated insulation.
3. No more than 5% voltage drop allowed at full motor power based on published product power requirements.

Reference:

United States Code of Federal Regulations: 33 CFR 183 – Boats and Associated Equipment
ABYC E-11: AC and DC Electrical Systems on Boats

BATEAU GRÉEMENT ET PRODUIT DE L'INSTALLATION :

Pour des raisons de sécurité et de conformité, nous recommandons de suivre les normes de l'American Boat And Yacht Council (ABYC) lorsque triquer votre bateau. Modifier le câblage du bateau doit être complété par un technicien marin qualifié. Les spécifications suivantes sont uniquement des directives générales :

Avertissement : Ces directives s'appliquent au gréement générale à l'appui de votre moteur Minn Kota. Alimenter plusieurs moteurs ou des dispositifs électriques supplémentaires depuis le même circuit de puissance peut influencer la taille recommandée de la jauge du conducteur et disjoncteur. Si vous utilisez fil plus long que celui fourni avec votre unité, suivre le conducteur jauge et le disjoncteur dimensionnement tableau ci-dessous. Si la longueur totale de votre conducteur est plus de 15 mètres nous recommandons que vous contacter un technicien marin qualifié.

Un dispositif de protection de surintensité (disjoncteur ou fusible) doit être utilisé. Les exigences de la Garde-Côte américain disent que chaque conducteur sans fondement de porteurs de courant doit être protégé par un disjoncteur mise en circuit, à déclenchement libre ou un fusible. Le type (tension et courant nominal) du fusible ou disjoncteur doit être dimensionné en conséquence pour le moteur utilisé. Le tableau ci-dessous donne les directives pour le calibrage de disjoncteur.

* Jauge de conducteur et disjoncteur Table de dimensionnement

Longueur totale de chef d'orchestre (longueur de tous les conducteurs dans le circuit total)

<i>Moteur poussée</i>	<i>Disjoncteur</i>	<i>3 mètres</i>	<i>6 mètres</i>	<i>9 mètres</i>	<i>12 mètres</i>	<i>15 mètres</i>
30#	Amp 50 @ 12 VDC	3 mm	5 mm	8 mm	13 mm	21 mm
40#, 45#		5 mm	8 mm	13 mm	21 mm	21 mm
50#, 55#	Amp 60 @ 12 VDC	8 mm	13 mm	21 mm	21 mm	32 mm
70#	Amp 50 @ 24 VDC	5 mm	5 mm	8 mm	8 mm	13 mm
80#	Amp 60 @ 24 VDC	8 mm	8 mm	8 mm	13 mm	13 mm
101#	Amp 50 @ 36 VDC	8 mm	8 mm	8 mm	8 mm	8 mm
E-Drive	Amp 40 @ 48 VDC	5 mm	5 mm	8 mm	13 mm	13 mm

* Le disjoncteur tableau ci-dessus de dimensionnement et chef d'orchestre est uniquement valable pour les hypothèses suivantes.

1. Pas plus de 3 conducteurs sont regroupés à l'intérieur d'une gaine ou conduites à l'extérieur des espaces de moteur.
2. Chaque conducteur a 105°C temp, évalué à isolation.
3. Pas plus d'une chute de tension de 5 % a permis à la puissance du moteur complet en fonction des besoins de puissance produit publié.

Référence :

United States Code of Federal Regulations : CFR 33 183 – bateaux et équipement connexe
ABYC E-11: AC et DC des systèmes électriques à bord de bateaux

REPAIR AND TROUBLESHOOTING

We offer several options to help you troubleshoot and/or repair your product. Please read through the options listed below.



FREQUENTLY ASKED QUESTIONS

Did you know that we have over 100 FAQ's to help answer all of your Minn Kota questions? Visit www.minnkotamotors.com and click on "Frequently Asked Questions" under the "Service" tab to find an answer to your question.

<http://www.minnkotamotors.com/service/faq.aspx?linkidentifier=id&itemid=817>



AUTHORIZED SERVICE CENTERS

Minn Kota has over 300 authorized service centers in the United States and Canada where you can purchase parts or get your products repaired. Please visit www.minnkotamotors.com and click on "Service Center Locator" under the "Service" tab to locate a service center in your area.

<http://www.minnkotamotors.com/service/asclocator.aspx>



CALL US (FOR U.S. AND CANADA)

Our customer service representatives are available Monday – Friday between 7:00am – 4:30pm CST at 800-227-6433. If you are calling to order parts, please have the 11-character serial number from your product, specific part numbers, and credit card information available. This will help expedite your call and allow us to provide you with the best customer service possible. You can reference the parts list located in your manual to identify the specific part numbers.



EMAIL US

You can email our customer service department with questions regarding your Minn Kota products. To email your question, visit www.minnkotamotors.com and click on "Contact Us" under the "Service" tab.

<http://www.minnkotamotors.com/service/contact.aspx>

RT55/SP
55 LBS THRUST
12 VOLT
48" / 54" SHAFT

This page provides MinnKota® WEEE compliance disassembly instructions. For more information about where you should dispose of your waste equipment for recycling and recovery and/or your European Union member state requirements, please contact your dealer or distributor from which your product was purchased.

Tools required: Flat head screw driver, Phillips screw driver, Socket set, Pliers, Wire cutters.

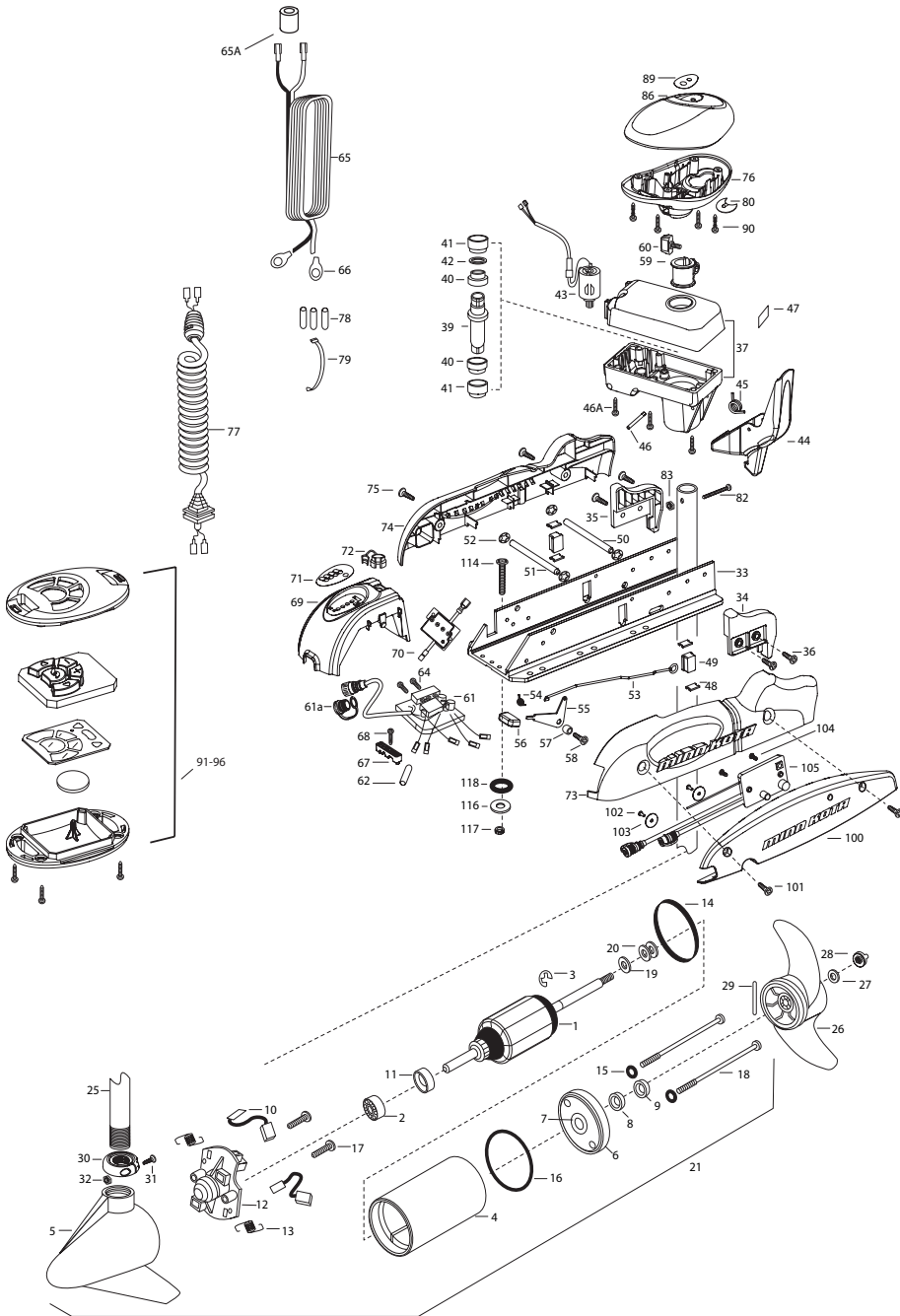

In the U.S.A., replacement parts may be ordered directly from MINN KOTA Parts Dept., 121 Power Drive, P.O. Box 6129, Mankato, Minnesota 56002-8129. In Canada, parts may be ordered from any of the Canadian Authorized Service Centers shown on the enclosed list. Be sure to provide the model and serial numbers of your motor when ordering parts. Please use the correct part numbers from the parts list. Payment for any parts ordered from the MINN KOTA parts department, may be by cash, personal check, Discover Card, MasterCard or VISA. To order, call 1-800-227-6433 or FAX: 1-800-527-4464.

1	2-100-121	ARMATURE ASSEMBLY 12V VARS TXT	*41	2307305	BUSHING- OUTER (2 EA)	78	2065400	WIRE INSULATOR-LGE 1-3/4 (3 EA)
2	140-010	BALL BEARING	*42	2304603	O-RING	79	2256300	TIE WRAP-5" BLACK
3	788-015	RETAINING RING	43	2307060	MOTOR- DRIVE HOUSING HIGH SPD	80	2224703	INSERT- PLUG WHITE
4	2-200-301	HOUSING ASSEMBLY CENTER 3.62 TXT	44	2307201	LATCH HANDLE PD/AP	82	2332102	SCREW-10-24 X 1-3/4
5	421-336	HOUSING -BRUSH END 3.62 TXT	45	2302760	SPRING- LATCH TORSION PD/AP	83	2331101	NUT-HEX 10-24 NYLOC
6	2-400-337	PLAIN END HOUSING ASSEMBLY 3.625	46	2302628	PIN-ROLL 3/16X2 SS	86	2300243	CONTROL BOX COVER-RIPTIDE WHITE
7	144-049	BEARING - FLANGE (SERVICE ONLY)	46A	2309405	SCREW - DRIVE HOUSING (6 EA)	89	2315689	DECAL- COVER 55pd
8	880-003	SEAL	47	2305964	DECAL-STOWIDEPLOY	90	2372100	SCREW-8-18 X .58 THD CUT (4 EA)
9	880-006	SEAL WITH SHIELD	48	2305110	PAD-PIVOT SUPT (4 EA)	■	2994020	COPILOT TRANSMITTER
10	188-038	BRUSH ASSEMBLY (2 EA)	49	2305103	PIVOT PAD- NEW MTRL (2 EA)	91		CASE, COVER, TRANSMITTER
11	725-060	BRUSH RETENTION- PAPER TUBE	50	2330510	PIN-LATCH PD BASE SS	92		KEYPAD
12	738-036	BRUSH PLATE WHOLDER	51	2330520	PIN-PIVOT PD BASE SS	93		CIRCUIT BOARD, TRANSMITTER
13	975-040	SPRING - TORSION (2 EA)	52	2333100	NUT-SPEED (4 EA)	94		BATTERY, COIN
14	337-038	GASKET	53	2303612	ROD-RELEASE RT/AP S	95		CASE, BOTTOM, TRANSMITTER
15	701-008	O-RING, THRU-BOLT (2 EA)	54	2322700	SPRING-RELEASE LEVER	96		SCREW, TRANSMITTER (4 EA)
16	701-081	O-RING	55	2333705	LEVER-RELEASE SS	■	2994089	RECEIVER ASSEMBLY V2, COPILOT
17	830-007	SCREW-8-32 (2 EA)	56	2300101	RELEASE-KNOB	100	2372511	CASE, RECEIVER WHT
18	830-042	THRU-BOLT 10-32X8.83 (2 EA)	57	2301700	SPACER-RELEASE LEVER	101	2379442	SCREW 1/4-20 X 1.75 SS (2 EA)
19	890-067	WASHER- STEEL THRUST	58	2332104	SCREW-1/4-20 X .68 SS	102	2373450	SCREW #6 X 3/8 (2 EA)
20	890-070	WASHER - NYLATRON (2 EA)	59	2031522	COLLAR - DRIVE (WINSERT)	103	2371727	WASHER (2 EA)
21	2097095	MOTOR ASSEMBLY 12V 3.62 48"	60	2011366	SCREW-COLLAR/NEW KNOB SS	104	2373418	SCREW #6 X 5/8 SS
25	2002000	TUBE COMPOSITE WHT 48"	60A	2323104	NUT	105	2374089	CIRCUIT BOARD V2, RECEIVER
2002001	TUBE COMPOSITE WHT 54"		61	2304066	CONTROL BOARD ASSEMBLY-12V/PD	■	2994664	BAG ASSEMBLY - (BOLT,NUT,WASHERS)
■	1378131	PROPELLER KIT	61a	2320208	DUST PLUG	*114	2263462	BOLT-MOUNTING-1/4X2 W/STG (6 EA)
26	2091160	PROPELLER W/WEDGE 2	62	2355410	SHRINK TUBE-3/8 ODx2	*116	2261713	WASHER-1/4 (6 EA)
27	2151726	WASHER-5/16 SS	64	2303434	SCREW-8-32 X 5/8 (3 EA)	*117	2263103	NUT NYLOK 1/4-20 MTG (6 EA)
28	2198400	ANODE-ZINC 3.25x3.625 LWR U	65	2090651	LEADWIRE (OGA 44"	*118	2301720	WASHER-MOUNTING RUBBER (6 EA)
29	2092600	PIN-DRIVE	65A	2307310	BEAD - FERRITE (CE MODELS ONLY)	■	2888460	SEAL & ORING KIT
30	2301545	COLLAR- LATCH PD/AP	66	2020700	TERMINAL RING (2 EA)			
31	2303434	SCREW- 8-32X5/8 MACH PHCR	67	2321310	STRAIN RELIEF- BRACKET PD/AP			
32	2303112	NUT 8-32 NYLOC SS	68	2323405	SCREW-1/4-20 X .68 SS			
33	2301937	EXTRUSION- BASE MACHINED	69	2306556	HOUSING- CENTER PD/AP WHIT			
34	2303932	MOTOR REST- RIGHT 3-5/8	70	2074080	BATTERY GAUGE - 12 VOLT			
35	2303937	MOTOR REST- LEFT 3-5/8	71	2316606	DECAL- BATT GAUGE H RT/AP			
36	2332104	SCREW 1/4-20X5/8 SS SELF TAP (4 EA)	72	2302935	STRAIN RELIEF-DR. HOUSING			
37	2771827	DRIVE HOUSING / LATCH HANDLE WHITE	73	2303944	SIDEPLATE (RIGHT) WHITE			
■	2862011	BUSHING/ OUTSHAFT KIT	74	2303949	SIDEPLATE(LEFT) WHITE			
		(INCLUDES 39-42)	75	2332104	SCREW-1/4-20 X .68 SS			
*39	2302010	DRIVE HOUSING OUTPUT SHAFT	76	2302516	CONTROL BOX WHT			
*40	2307304	BUSHING- INNER (2 EA)	77	2991280	COIL CORD W/STRAIN RELIEF 48, 54"			

* This item is part of an assembly. This item cannot be sold separately due to machining and /or assembly that is required.

P/N 2314951

REV. W

ECN 34117

10/12

Minn Kota accessories available for your motor.



OnBoard Chargers



Portable Chargers



Stabilizer Kits



Quick Release Brackets



Circuit Breakers



Anywhere. Anytime.

Visit our website at www.minnkotamotors.com