

P U N C H[®]

WIRED
REMOTE

PMX-1R



Serial Number: _____ Date of Purchase: _____

Introduction

Dear Customer,

Congratulations on your purchase of the world's finest brand of audio products. At Rockford Fosgate we are fanatics about musical reproduction at its best, and we are pleased you chose our product. Through years of engineering expertise, hand craftsmanship and critical testing procedures, we have created a wide range of products that reproduce music with all the clarity and richness you deserve.

For maximum performance we recommend you have your new Rockford Fosgate product installed by an Authorized Rockford Fosgate Dealer, as we provide specialized training through Rockford Technical Training Institute (RTTI). Please read your warranty and retain your receipt and original carton for possible future use.

Great product and competent installations are only a piece of the puzzle when it comes to your system. Make sure that your installer is using 100% authentic installation accessories from Rockford Fosgate in your installation. Rockford Fosgate has everything from RCA cables and speaker wire to power wire and battery connectors. Insist on it! After all, your new system deserves nothing but the best.

To add the finishing touch to your new Rockford Fosgate image, order your Rockford accessories, which include everything from T-shirts to hats.

Visit our web site for the latest information on all Rockford products;
www.rockfordfosgate.com

or, in the U.S. call 1-800-669-9899 or FAX 1-800-398-3985. For all other countries, call +001-480-967-3565 or FAX +001-480-966-3983.

Table of Contents

- 2 Introduction
- 3 Features/Mounting
 - Design Features
 - Mounting
- 7 Limited Warranty Information

If, after reading your manual, you still have questions regarding this product, we recommend that you see your Rockford Fosgate dealer. If you need further assistance, you can call us direct at 1-800-669-9899. Be sure to have your serial number, model number and date of purchase available when you call.

PRACTICE SAFE SOUND

Continuous exposure to sound pressure levels over 100dB may cause permanent hearing loss. High powered auto sound systems may produce sound pressure levels well over 130dB. Use common sense and practice safe sound.

Safety

This symbol with “WARNING” is intended to alert the user to the presence of important instructions. Failure to heed the instructions will result in severe injury or death.



This symbol with “CAUTION” is intended to alert the user to the presence of important instructions. Failure to heed the instructions can result in injury or unit damage.



To prevent injury and damage to the unit, please read and follow the instructions in this manual. We want you to enjoy this system, not get a headache.

If you feel unsure about installing this system yourself, have it installed by a qualified Rockford Fosgate technician.

Before installation, disconnect the battery negative (-) terminal to prevent damage to the unit, fire and/or possible injury.

FCC Compliance Statement

This equipment has been tested and found to comply with the limits for a Class B digital device, pursuant to part 15 of the FCC Rules. These limits are designed to provide more reasonable protection against harmful interference in a residential installation.

Operation is subjected to the following two conditions: (1) This device may not cause harmful interference, and (2) the device must accept any interference received, including interference that may cause undesired operation.

This equipment generates, uses, and can radiate radio frequency energy and, if not installed and used in accordance with the instructions, may cause harmful interference to radio communications. However, there is no guarantee that interference will not occur in a particular installation. If this equipment does cause harmful interference to radio or television reception, which can be determined by turning the equipment off and on, you are encouraged to try to correct the interference by one of the following measures:

- Reorient or relocate the receiving antenna.
- Increase the separation between the equipment and receiver.
- Connect the equipment into an outlet on a circuit different from that to which the receiver is connected.
- Consult the dealer or an experienced radio/TV technician for help

Contents

- Wired Remote
- Trim Bezel
- Mounting Plate
- U Bracket
- Screws
- Installation & Operation Manual

©2015 Rockford Corporation. All Rights Reserved. ROCKFORD FOSGATE, PUNCH® and associated logos where applicable are registered trademarks of Rockford Corporation in the United States and/or other countries. All other trademarks are the property of their respective owners. Specifications subject to change without notice.

Features/Mounting

Rotary Encoder

This knob is for adjusting main volume, zone volumes, menu navigation and setting adjustments.

REV / FWD button

Use this button to skip back and forward through channels or tracks with a short press. Long pressing will activate manual seek mode.

ISO 8846 / SAE J1171 Certified

Compatible with PMX-8BB, PMX-5 and PMX-2 source units. (3 Remote Limit, 100 ft Total Wired Distance)

MENU button

This button gives you access to the main settings of the unit by long pressing. Short pressing will give you access to the settings for the active source.

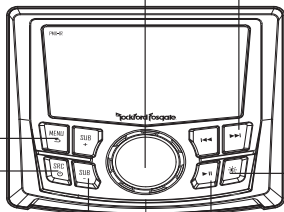

DIMMER button

Pressing this button will allow you to select between the two brightness values for the display.

SRC (Power) Button

This button allows you to switch between sources (short press) and power the unit ON and OFF (long press).

SUB Buttons

These buttons allow you to adjust the subwoofer output or rear line out UP or DOWN (0-20).

PLAY / PAUSE button

Press this button to play or pause your music. This button also acts as a MUTE when the source is in AUX & TUNER mode.

Mounting (Using Mounting Plate)

To mount the unit, you will need to find a flat surface with adequate clearance behind it that provides enough clearance for the unit and all its necessary wiring.

1. Once you have determined a mounting location, you will need to cut a circular hole 3" (77mm) in diameter.
2. After the hole is cut slide the unit and wiring through the hole.
3. Slide the mounting plate over the backside of the unit and secure with the supplied screws.
4. Press on the trim bezel to the front side of the unit.
5. Plug in all wiring harnesses and cables. Refer to the wiring diagram for wire harness connection types.

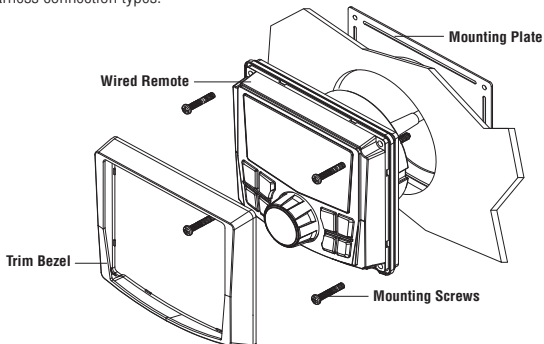

Mounting (Using U Bracket)

To mount the unit, you will need to find a flat surface with adequate clearance behind it that provides enough clearance for the unit and all its necessary wiring.

1. Once you have determined a mounting location, you will need to cut a circular hole 3" (77mm) in diameter.
2. After the hole is cut slide the unit and wiring through the hole.
3. Take the U bracket and slide over the two studs on the back of the unit. Tighten down with supplied nuts.
4. Press on the trim bezel to the front side of the unit.
5. Plug in all wiring harnesses and cables. Refer to the wiring diagram for wire harness connection types.

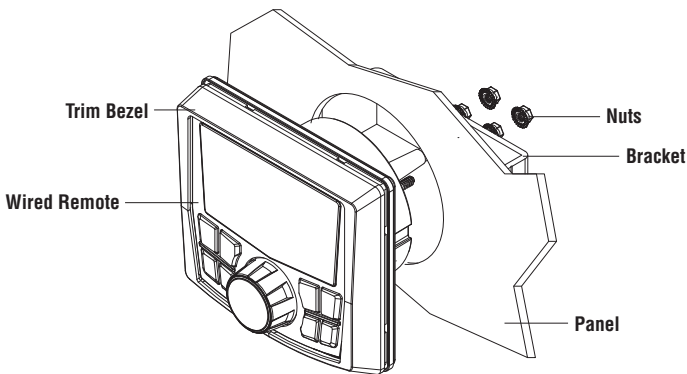

Warranty

Rockford Corporation offers a limited warranty on Rockford Fosgate products on the following terms:

Length of Warranty

- POWER Amplifiers – 2 Years
- BMW® Direct Fit Speakers – 2 Years
- Source Units – 1 Year
- All other products – 1 Year
- Any Factory Refurbished Product – 90 days (receipt required)

What is Covered

This warranty applies only to Rockford Fosgate products sold to consumers by Authorized Rockford Fosgate Dealers in the United States of America or its possessions. Product purchased by consumers from an Authorized Rockford Fosgate Dealer in another country are covered only by that country's Distributor and not by Rockford Corporation.

Who is Covered

This warranty covers only the original purchaser of Rockford product purchased from an Authorized Rockford Fosgate Dealer in the United States. In order to receive service, the purchaser must provide Rockford with a copy of the receipt stating the customer name, dealer name, product purchased and date of purchase. Products found to be defective during the warranty period will be repaired or replaced (with a product deemed to be equivalent) at Rockford's discretion.

What is Not Covered

1. Damage caused by accident, abuse, improper operations, water, theft, shipping.
2. Any cost or expense related to the removal or reinstallation of product.
3. Service performed by anyone other than Rockford or an Authorized Rockford Fosgate Service Center.
4. Any product which has had the serial number defaced, altered, or removed.
5. Subsequent damage to other components.
6. Any product purchased outside the U.S.
7. Any product not purchased from an Authorized Rockford Fosgate Dealer.

Limit on Implied Warranties

Any implied warranties including warranties of fitness for use and merchantability are limited in duration to the period of the express warranty set forth above. Some states do not allow limitations on the length of an implied warranty, so this limitation may not apply. No person is authorized to assume for Rockford Fosgate any other liability in connection with the sale of the product.

How to Obtain Service

Contact the Authorized Rockford Fosgate Dealer you purchased this product from. If you need further assistance, call 1-800-669-9899 for Rockford Customer Service. You must obtain an RA# (Return Authorization number) to return any product to Rockford Fosgate. You are responsible for shipment of product to Rockford.

EU Warranty

This product meets the current EU warranty requirements, see your Authorized dealer for details.

Installation assistance available at:

RFTECH

www.rockfordfosgate.com/rftech

Printed in China

1230-59186-01-C

060815

600 South Rockford Drive • Tempe, Arizona 85281 United States
Direct: (480) 967-3565 • Toll Free: (800) 669-9899

ROCKFORDFOSGATE.COM



FC