



USERS MANUAL / GEBRUIKERSHANDLEIDING / BETRIEBSANLEITUNG  
MANUEL UTILISATEUR / MANUAL DE UTILIZACION / INSTRUZIONI PER L'USO

# MASS COMBI

**12/2500-100; 24/2500-60; 48/2500-35; 48/5000-70**

SINE WAVE INVERTER/CHARGER COMBINATION  
WITH GENERATOR / MAINS SUPPORT



MASTERVOLT  
Snijdersbergweg 93,  
1105 AN Amsterdam  
The Netherlands  
Tel.: +31-20-3422100  
Fax.: +31-20-6971006  
www.mastervolt.com

ENGLISH:	PAGE 1
NEDERLANDS:	PAGINA 49
DEUTSCH:	SEITE 97
FRANÇAIS:	PAGINA 145
CASTELLANO:	PÁGINA 193
ITALIANO:	PÁGINA 241

Copyright © 2010 Mastervolt , v 2.2 May 2010

## CONTENTS:

v 2.2 May 2010

<b>1</b>	<b>GENERAL INFORMATION.....</b>	<b>4</b>
1.1	Use of this manual.....	4
1.2	Guarantee specifications.....	4
1.3	Validity of this manual.....	4
1.4	Quality.....	4
1.5	Liability.....	4
1.6	Identification label.....	4
1.7	Changes to the MASS COMBI.....	4
<b>2</b>	<b>SAFETY GUIDELINES AND MEASURES.....</b>	<b>5</b>
2.1	Warnings and symbols.....	5
2.2	Use for intended purpose.....	5
2.3	Organizational measures.....	5
2.4	Maintenance & repair.....	5
2.5	General safety and installation precautions.....	5
2.6	Warning regarding life support applications.....	6
2.7	Warning regarding the use of batteries.....	6
<b>3</b>	<b>HOW IT WORKS.....</b>	<b>7</b>
3.1	The battery charger.....	7
3.1.1	Three step Plus charge system.....	7
3.1.2	Temperature compensated charging.....	8
3.1.3	Connection of a second battery.....	8
3.2	The inverter.....	8
3.2.1	General.....	8
3.2.2	Energy saving mode (selectable).....	8
3.3	Operation modes.....	9
3.3.1	Basic operation.....	9
3.3.2	The transfer switch.....	9
3.3.3	Power sharing function (selectable).....	9
3.3.4	Generator / mains support function (selectable).....	10
3.3.5	Power support function (selectable).....	11
3.3.6	Summary of the AC operation modes.....	11
3.4	Parallel operation.....	12
3.5	Remote monitoring.....	12
3.5.1	Remote panel ICC.....	12
3.5.2	Remote panel APC.....	13
3.5.3	Masterlink MICC panel.....	13
3.5.4	MasterBus-serial interface.....	13
3.6	Alarm contacts.....	13
<b>4</b>	<b>OPERATION.....</b>	<b>14</b>
4.1	Indicators.....	14
4.2	Switching On and Off.....	14
4.2.1	Switching on.....	14
4.2.2	Switching Off.....	15
4.2.3	Switching Ch. (Charger only).....	15
4.3	Protections.....	15
4.3.1	Transfer switch overload protection.....	15
4.3.2	Output overload or short circuit.....	16
4.3.3	Overheating.....	16
4.3.4	Under and over voltage.....	16
4.4	Maintenance.....	16
4.5	Problem solving.....	16

<b>5</b>	<b>INSTALLATION</b> .....	<b>17</b>
5.1	Unpacking .....	17
5.2	Environment .....	17
5.3	Wiring .....	17
5.3.1	AC-wiring .....	17
5.3.2	DC wiring .....	18
5.3.3	AC safety grounding .....	18
5.4	Things you need .....	19
5.5	Removal of the front panel .....	20
5.6	Overview connection compartment .....	21
5.7	Mounting of the cabinet .....	23
5.8	Wiring instructions .....	23
5.8.1	Wiring instructions for one Mass Combi (stand alone operation) .....	25
5.8.2	Wiring instructions for two Mass Combi's (parallel operation) .....	27
5.8.3	Alarm contacts .....	28
5.9	Settings .....	28
<b>6</b>	<b>SETTINGS</b> .....	<b>29</b>
6.1	DIP Switch A .....	29
6.1.1	Parallel mode .....	29
6.1.2	Output frequency inverter .....	29
6.1.3	Energy saving mode .....	30
6.1.4	Battery type .....	30
6.1.5	Ground relay .....	30
6.2	DIP Switch B .....	31
6.2.1	Power sharing function .....	31
6.2.2	Power Support Function .....	31
6.2.3	Generator / mains support function .....	31
6.2.4	Setting for Power Quality at incoming AC .....	31
6.2.5	Combi/inverter control .....	32
6.2.6	Equalize mode .....	32
<b>7</b>	<b>START-UP AFTER INSTALLATION</b> .....	<b>33</b>
7.1	Commissioning .....	33
7.2	Decommissioning .....	33
<b>8</b>	<b>MASTERBUS</b> .....	<b>34</b>
8.1	What is MasterBus? .....	34
8.2	How to set up a MasterBus network .....	34
8.3	MasterBus: Monitoring and Configuration of the Mass Combi .....	35
8.3.1	Monitoring .....	35
8.3.2	Configuration .....	36
8.3.3	List of list of events sources .....	37
8.3.4	List of list of event commands .....	38
<b>9</b>	<b>TROUBLE SHOOTING</b> .....	<b>39</b>
9.1	Fault indicators .....	39
9.2	Software version .....	41
<b>10</b>	<b>TECHNICAL DATA</b> .....	<b>42</b>
10.1	Specifications inverter .....	42
10.2	Specifications charger .....	43
10.3	Miscellaneous .....	44
10.4	Characteristics .....	45
<b>11</b>	<b>ORDERING INFORMATION</b> .....	<b>47</b>
<b>12</b>	<b>EC DECLARATION OF CONFORMITY</b> .....	<b>48</b>

# 1 GENERAL INFORMATION

## 1.1 USE OF THIS MANUAL

This manual serves as a guideline for the safe and effective operation, maintenance and possible correction of minor malfunctions of the Mass Combi.

It is therefore obligatory that every person who works on or with the Mass Combi must be completely familiar with the contents of this manual, and that he/she carefully follows the instructions contained herein.

Installation of, and work on the Mass Combi, may be carried out only by qualified, authorised and trained personnel, consistent with the locally applicable standards and taking into consideration the safety guidelines and measures (chapter 2 of this manual).

Keep this manual at a secure place!

The English version has 48 pages.

## 1.2 GUARANTEE SPECIFICATIONS

Mastervolt guarantees that this unit has been built according to the legally applicable standards and specifications. Should work take place, which is not in accordance with the guidelines, instructions and specifications contained in this users manual, then damage may occur and/or the unit may not fulfil its specifications. All of these matters may mean that the guarantee becomes invalid.

The guarantee is limited to the costs of repair and/or replacement of the product. Costs for installation labor or shipping of the defective parts are not covered by this guarantee.

## 1.3 VALIDITY OF THIS MANUAL

Copyright © 2010 Mastervolt. All rights reserved.

Reproduction, transfer, distribution or storage of part or all of the contents in this document in any form without the prior written permission of Mastervolt is prohibited.

All of the specifications, provisions and instructions contained in this manual apply solely to standard versions of the Mass Combi delivered by Mastervolt.

This manual is only valid for the following models with apparatus version "M" and higher (see section 1.6):

Description	Part number
Mass Combi 12/2500-100 / 230V	36012505
Mass Combi 24/2500-60 / 230V	36022505
Mass Combi 48/2500-35 / 230V	36042505
Mass Combi 48/5000-70 / 230V	36045005

For other models see other manuals available on our website: [www.mastervolt.com](http://www.mastervolt.com)

## 1.4 QUALITY

During their production and prior to their delivery, all of our units are tested and inspected. The standard guarantee period is two years after date of purchase.

## 1.5 LIABILITY

Mastervolt can accept no liability for:

- consequential damage due to use of the Mass Combi;
- possible errors in the manuals and the results thereof.

## 1.6 IDENTIFICATION LABEL

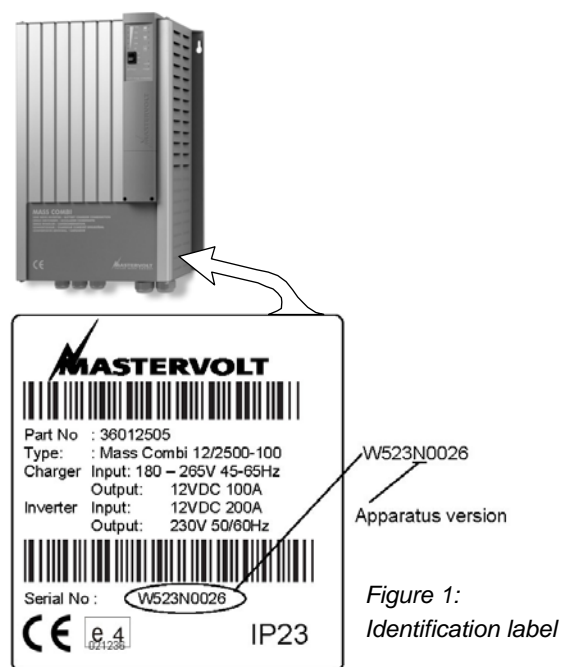

The identification label is located at the right-hand side of the Mass Combi. (see figure 1) Important technical information required for service, maintenance & secondary delivery of parts can be derived from the identification label.



### CAUTION!

Never remove the identification label.

## 1.7 CHANGES TO THE MASS COMBI

Changes to the Mass Combi may be carried out only after obtaining the written permission of Mastervolt. This is not applicable for DIP-switches (see chapter 6) which are used for making user settings.

## 2 SAFETY GUIDELINES AND MEASURES

### 2.1 WARNINGS AND SYMBOLS

Safety instructions and warnings are marked in this manual by the following pictograms:



A procedure, circumstance, etc which deserves extra attention.



#### CAUTION!

Special data, restrictions and rules with regard to preventing damage.



#### WARNING

A WARNING refers to possible injury to the user or significant material damage to the charger if the user does not (carefully) follow the procedures.

### 2.2 USE FOR INTENDED PURPOSE

- 1 The Mass Combi is constructed as per the applicable safety-technical guidelines.
- 2 Use the Mass Combi only:
  - for the charging of lead acid batteries and the supply of users attached to these batteries, in permanent systems;
  - for the conversion of a DC voltage from a battery to an AC voltage.
  - connected to a dedicated double pole circuit breaker and earth leakage switch.
  - with a fuse, protecting the wiring between Mass Combi and battery;
  - in a technical correct condition;
  - in a closed, well-ventilated room, protected against rain, moist, dust and condensation;
  - observing the instructions in the users manual.



#### WARNING

Never use the Mass Combi in situations where there is danger of gas or dust explosion or potentially flammable products!

- 3 Use of the Mass Combi other than mentioned in point 2 is not considered to be consistent with the intended purpose. Mastervolt is not liable for any damage resulting from the above.

### 2.3 ORGANIZATIONAL MEASURES

The user must always:

- have access to the user's manual;
- be familiar with the contents of this manual. This applies in particular to chapter 2, Safety Guidelines and Measures.

### 2.4 MAINTENANCE & REPAIR

- 1 If the Mass Combi is switched off during maintenance and/or repair activities, it should be secured against unexpected and unintentional switching on:
  - remove the AC supply
  - remove the connection to the batteries
  - be sure that third parties cannot reverse the measures taken.
- 2 If maintenance and repairs are required, use only original spare parts.

### 2.5 GENERAL SAFETY AND INSTALLATION PRECAUTIONS

- Do not expose the Mass Combi to rain, snow, spray, moisture, excessive pollution and condensing circumstances. To reduce risk of fire hazard, do not cover or obstruct the ventilation openings. Do not install the Mass Combi in a non-ventilated area, overheating may result.
- The Mass Combi must be provided with an equipment-grounding conductor to the AC-input ground terminal. Grounding and all other wiring must comply with local codes and ordinances.
- In case of fire, you must use the fire extinguisher which is appropriate for electrical equipment.
- Short circuiting or reversing polarity will lead to serious damage to batteries, Mass Combi and the wiring. Fuses between the batteries and the Mass Combi can not prevent damage caused by reversed polarity and the warranty will be void.
- Protect the DC wiring with a fuse, according to the guidelines in this manual.
- Connection and protection must be done in accordance with local standards.
- Do not work on the Mass Combi or system if it is still connected to a power source. Only allow changes in your electrical system to be carried out by qualified electricians.
- Check the wiring and connections at least once a year. Defects such as loose connections, burned cables etc. must be corrected immediately.

- Do not touch the equipment when wet or if your hands are clammy.
- Not only the batteries, but the Mass Combi as well can become a projectile if your transport is involved in an accident! Ensure adequate and secure mounting and always use suitable handling equipment for transportation.
- Except for the connection compartment, see section 5.5, the cabinet of the Mass Combi must not be opened. There are no serviceable parts inside the cabinet. Only qualified, authorized and trained electrician installers are authorized to open the connection compartment.

## **2.6 WARNING REGARDING LIFE SUPPORT APPLICATIONS**

The Mass Combi products are not sold for applications in any medical equipment intended for use as a component of any life support system unless a specific written agreement pertaining to such intended use is executed between the manufacturer and Mastervolt. Such agreement will require the equipment manufacturer either to contract additional reliability testing of the Mass Combi parts and/or to commit to undertake such testing as a part of the manufacturing process. In addition the manufacturer must agree to indemnify and not hold Mastervolt responsible for any claims arising from the use of the Mass Combi parts in the life support equipment.

## **2.7 WARNING REGARDING THE USE OF BATTERIES.**

Excessive battery discharge and/or high charging voltages can cause serious damage to batteries. Do not exceed the recommended limits of discharge level of your batteries. Avoid short circuiting batteries, as this may result in explosion and fire hazard. Installation of the batteries and adjustments of the Mass Combi should only be undertaken by authorised personnel!

### 3 HOW IT WORKS

This chapter describes the various applications of the Mass Combi series from Mastervolt.

The Mastervolt Mass Combi is a battery charger, a powerful sine wave inverter and an AC transfer system in one compact enclosure. The three-step Plus charging method guarantees that the batteries are always charged 100%. The pure sine wave inverter assures that the AC output voltage is perfectly reliable even when limited external AC power is available. External AC power can be supplied by a public grid or a generator. DC power can be delivered by charged batteries.

#### 3.1 THE BATTERY CHARGER

The built-in battery charger is electronically controlled. It is designed for optimal recharging of both wet cell, gel cell and AGM deep cycle batteries. Battery charging is accomplished in three automatic stages: BULK, ABSORPTION and FLOAT. With an external AC source connected, the Mass Combi charger also serves the functions of an AC to DC converter to supply DC loads which are connected to the battery. Simple, automatic operation is made possible by the microprocessor that is the brain of the inverter/charger combination. In most cases, the unit is left on and no attention or maintenance is required.

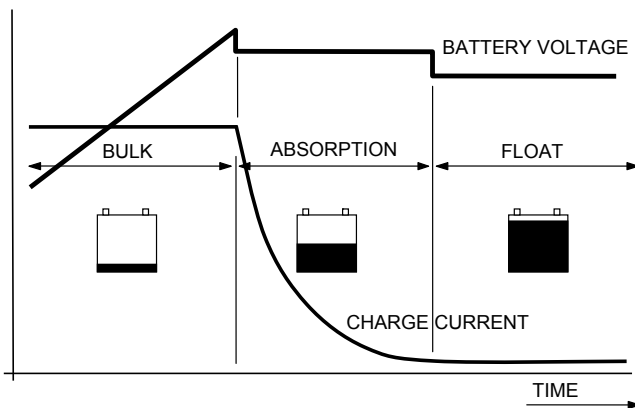

Figure 2:  
Three step charge system

#### 3.1.1 Three step Plus charge system

See figure 2. The first step of the three step Plus charge system is the BULK phase, in which the output current of the charger is 100%, and the greater part of the capacity of the battery is rapidly charged. The current charges the batteries and gradually the voltage rises to the absorption voltage of 14.4, 28.8 or 57.6 V (12, 24 resp. 48V models) @ 25°C / 77°F.

The duration of this phase depends on the ration of battery to charger capacity, and naturally also on the degree to which the batteries were discharged to begin with.

The bulk phase is followed by the absorption phase. Absorption charging starts when the voltage on the batteries has reached 14.4, 28.8 or 57.6 V (12, 24 resp. 48V models) @ 25°C / 77°F, and ends when the battery is completely full. Battery voltage remains constant at 14.25, 28.5, 57 V (12, 24 resp. 48V models) @ 25°C / 77°F throughout this stage, and the charge current depends on the degree to which the battery was initially discharged, the battery type, the ambient temperature, and so on. With a wet cell battery this stage lasts some four hours, with gel and AGM around three. Once the battery is 100% full, the Mastervolt charger automatically switches over to the float phase.

During the float phase the Mass Combi switches to 13.25, 26.5 or 63 V (12, 24 resp. 48V models) @ 25°C / 77°F and stabilises this voltage to maintain the batteries in an optimum condition. Connected DC-loads are powered directly by the charger. If the load is higher than charger capacity, the required additional power comes from the battery, which will be progressively discharged until the charger automatically switches back to the bulk phase. Once consumption decreases, the charger goes back to normal operation of the three-step charge system.

As the Mass Combi is equipped with a three-step Plus charge system, the batteries can also remain connected to the Mass Combi in winter. One hour every 12 days the charger automatically switches to absorption to keep the battery running properly and prolong its life span. The three-step Plus charge system is also safe for all the connected equipment.

See also section 10.4 for detailed characteristics of the three step Plus charge system.

### 3.1.2 Temperature compensated charging

The Mass Combi is delivered with a battery temperature sensor. By installing this battery temperature sensor the charge voltages are automatically adapted for deviating temperatures.

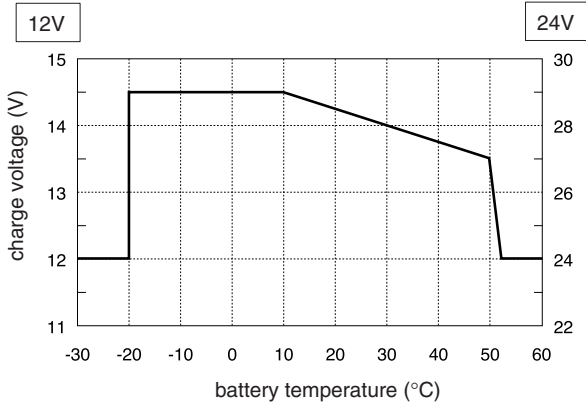

Figure 3:  
Temperature compensated charging

See figure 3. When the battery temperature is low, the charge voltage increases. On the other hand, when the battery temperature is high, the charge voltage is decreased. Over charge and gassing are prevented this way. This will extend the life of your batteries.

See section 5.8 to connect the battery temperature sensor.

### 3.1.3 Connection of a second battery

The Mass Combi is equipped with second charge output which can be used to give a maintenance charge to a small battery set like a starter battery Maximum output current: 5 Amps.

Output voltage: same as the main charger.

See section 5.8 for connection.

## 3.2 THE INVERTER

### 3.2.1 General

The inverter provides voltage and frequency regulated AC power from a battery bank. Fast acting electronic circuits protect the inverter against extreme overloads, low and high battery voltage and overheating of the inverter.

Considerable momentary surge power is available for starting-up electric motors. High efficiency insures long battery usage between recharges. A built in energy saving feature can reduce battery power consumption when the inverter is unloaded.

### 3.2.2 Energy saving mode (selectable)

In the inverter mode the Mass Combi has a built-in automatic energy saving feature that reduces battery power consumption when no load is present on the "SHORT BREAK" output. Response from idle is instant. In most cases the operation is not noticeable. Four modes can be set by means of DIP-switches, see chapter 6.

The inverter of the Mass Combi can operate in one of the following modes (table below):

Mode	Explanation
High power	The energy saving mode is switched off. The inverter is fully operating and the output voltage is 230V AC. This is the default setting.
Idle 40VA	With a connected load less than 40VA or 150VA, the inverter reduces the output voltage to almost zero. The Mass Combi scans the "SHORT BREAK" outlet with pulses of 230V every 2½ seconds. When it detects a load that is larger than 40VA or 150VA, it switches on the inverter automatically. Small loads such as clocks in VCR's or micro waves are most likely not to work on this mode.
Idle 150VA	
Economy mode	The inverter reduces the output voltage to 208VAC if the connected load drops below 250VA. The output voltage will return to 230VAC if the connected load rises above 250 VA. Small loads as clocks in VCR's and micro waves will perform equal whether the inverter is running in the economy state or is on. The energy saving from your batteries is approximately 10%.

For detailed specifications see section 10.1 "DC no load power consumption"

Table 1: Mass Combi energy saving modes



### 3.3 OPERATION MODES

The Mass Combi is not just a combination of an inverter and a battery charger. It has many additional features which can be used to increase the total available AC power, even when external AC power is limited.

#### 3.3.1 Basic operation

When there is no external AC power available, the inverter of the Mass Combi provides AC power on the "SHORT BREAK" output from the batteries. There is no AC power available on the "POWER" output. Now the Mass Combi is in "Inverter mode". See figure 4.

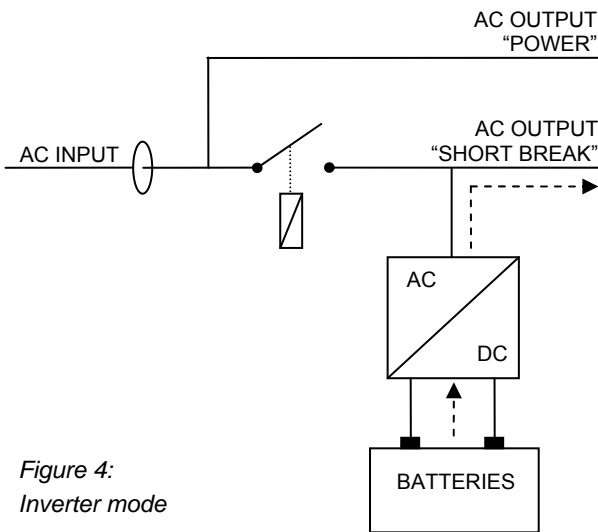

Figure 4:  
Inverter mode

When external AC power comes available, the transfer relay switches on. See figure 5. Both outputs as well as the battery charger are supplied by the external AC power. The batteries are recharged now. Now the Mass Combi is in "Charger mode".

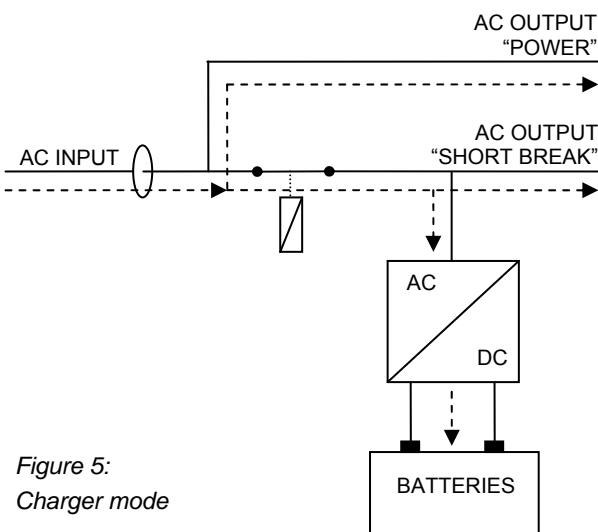

Figure 5:  
Charger mode

#### 3.3.2 The transfer switch

The Mass Combi has two AC-outputs available;

- SHORT BREAK output. The "SHORT BREAK" output switches between the AC-input and the output of the inverter. The AC input has the highest priority. In principle, AC-power is always available on this output. However during a switchover the loads connected to this output are not supplied with AC-power for a very short period of time (short break). It is the ideal output for loads that need AC-power permanently like personal computers, interior lighting and the refrigerator.
- POWER output. This output is always internally connected to the AC-input. It is therefore only available when an external AC-source like shore power, a generator or an outlet is present. Larger loads like a hot water boiler, electric cooking appliance or washing machine should be connected to this output

#### 3.3.3 Power sharing function (selectable)

If the available power at the AC-input is limited, and the load connected to the AC output increases, the external AC circuit breaker may trip if nothing is done. To avoid this, the Mass Combi can automatically reduce the battery charger output, and thus the AC power consumption. This *Power sharing* feature constantly senses the incoming AC current which is used to supply both the battery charger and the appliances connected to the AC outputs.

The *Power Sharing level* should be set to match the value of the external circuit breaker, which protects the incoming AC power. For instance, when the external AC power is limited by a 6A fuse, the *Power Sharing level* must be set to 6A.

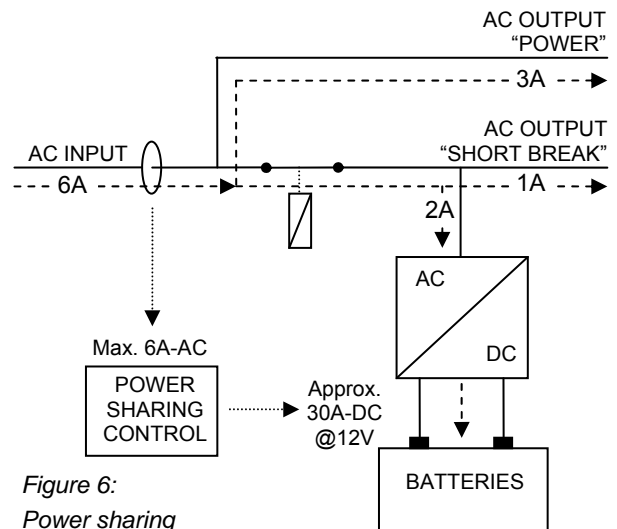

Figure 6:  
Power sharing

See figure 6.

Here the *Power Sharing level* is set to a 6 Amps while the AC outputs consume a total of  $1 + 3 = 4$  Amps. This means that only  $6 - 4 = 2$  Amps is left over for charging. With 12V batteries this will result in a maximum charge current of approx. 30A DC

Although the *Power Sharing level* can be set by means of the DIP-switches locally on the Mass Combi (see section 6.2.1), we recommend the use of an optional remote control panel, like the Remote APC or Masterlink MICC. With this remote panel you can select the available shore current (fuse) of each marina or camping site in a very easy way.

When the total connected AC load reaches the level of the Power Sharing setting (6A), there will be no power left over to charge the battery. This means that the charge current of the Mass Combi will be reduced to 0A. See figure 7.

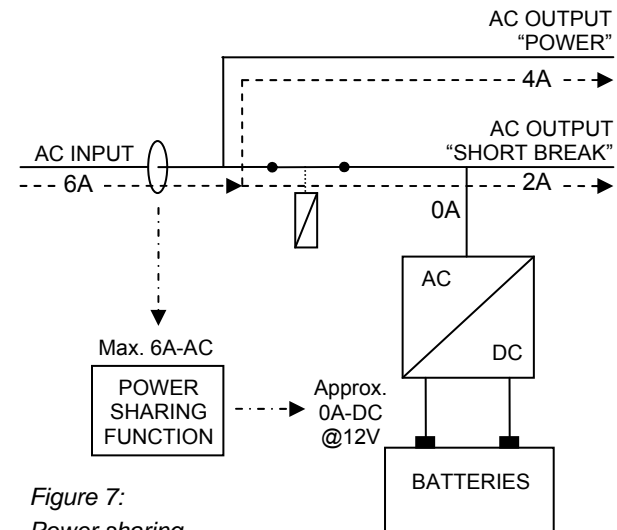

Figure 7:  
Power sharing

### 3.3.4 Generator / mains support function (selectable)

If the demand for AC power still increases, the external AC circuit breaker may still trip if nothing is done. This problem can be solved by the *Generator / mains support function*. If the total demand for energy exceeds the maximum external power supply, energy can be added to the AC outputs “POWER” and “SHORT BREAK” by means of the inverter. This appliance can be automatically connected in parallel with the external power supply.

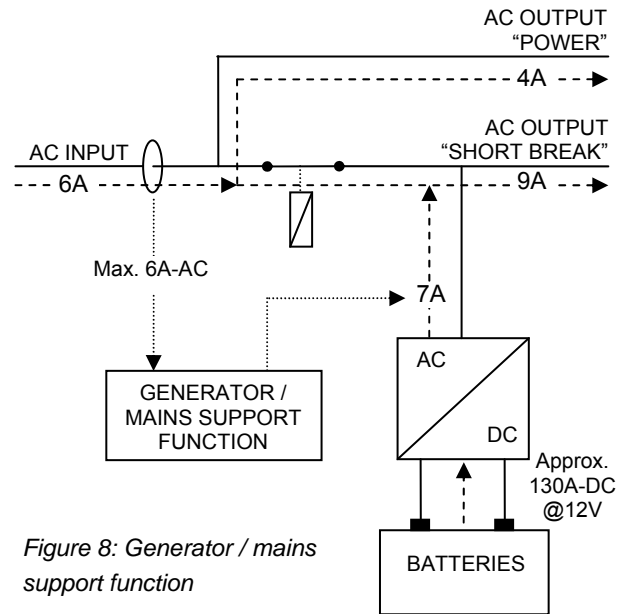

Figure 8: Generator / mains support function

See figure 8

Here the AC-input is still limited to 6 Amps. This is not enough to supply the total load ( $4 + 9A = 13A$ ) connected to the AC outputs.

When the *Generator / mains support function* is enabled, the inverter will supply the remaining  $13 - 6 = 7A$ . This means that the restricted amount of external AC power will be compensated by energy which is stored in the batteries.

Later, when the AC load has dropped below the setting of the Power sharing function again, the battery charger of the Mass Combi will commence to recharge the batteries. For safety reasons the transfer relay is immediately switched off when incoming AC power fails in operation so that there will never be a high voltage on the shore cable inlet when it is not connected.

### 3.3.5 Power support function (selectable)

As explained above, when the *Generator / mains support function* is enabled, the inverter will operate in parallel with the external AC power source. This means that energy from the batteries is added to the AC-output only. Under no circumstance AC power from the inverter can be fed back into the AC grid. Please mind that several countries maintain different regulations with regard to AC-sources operating in parallel with the AC-grid. This may mean that in some situations the use of the *Generator / mains support function* is not allowed. Please acquaint yourself with local regulations on this issue. Never use the *Generator / mains support function* if this is not allowed!

Even if the use of the *Generator / mains support function* is not allowed, it is still possible to supply more energy than the external AC sourced can deliver. This can be achieved by using the *Power support function*.

See figure 9

The AC-input is still limited to 6 Amps. This is not enough to supply the total load (4 + 9A = 13A) connected to the AC outputs.

Now when the *Power support function* is enabled, the transfer relay will open. When opened, the external power source will deliver 4A to supply the load connected to the "POWER" output only, while the inverter will deliver 9 Amps for the load connected to the "SHORT BREAK" output.

Please note that if the power consumption of the "POWER" output exceeds the setting of the power support function, the external AC fuse will still trip

If the total current from the "POWER"-output and "SHORT BREAK"-output is less then the *Power support* setting during approx. 10 minutes, the Mass Combi connects the "SHORT BREAK" output back to the AC-input again. The charger commences charging again when the load reduces further and the total current drops below the *Power sharing* setting.



**NOTE!** You can either choose the *Generator / mains support function* or the *Power support function*, not both simultaneously.

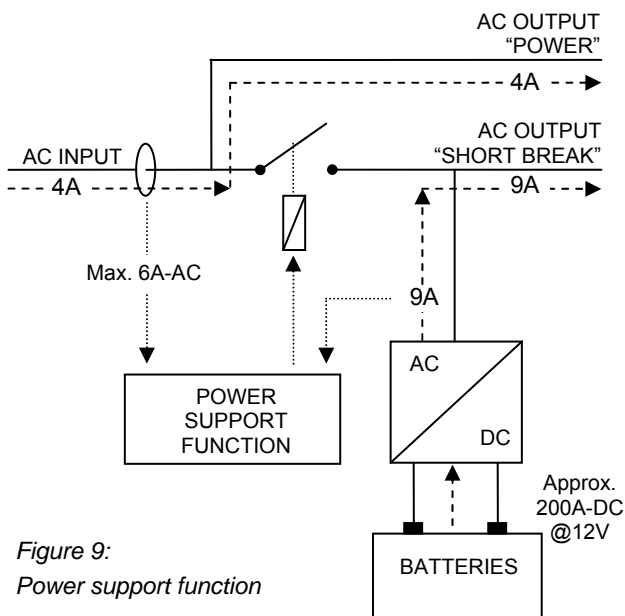

Figure 9:  
Power support function

### 3.3.6 Summary of the AC operation modes

Function	DIP-switch*	What is it used for?	How is this achieved?
Power Sharing	B-SW3	To protect the incoming AC from overload	By reducing the charge current and thus the AC input current.
Generator / Mains support	B-SW5	To deliver more AC power than available from the incoming AC.	The AC output of the inverter is connected in parallel with the incoming AC. This means that energy from the batteries is added to the incoming AC.
Power support	B-SW4	To deliver more AC power than available from the incoming AC.	The load which is connected to the "POWER"-output is supplied by the incoming AC, while the SHORT BREAK output is connected to the output of the inverter.

Table 6: Overview of the AC operation modes

\* see chapter 6 for adjustment of the DIP-switches

### 3.4 PARALLEL OPERATION

If 2500W of inverter power is not sufficient, yet another identical Mass Combi can be connected in parallel to double both the inverter power and the charge power. With two units in parallel the total inverter power conversion will be equally divided between the two units. To achieve this, one of the units must be configured by means of a DIP-switch setting as 'master' and the other as 'slave'. See figure 10. Once the configuration is established the master tells the slave apparatus what to do. This communication is done by the use of a modular communication cable between the two units.



**NOTE!** : Only two units of the Mass Combi 12/2500-100, Mass Combi 24/2500-60 or the Mass Combi 48/2500-35 can be connected in parallel. Parallel operation of two units of the Mass Combi 48/5000-70 is not possible.

See section 5.8.2 for connection and settings.

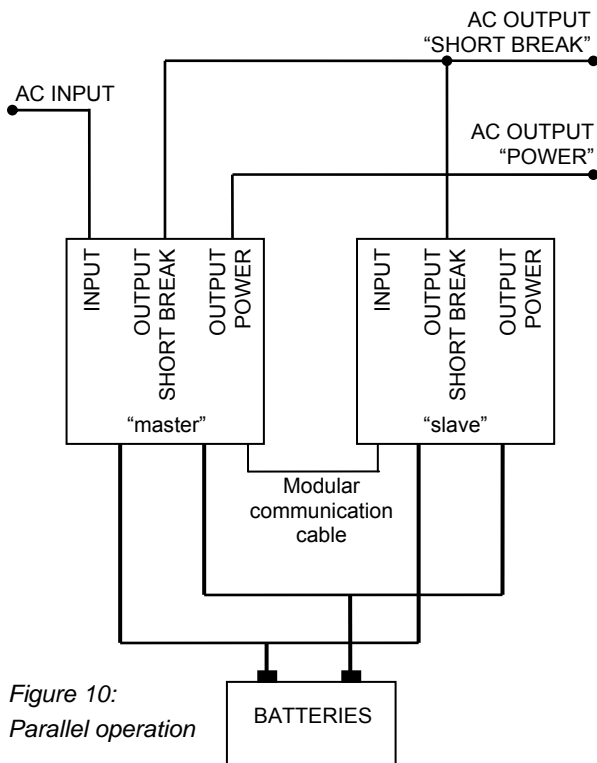

Figure 10: Parallel operation

### 3.5 REMOTE MONITORING

Mastervolt offers several possibilities for remote monitoring and control of the Mass Combi.

There are three remote panels available for the Mass Combi. The *Inverter Charger Control (ICC)* panel and the *AC Power Control (APC)* panel are specially designed for the Mass Combi. The *Mass Inverter Charger Control (MICC)* is a universal panel.

The remote panels are connected to the Mass Combi via a modular communication cable with two RJ 12 connectors. The maximum length of communication cable should not exceed 15m/49ft. See chapter 11 for ordering information.

The Mass Combi can also be connected to the *MasterBus* network. Therefore a *MasterBus serial interface* is included with the delivery.

Note that it is not possible to connect all panels and the serial interface at the same time. You should choose one of the following options:

- No remote monitoring at all
- Remote panel ICC only
- Remote panels APC and ICC
- Masterlink MICC panel only
- MasterBus serial interface only
- MasterBus serial interface and Remote panel ICC

#### 3.5.1 Remote panel ICC



Figure 11: Remote panel ICC

The ICC panel provides the same functions as the user panel on the Mass Combi. However, with this remote panel you have the convenience to operate the Mass Combi remotely. See chapter 11 for ordering information)

### 3.5.2 Remote panel APC



Figure 12: Remote panel APC

The APC panel has extended functions such as setting remotely the Power sharing value and monitoring your “AC-load”. This APC remote panel is optional (see chapter 11 for ordering information).

### 3.5.3 Masterlink MICC panel

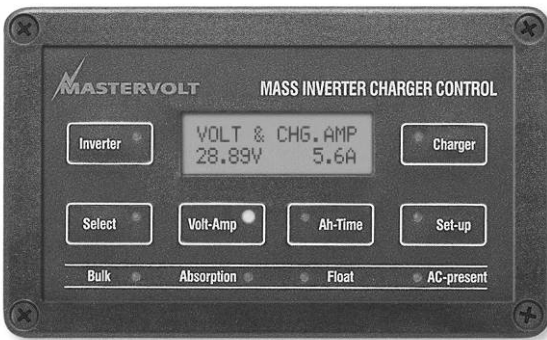

Figure 13: Masterlink MICC panel

The Masterlink MICC panel (art. no 70403105) is a digital remote panel that has additional features compared to the ICC and APC panel. This sophisticated panel is not only a remote control panel to switch on and off your Mass Combi but also a battery consumption meter for read-out of the exact state-of-charge of your battery by means of a shunt. (included with the delivery of the Masterlink MICC) When the battery is reaching a low voltage set point or a low state-of-charge an alarm can be raised. This can be used to start up the generator.

The information provided includes reading voltage, current, consumed Ah, time remaining and remaining capacity as a percentage of the maximum available battery capacity. A well-lit LCD screen also displays direct online data or historical information. A protective back box, easy to install, is included as standard for protecting the electronic components. This panel is suitable for MasterVision, Mastervolt’s modular switchboard system.

### 3.5.4 MasterBus-serial interface



Figure 14: MasterBus-serial interface

The MasterBus – serial interface is standard included with the delivery of the Mass Combi 12/2500-100, 24/2500-60, 48/2500-35 and 48/5000-70. With this interface you can connect your Mass Combi to the MasterBus network: a fully decentralized data network for communication between the different Mastervolt system devices such as the inverter, battery charger, generator, batteries and many more. This enables monitoring and configuration with a MasterView display or the MasterAdjust software. See chapter 8 for details.

### 3.6 ALARM CONTACTS

The Mass Combi is equipped with an integrated alarm function. External equipment can be controlled by the potential free contacts of this alarm (see 5.8.3). The maximum switch current of the relay is 1A. By default the relay will be activated when the DC-voltage is out of range, after a delay of 30 seconds. See table below. Other functions can be programmed by means of MasterAdjust software via the MasterBus – serial interface

Nominal voltage:	12V	24V	48V
Under voltage ON:	10.0V	20.0V	40.0V
Under voltage OFF:	11.0V	22.0V	44.0V
Over voltage ON:	16.0V	32.0V	63.0V
Over voltage OFF:	15.5V	31.0V	62.0V

Table 3

## 4 OPERATION

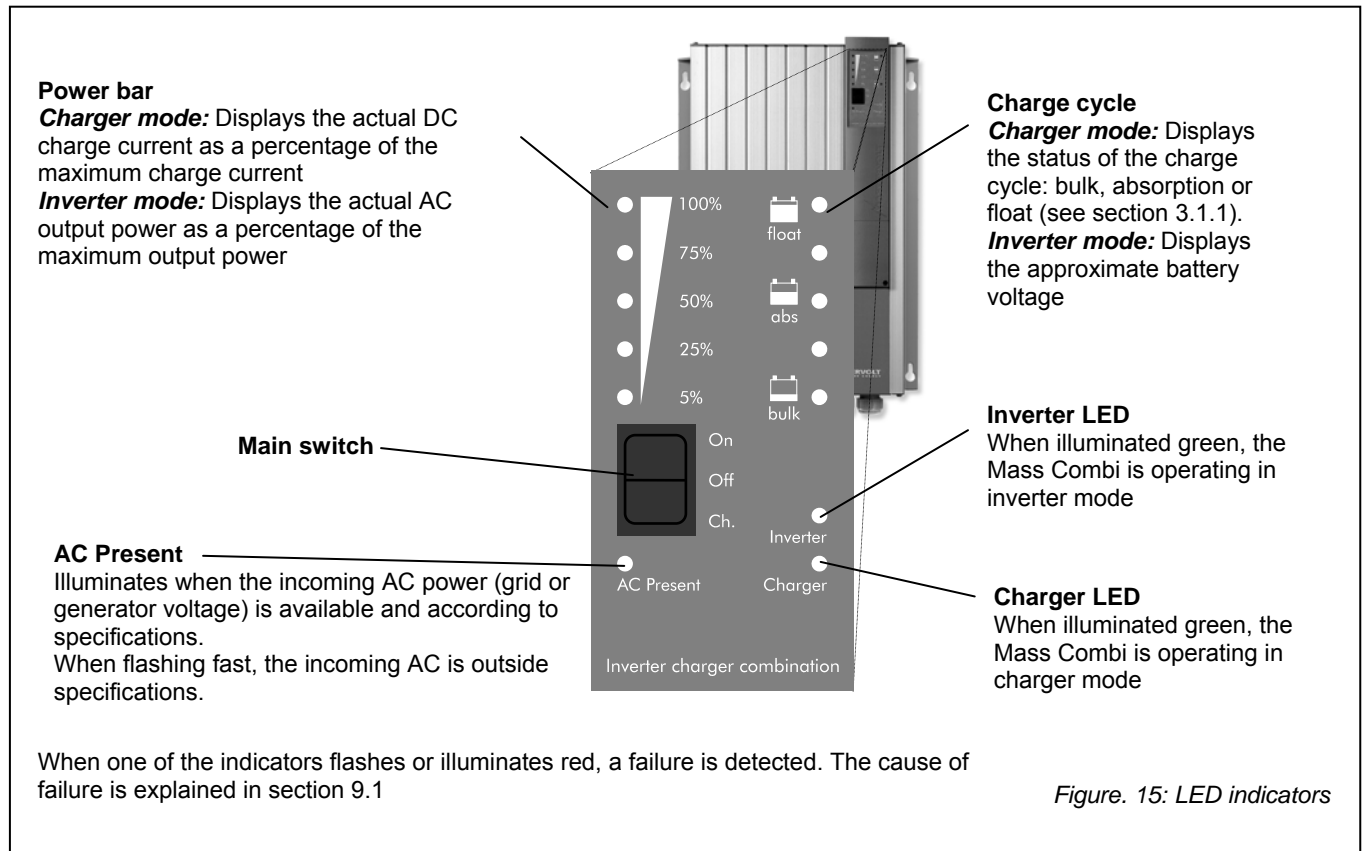

The Mass Combi is a fully automatic inverter / charger system. Under normal circumstances there is no need for adjustment or operation besides switching on and off.



If two Mass Combis are installed in parallel, the slave unit will only operate properly after the master unit was switched on first.



### WARNING

Never disconnect any of the wiring during operation of the Mass Combi

### 4.1 INDICATORS

See figure 15. The operation of the Mass Combi is displayed by means of LED indicators at the front side of the housing. If the Mass Combi is activated and as long as none of the red indicators are illuminated, no failure is detected and the unit is operating normally.

### 4.2 SWITCHING ON AND OFF

The only control on the Mass Combi itself is the main switch (see figure 15) on the front of the unit. This switch controls On, Off and Ch. (Charger only)

#### 4.2.1 Switching on

The Mass Combi can be activated by switching the main switch to the "ON" position.

If you use a remote control panel, press the on/off button on the remote control panel.

After switching on expect a three till five second delay before the unit is activated. The LED-indicators will blink several times, indicating the installed software version (see section 9.2 for explanation).

If AC power is available on the AC input and within the specified limits, the Mass Combi will switch to Charger Mode and will commence to charge the batteries. At the same time the internal transfer relay will pass the AC power to the AC output "SHORT BREAK".

If the AC power from the external AC-source is unavailable or outside the specified limits, the unit will come on as an inverter. Inverter overload protection, built-in idle mode circuitry, transfer switching, power sharing and battery charger regulation will all function automatically.

### 4.2.2 Switching Off

Move the main switch to the “Off” position to switch off the Mass Combi. If you use a remote control panel, press the on/off button on the remote control panel. The Mass Combi stops and all the indicators go off. The “Short” break output is disconnected and will become powerless.



#### WARNING

Switching off the Mass Combi with the main switch on the front of the cabinet does not cut off the connection to the batteries or the AC-source. Therefore the “POWER” output is still active



NOTE! When the main switch is in the “Off”-position, it overrides the remote control panel. In this off state it is not possible to start the Mass Combi remotely.

### 4.2.3 Switching Ch. (Charger only)

When the main switch is set to the “Ch.”-position, the Mass Combi is only able to work as a charger. This means that the inverter mode is disabled. This setting is useful if you want to keep your batteries charged and maintained in case you are away i.e. in the winter time. Now your batteries are spared when the incoming AC-source fails in operation.

If you use the remote panel ICC or MICC you can still switch-on/off the charger remotely, even if the incoming AC-source is not available. If the AC-source is available and the Mass Combi is operating in the charger mode, the user panel shows the actual status of the system.

## 4.3 PROTECTIONS

The Mass Combi is protected against overload, short circuit, over heating and under and over voltage. The user can detect failures from the local user panel or from one of the (optional) remote control panels by means of the indicators.

See section 9.1 for explanation of this readout.



#### CAUTION!

The Mass Combi is not protected against reversing polarity of the DC-input, AC voltage on the DC-input and serious over voltage (>265VAC) on the AC-input or AC-outputs.

### 4.3.1 Transfer switch overload protection

The transfer switch of the Mass Combi is protected against overload and short circuit. When the current through the transfer switch of the Mass Combi is too high (see figure 34) the thermal fuse (figure 22) will switch off and the Mass Combi shuts down.

To correct this situation, proceed as follows:

- 1 Move the main switch of the Mass Combi to the “OFF”-position.
- 2 Disconnect the Mass Combi from any power source. Disconnect all loads from the Mass Combi.
- 3 Investigate the cause of failure of the thermal fuse like overload or short-circuits.
- 4 Refer to section 5.5 to open the connection compartment
- 5 Wait for at least two minutes and then reset the thermal fuse by pushing the button inside the connection compartment (see figure 16).

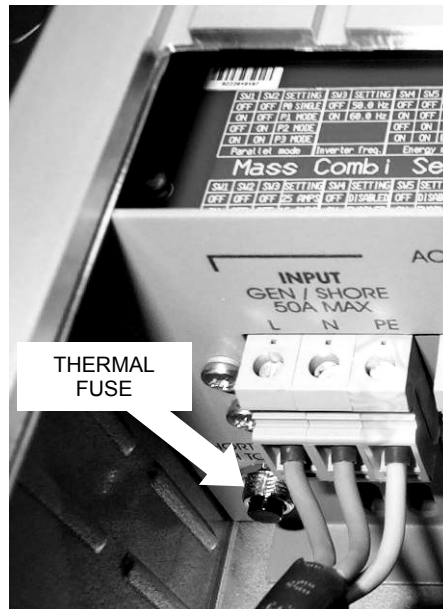

Figure 16: Reset of the thermal fuse

- 6 Close the connection compartment again.
- 7 Connect the Mass Combi to the power sources again.
- 8 Switch on the Mass Combi. (see section 4.2)

#### 4.3.2 Output overload or short circuit

In case of overload or short circuit in the inverter mode, the 100% LED of the Power bar (see figure 15) is illuminated red and the output voltage of the Mass Combi is limited. The Mass Combi shuts down if this overload or failure lasts longer than 5 seconds.

The Mass Combi will automatically restart after shutdown. After 5 failed start attempts the Mass Combi shuts down permanently, the 100% LED is lit and the Inverter LED (see figure 15) will flash. You can restart the Mass Combi only by switching the unit manually off and on with the main switch on the Mass Combi after the overload is removed or failure is solved.

#### 4.3.3 Overheating

In the event of overheating the Mass Combi shuts down (see chapter 9.1 for illumination of indicator lights). The Mass Combi is automatically powered up again when the temperature drops below the factory default threshold.

Overheating is most likely caused by:

- heavy or non-resistive loads operating for a longer time
- high ambient temperature
- disrupted air flow (dust or too less space)

#### 4.3.4 Under and over voltage

The AC-input of the Mass Combi is, within limits, protected against over and under voltage. See specifications in section 10.2. The Mass Combi will switch to inverter mode if the AC-input voltage is out of operating range and will switch back if the AC-input voltage is present again.

The DC-input of the Mass Combi is also, within limits, protected against over and under voltage. See specifications in section 10.1. The Mass Combi switches off if the DC-input voltage is out of range.

## 4.4 MAINTENANCE

No specific maintenance is required. If necessary, use a soft clean cloth to clean the Mass Combi. Never use any liquids, acids and/or scourers.

## 4.5 PROBLEM SOLVING

Refer to chapter 9 if a problem occurs.



## 5 INSTALLATION

During installation and commissioning of the Mass Combi, the Safety Guidelines & Measures are applicable at all times. See chapter 2 of this manual.

### 5.1 UNPACKING

In addition to the Mass Combi the delivery includes:

- a battery temperature sensor;
- MasterBus - Serial interface + crossed wired RS232 cable (60 cm);
- this user's manual.

After unpacking, check the contents for possible damage. Do not use the product if it is damaged. If in doubt, contact your supplier.

Check from the identification label (see section 1.6) whether the battery voltage is the same as the DC-input voltage of the Mass Combi (e.g. 24V battery set for a 24V input voltage). Also check that the AC output voltage and output power of the Mass Combi satisfies loading requirements.

### 5.2 ENVIRONMENT

Obey the following stipulations during installation:

- The Mass Combi is designed for indoor use only.
- Ambient temperature: 0 ... 60°C / 32°F ... 140°F; (power derating above 25°C / 104°F to decrease the internal heat sink temperature)
- Humidity: 0-95% non condensing
- Mount the Mass Combi on a solid surface, with the connecting cables downwards.
- Make sure that the hot air produced during operation can be discharged. The Mass Combi must be mounted in such a way that obstruction of the airflow through the ventilation openings will be prevented.
- No objects must be located within a distance of 10 cm / 4 inch around the Mass Combi. See also section 5.7.
- Do not locate the Mass Combi in the same compartment as the batteries.
- Do not install the Mass Combi straight above the batteries because of possible corrosive sulphur fumes

### 5.3 WIRING

The wiring is connected inside the connection compartment. If necessary, the wiring can be fed from the top to the bottom side of the cabinet along the back of the cabinet.

Always feed the wiring through the cable glands of the cabinet, and then connect the wiring to the terminals. Fix the phase line wire to terminal L, the neutral wire to terminal N and the ground wire to terminal PE.

#### 5.3.1 AC-wiring

For a safe installation the correct wire cross section must be applied. Don't use a cross section that is smaller than indicated. See table below to select the appropriate cross section for the AC wiring:

AC-Current	Minimum cross section:	
	in mm <sup>2</sup>	AWG
15-20 Amp	2.5 mm <sup>2</sup>	AWG 13
20-32 Amp	4 mm <sup>2</sup>	AWG 11
32-48 Amp	6 mm <sup>2</sup>	AWG 9
48-80 Amp	10 mm <sup>2</sup>	AWG 7

Recommended wire colours (refer to local rules):

- 230V AC installations:

Wire color	Meaning	Must be connected to:
Brown or black	Phase	L1
Blue	Neutral	N
Green/Yellow	Earth	PE / GND

The maximum current passing the Mass Combi must be limited. Therefore the AC-input must be protected by a fuse, as specified below.

Model Mass Combi	Maximum rating of the AC input fuse
All models	50A

**5.3.2 DC wiring**

Keep in mind that high current will pass through the DC wiring. Keep the cable length as short as possible, this will keep the system efficiency as high as possible. See section 10.1 Specifications for recommended DC wire sizes.

Use cable lugs terminals on the ends of the wires. These lugs should be crimped with a proper crimping tool. Use the following wire colours for DC wiring (refer to local rules):

Wire color	Meaning	Must be connected to:
Red	Positive	+ (POS)
Black	Negative	- (NEG)

Lay the positive and negative cables next to each other to limit the electro magnetic field around the cables. The negative cable should be connected directly to the negative post of the battery bank or the ground side of a current shunt. Do not use the chassis frame or hull of the ship as the negative conductor. Tighten connections securely (15 - 20 Nm / 130 - 175 In-Lbs.). The positive battery cable must be fused according to local applicable regulations and connected to the positive post of the battery bank.

See section 10.1 Specifications for recommended fuses.

The fuse with the fuse-holder is available from your local Mastervolt distributor or Customer Service Representative.

**5.3.3 AC safety grounding**



**WARNING**

The ground wire offers protection only if the cabinet of the Mass Combi is connected to the safety ground. Connect the earth terminal (PE / GND) to the hull or the chassis.



**CAUTION!**

For safe installation it is necessary to:

- connect the neutral conductor (N) of the AC output to the earth (PE / GND), only during inverter operation of the Mass Combi;
- insert a Residual Current Device (earth leakage switch) of 30mA in AC output "SHORT BREAK" of the Mass Combi.
- Insert a Residual Current Device (earth leakage switch) of 30mA in AC input of the Mass Combi.

Refer to local regulations on these issues!

For safety purposes the neutral conductor (N) of the AC output must be connected to the earth (PE / GND) when the Mass Combi is in inverter operation. When utility power is available on the AC input, and the Mass Combi is in charger mode, this connection must be disabled again.

In some applications automatic connection between the neutral conductor (N) and earth (PE / GND) is not required or acceptable. Therefore the automatic connection between the neutral conductor (N) and earth (PE / GND) is disabled by default

To enable this automatic connection, see section 6.1.5

## 5.4 THINGS YOU NEED

Make sure you have all the parts you need to install the Mass Combi:

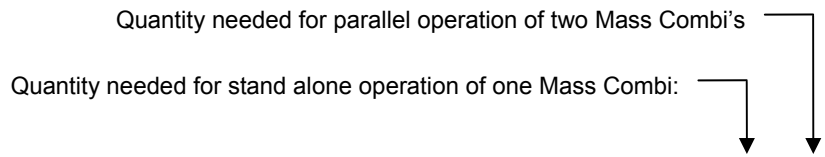

Mass Combi (included)	1	2
MasterBus – Serial interface + connection cable 60 cm (included)	1	1
Battery temperature sensor with cable and plug (included).	1	2
DC-cable to connect the positive DC connection (+) of the Mass Combi to the plus pole of the DC-distribution; for specifications see section 10.1, maximum recommended length: 2m / 6ft, colour: preferably red or at least a different colour to make a clear distinction between the positive and negative wire from the battery	1	2
DC-cable to connect the negative DC connection (-) of the Mass Combi to the negative pole of the DC-distribution; for specifications see section 10.1, maximum recommended length: 2m / 6ft, colour: preferably black or at least a different colour to make a clear distinction between the positive and negative wire from the battery.	1	2
DC-fuse holder with a DC-fuse, to be integrated in the positive DC-cable. For specifications see section 5.3.2.	1	2
Screws / bolts (Ø 6mm) (with plugs) to mount the cabinet to a surface. Use mounting materials which are suitable to carry the weight of the Mass Combi	4	8
AC cable* to connect the AC input of Combi A to an external power source (e.g. a shore connection or a generator set);	1	1
AC cable* to connect the external load to the AC “Power” output of Combi A.	1	1
AC cable* to connect the external load to the AC “SHORT BREAK” output of Combi A.	1	1
AC cable* to connect the AC “SHORT BREAK” outputs of both Combi A and B to each other. Maximum length: 15m	–	1
Batteries. Refer to section 10.1 for specifications.	X	X
Appropriate and reliable cable terminals, cable lugs, battery terminals and cord end terminals	X	X
Modular communication cable 8 pole (maximum length 15m) for communication between the two Mass Combi’s. See figure 20.	–	1

\* Double insulated three wire cable with wire colours according to the locally applicable regulations. The applicable length and wire diameter depend on the electrical installation (see section 5.3.1).

We recommend as a minimum tool kit:

- Socket wrench 13mm to fix the DC-input (battery) cables
- Flat blade screw driver 1.0 x 4.0 mm to fix the screw terminals
- Tools to fix the screws / bolts (Ø 6mm) with plugs to mount the cabinets to a surface
- Philips screw driver to open the connection area of the Mass Combi

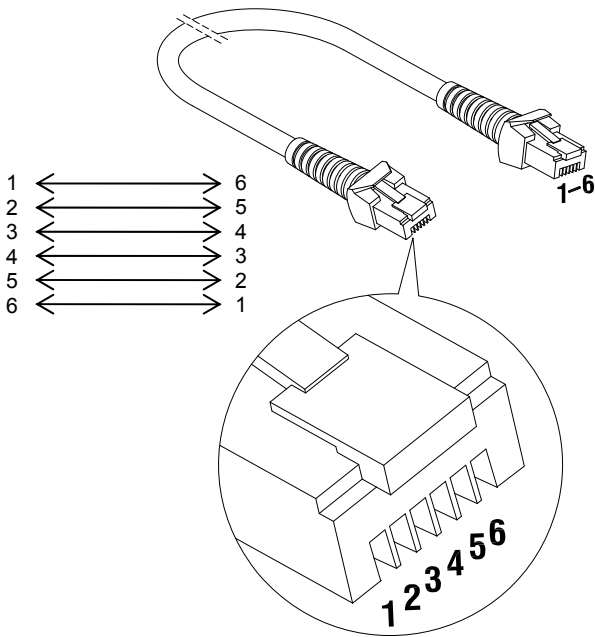

Figure 19: Modular communication cable, 6 pole, cross wired. For connection of remote control panels

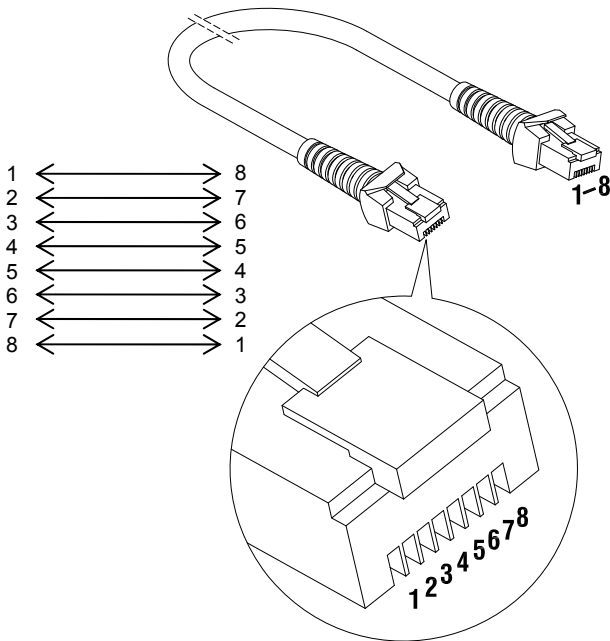

Figure 20: Modular communication cable, 8 pole, cross wired. For communication between two Mass Combi's (parallel operation)

### 5.5 REMOVAL OF THE FRONT PANEL

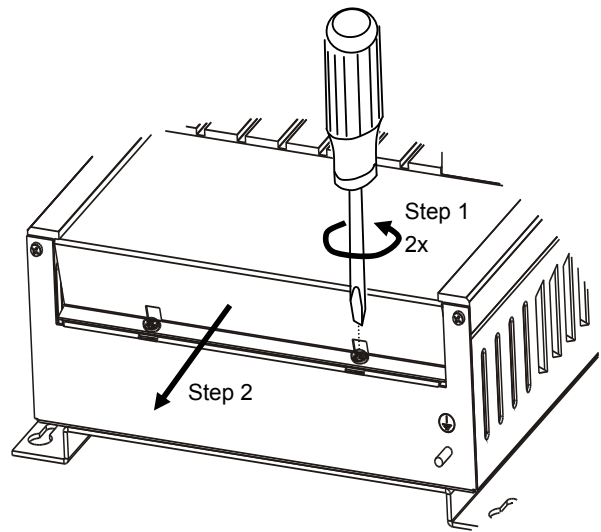

Figure 21

See figure 21. Steps:

- 1 Loosen the two Phillips screws that secure the front cover plate for two turns.
- 2 Slide the front cover plate from the cabinet (downwards).

The connectors for the battery, the AC and the remote panel are now visible. See figures 22 and 23



**WARNING**

The front panel may never be removed while the Mass Combi is still connected to a power source!

**5.6 OVERVIEW CONNECTION COMPARTMENT**

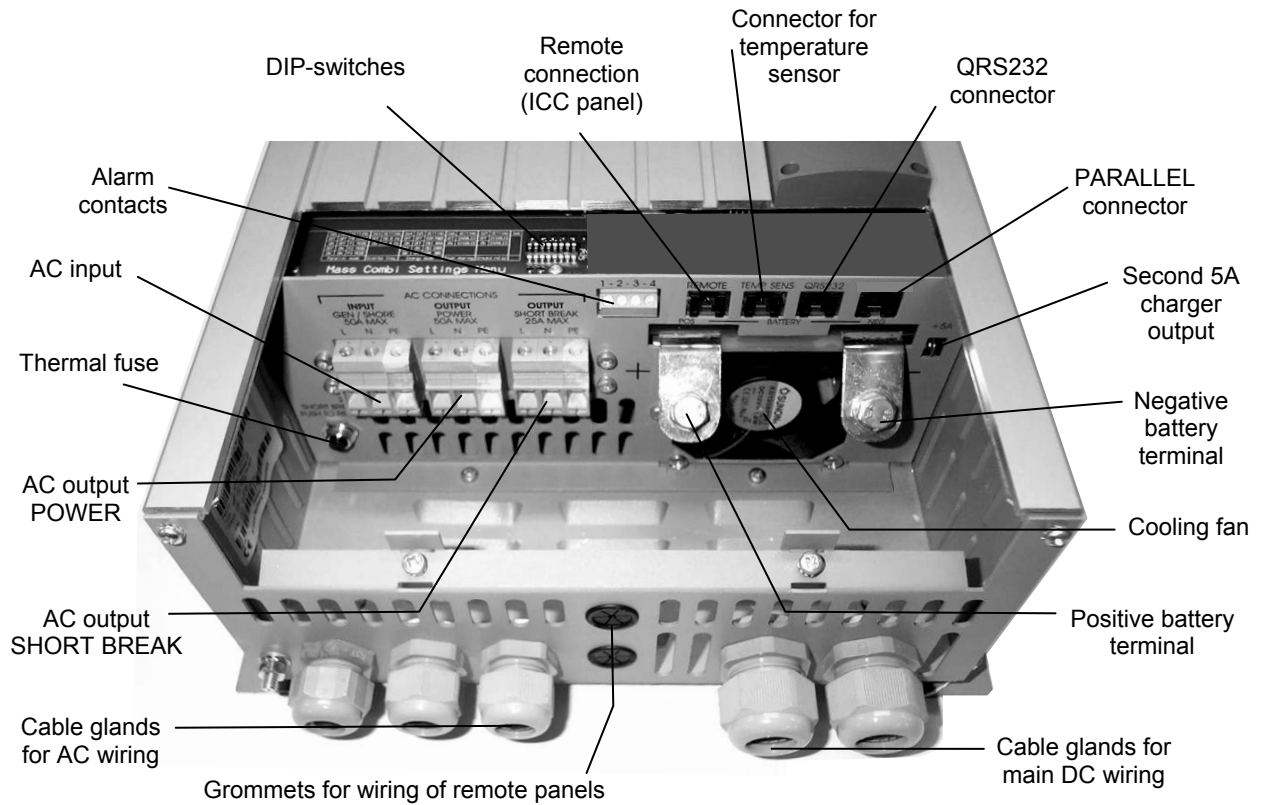

Mass Combi models 12/2500-100, 24/2500-60 and 48/2500-35

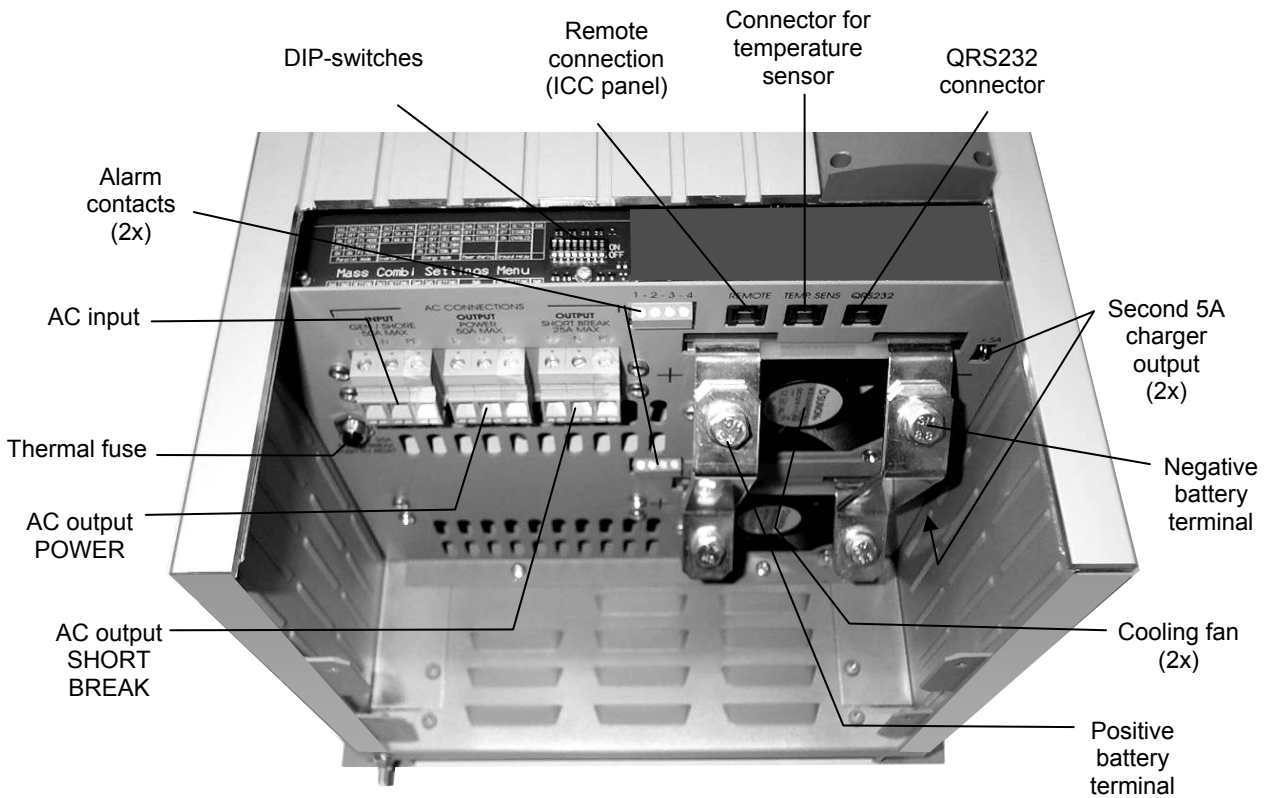

Mass Combi model 48/5000-70

Figure 22: Overview connection compartment

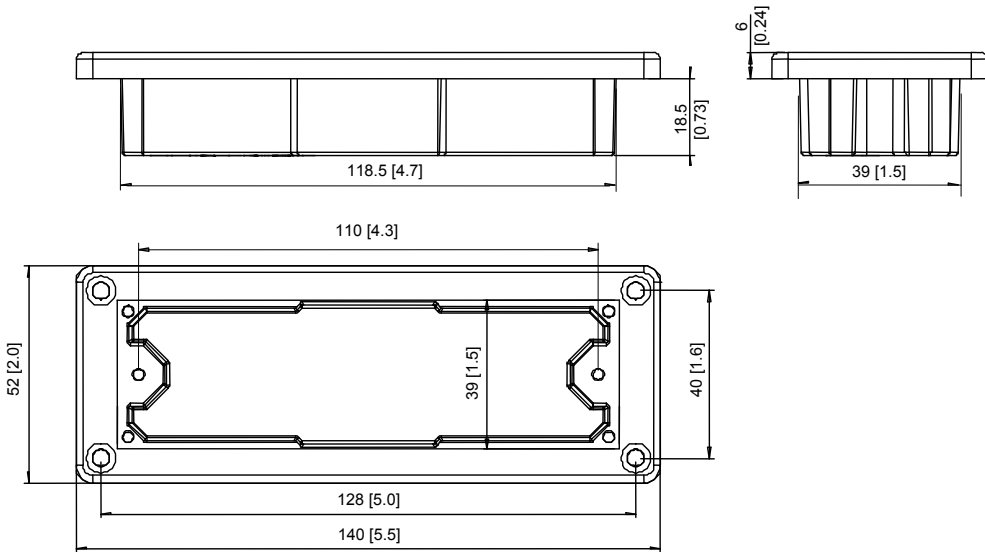

Figure 23: Dimensions in mm [inch] of the mounting box of the ICC remote panel and the APC remote panel

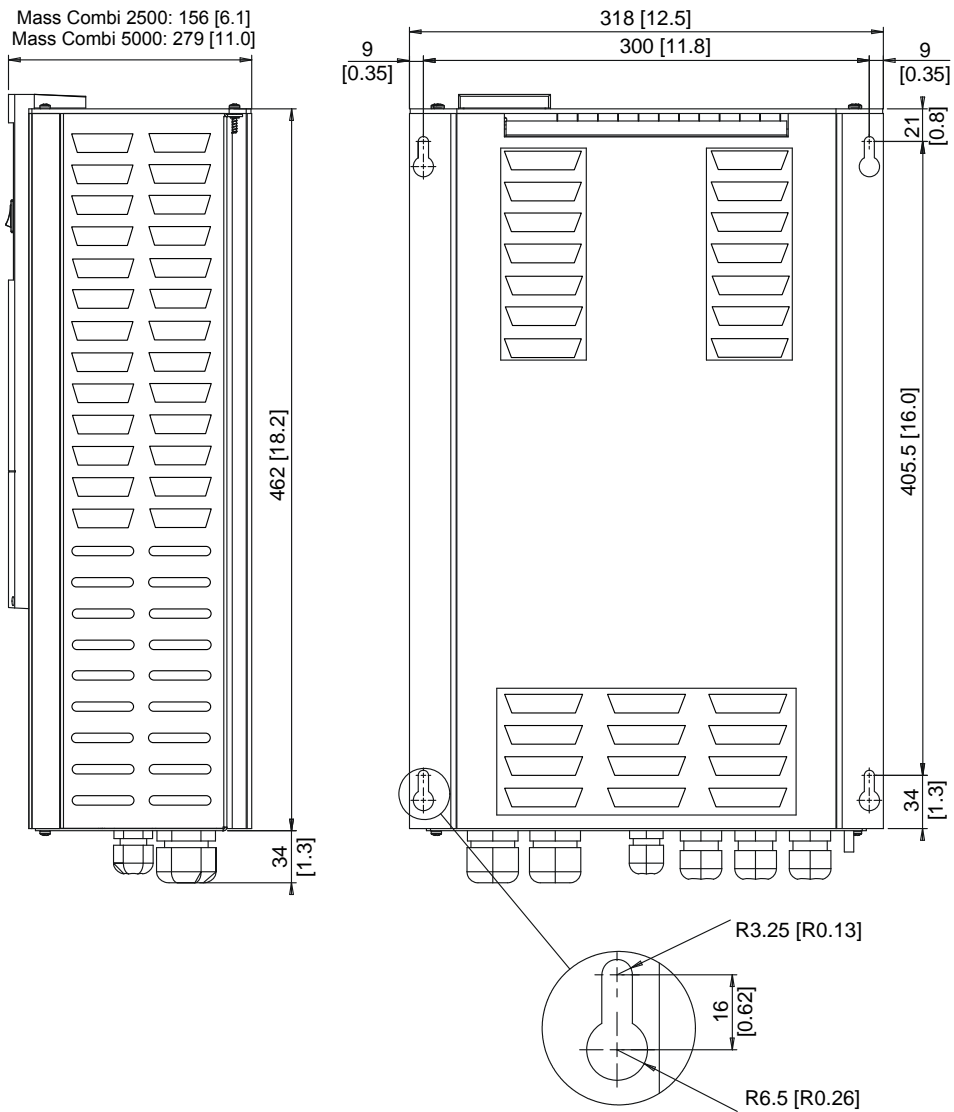

Figure 24: Dimensions in mm [inch] of the Mass Combi 12/2500-100, 24/2500-60, 48/2500-35 and 48/5000-70

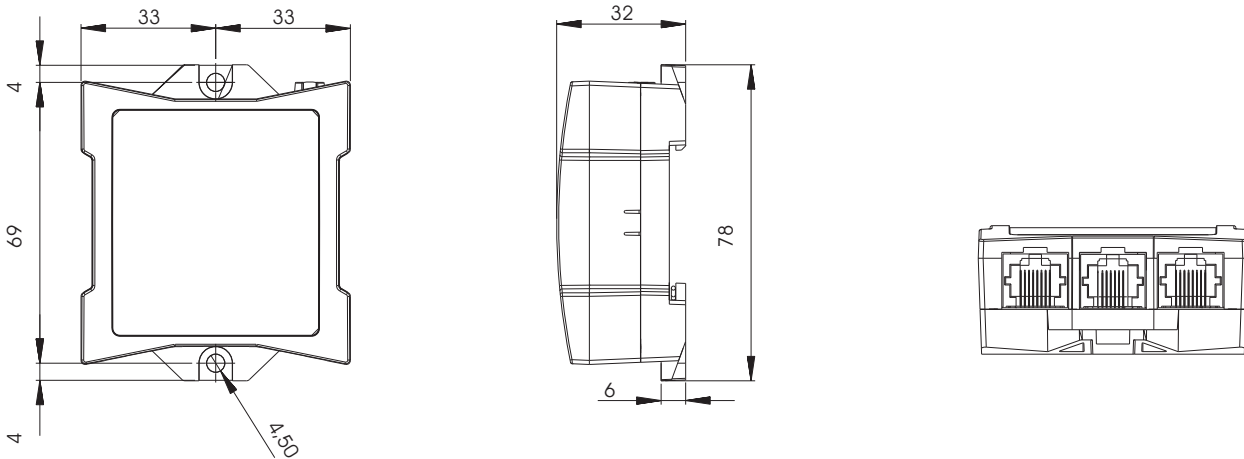

Figure 25: Dimensions in mm of the MasterBus – Serial interface

## 5.7 MOUNTING OF THE CABINET

M6 bolts can be used for the mounting of the cabinet.

Take the following steps to mount the cabinet:

- 1 Determine for the four mounting spots on the basis of the outline drawings (figure 24)
- 2 Screw the topmost bolts somewhat into the wall.
- 3 Hang the cabinet with its key holes over the two bolts and screw these bolts finger tight, so that some shifting is still possible.
- 4 Place the two lowermost bolts.
- 5 Fasten all bolts securely.

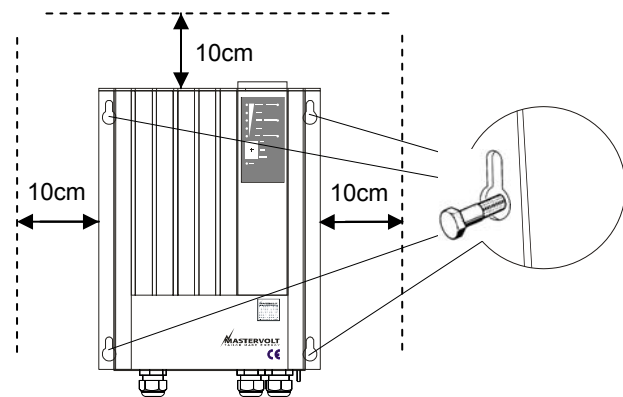

Figure 26: mounting of the cabinet

## 5.8 WIRING INSTRUCTIONS



### WARNING

Let installation work be done by a licensed electrician. Before beginning with the connection of the wiring, make the AC distribution as well as the DC distribution voltage free. Move the main switch (see figure 15) to the “Off”-position.



### CAUTION!

Short circuiting or reversing polarity may lead to serious damage to the batteries, the Mass Combi, the wiring and/or the terminal connections. Fuses between the batteries and the Mass Combi can not prevent damage caused by reversed polarity. The damage as a result of reverse polarity is not covered by the warranty.



### CAUTION!

Too-thin cables and/or loose connections can cause dangerous overheating of the cables and/or terminals. Therefore tighten all connections well, in order to limit transition resistance as far as possible. Use cables of the correct size



### NOTE!

Feed the cables through the cable glands of the cabinet before you fix the cable lugs to the wire ends.

Continue with section 5.8.1 for wiring instructions of one Mass Combi in stand alone operation or section 5.8.2 for wiring instructions of two Mass Combi's in parallel operation.

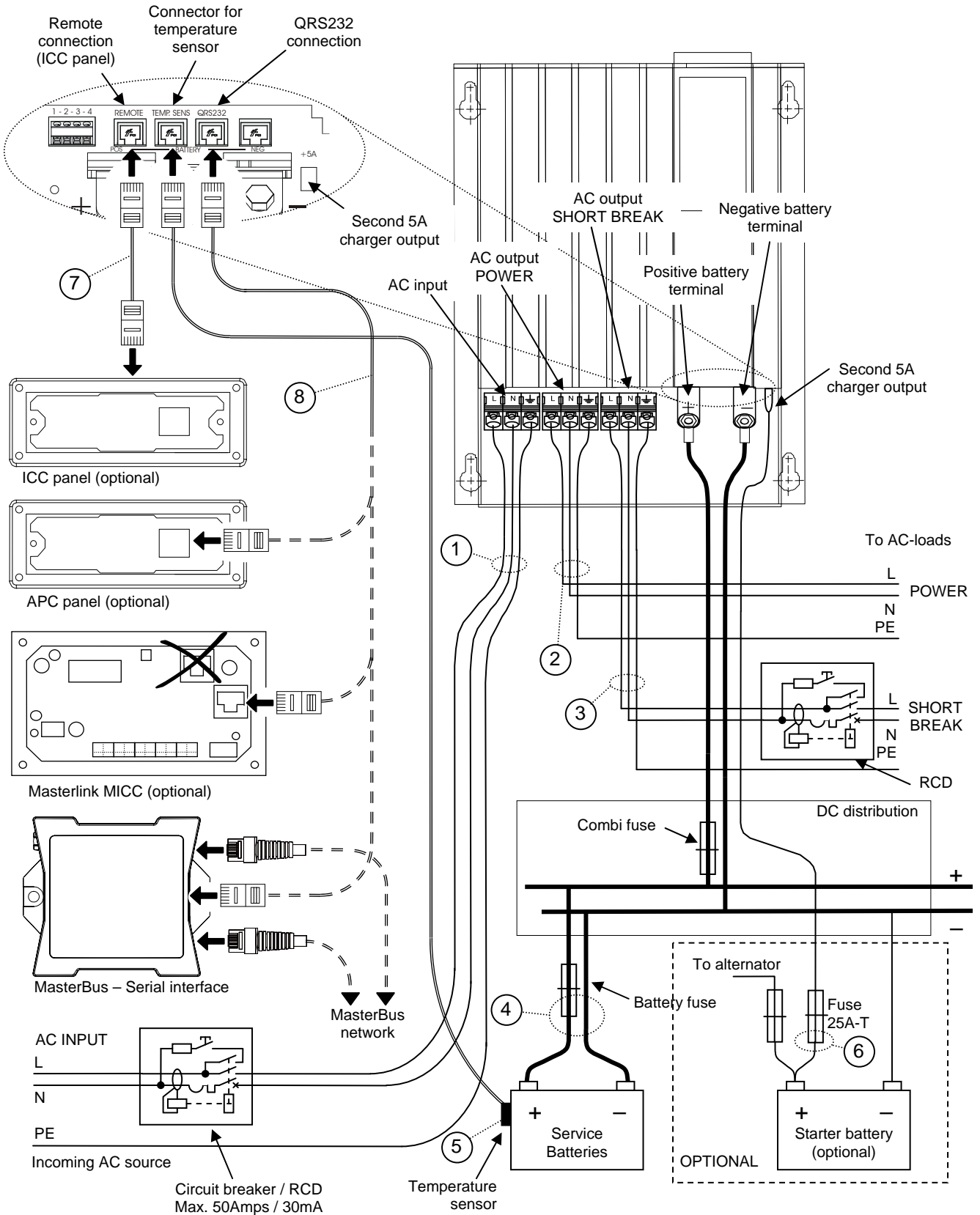

This schematic is to illustrate the general placement of the Mass Combi in a circuit. It is not meant to provide detailed wiring instructions for any particular electrical installation.

Figure 27: installation drawing for one Mass Combi (stand-alone operation)



### 5.8.1 Wiring instructions for one Mass Combi (stand alone operation)

See figure 27.

- 1 See reference ①. Connect the external AC-source to the AC-input of the Mass Combi. Integrate a fuse (value depending on the used wire diameter with a maximum of 50Amps) and a Residual Current Device (RCD) into this wiring.
- 2 See reference ②. Connect the AC-output POWER of the Mass Combi to the power distribution group.
- 3 See reference ③. Connect the output SHORT BREAK of the Mass Combi to the SHORT BREAK distribution group. Integrate a Residual Current Device (RCD) into this wiring.
- 4 See reference ④. Run the DC-cables between the DC-distribution and the Mass Combi. Connect the red cable to the plus (+) connection, the black cable to the minus (-) connection. Do not install the DC-fuse of the DC-distribution before the entire installation is completed (see chapter 7).
- 5 See reference ⑤. Attach the temperature sensor to the battery and run the cable into the Mass Combi. Link the RJ12 connector to the "TEMP.SENS"-connector (Data Bus Connections).
- 6 Option: if you want to make use of the possibility to give a maintenance charge to a small battery set (like a starter battery), run a 6mm<sup>2</sup> /AWG10 red cable with a fuse holder between the positive pole of the starter battery and Mass Combi. See figure 27, reference ⑥. Fix the cable with an insulated faston to the "+5A"-connection. Integrate a 25 Amps-T fuse in this wire. The negative pole of this battery must be connected to the negative pole of the service battery.
- 7 See reference ⑦. If you want to install the ICC remote control panel, run the communication cable between the Mass Combi and the panel. Connect the RJ12 connector to the "REMOTE"-input (Data Bus Connections)

**NOTE!**

The Mass Combi can also be operated without the ICC remote control panel connected.

- 8 The MasterBus – Serial interface or other panels than the ICC remote control panel must be connected to the "QRS232"-connection; reference ⑧. Refer to the applicable installation manual for instructions.

Continue with section 5.8.3

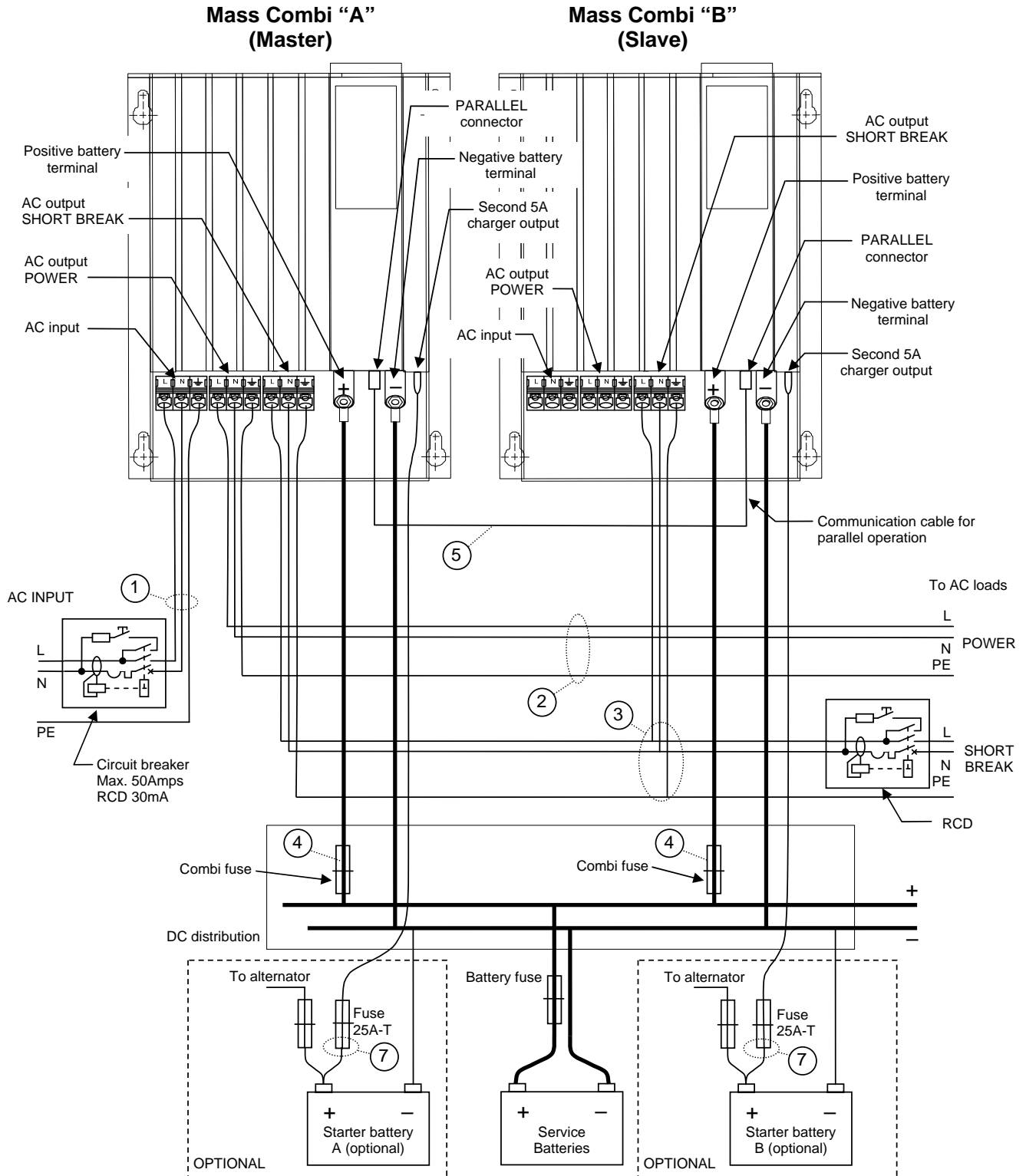

This schematic is to illustrate the general placement of the Mass Combi in a circuit. It is not meant to provide detailed wiring instructions for any particular electrical installation.

NOTE: See also section 6.1.1 for DIP-switch settings

Figure 28: installation drawing for two Mass Combi's (parallel operation). See also figure 29

## 5.8.2 Wiring instructions for two Mass Combi's (parallel operation)



### CAUTION!

Only two units of the Mass Combi 12/2500-100, Mass Combi 24/2500-60 or the Mass Combi 48/2500-35 can be connected in parallel. Parallel operation of two units of the Mass Combi 48/5000-70 is not possible



### CAUTION!

Only two units of the Mass Combi can be connected in parallel. Parallel operation with other Combi's or inverters is not possible.

In the text below the Mass Combi that is designated as "A" must be configured as Master, while the Mass Combi that is designated as "B" must be configured as Slave (see section 6.1.1 for adjustment).

Designation:	must be configured as:
Combi A	Master
Combi B	Slave

- See figure 28, reference ①. Connect the external AC-source to the "AC input" terminals of Mass Combi "A". Integrate a fuse (value depending on the used wire diameter with a maximum of 50Amps) and a Residual Current Device (RCD) into this wiring.
- See reference ②. Connect the "AC output POWER" of Combi "A" to the power distribution group.
- See reference ③. Connect the "AC output SHORT BREAK" of both Mass Combi "A" and Mass Combi "B" to the SHORT BREAK distribution. Beware that the L, N and PE / GND wiring may not be exchanged.
- See reference ④. Run the DC-cables between the DC-distribution and each Mass Combi. Connect the red cable to the plus (+) connection, the black cable to the minus (-) connection. Do not install the DC-fuses

of the DC-distribution before the entire installation is completed (see chapter 7).

- See figure 29, reference ⑤. Run the modular 8-pole communication cable between Mass Combi "A" and Mass Combi "B". Connect this cable to the PARALLEL connectors.
- See reference ⑥. Attach the temperature sensor to the battery and run the cable into Mass Combi "A" and connect the RJ12 connector to the "TEMP.SENS"-connector (Data Bus Connections)
- Option: if you want to make use of the possibility to give a maintenance charge to a small battery set (like a starter battery), run a 6mm<sup>2</sup> /AWG10 red cable with a fuse holder between the positive pole of the starter battery and Mass Combi. See figure 28, reference ⑦. Fix the cable with an insulated faston to the "+5A"-connection. Integrate a 25 Amps-T fuse in this wire. The negative pole of this battery must be connected to the negative pole of the main battery.
- See figure 29, reference ⑧. If you want to install the ICC remote control panel, run the communication cable between Mass Combi A and the panel. Connect the RJ12 connector to the "REMOTE"-input (Data Bus Connections) of Mass Combi A.



### NOTES

- The Mass Combi can also be operated without the ICC remote control panel connected.
  - With two Mass Combi's installed in parallel, each Combi can also have its own ICC remote control panel.
- The MasterBus – Serial interface or other panels than the ICC remote control panel must be connected to the "QRS232"-connection; reference ⑨. Refer to the applicable installation manual for detailed instructions.

Continue with section 5.8.3

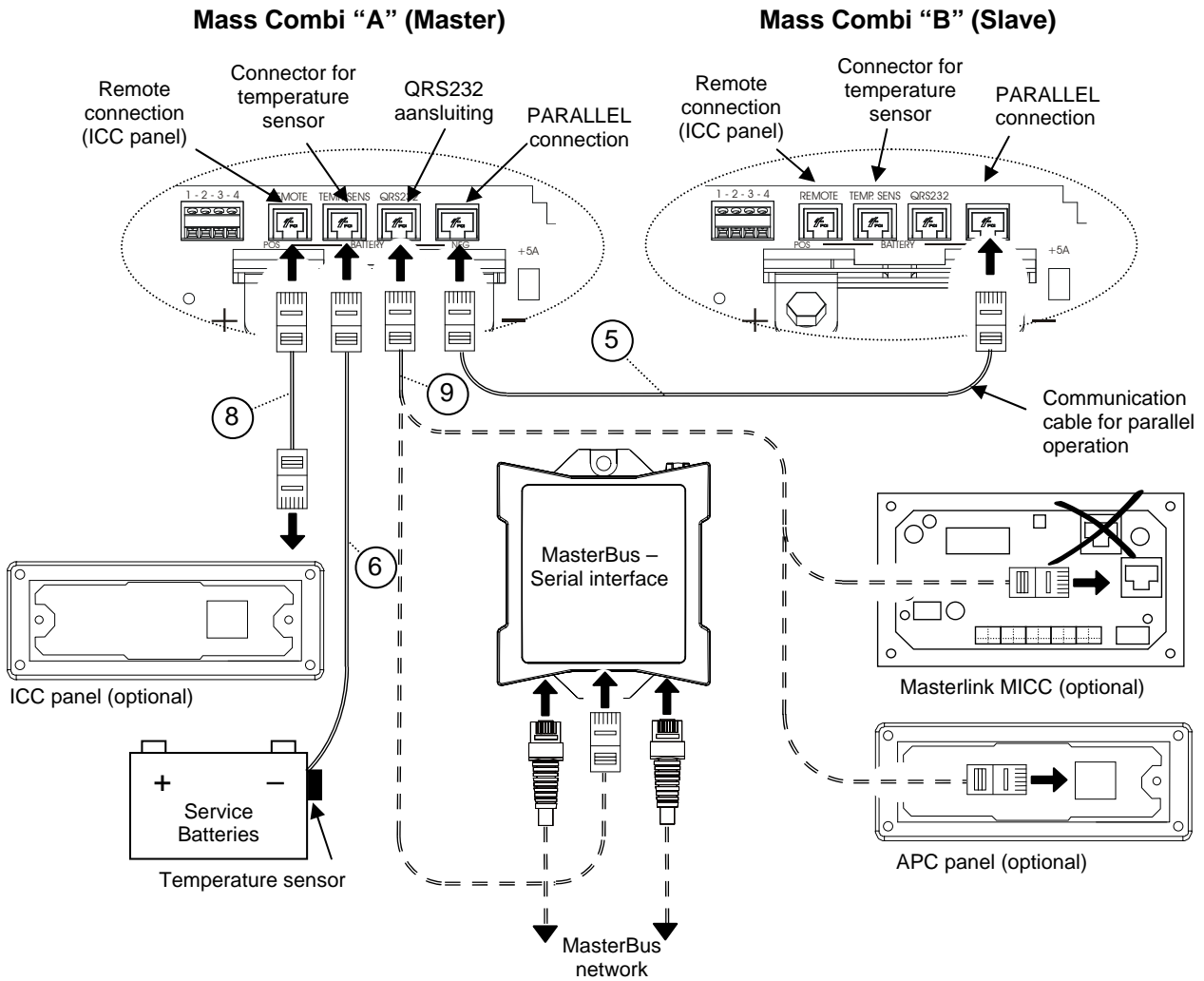

Figure 29: Connection of remote control panels, battery temperature sensors and communication cable for parallel operation

**5.8.3 Alarm contacts**

Connectors 1 to 4 are internally linked as follows:

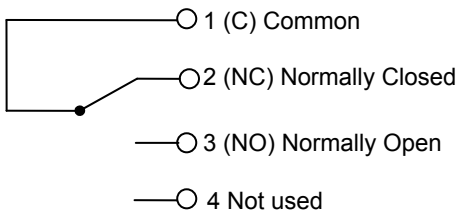
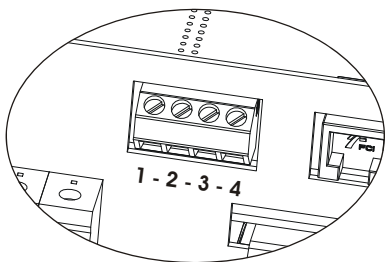

Figure 30: alarm contacts

The alarm contact is switched to “Normally Open” in case of an alarm situation, see section 3.6. Maximum switching current: 1 Amp.

**5.9 SETTINGS**

See chapter 6 for DIP-switch settings.

**NOTE:** Adjust the DIP-switches prior to commissioning!

**NOTE:** When using a Masterlink MICC remote panel:

- See section 6.2.5 for DIP-switch setting at the Mass Combi;
- See section 4.4 of the user’s manual of the Masterlink MICC to enable the Mass Combi setting.

## 6 SETTINGS

The Mass Combi is provided with two groups of DIP-switches to adjust the apparatus according to the specifications of the electrical installation. The DIP-switches are located in the connection compartment. See figure 31.

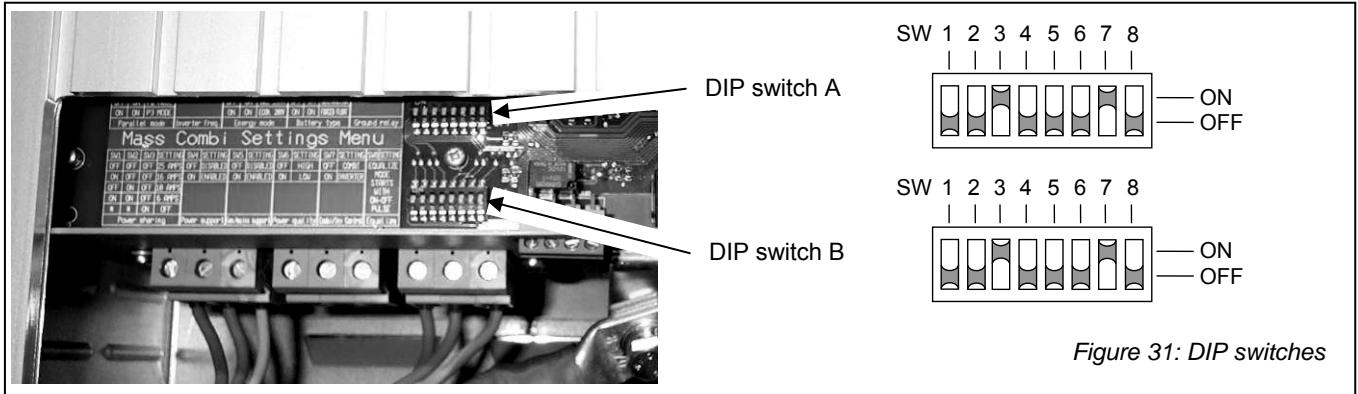

Figure 31: DIP switches

### 6.1 DIP SWITCH A

#### 6.1.1 Parallel mode

If you want...	DIP switch A	
	SW1	SW2
to configure the Combi as Master (Combi A) then...	OFF	OFF
to configure the Combi as Slave (Combi B) then...	ON	ON
to configure the Combi as Slave (Combi B) having its own charge characteristics then... (only when both Combi A and Combi B have their own battery set)	OFF	ON

NOTES:

- If the Combi is configured as Slave, then the settings of SW3 to SW8 of DIP switch A and SW1 to SW7 of DIP switch B are denied.
- If the charge characteristics of the Combi that is configured as Slave (Combi B) are set to follow the Master (DIP Switch A: SW1= ON) then its settings SW6 to SW7 of DIP switch A are denied.

#### 6.1.2 Output frequency inverter

230V Models	DIP switch A
If you want...	SW3
to set the output frequency to 50 Hz	OFF
to set the output frequency to 60Hz	ON

### 6.1.3 Energy saving mode

See section 3.2.2 for more information.

If you want...	DIP switch A	
	SW4	SW5
High Power (Energy saving disabled).	OFF	OFF
Idle 40VA. When it detects a load that is >40VA, it switches on the output power automatically.	ON	OFF
Idle 150VA. When it detects a load that is >150VA, it switches on the output power automatically	OFF	ON
Economy 208V. The output voltage will drop to 208V as long as the connected load stays below 250VA.	ON	ON

Note: The power saving modes "Idle 40VA" or "Idle 150VA" can only be selected with a Mass Combi 12/2500-100, Mass Combi 24/2500-60 or the Mass Combi 48/2500-35 operating as stand-alone unit. **These modes are not available with a Mass Combi 48/5000-70 or two Mass Combi's in parallel operation.**

### 6.1.4 Battery type

The factory setting for the battery type is optimal for most installations. In some applications however, it is desirable to change this setting. Adjust the Mass Combi to the applied batteries by adjusting DIP switches SW6 and SW7.

Wrong adjustment can cause damage to your batteries which is not covered by the warranty.

**The setting for traction battery should never be used with a battery bank that consists of 2V GEL cells!**

If you want...	DIP switch A	
	SW6	SW7
Standard battery (factory setting)	OFF	OFF
Gel / AGM / spiral battery. During the float stage of the charging cycle the output voltage will be higher (+ 0.55V @ 12V / + 1.1V @ 24V / + 2.2V @ 48V)	ON	OFF
Traction battery. Charging voltage will be increased during the bulk stage (+ 0.7V) and the absorption stage (+ 0.4V)	OFF	ON
Forced float. When activated, the three stage charging program is changed to a single stage program.	ON	ON
Fixed output voltage: 13.8V (@12V), 27.6V (@24V) or 55.2V (@48V)		

### 6.1.5 Ground relay

The ground relay function allows you to connect the Neutral conductor (N) of the inverter output circuit to the Safety Ground (PE / GND) automatically when the Mass Combi is working as an inverter. With most electrical installations in the USA this ground relay must be set to ON. Refer to local regulations on this issue.

If you want...	DIP switch A
	SW8
no internal connection between the Neutral (N) and the Safety Ground (PE / GND) when the Mass Combi is working as an inverter	OFF
the Neutral wire (N) of the inverter output circuit connected to the Safety Ground (PE / GND) when the Mass Combi is working as an inverter and disconnected when incoming AC-power is applied (charger / transfer mode).	ON

## 6.2 DIP SWITCH B

### 6.2.1 Power sharing function

See section 3.3.3 for more information.

230V Models If you want...	DIP switch B		
	SW1	SW2	SW3
To limit the AC-input current to 25 Amps.	OFF	OFF	OFF
To limit the AC-input current to 16 Amps.	ON	OFF	OFF
To limit the AC-input current to 10 Amps.	OFF	ON	OFF
To limit the AC-input current to 6 Amps.	ON	ON	OFF
To disable the Power sharing function.	---	---	ON

### 6.2.2 Power Support Function

See section 3.3.5 for more information.

If you want...	DIP switch B SW4
To disable the Power support function	OFF
To enable the Power support function	ON

### 6.2.3 Generator / mains support function

See section 3.3.4 for more information.

If you want...	DIP switch B SW5
To disable the Generator / mains support function	OFF
To enable the Generator / mains support function	ON

### 6.2.4 Setting for Power Quality at incoming AC

If a generator with distorted output waveform (too low frequency) is used as AC source, the allowed frequency window for the incoming AC power can be enlarged.

If you want...	DIP switch B SW6
To set the frequency window for the incoming AC power at $45\text{Hz} < f < 65\text{Hz}$	OFF
To set the frequency window for the incoming AC power at $35\text{Hz} < f < 65\text{Hz}$	ON



#### CAUTION!

Adjustment of the frequency window at a too low level may cause damage to the connected AC-load. Refer to the AC-input specifications of the connected loads.

**6.2.5 Combi/inverter control**

The ON/OFF switch at the Inverter Charger Control (ICC) has a function depending on the setting of DIP-switch number 7.

When the Mass Combi is switched off by means of the main switch at the front then it is completely off (see 4.2). However, in this off state it is not possible to start the Mass Combi remotely via the ICC remote panel. This is independent from the setting of DIP-switch number 7.

If you want to charge your batteries only and you do not want to start the inverter function when incoming AC fails, then the main switch of the Mass Combi must be set to the “Ch.” position (Charger only see 4.2.3). In this state it is not possible to switch the Mass Combi remotely on or off. This is independent from the setting of DIP-switch number 7.

If you want...	DIP switch B SW7
To switch the Mass Combi (inverter and charger function) remotely on or off. The main switch at the front of the Mass Combi has to be set to the ON position	OFF
To switch the inverter function of the Mass Combi remotely on or off when AC-in fails. With this setting the charger is always active when the AC-in is available. The main switch at the front of the Mass Combi has to be set to the ON position.	ON



**NOTE:**

The Mass Combi is not entirely off when the Mass Combi is switched off by means of the ICC remote panel. The no load drain is less than 5mA and is used to keep the data buses connected to the remote panels active

**6.2.6 Equalize mode**



**WARNING**

Incorrect use of the equalize mode may lead to hazardous situations



**WARNING**

Equalization is ONLY applicable for wet type batteries and will damage gel and AGM type batteries..



**WARNING**

Do not smoke; use any naked flame or other sources of ignition due to risk of explosion. Always ventilate the room where the batteries are located and equalized to clear the air..

The equalizing mode can only be started when the Mass Combi is in operation. This means that the connection compartment of the Mass Combi must be opened while connected to the mains and the batteries. Take adequate measures for protection against short circuits and electrical shocks.

During equalizing the batteries are brought into the gas state and it is possible that the permitted load voltages are exceeded. See chapter 10.4 for characteristics. Therefore appropriate measures must be taken, e.g. disconnect all loads from the battery and ventilate the room. For these reasons use of the equalizing mode should only be executed by trained technical engineers.

An equalizing charge can be necessary after very deep discharges and/or inadequate charges. This has to be carried out according to the specifications of the manufacturer of the batteries.

If you want...	DIP switch B SW8
To start the equalize mode	Off-On-Off pulse



## 7 START-UP AFTER INSTALLATION

### 7.1 COMMISSIONING

**CAUTION!**

Check the polarity of all wiring before commissioning: plus connected to plus (red cables), minus connected to minus (black cables)

**NOTE:**

The DIP-switches must be adjusted prior to commissioning; see chapter 6

Follow the steps described below to switch on the Mass Combi.

- 1 Tighten all cable glands to ensure the pull relief
- 2 Check all wiring and connections
- 3 Close the front cover plate of the connection compartment of the Mass Combi. Beware that the wiring does not obstruct the cooling fans and air flow.
- 4 Place the DC-fuse(s) of the DC-distribution to connect the batteries to the Mass Combi.

**WARNING**

When placing this fuse, a spark can occur, caused by the capacitors used in the Mass Combi. This is particularly dangerous in places with insufficient ventilation, due to the gassing of the batteries an explosion can occur and avoid having flammable materials close by.

Now the Mass Combi is ready for operation.

### 7.2 DECOMMISSIONING

If it is necessary to put the Mass Combi out of operation, follow the instructions in order of succession as described below:

- 1 Move the Main-switch of the Mass Combi to the "Off"-position (see figure 15).
- 2 Remove the DC-fuse(s) of the DC-distribution and/or disconnect the batteries.
- 3 Remove the AC-fuse(s) of the AC-input and/or disconnect the AC-mains.
- 4 Open the connection compartment of the Mass Combi (see section 5.5)
- 5 Check with a suitable voltage meter whether the inputs and the outputs of the Mass Combi are voltage free.
- 6 Disconnect all the wiring

Now the Mass Combi can be demounted in a safe way.

## 8 MASTERBUS

### 8.1 WHAT IS MASTERBUS?



All devices that are suitable for MasterBus are marked by the MasterBus symbol.

MasterBus is a fully decentralized data network for communication between the different Mastervolt system devices. It is a CAN-bus based communication network which has proven itself as a reliable bus-system in automotive applications. MasterBus is used as power management system for all connected devices, such as the inverter, battery charger, generator and many more. This gives the possibility for communication between the connected devices, for instance to start the generator when the batteries are low.

MasterBus reduces complexity of electrical systems by using UTP patch cables. All system components are simply chained together. Therefore each device is equipped with two MasterBus data ports. When two or more devices are connected to each other through these data ports, they form a local data network, called the MasterBus. The results are a reduction of material costs as only a few electrical cables are needed and less installation time.

For central monitoring and control of the connected devices Mastervolt offers a wide range of panels which show full status information of your electrical system at a glance and a push of a button. Four different panels are available, from the small Mastervision compatible 120 x 65mm LCD screen up to the full colour MasterView System panel. All monitoring panels can be used for monitoring, control and configuration of all connected MasterBus equipment. Mastervolt also offers a MasterBus – USB interface. With this interface in combination with – free to download – MasterAdjust Software, you can monitor and program all devices that are connected to the MasterBus by means of your PC or notebook. Refer to the “Frequently asked questions about *MasterBus*” in the Mastervolt Powerbook for more details about *Masterbus*,

### 8.2 HOW TO SET UP A MASTERBUS NETWORK

Each device that is suitable for the MasterBus network is equipped with two data ports. When two or more devices are connected to each other through these ports, they form a local data network, called the MasterBus.

Keep the following rules in mind:

Connections between the devices are made by standard straight UTP patch cables. Mastervolt can supply these cables. These cables are also commonly available at computer supply stores.

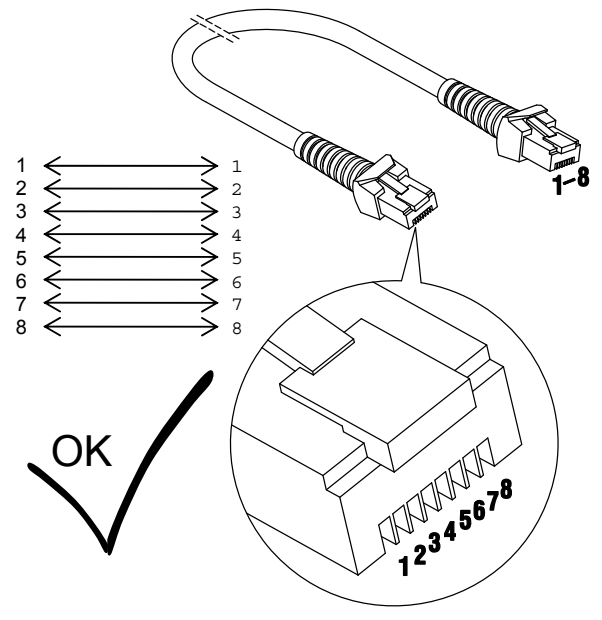

As with all high speed data networks, MasterBus needs a terminating device on both ends of the network

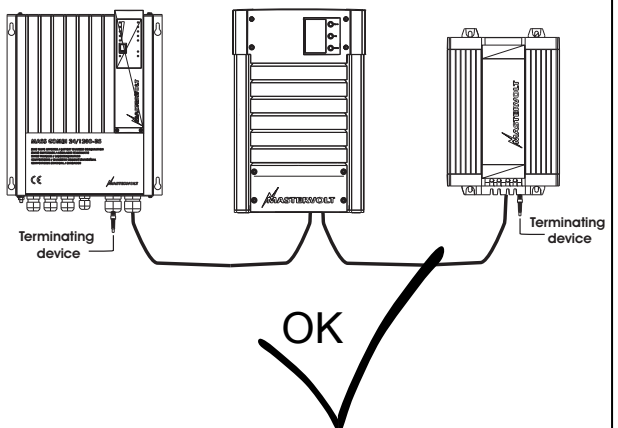

The electric power for the network comes from the connected devices.  
 At least one device in the network should have powering capabilities (see specifications).  
 One powering device can power up to three non-powering devices.  
 As all powering devices are galvanically isolated, multiple powering devices are allowed

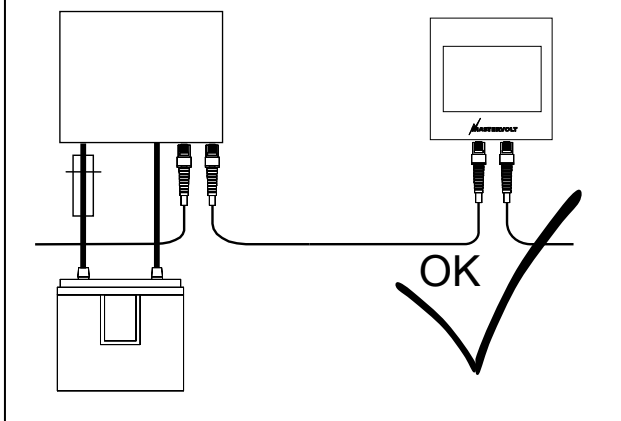

Do not make ring networks

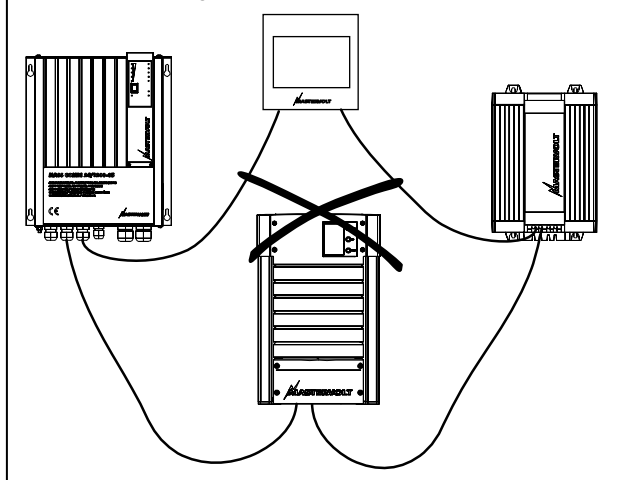

Do not make T-connections in the network

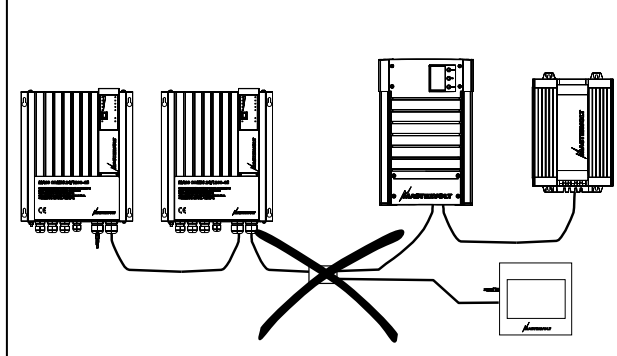

## 8.3 MASTERBUS: MONITORING AND CONFIGURATION OF THE MASS COMBI

### 8.3.1 Monitoring

Value	Meaning	Default	Adjustable range
<b>Basic setup</b>			
Mode	Operation mode of the Mass Combi. When “Charger” is selected, the Mass Combi operates in “Charger Only mode”, see section 4.2.3	Auto	Auto, Charger
Shore Fuse	Limitation of the AC-input current when “Input Select” is set to “Shore” ( <i>Power Sharing</i> setting)	25A	6A, 10A, 16A, 25A
Input Select	Selection of the AC-input source. When set to “Shore”, the AC-input current is limited by the “Shore Fuse” setting. When set to “Generator”, the AC-input current is limited by the “Generator limit” setting; see section 8.3.2, <b>Extra settings</b> .	Shore	Shore, Generator
<b>State</b>			
State	Shows the state of the Mass Combi, i.e. “Inverting”, “Charging” or “Stand-by”.		(read only)
Load	<i>Charger mode</i> : Displays the DC charge current as a percentage of the maximum current <i>Inverter mode</i> : Displays the AC power as a percentage of the nominal inverter power		(read only)
<b>Charger</b>			
Charge state	Status of the battery charger (“Bulk”, “Absorption” or “Float”)		(read only)

Value	Meaning	Default	Adjustable range
DC Voltage	Battery voltage		(read only)
DC Current	Positive value: charge current Negative value: inverter current		(read only)
<b>AC Input</b>			
AC Input	Voltage at the AC input of the Mass Combi		(read only)
AC Input	Input current at the AC input of the Mass Combi		(read only)
<b>AC Output</b>			
AC Output	AC voltage at the <i>Short Break</i> output of the Mass Combi		(read only)
AC Output	Total AC output current of the Mass Combi		(read only)

### 8.3.2 Configuration

Below parameters can be changed via the MasterBus network by means of a remote control panel or by means of an interface connected to a PC with MasterAdjust software. See applicable user's manuals for details.

Value	Meaning	Default	Adjustable. range
<b>Serial interface</b>			
Language	Language that is displayed on a monitoring device connected to the <i>MasterBus</i> .	English	English, Nederlands, Deutsch, Français, Castellano, Italiano, Norsk, Svenska
Device	Model name (Combi 12/250, 24/2500, 48/2500, 48/7000)	Model dependent	(read only)
Device name	Name of this particular device in MasterBus. This name will be recognized by all devices that are connected to the <i>MasterBus</i> network.	Mass Combi	All names with a maximum of 16 characters.
<b>Bulk settings</b>			
Max. current	Maximum output current of the battery charger	I-max	0.1A – I-max
Bulk voltage	Maximum Bulk voltage	14.40/28.80/57.60V	8-16.00/16-32.00/32-64.00V
Bulk time	Minimum time that the charger stays in Bulk mode	4 min	1-255 min
Bulk return time	Delay time before charger switches to Absorption mode after reaching maximum Bulk voltage	30 sec	1-255 sec
<b>Absorption</b>			
Abs. voltage	Absorption voltage	14.25/28.50V	8-16.00/16-32.00/32-64.00V
Max absorp.time	Maximum time that the charger stays in absorption mode	360 min	1-65535 min
Min absorp.time	Minimum time that the charger stays in absorption mode	45 min	0-255 min
<b>Float settings</b>			
Float voltage	Float voltage	13.25/26.50/53.0V	8-16.00/16-32.00/32-64.00V
Forced float vo.	Forced float voltage (Constant voltage charging)	13.25/26.50/53.0V	8-16.00/16-32.00/32-64.00V
<b>Alarm settings</b>			
DC Alarm high on	Alarm DC High on (see section 3.6)	15.00/31.00/62.00V	8-16.00/16-32.00/32-64.00V
DC Alarm high off	Alarm DC High off (see section 3.6)	14.50/29.50/59.00V	8-16.00/16-32.00/32-64.00V
DC Alarm low on	Alarm DC low on (see section 3.6)	10.00/19.00/38.00V	8-16.00/16-32.00/32-64.00V
DC Alarm low off	Alarm DC low off (see section 3.6)	11.00/22.00/44.00V	8-16.00/16-32.00/32-64.00V
DC Alarm delay	Alarm delay time (see section 3.6)	30 sec	1-255 sec
All error	Alarm function will be triggered by all errors	Off	Off, On

Value	Meaning	Default	Adjustable. range
Battery voltage	Alarm function will be triggered by battery voltage error	On	Off, On
AC Output	Alarm function will be triggered by AC output voltage error	Off	Off, On
AC Load	Alarm function will be triggered AC output current error	Off	Off, On
Load level	Threshold value for "AC Load" error	8.7A	0.1A-25.5A
<b>Extra settings</b>			
Bulk ret. volt	Battery voltage at which charger returns to Bulk mode	12.80/25.60/51.20V	8-16.00/16-32.00/32-64.00V
Return amps	Return amps (% of maximum charge current)	6.0A/3.6A/1.8A	0.1A-25.5A
Temp compensat	Temperature compensation for charge voltage	0.03/0.06/0.12 V/°C	(read only)
Gel compensate	Float voltage compensation for gel setting	0.55/1.10V/2.20V	(read only)
Inverter voltage	AC Output voltage of the inverter	230V	180-250V
Generator limit	Limitation of the AC-input current when "Input Select" is set to "Generator" ( <i>Power Sharing</i> setting)	25A	1-25A
<b>Jumpers</b>			
Parallel mode	DIP switch A1 + A2: Parallel mode	See section 6.1.1	(read only)
Inverter freq.	DIP switch A3: Output frequency inverter	See section 6.1.2	(read only)
Energy mode	DIP switch A4 + A5: Energy saving mode	See section 6.1.3	(read only)
Battery Type	DIP switch A6 + A7: Battery type	See section 6.1.4	(read only)
Ground relay	DIP switch A8: Ground relay	See section 6.1.5	(read only)
Power Sharing	DIP switch B1 + B2 + B3: Power sharing function	See section 6.2.1	(read only)
Power support	DIP switch B4: Power Support Function	See section 6.2.2	(read only)
Mains support	DIP switch B5: Generator / mains support function	See section 6.2.3	(read only)
Power quality	DIP switch B6: Setting for Power Quality at incoming AC	See section 6.2.4	(read only)
Equalize	DIP switch B8: Equalize mode	See section 6.2.6	(read only)
<b>Events</b>			
Event x source	<i>Event-based command</i> Event by the Mass Combi that should result in an action by one of the other devices on the <i>MasterBus</i> network.	Disabled	(See List of event sources, section 8.3.3)
Event x target	<i>Event-based command</i> Selection of device on the <i>MasterBus</i> network that should take action due to an event by the Mass Combi.		(See Device list)
Event x command	<i>Event-based command</i> Action to be taken by the selected device.		(See <i>List of event commands</i> in the manual of the selected device.)
Event x data	<i>Event-based command</i> Value of the action to be taken by the selected device.		(See <i>List of event commands</i> in the manual of the selected device.)

### 8.3.3 List of list of events sources

Below the list of event sources of the *Mass Combi* is shown. These event sources can be used to initiate an event command and an event action at an other device that is connected to the *MasterBus*.

Event source	Description
Disabled	(no event programmed)
Charging	The Mass Combi is in Charge mode
Inverting	The Mass Combi is in Inverter mode

### 8.3.4 List of list of event commands

Below is shown the list of event commands and event data of the *Mass Combi*. Other devices connected to the MasterBus can be programmed to initiate these commands and actions at the *Mass Combi*.

Event command	Event data	Description
Input select	On	The AC-input current will be limited by the "Generator limit" setting; see section 8.3.1, "Input Select"
	Off	The AC-input current will be limited by the "Shore Fuse" setting
	Toggle	Limitation of the AC-input current toggles between "Generator limit" and "Shore Fuse"
	Copy Invert	If the <i>Event Source</i> switches to "On", the AC-input current will be limited by the "Shore Fuse" setting; If the <i>Event Source</i> switches to "Off", the AC-input current will be limited by the "Generator limit" setting.
	Copy	If the <i>Event Source</i> switches to "On", the AC-input current will be limited by the "Generator limit" setting; If the <i>Event Source</i> switches to "Off", the AC-input current will be limited by the "Shore Fuse" setting.
Mode	On	Operation mode of the Mass Combi will be set to "Auto", see section 8.3.1, "Mode"
	Off	Operation mode of the Mass Combi will be set to "Charger".
	Toggle	Operation mode of the Mass Combi toggles between "Auto" and "Charger"
	Copy Invert	If the <i>Event Source</i> switches to "On", the Operation mode of the Mass Combi will be set to "Charger"; If the <i>Event Source</i> switches to "Off", the Operation mode of the Mass Combi will be set to "Auto".
	Copy	If the <i>Event Source</i> switches to "On", the Operation mode of the Mass Combi will be set to "Auto"; If the <i>Event Source</i> switches to "Off", the Operation mode of the Mass Combi will be set to "Charger".

## 9 TROUBLE SHOOTING

### 9.1 FAULT INDICATORS

If a failure occurs, the origin of the failure is displayed by means of the LEDs at the front of the Mass Combi.

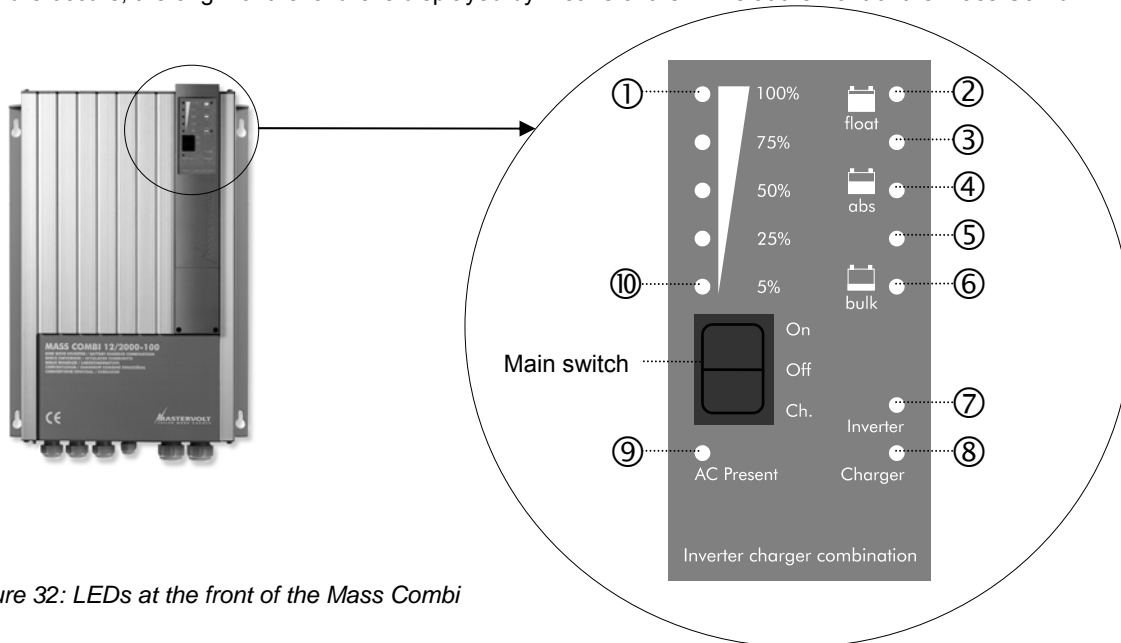

Figure 32: LEDs at the front of the Mass Combi

Mode	Illuminating LEDs	Explanation / Possible cause	What to do
--	None	The Mass Combi is switched off manually.	Switch on the Mass Combi by means of the On/Off/Ch. –switch. Also check the on/off switch of the ICC remote panel
		DC-fuse is blown	Investigate the cause of the failure and replace the fuse.
	9 = solid green, all other LED's = off	External AC is present, but the Mass Combi is switched off by means of a remote panel	Switch on the Mass Combi by means of the remote panel
	7 = solid green 8 = flashing fast red 9 = flashing fast green	Thermal fuse is blown.	Reset the thermal fuse. See 4.3.1.
	7 = solid green 9 = flashing fast green	Insufficient quality of AC-in (Shore or Generator)	Check AC wiring (Too thin and/or too long cables) Check the generator (if applied), or change setting for Power Quality at incoming AC (see section 6.2.4).
	7 = solid red 9 = solid green	AC-in from Shore or Generator connected to the Short Break output.	Disconnect the AC-in cable from the Short break output.
	7 = solid green 9 = solid green	Power support mode or Generator / Mains support mode active	No error
Charger	2 = solid yellow 8 = solid red	Temperature Compensation (TC) error. The temperature sensor on the battery gives an incorrect value.	Disconnect the sensor and if the LED's go off then replace the battery temperature sensor.
	3 = solid yellow 8 = solid red	DC voltage error. The battery voltage is too high or too low.	Check the batteries.

Mode	Illuminating LEDs	Explanation / Possible cause	What to do
	4 = solid yellow 8 = solid red	Short circuit error. The battery voltage is far too low. The charger reduces the output current till 25% of the maximum output current.	Check the batteries and the wiring.
	5 = solid yellow 8 = solid red	Overheating error. The charger current is reduced to zero in case of extreme overheating until the Mass Combi is cooled down.	Check whether the air flow of the Mass combi is blocked or whether the ambient temperature is too high.
	2,3,4,5,6 = blinking yellow, 8,9 = solid green	Equalizing mode is activated	See chapter 6.2.6
	2 = blinking yellow 3,4,5,6 = solid yellow 8,9 = solid green	Charger runs a compensation cycle for self discharge of the batteries	Nothing. See figure 28 for charging characteristics
Inverter	1 = solid yellow 7 = solid red	Overload error. The inverter is loaded with more than 2500W	Reduce the connected load by switching off some equipment.
	3 = solid yellow 7 = solid red	DC voltage error. The battery voltage is too high or too low.	Check the batteries and the wiring.
	4 = solid yellow 7 = solid red	The inverter output voltage is less than 180V AC.	Reduce the connected load.
	5 = solid yellow 7 = solid red	Overheating error. The inverter is off because of high temperature.	Reduce the connected load and let the Mass Combi cool down.
	7 = flashing red	The inverter is permanently off until a manual reset by means of the main switch.	Disconnect all loads and restart the Mass Combi by switching the unit manually off and on with the main switch.
	6 = flashing yellow 7 = solid green	The battery voltage is running too low, but the inverter is still on.	Check the batteries. The inverter will switch off if the battery voltage stays low
	3,4,5,6 = solid yellow 7 = solid green 2 = flashing yellow	The battery voltage is running too high, but the inverter is still on.	Check the DC-input voltage. The inverter will switch off if the battery voltage rises too high

Table 4: Failure codes of the Mass Combi.

If you cannot solve a problem with the aid of this table, contact your local Mastervolt Service Centre. See [www.mastervolt.com](http://www.mastervolt.com). Make sure you have the following information present if you have to contact your local Mastervolt Service Center to solve a problem:

Article and serial number (See section 1.6)

Software version (See section 9.2)



## 9.2 SOFTWARE VERSION

The version of the installed software can be derived from the illuminating LED's on the front panel during start-up. The LED's at the left hand side represent the software version of the electronics at the AC side, while the LED's at the right hand side represent the software version of the DC side of the combi.

Proceed as follows:

- Set the main switch of the Mass Combi to the "On"-position.
- All indicators are illuminated for a second.
- Then the LED's are showing the version number of the software by flashing. Flashing one time stands for 1, flashing two times stands for 2, and so on. See example below. Here the software version of the of the electronics at the AC side is 2.05; the software version of the DC side is 1.32:
- After showing the installed software versions the Mass Combi will switch on.

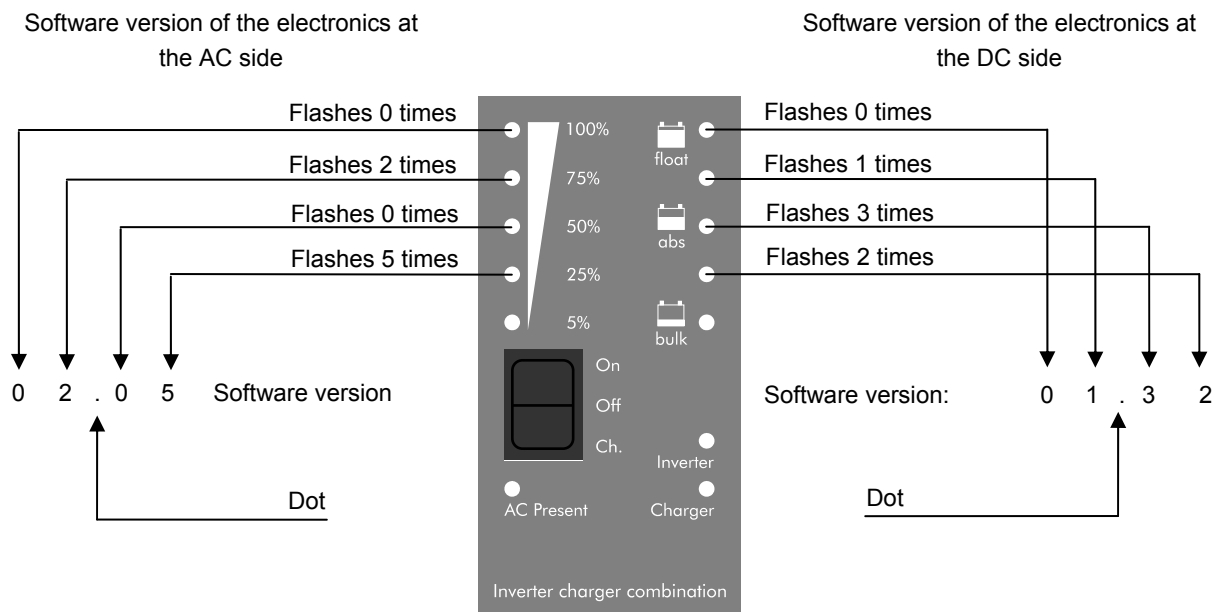

Figure 33: Representation of the software versions of the Mass Combi

## 10 TECHNICAL DATA

### 10.1 SPECIFICATIONS INVERTER

Model Mass Combi Partnumber	12/2500-100 36012505	24/2500-60 36022505	48/2500-35 36042505	48/5000-70 36045005
<b>DC input</b>				
Nominal battery voltage	12V	24V	48V	48V
Operating input voltage range	10.0 – 15.0V	19.0 – 31.0V	40.0 – 63V	40.0 – 63V
Absolute maximum voltage range (No defects)	0.0 – 16.0V	0.0 – 32.0 V	0.0 – 65V	0.0 – 65V
Low battery switch off* (1-30 sec delay)	10.0V ±5%	19.0V ±5%	40V ±5%	40V ±5%
Low battery switch on*	11.0V ±5%	22.0V ±5%	44V ±5%	44V ±5%
High battery switch off* (No delay)	15.0V ±5%	31.0V ±5%	63V ±5%	63V ±5%
High battery switch on*	14.5V ±5%	29.5V ±5%	62V ±5%	62V ±5%
Max. ripple allowed on DC (No defects)	5 % RMS	5 % RMS	5 % RMS	5 % RMS
Nominal current at full load	200A	100A	50A	100A
Maximum peak current	400A	200A	100A	200A
Recommended Fuse	250A	125A	80A	160A
Wire size (up to 2m/6ft)	2x 70mm <sup>2</sup> / AWG2/0	2x 50mm <sup>2</sup> / AWG0	2x 35mm <sup>2</sup> / AWG2	2x 50mm <sup>2</sup> / AWG0
Recommended batteries	200~600Ah	100~300Ah	100~300Ah	200~600Ah
<b>DC No load power consumption</b>				
Off mode	0mA	0mA	0mA	0mA
High power mode 230V / 0A out	< 9W	< 9W	< 12W	< 12W
Economic mode, 208V / 0A out	< 8W	< 8W	< 10W	< 10W
Idle mode, 5 pulses per 2½ sec	< 0,5W	< 0,5W	< 0,5W	< 0,5W
<b>AC output</b>				
Nominal voltage (±5%)	230VAC (180– 250VAC)*			
Wave form	True sine wave, max 5% distortion, 2½% typical			
Frequency	50Hz/60Hz +/- 0.05% (adjustable by DIP switch)			
Maximum continuous output power (AC-out: 230V, resistive load)				
- At 25°C / 77°F ambient temperature	2500VA (DC-in ≥11.0V)	2500VA (DC-in ≥22.0V)	2500VA (DC-in ≥48V)	5000VA (DC-in ≥48.0V)
- At 40°C / 104°F ambient temperature	2000VA (DC-in ≥11.0V)	2000VA (DC-in ≥22.0V)	2000VA (DC-in ≥48.0V)	4000VA (DC-in ≥48.0V)
Output power vs. ambient temperature	>25°C / 77°F derating –0.65% per °C / –1.15% per °F, Shutdown at 80°C / 176°F internal temperature.			
Surge capability (5 sec, resistive load)	4000W	4000W	4000W	7500W
Efficiency (100VA up to 2500VA)	≥90%			
Load power factor range	All power factors allowed			
Protections	Over temperature, overload, short circuit, AC on output, high battery, low battery.			

\* adjustable by means of MasterAdjust software

**10.2 SPECIFICATIONS CHARGER**

<b>Model Mass Combi</b>	<b>12/2500-100</b>	<b>24/2500-60</b>	<b>48/2500-35</b>	<b>48/5000-70</b>
<b>AC input</b>				
Nominal voltage / frequency	230V 50/60Hz	230V 50/60Hz	230V 50/60Hz	230V 50/60Hz
Input voltage, 100 % output	207 ... 265VAC	207 ... 265VAC	207 ... 265VAC	207 ... 265VAC
Input voltage, reduced output power	180 ... 207VAC	180 ... 207VAC	180 ... 207VAC	180 ... 207VAC
Absolute maximum voltage range	0 ... 265VAC	0 ... 265VAC	0 ... 265VAC	0 ... 265VAC
Input frequency range	45 ... 65Hz	45 ... 65Hz	45 ... 65Hz	45 ... 65Hz
Absolute maximum frequency range	0 ... 70Hz	0 ... 70Hz	0 ... 70Hz	0 ... 70Hz
Nominal input current (@230V)	7.2 A	8.5 A	8.5 A	17 A
Input phase	Single phase, 3 wire system		Single phase, 3 wire system	
Insulation class	Class I	Class I	Class I	Class I
Power factor	> 0,98	> 0,98	> 0,98	> 0,98
Harmonic distortion THD	3%	3%	3%	3%
Efficiency at full output	> 85%	> 85%	> 85%	> 85%
No-load power consumption	< 15W	< 15W	< 15W	< 30W

<b>Model Mass Combi</b>	<b>12/2500-100</b>	<b>24/2500-60</b>	<b>48/2500-35</b>	<b>48/5000-70</b>
<b>DC output</b>				
Nominal output voltage	12VDC (0...15.5VDC)*	24VDC (0...31.0VDC)*	48VDC (0...62VDC)*	48VDC (0...62VDC)*
Max. total output current	100A @ U ≤ 14,25VDC	60A @ U ≤ 28,5VDC	35A @ U ≤ 57VDC	70A @ U ≤ 57VDC
Second charge output:	5A	5A	No	No
Charge characteristic	Three stage, fully automatic, IUoUo, Equalize			
Equalize mode, output current:	10A	6A	5A	12A
Equalize mode, max. output voltage:	15,5VDC	31.0VDC	62VDC	31.0VDC
Equalize mode, maximum duration:	6 hrs.	6 hrs.	6 hrs.	6 hrs.

<b>Model Mass Combi</b>	<b>12/2500-100</b>	<b>24/2500-60</b>	<b>48/2500-35</b>	<b>48/5000-70</b>
<b>Factory settings</b>				
Return Amps*	6% of maximum output current		6% of maximum output current	
Max bulk, abs timer*	6 hours	6 hours	6 hours	6 hours
Return amps timer*	15 minutes	15 minutes	15 minutes	15 minutes
Return to bulk delay time*	30 seconds	30 seconds	30 seconds	30 seconds
Battery temperature compensation	-30mV per °C / -17mV per °F		-60mV per °C / -33mV per °F	
Battery voltage sense	automatic voltage compensation			
Protections	Short circuit (current is reduced to 25% of I-max)			

<b>Battery types</b>	<b>Acid</b>	<b>Gel AGM/ Spiral</b>	<b>Traction **</b>
Bulk	14.40V / 28.80V / 57,6V	14.40V / 28.8V / 57,6V	14.60V / 29.20V / 58,4
Charge voltage Absorption*	14.25V / 28,50V / 57V	14.25V / 28.50V / 57V	14.45V / 28.90V / 57,8
Charge voltage Float*	13.25V / 26.50V / 53V	13.80V / 27.20V / 54,4	13.25V / 26.50V / 53
Forced to Float	13.25V / 26.50V / 53V	13.80V / 27.20V / 54,4	13.25V / 26.50V / 53

\* adjustable by means of MasterAdjust software.

\*\* traction max ABS/BULK time + 120min.

### 10.3 MISCELLANEOUS

#### Switch over system

AC transfer fuse	Yes, by means of resetable fuse
Reverse polarity protection	None.
Overheat protection	Yes, derating above 80°C / 176°F on Power Heat sink
Type of Transfer	Automatic
Type of Switch	2 pole relay
Continuous rating	25A @ 230V
Transfer speed	25ms max, 10ms typical
Inverter synchronized to line before transfer	Yes.
Transfer (interruptible free)	Half seamless.
Power sharing mode	Yes, adjustable via DIP-switches, see 6.2, or via the remote APC.
Ground relay	Ground relay included for connection of neutral of inverter to ground only at inverter mode. Standard disabled. See chapter to 6.1.5 to enable.
AC cable size IN & OUTPUT	2,5mm <sup>2</sup> – 6 mm <sup>2</sup> (Depending on your electrical installation)
Battery connections	Bolt M8 (13mm diameter).
Slave charger output 5 amps	Faston, is switched off in inverter mode

<b>Model Mass Combi</b>	<b>12/2500-100</b>	<b>24/2500-60</b>	<b>48/2500-35</b>	<b>48/5000-70</b>
<b>Environmental Specifications</b>				
Max dimensions (HxWxD)	496 x 318 x 156 mm	496 x 318 x 156 mm	496 x 318 x 156 mm	496 x 318 x 279 mm
Weight	11kg / 24lbs	11kg / 24lbs	11kg / 24lbs	21kg / 46lbs
Operating temperature range	SPECIFIED, will meet specified tolerances. 0°C to 25 °C / 32 to 77°F			
	ALLOWED, may not meet specified tolerances. -25°C to 60°C / -13 to 140°F			
	NON-OPERATING, storage. -25°C to 85°C / -13 to 185°F			
Humidity	Max 95% relative humidity, not condensing.			
Environment class	IP 23			
Cooling	Mix of conventional and forced air cooling, by DC fans with variable speed.			
Fan operation	The fan does operate on a temperature current control related PWM variable speed control. DC maintenance free fan.			

**10.4 CHARACTERISTICS**

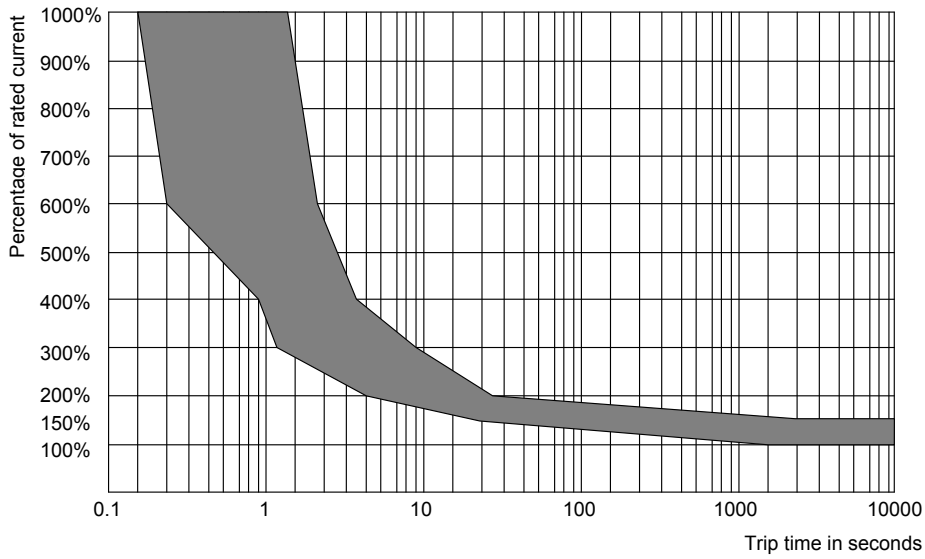

Figure 34: Switch off characteristic of the internal thermal fuse (@ 25°C / 77°F)

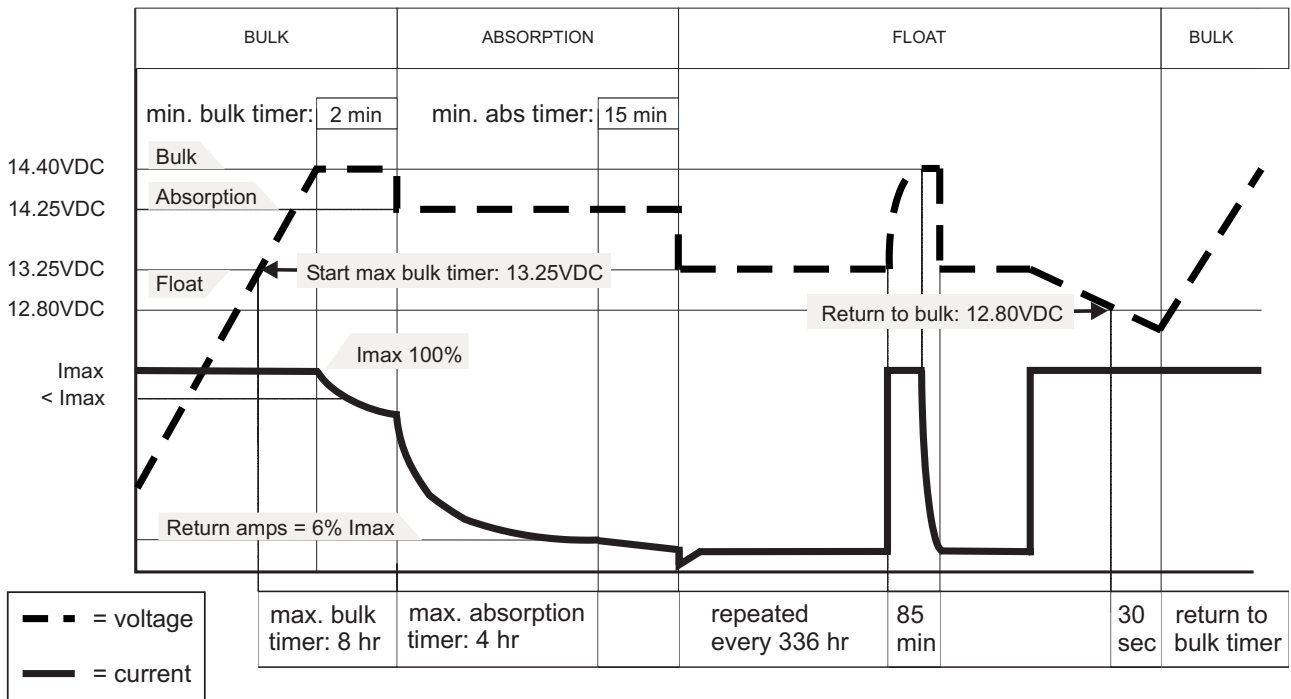

Figure 35: Charge characteristic of the three-step Plus charging method for the 12V combi (@ 25°C / 77°F)

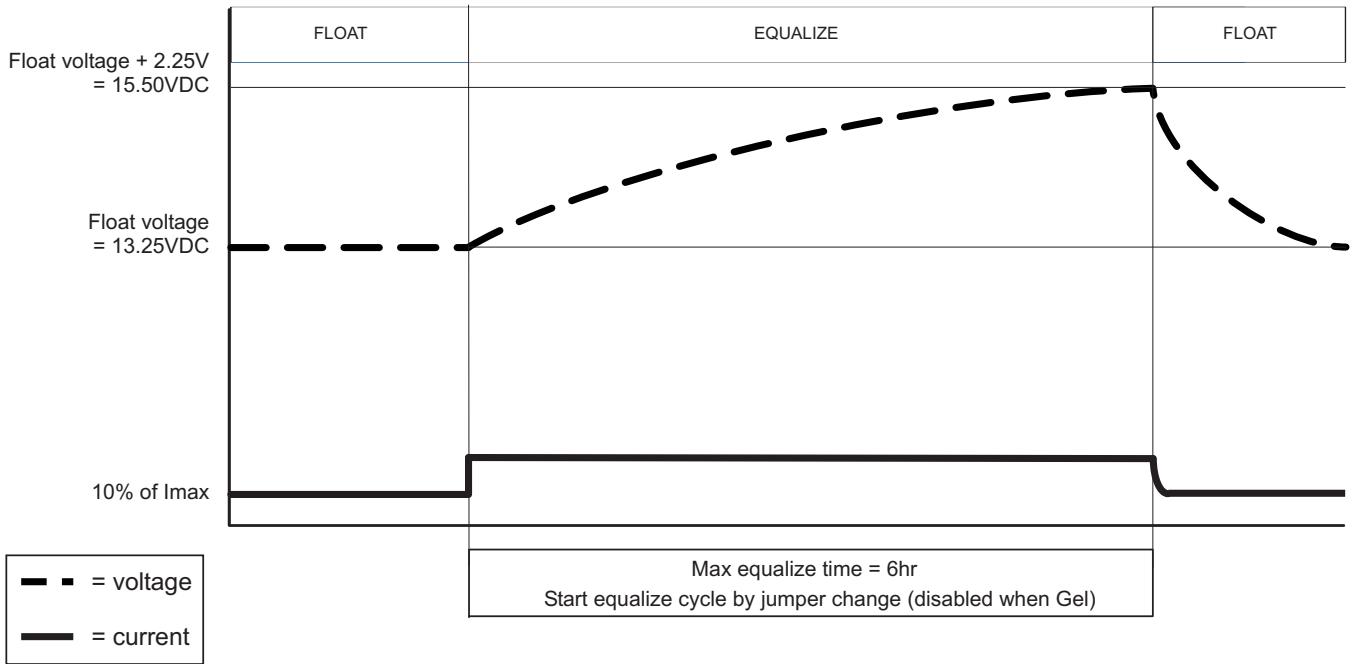

Figure 36: Charge characteristic of the equalize charge cycle, 12V Combi (see section 6.2.6) (@ 25°C / 77°F)

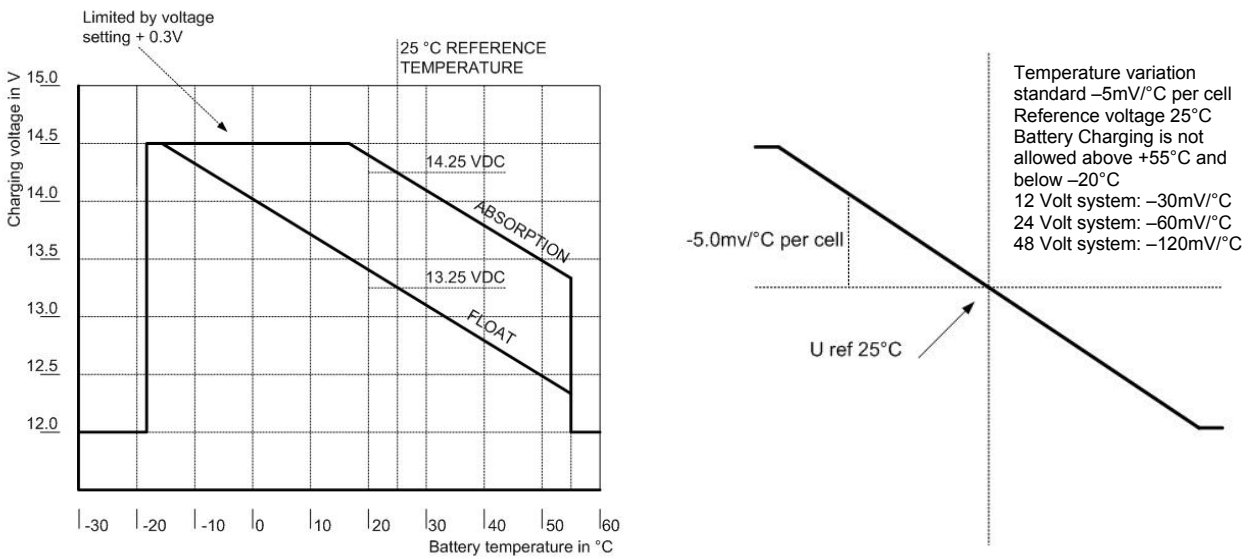

Figure 37: Temperature compensation characteristic (charge voltage versus temperature)

## 11 ORDERING INFORMATION

Part number	Description
6384012500	Industrial DC fuse 125A DIN 00
6384512500	Industrial DC fuse 125A DIN 1
6384525000	Industrial DC fuse 250A DIN 1
6384640000	Industrial DC fuse 400A DIN 2
6381001000	Fuse base DIN 00 (max. 160A)
6381002000	Fuse base DIN 1 (max. 250A)
6381003000	Fuse base DIN 2 (max. 400A)
79009006	Battery switch 250A with knob
79009005	Battery switch 250A with key
6502001030	Modular communication cable for connection of remote panels, cross wired, 6 pole, 6 meter / 19 ft
6502100100	Modular communication cable for connection of remote panels, cross wired, 6 pole, 10 meter / 33 ft
6502100150	Modular communication cable for connection of remote panels, cross wired, 6 pole, 15 meter / 49 ft
130010905	Modular communication cable for parallel operation, cross wired, 8 pole, 1 meter / 3 ft
130010906	Modular communication cable for parallel operation, cross wired, 8 pole, 5 meter / 16 ft
130010910	Modular communication cable for parallel operation, cross wired, 8 pole, 10 meter / 33 ft
130010915	Modular communication cable for parallel operation, cross wired, 8 pole, 15 meter / 49 ft
41500500*	Battery temperature sensor, incl. 6 meter / 19 ft cable
70405000	Inverter Charger Control (Remote ICC), See section 3.5.1
70405010	AC Power Control Panel (Remote APC) for 230VAC installations, See section 3.5.2
70603250	M-3-R1 Adapter for the mounting of a Remote ICC or APC in a Mastervision panel
70403080	Masterlink MICC, remote control panel for Mass Combi. Features: On/Off, status read out, Power Support, extended battery monitoring functions See section 3.5.3
77040000	MasterBus terminating device
77040020	MasterBus connection cable (UTP patch cable), 0,2m / 0.6ft
77040050	MasterBus connection cable (UTP patch cable), 0,5m / 1.6ft
77040100	MasterBus connection cable (UTP patch cable), 1,0m / 3.3ft
77040300	MasterBus connection cable (UTP patch cable), 3,0m / 10ft
77040600	MasterBus connection cable (UTP patch cable), 6,0m / 20ft
77041000	MasterBus connection cable (UTP patch cable), 10m / 33ft
77041500	MasterBus connection cable (UTP patch cable), 15m / 49ft
77042500	MasterBus connection cable (UTP patch cable), 25m / 82ft
77050100	100m / 330ft MasterBus cable (UTP cable)
77050200	50 pcs. modular jacks
77050000	Complete set to assemble UTP patch cables. Delivery includes: 100m / 330ft UTP cable, 50 pcs. modular jacks and crimping tool
77030100	MasterBus – USB interface, required as interface between your PC and the MasterBus when using MasterAdjust software.
77030400*	MasterBus – Serial interface
77010300	MasterView Easy, Touch screen to control and monitor all MasterBus products
77010400	MasterView System, Full-colour touch screen to control and monitor all MasterBus products
77020100	MasterShunt 500, DC-distribution module for exact readout of battery voltage, charge / discharge current, and state of charge. Continuous rating: 250A, peak current: 500A

\* These parts are standard included with the delivery of the Mass Combi 12/2500-100, 24/2500-60, 48/2500-35 and 48/5000-70

MasterVolt can offer a wide range of products for your electrical installation, including automatic AC transfer switches, remote control panels and DC distribution kits. See our website [www.mastervolt.com](http://www.mastervolt.com) for an extensive overview of all our products

## 12 EC DECLARATION OF CONFORMITY

Manufacturer Mastervolt  
Address Snijdersbergweg 93  
1105 AN Amsterdam  
The Netherlands



Herewith declares that:

Product:

36012505	Mass Combi 12/2500-100 / 230V
36022505	Mass Combi 24/2500-60 / 230V
36042505	Mass Combi 48/2500-35 / 230V
36045005	Mass Combi 48/5000-70 / 230V

Is in conformity with the following provisions of the EC

- 2004/108/EC (EMC directive). The following harmonized standards have been applied:
  - Generic emission standard: EN61000-6-3: 2007
  - Generic immunity standard: EN61000-6-1: 2007
- 2006/95/EC (Safety directive), with the following standard:
  - Low voltage standard: EN60950: 2000

Amsterdam,



P. F. Kenninck,  
C. E. O. Mastervolt.