

TALON

Shallow Water Anchor-Owner's Manual



MINN KOTA

TABLE OF CONTENTS

Introduction	3
Getting Started	4
Using Your Remote	4
Programming A New Remote	4
Using your Talon.....	6
Auto-Deploy/Retract	6
Auto-Drive.....	7
Depth Indication	8
Wave Absorption	9
Manual Retraction Procedure.....	9
Rough Water Mode.....	11
Cancelling Rough Water Mode	12
Deployment Notification Alarm	12
Retraction Notification Alarm	12
Removal/Storage.....	14
Service and Maintenance.....	16
Accessories	21
Frequently Asked Questions.....	24
Troubleshooting.....	29
Parts List	32
Compliance Statements	36
Warranty	38

INTRODUCTION

Overview

Thank you for purchasing the Minn Kota® Talon. This revolutionary shallow water anchor uses state-of-the-art technology to deliver unprecedented levels of boat control. Intuitive features and wireless control enable Talon to accurately position your boat and improve your bait presentation. Talon positions your boat for you, so you can focus on fishing. By following instructions in this manual, you will learn how to properly install and operate your new Talon for years of trouble free use. We encourage you to read this manual thoroughly in order to maximize your product experience.

Safety and Cautions

You are responsible for the safe and prudent operation of your vessel. We have designed Talon to be an accurate and reliable tool that will enhance boat control and improve your ability to catch fish. This product does not relieve you from the responsibility for safe operation of your boat. You must avoid hazards to anchoring and always maintain a permanent watch so you can respond to situations as they develop.

Caution: Never leave the boat unattended with the Talon as your only boat anchor. Talon is not intended to provide primary anchorage.

Talon Registration Card





To receive all the benefits of your product warranty please fill out and mail the registration card, you may also register your product online at minnkotamotors.com.



USING YOUR REMOTE

Your Talon comes direct from the factory with two remotes pre-programmed to your unit. Each remote includes a lanyard that may be attached to either end of the remote to suit your preference. The remote has two buttons; UP and DOWN.









- 1. To Deploy:** Press the DOWN button  twice within ½ second.
- 2. To Retract:** Press the UP button  once.
- 3. To Stop:** Press the UP button  once or DOWN button  twice within ½ second.

Each remote uses a CR2032 size lithium coin cell battery. See page 14 for instructions on how to replace the battery.





PROGRAMMING A NEW REMOTE

Your Talon can store 10 total remote ID's. If 10 IDs have been learned to the Talon unit and an 11th remote is learned, the first ID learned will be overwritten with the 11th remote ID. The new remote will be learned, the oldest will be erased.

To learn a new remote ID:

1. Retract the anchor if it is not already retracted by pressing the Auto UP switch .
2. After the anchor has retracted, press and hold the Auto UP switch  on the Talon. A steady tone  will be heard.
3. While continuing to press the Auto UP switch , press the UP button  on the new remote one time.
4. A series of 3 beeps  will be heard, indicating the new remote has been learned.
5. Release the Auto UP switch  on the Talon after the 3 beeps begin.



To erase all stored remote IDs (this may require assistance from a second person):

1. Retract the anchor if it is not already retracted.
2. Disconnect the power cable white power lead from the battery.
3. Press and hold the Auto UP switch  on the Talon.
4. While continuing to press the Auto UP switch , reconnect the power cable white power lead to the battery.
5. A series of fast beeps will be heard and then a long steady tone .
6. Release the Auto UP switch  after the long steady tone has begun. All remote IDs are now erased.



USING YOUR TALON

Auto-Deploy/Retract

Deploy

Raising and lowering your Talon can be done wirelessly from anywhere in the boat using your remote or directly through the control panel. Two button presses (within 1 second) of the remote DOWN button  or one button press of the control panel Auto DOWN button  automatically deploys the anchor.

Retract

One button press of the remote UP button  or control panel Auto UP button  automatically raises the anchor to the retracted position. Talon shuts off automatically when completely retracted. There is no need to hold down a switch or button.





Auto-Drive

Talon's revolutionary Auto-Drive feature stops your boat with greater speed and precision than the competition. Two button presses (within 1 second) of the remote DOWN button  not only deploys your anchor automatically, but Talon actually drives the anchor in for you to ensure the anchor is seated. Talon's Auto-Drive deploy shuts the anchor off when the spike contacts the bottom. Auto-Drive will automatically power the spike into the bottom with three successive hits, using increasing force on each hit.

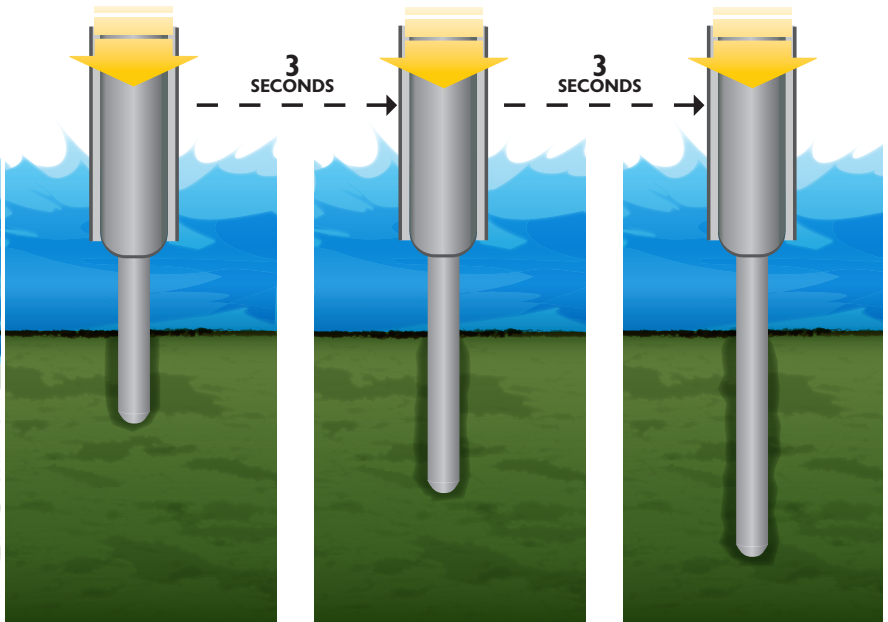

Depth Indication

Talon shows your deployed status of the anchor via the LED display on your control panel. High visibility LED's display one light for each foot of deployment from anywhere in the boat. Know the immediate status of your anchor, or deploy the Talon to a specific length for stopping during a drift.



1 LED per foot of depth of deployment



Wave Absorption

Talon enables your boat to move up or down without affecting the anchor. It uses a built-in floating suspension to keep your boat locked to the bottom, even in rough water conditions.

Manual Retraction Procedure

In the event of a power failure or other occurrence where the Talon cannot be retracted in the normal manner your Talon can be manually retracted.

Minn Kota recommends keeping a $\frac{7}{16}$ " socket and socket wrench in your boat, as they are required for the manual retraction procedure.

NOTE: Be sure to disconnect power BEFORE attempting this procedure!!

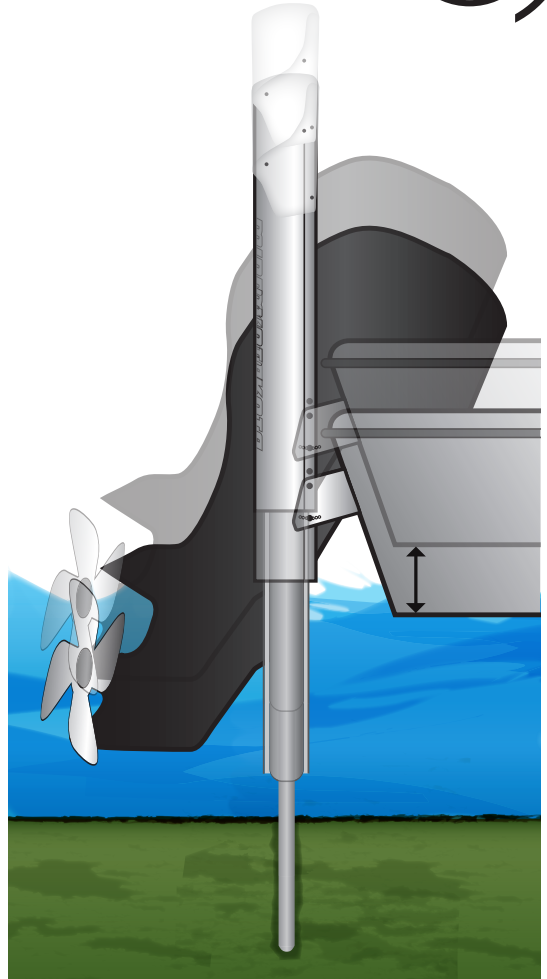



1. Remove power from the Talon by disconnecting the negative battery lead or turning the battery selector switch to OFF.

2. Place the $\frac{7}{16}$ socket wrench over the exposed hex.

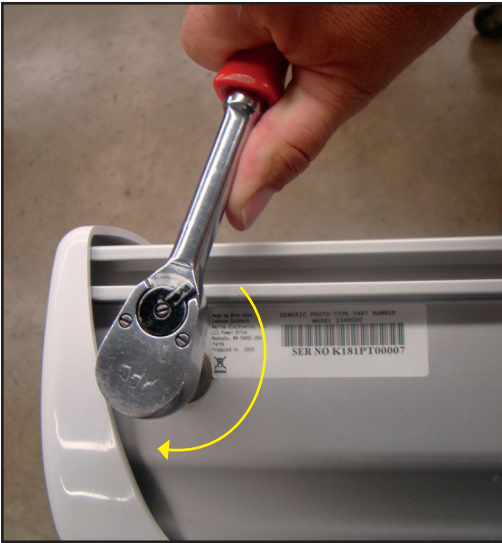

3. Crank the socket wrench in a clock-wise direction until the unit is fully retracted.

4. If this procedure does not retract the unit, you will need to remove the unit from the mounting bracket, by loosening the four $\frac{1}{2}$ " hex head bolts on the sides of the mounting bracket.





Rough Water Mode

For an even stronger hold, activate Rough Water Mode (RWM)  located on the control panel of Talon. In Rough Water Mode, Talon performs three Auto-Drive sequences at ten second intervals. At this point, the rough water mode sequence is complete, but remains active as indicated by the RWM indicator LED. RWM will not run again until you press the DOWN button  on the control panel, or double-click the DOWN button  on your remote.

This feature will automatically shut off after 60 minutes of no anchor activity from the time it was turned on. The Rough Water Mode button must be pushed again to turn the feature back on after this timeframe.



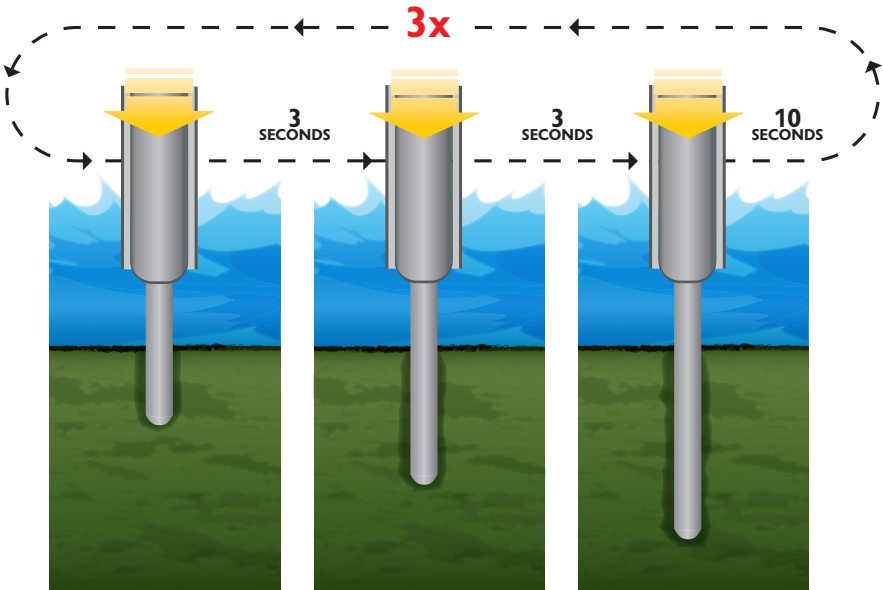

**NOTE: Rough Water Mode is NOT recommended for use in soft bottom structure.*



Sequence repeated 3 times during rough water mode.

Cancelling Rough Water Mode

Rough Water Mode can be cancelled two ways.

1. Depress the  button, thereby turning off the RWM indicator LED . This will cancel the rough water mode.
2. If the RWM is running a sequence, press the Auto UP button  on the control panel, or click the UP button  on the remote 1x. This will cancel the RWM sequence, but the RWM indicator LED will remain on.

Deployment Notification Alarm

Talon's Auto Alarm will emit a tone each time you turn the ignition key to the ON position if the anchor is not retracted. This alarm reminds you that your Talon is still deployed. Taking off with the Talon in the deployed position could cause damage to your anchor or boat which will not be covered by warranty. SEE PAGE 16 OF THE TALON INSTALLATION MANUAL TO PROPERLY SET UP THE DEPLOYMENT NOTIFICATION ALARM

*****PROPER SETUP OF THE DEPLOYMENT NOTIFICATION ALARM IS REQUIRED FOR YOUR WARRANTY AND IS CRITICAL FOR THE SAFETY OF YOUR BOAT AND THE TALON*****

Retraction Notification Alarm

Your Talon is equipped with a built-in retraction control alarm to protect the lift motor. If the lift capacity of the motor is exceeded -OR- the motor takes more than 10 seconds to retract, the motor will stop and notify you with a series of three triple beeps. (...-...-...)

The most common reasons for the Retraction Notification Alarm sounding are 1) because of an extremely soft or muddy bottom and the spike is deeply buried and cannot retract on its own, or 2) there may be an excessive amount of side load on the spike, generally due to fast moving water currents or wind.



If the Retraction Notification Alarm is emitted, the following steps should be taken to retract the anchor:

- 1.** Press the "UP" button  on the remote or control panel. If the anchor does not raise within two attempts;
- 2.** Loosen the spike from the bottom by CAREFULLY shifting the boat back and forth using the main engine power, then attempting to raise the anchor again. This is especially useful if you are fishing in a soft or muddy bottom structure.
- 3.** Remove any excessive side loads on the anchor as described above. This generally requires backing against the current (or direction of the load) then attempting to retract the anchor again with side loads removed.

Other reasons for the Retraction Notification Alarm may include:

- 1.** Battery power is low. This may induce a retraction time greater than 10 seconds.
- 2.** Obstructions on the anchor preventing it from retracting.

In the event the anchor cannot be retracted normally, please refer to page 9 of this booklet for the manual retraction procedure.

Removal and Storage

If needed, your Talon can be easily removed from the Transom Bracket.

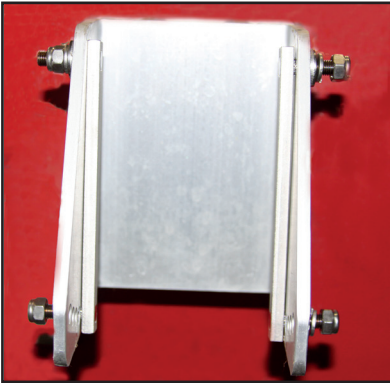

To remove:

- 1.** Prior to removal, first disconnect the power cables from the starting battery. Ensure the cable is disconnected and will not interfere with removal of the Anchor Assembly. If the Deployment Notification Alarm is being used, the user installed Alarm wire will have to be cut and re-spliced each time.

Note: You may need to loosen the Outboard Cable and Wire Harness to pass the power cable and Fuse Assembly back through the boot.

- 2.** Remove the wire ties holding the power cable.
- 3.** Ensure the power cable is free and clear prior to removing the anchor.
- 4.** Remove the lower stop nut from the bottom of the Talon starboard track. Be sure to store this in a safe location or place it back onto the Talon once it is removed from the mounting bracket.
- 5.** Loosen the 4 vertical adjustment nuts while supporting the Talon so it does not fall. Then slide the Talon up until it clears the tracks.

NOTE: A Quick Disconnect Plug accessory is available from Minn Kota to simplify the removal of the electrical connection when mounting and dismantling your Talon. For additional Talon accessories, see pages 21 thru 23.



6. Reconnect and tighten battery terminations.
7. Be sure to store the mounting hardware in a safe location or tighten the mounting straps to ensure they do not fall out.
8. **IMPORTANT:** *When reinstalling Talon, it is important to check tension of the 4 vertical adjustment nuts after initial use and periodically thereafter to ensure they are at the recommended torque of 20 - 30FT. LBS.*

For storage:

Rapid Removal Accessories:

If you intend to remove or adjust your Talon frequently, you might consider installing the following accessory kits: Quick Release Handle Kit (1810230) and Talon Quick Disconnect Plug (1810240). *Photos in Additional Accessories section.*

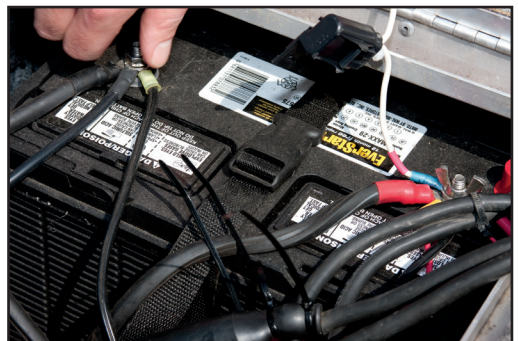

Remote Battery Replacement

- 1.** Make sure hands are clean, dry and static free. Discharge any static electricity by touching a metal object that is grounded.
**Static electricity can damage the circuit board.*
- 2.** With the remote upside down, remove the four case screws.
- 3.** Remove the bottom cover.
- 4.** Carefully remove the old battery from the battery holder and replace with a new one. The batteries snap in and out of the battery holder. Install the new battery with the positive (+) side facing up away from the circuit board. Use a name brand CR2032 lithium coin cell battery.
- 5.** Replace back cover and reinstall case screws. Do not over tighten case screws as this will damage the remote enclosure.

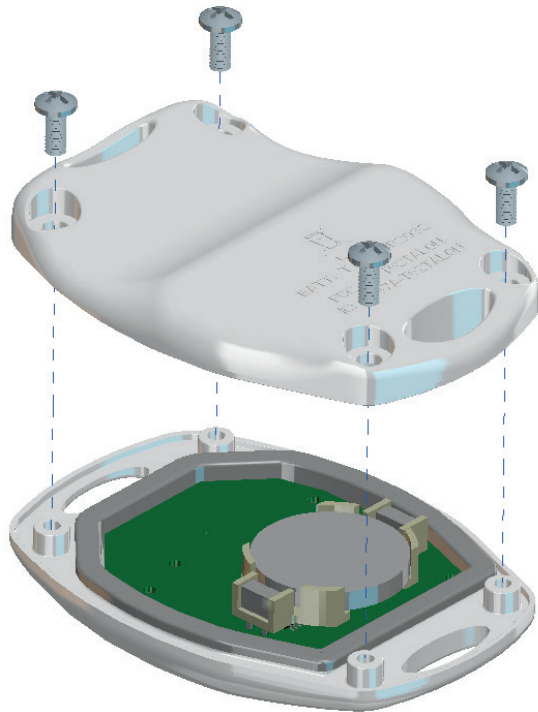



***IMPORTANT:** Check tension of the 4 vertical adjustment bolts after initial use and periodically thereafter to ensure they are at the recommended torque of 20 - 30FT. LBS.*

Cleaning the Unit

- Minn Kota recommends rinsing off the anchor after each use – especially in saltwater applications – to minimize residue build up on the anchor.
- At the top of the anchor assembly is a wash out port designed to flush out sand, silt, or other debris that may collect inside of the unit. A simple garden hose is sufficient for this purpose.
- As part of the routine cleaning and maintenance of your Talon, it is recommended that the lower roller assembly shown in the illustration below, be periodically lubricated to ensure long life and high performance. You may use any all purpose household lubricant (such as WD40) for this purpose.

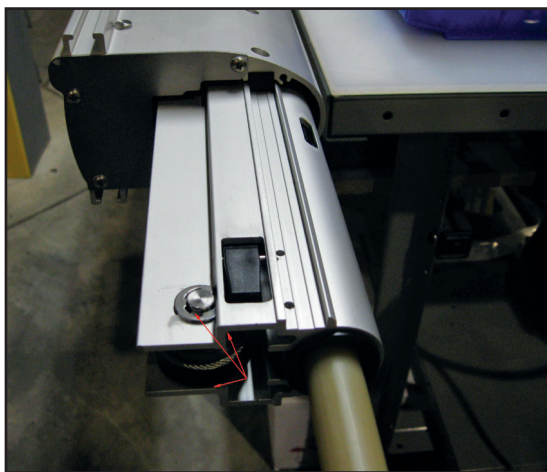

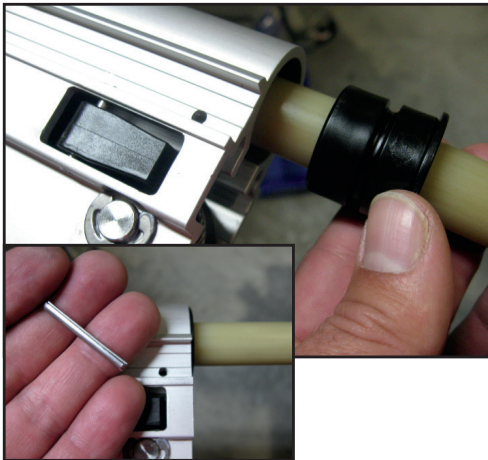
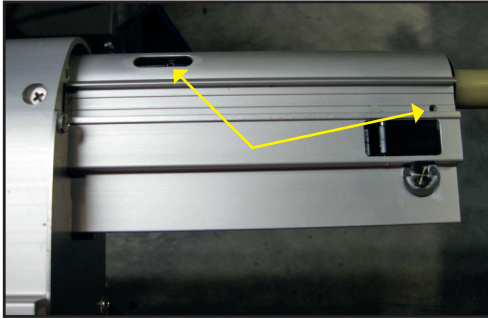
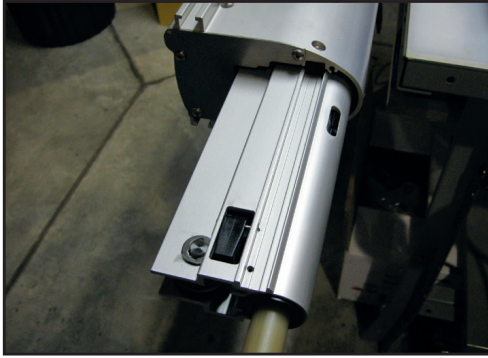

Replacing the Spike

- 1.** The spike for your Talon comes with a lifetime guarantee, with 2 years of labor covered for repair. See the warranty section of the manual for further details.
- 2.** If replacement of the spike is necessary in the field, the following steps should be taken.
 - a.** Extend the spike out so that the 2nd stage begins to exit the bottom of the anchor. This may require removing the anchor from the mounting bracket, and laying the anchor horizontally or on a flat surface.
 - b.** You will need to remove two retainer pins in order to replace the spike. First remove the spike isolator pin, and slide the spike isolator out from the bottom of the 2nd stage. Next, remove the spike retainer pin.



- c. Remove the spike from the anchor. (You will not need to retain the o-ring from the spike you are replacing. The new spike will include a replacement o-ring.)
- d. Place the new spike into position along with the replacement o-ring. When the spike is fully seated into the anchor, the o-ring should be slid up to the face of where the spike is held. Be sure to align the retainer groove on the spike with the retainer pin hole.
- f. Slide the spike isolator up the spike and into the 2nd stage. Carefully replace the spike isolator retainer pin.
- g. Carefully replace the spike retainer pin, making sure the ends of the pin are recessed on both sides.

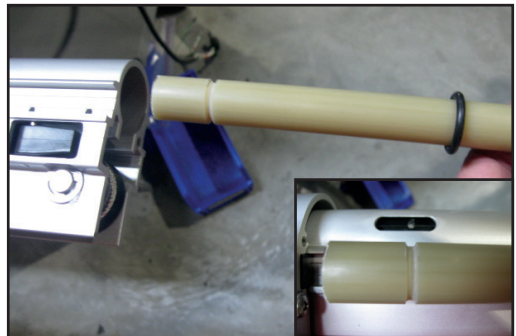
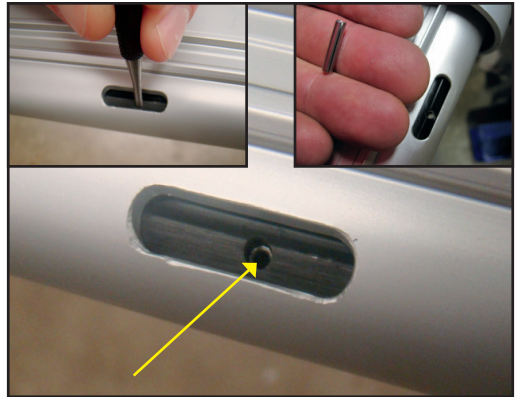

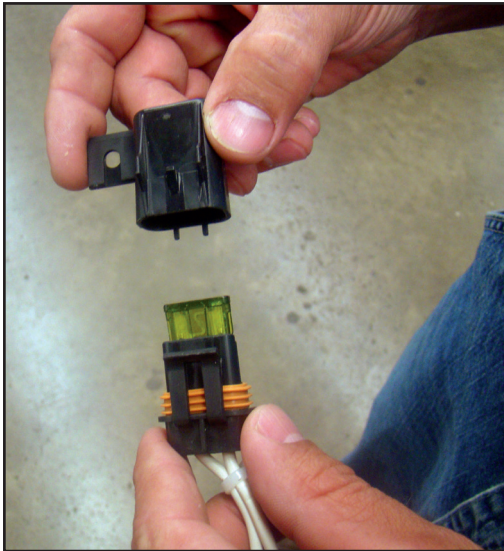

Fuse Replacement

To replace the 30A in-line fuse, the following steps should be taken. The 30A fuse is located 6" from the positive battery terminal.

- 1.** Remove the protective cap from the fuse holder, exposing the 30A blade fuse. (Replacement fuses are readily available at most auto parts stores)
- 2.** Pull the blade fuse out and replace with a new fuse. Be sure the fuse is fully seated.
- 3.** Replace the protective cap onto the fuse holder, making sure that the fuse holder cover snaps back on to ensure a watertight seal.



If you're not mounting Talon directly to the transom, you'll need one of our adapter plates to offset the unit from the back of the boat. For more information on adapter plate applications and purchasing, visit minnkotamotors.com.

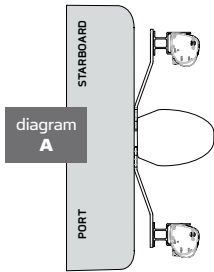

Adapter bracket between outboard and transom.

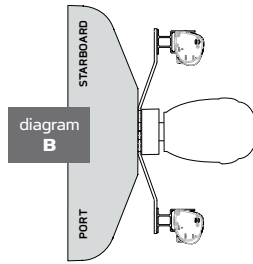

Adapter bracket between jackplate and transom.

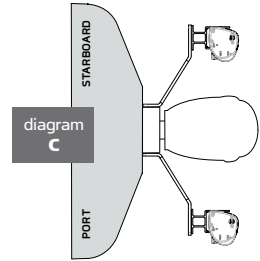

Adapter bracket to jackplate side mount.





Quick Release Handles 1810230 The Talon Quick Release Handles will allow you to quickly remove your Talon when not in use, and/or adjust the height of Talon without the use of hand tools.

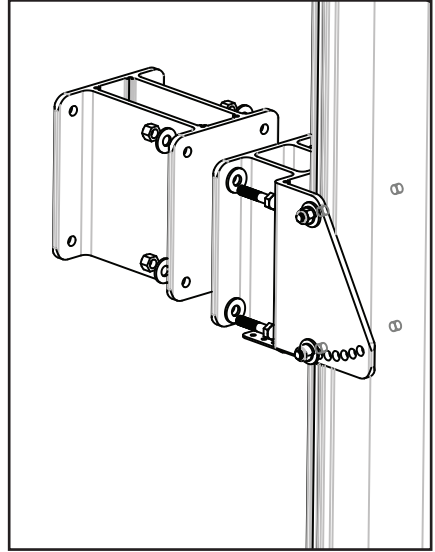

6" Riser 1810220 The Talon 6" Riser will give you additional set back clearance from the transom, such as when installing over top of trim tabs or other accessories.



Quick Disconnect Plug 1810240 The Talon Quick Disconnect Plug works well with the Quick Release Handles accessory for those that want to be able to easily remove and replace Talon for storage or security.

ADDITIONAL ACCESSORIES



2 Button Remote Accessory
1810250 (*Lanyard included*)



4 Button Remote Accessory
1810251 (*Lanyard included*)

The Talon 4 Button Remote is available for the avid angler that may choose to install 2 Talons on their boat. The 4 button remote offers the versatility of individually operating 2 Talons with a single remote.

FREQUENTLY ASKED QUESTIONS

Talon Features and Questions:

Q. Is the Talon completely battery operated?

A. Yes. The Minn Kota Talon is a mechanical design that is 100% electrically driven, so there is no messy hydraulic fluid and/or hoses to deal with.

Q. What is the difference between Wave Absorption vs. Rough Water Mode?

A. Wave absorption is a mechanical feature that is always present, and acts like a shock absorber for your Talon. As your boat moves up and down in moderate waves or chop, wave absorption will help keep the spike engaged with the bottom.

Rough Water Mode is a software feature that you can turn on and off as needed. When Rough Water Mode is turned on, the anchoring sequence (Auto-Drive) will repeat itself 3 times with 10 second delays between each sequence, and then stop until the user reinitiates the sequence by pressing down on the control panel or the remote.

Rough Water Mode will remain on until 1) the user manually turns it off at the control panel, or 2) 1 hour of inactivity passes.

Q. What is Auto-Drive?

A. Auto-Drive is a mechanical feature that powers the spike into the bottom 3 times in 9 seconds, using increasing force on each hit.

Q. Why do I want to be able to adjust the Talon up or down when mounting on my boat?

A. Each boat sits differently in the water, and has varying amounts of draft (hull under the water line). While Minn Kota recommends that the Talon mounting bracket be mounted as high up on the transom as possible, Minn Kota also recommends that the bottom of the Talon be a minimum of 4" up from the bottom line of the hull of your boat. Having this adjustability will minimize any spray that may occur while under way, and offer the greatest amount of stability to the Talon.

Q. When do I want to use the reverse angle on the bracket when mounting the Talon?

A. Some boat models have transoms that angle towards the inside of the boat. In these cases, the Talon quick release bracket can be inverted to account for this reversed angle without the hassle of shims.

Q. In the event that my anchor does not deploy, is there a way I can do it manually?

A. In the case where your Talon does not retract or deploy, we recommend referring to the trouble shooting section of your owners manual.

Q. Does the Talon have a fuse? What size is it? Where can I purchase the fuse?

A. Yes, the Talon has an in-line 30A blade style fuse. These can be purchased at any automotive parts store.

Q. How is the maximum deployment of the Talon measured?

A. From the bottom of the Talon to the tip of the spike when fully deployed.

Q. What is the overall length of the Talon when retracted?

A. The 6' Talon is 45" and the 8' Talon is 57".

Q. If I adjust the Talon extrusion lower to the water, do I gain more depth?

A. Yes. But the user must be aware that Minn Kota recommends a minimum of 4" up from the bottom of the hull line to minimize spray. Dragging the Talon thru the water while under way could cause damage to the Talon and/or the transom of your boat.

Q. How much force does the Talon have once the spike has made contact with the bottom?

A. The Talon anchors with up to 2 times more force than any other shallow water anchor on the market.

Q. How fast does the Talon deploy?

A. The 6' Talon will fully deploy in about 4 seconds. The 8' Talon will fully deploy in about 5 seconds.

Q. Where can I download a copy of the Talon Manual?

A. www.minnkotamotors.com

Rigging:

Q. Do I need a separate battery to operate the Talon?

A. No. Minn Kota recommends connecting your Talon to the starting/cranking battery of your boat.

Q. Can I install an electrical plug on the Talon lead wires?

A. Yes. Minn Kota offers a quick disconnect plug accessory specifically designed for the Minn Kota Talon.

Q. How do I determine where and how to mount the Talon?

A. This will vary from one boat to the next. It is important to check for proper steering and trimming clearances when laying out your installation. See the Talon installation manual for detailed instructions.

Q. Which side of the boat do I want to install the Talon?

A. Minn Kota recommends installing your Talon on the port (left) side of your boat in order to give you the maximum amount of clearance between the boat engine and the control panel of the Talon.

However, the Minn Kota Talon can be installed on either side of the boat.

Q. How do I mount the Talon when I have trim tabs?

- A. Talon requires a minimum of 6" of clearance from the mounting surface. If further clearance is required, or it is necessary to mount over top of trim tabs, Minn Kota offers a 6" riser accessory, and a variety of adapter plates that will give you the proper amount of setback (distance from the transom) to clear trim tabs, and/or other accessories.

Cordless Remote Control:

Q. Does the Remote float?

- A. Yes.

Q. Is the Cordless Remote waterproof? Is the Cordless remote saltwater protected?

- A. Yes. The Talon remote is water proof, and saltwater protected, but as with any electrical accessory, general care should be taken to prevent water intrusion.

Q. Can I use multiple Remotes on the Talon?

- A. Yes. You can learn up to 10 remotes to any single Talon. You can also learn 1 remote to multiple Talons.

Q. Where can I purchase additional Remotes?

- A. You can purchase a remote at any Minn Kota retailer.

Q. Does the Remote have a battery?

- A. Yes.

Q. What is the battery that goes in the Remote?

- A. Battery type: CR2032

Mounting Bracket Questions and Applications:

Q. How do I know when I should use a mounting bracket?

- A. Some boats have irregular shaped transoms and the standard Talon quick release mounting bracket cannot be mounted directly to the transom. In other cases there are other accessories such as trim tabs, transducers, poling platforms, etc. that may require additional clearance. Use the Minn Kota Talon Adapter Plate Selection Guide to select the proper application for your boat.

Pictures and dimensions:

Please visit www.minnkotamotors.com for more info.

GENERAL TROUBLESHOOTING

Problem: **My Talon doesn't always respond every time I press a button on my remote.**

Solution: If Talon is still completing an Auto-Drive or Rough Water Mode anchoring sequence when a button is pressed, the Talon may still be trying to complete the last command. A new command will cancel the last one and therefore may appear as unresponsive. Press the button again, or wait for Talon to complete the last command before pressing the button again.

Solution: Check the remote battery, and replace as needed.

Solution: Clear transmit path between remote and the Talon.

Problem: **My new remote won't work.**

Solution: Perform the learn sequence for a new remote.

Solution: Check the remote battery and replace as needed.

Solution: Confirm that your power connections are good, and that you have sufficient battery power.

Problem: **My Talon won't respond to any button presses on the remote or on the control panel.**

Solution: Make sure that your battery connection is solid, and that the battery is fully charged.

Problem: Retraction Notification Alarm keeps sounding, and I am unable to retract my anchor by normal operating procedures.

Solution: Are you fishing in very muddy waters? Your Talon may be driving the spike very deep into the muck, and is drawing more than the usual amount of current to pull the spike out. It is recommended that Rough Water Mode not be used in soft bottom conditions. See page 12 of this manual for more details on how to retract Talon when the Retraction Notification Alarm sounds.

Problem: My Talon is stuck in the down position, and I cannot see any depth LEDs on the control panel.

Solution: Check to see if the 30A fuse is blown, and replace as needed.

Solution: Confirm that your power connections are good, and that you have sufficient battery power.

Solution: If these don't address the problem, use the manual retract procedure to retract the Talon as described in your owner's manual. Or remove the Talon from the transom mounting bracket.

Problem: My Talon is stuck in the down position, and I can still see depth LEDs on the control panel.

Solution: The Retraction Notification Alarm should sound when you attempt to retract Talon. See page 12 of this manual for more details on how to retract Talon when the Retraction Notification Alarm sounds.

Problem: The manual retract procedure won't work, and I am still stuck in the down position.

Solution: If the manual retract procedure will not retract the Talon, then you will need to remove the Talon from the transom mounting bracket, by loosening the (4) ½" hex head bolts on the sides of the transom mounting bracket. Be careful not to lose the hardware for mounting the Talon to the transom mounting bracket.

Problem: My Talon is making a grinding noise when retracting and deploying.

Solution: You may have sand or silt build up inside. Use a garden hose in the top washout port to flush out any debris that may be causing this. If you're fishing in saltwater, it is a good idea to rinse out the unit on a regular basis to prevent this kind of build up.

Problem: I cannot see the depth indicator LED's.

Solution: Confirm that your power connections are good, and that you have sufficient battery power.

Problem: My depth finder says I'm in 4 feet of water, but my Talon shows more or less than 4 LED's. What's wrong?

Solution: Remember that Talon is an anchor, not a depth finder. The indicator LED's on Talon are for reference only, and should not be used to determine actual depth. They merely represent approximate depth of deployment of the Talon.

PARTS LIST VIEW

See Parts List on
Pages 34-35

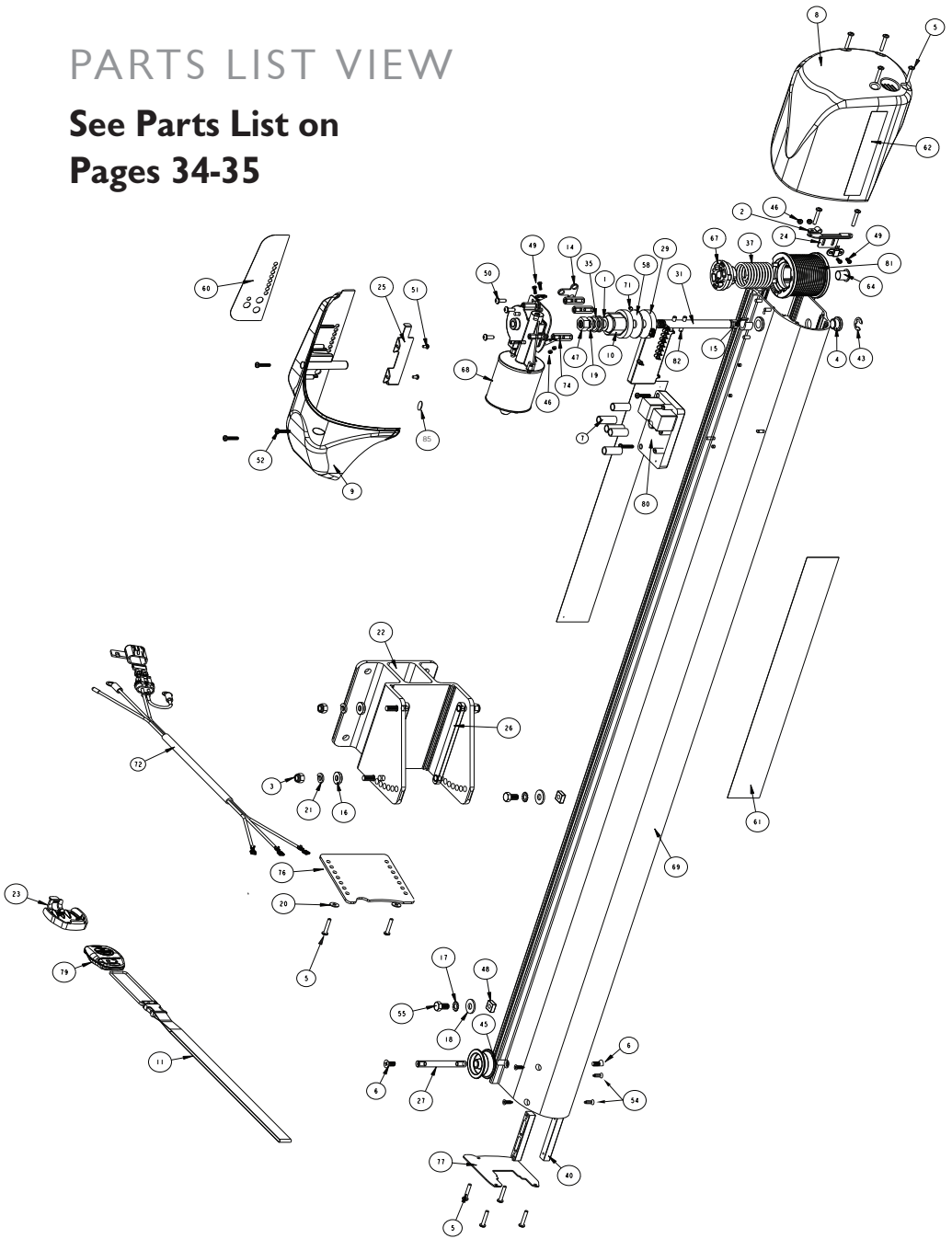

PARTS LIST VIEW

See Parts List on
Pages 34-35

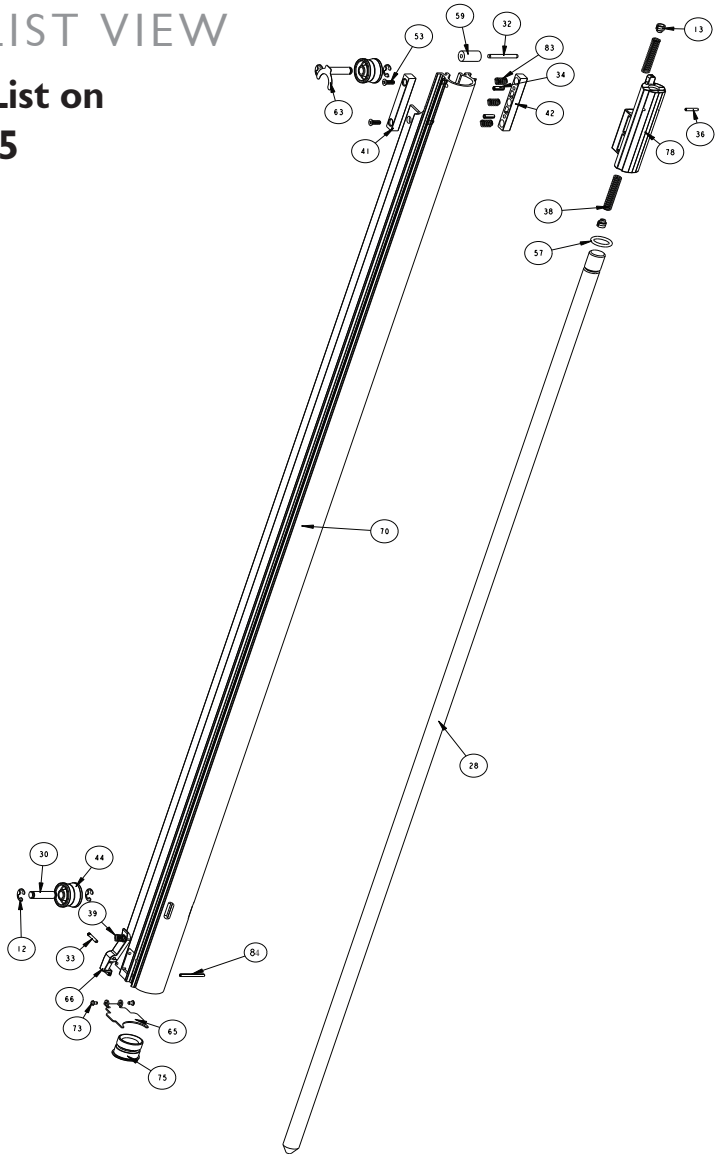

PARTS LIST VIEW

ITEM #	QTY	PART NUMBER	DESCRIPTION
1	1	990052	NYLATRON WASHER
2	1	2052510	CLAMP CABLE, 3/16"
3	4	2053101	NUT-PROP, NYLOCK (MED) 5/16" SS
4	2	2227304	BUSHING - HAT 1/2" SHAFT BRONZE
5	12	2263434	#8 - 18 x 1 SS PPH
6	2	2283410	SCREW, 1/4" - 20 X 3/4" FLAT
7	5	2305404	SHRINK TUBE .375 ID x 1.0"
8	1	2370270 / 2370271	COVER TALON, TOP, BLK / WHT
9	1	2370275 / 2370276	COVER TALON, BTM, BLK / WHT
10	1	2370813	COUPLER, DRIVE
11	1	2370818	LANYARD, REMOTE
12	4	2370832	C - CLIP, 3/8" LOW CLEARANCE - SS
13	2	2370850	CABLE - KEEPER
14	1	2371535	BUTTON SPACER
15	1	2371536	WRAP DRUM SPACER
16	4	2371746	WASHER .6875 X .3125, SS
17	2	2371747	LOCKWASHER 5/16" EXT.
18	2	2371749	5/16" FLAT WASHER, SS
19	1	2371753	1/2" FLAT WASHER, SS
20	2	2371754	#8 WASHER, 1/2" OD, SS
21	4	2371756	LOCK WASHER, 5/16" - SS
22	1	2371880	BRACKET, MOUNTING
23	1	2371883	REMOTE DASH HOLDER
24	1	2371887	BRACKET, HALL - SENSOR
25	1	2371918	BACKING PLATE, LED BOARD
26	2	2993803	STRAP-BRACKET/STUD ASSY
27	1	2372662	PIN - PULLEY, LONG
28	1	2372008 / 2372009	SPIKE, .75" x 8' / 6'
29	1	2372230	CLUTCH, BACK
30	2	2372316	SHAFT, IDLER
31	1	2372648	PIN, WRAP DRUM - DRIVE
32	1	2372652	PIN, 1/4" STOP
33	2	2372653	PIN, KNURLED - 1/8"
34	2	2372655	PIN, SPRING 3/16" x 5/8" SS
35	2	2372656	WASHER, BELLEVILLE - CLUTCH
36	1	2383464	SCREW-M4-0.70, SET SS
37	1	2372741	SPRING, TORSION - WRAP DRUM
38	2	2372742	SPRING, PISTON
39	1	2372743	SPRING, .36 x .5
40	2	2372820	SLIDE GIB, LOWER
41	1	2372821	SLIDE GIB, UPPER
42	1	2372822	SLIDE GIB, FLOATING
43	1	2373005	E-RING EXTERNAL SS .500
44	2	2373030	PULLEY, IDLER, SMALL
45	1	2373031	PULLEY, IDLER, LARGE
46	4	2373106	NUT - #4 - 40, NYLOCK, SS
47	1	2373107	NUT, CLUTCH
48	2	2373130	SQUARE NUT
49	4	2373439	SCREW #4 - 40 x 5/16" PPH, SS
50	6	2373481	SCREW #10 - 32 x 1/2" SEMS, PPH, SS
51	4	2373485	#6 - 32 x 1/4" TYPE F, PPH, SS
52	5	2373487	SCREW #8 - 32 x 5/8" PPMS, SS
53	2	2373489	SCREW #10 - 24 x 1/2" MACHINE
54	4	2373491	SCREW, #6 x .50 SS HI - LO
55	2	2373493	5/16 - 18 x 1/2 HHCS, SS
57	1	2374632	O-RING, 3/4" ID x .125

ITEM #	QTY	PART NUMBER	DESCRIPTION
58	1	2375116	CLUTCH, PAD
59	1	2375416	INSULATOR, 1/4" STOP PIN
60	1	2375560 / 61 / 62 / 63	DECAL, TALON CTRL PNL 6' WHT / 6' BLK / 8' WHT / 8' BLK
61	2	2375564	MINN KOTA DECAL LARGE
62	1	2375565 / 2375566	TALON DECAL WHITE / TALON DECAL BLACK
63	1	2375567	DECAL, CRANK UP ARROW
64	1	2376012	BEARING, WRAP DRUM
65	1	2376440	SHIELD - DEBRIS, SECOND STAGE
66	1	2377205	LATCH SECOND STAGE
67	1	2377905	HUB, WRAP DRUM
68	1	2377811	LIFT MOTOR FINAL ASSEMBLY
69	1	2378041 / 2378042	MACHINED OUTER EXTRUSION, 6' / 8'
70	1	2378016 / 2378017	EXTRUSION 2ND STAGE TALON, 6' / 8'
71	2	2378448	.187 X .125 MAGNET
72	1	2378510	POWER CORD, 14AWG, 3 CONDUCTOR
73	2	2378601	ALUM POP RIVET, 1/8"
74	3	2378800	SPACER, MOTOR MOUNT
75	1	2378825	ISOLATOR, SPIKE
76	1	2378806	WATER SHIELD - ALUM, DEFLECTOR TALON
77	1	2378807	WATER GUARD, BOTTOM
78	1	2991509	PISTON W/ MAGNETS ASM
79	1	2994044	REMOTE ASSEMBLY
80	1	2994046	CONTROL BOARD, MAIN
81	1	2997915	DRUM - MODULAR - ASM
82	2	3392640	PIN, DRIVESHAFT
83	3	2372740	SPRING, GIB TENSION
84	1	2372654	1/8" X 1 - 1/4" SS, SPRING PIN
85	1	3394605	O-RING, KNOB

INCLUDES ITEM #(S)	PART NUMBER	DESCRIPTION
69, 74, 50, 61, 4, 40, 54	2778011	EXTRUSION 1 ST STAGE SERV ASM 6'
69, 74, 50, 61, 4, 40, 54	2778012	EXTRUSION 1 ST STAGE SERV ASM 8'
42, 34	2772822	FLOATING SLIDE GIB w/PINS ASM
83	2882740	FLOATING GIB SPRING, INSTRC KT
41, 53	2882821	UPPER SLIDE GIB RPLCMNT KIT
70, 66, 39, 33	2778016	EXTRUSION 2 ND STAGE/LATCH ASM 6'
70, 66, 39, 33	2778017	EXTRUSION 2 ND STAGE/LATCH ASM 8'
66, 39, 33	2887205	LATCH ASM w/PIN & SPRING HDW
28, 84, 36, 57	2882008	SPIKE 8' REPLACEMENT KIT
28, 84, 36, 57	2882009	SPIKE 6' REPLACEMENT KIT
77, 5	2888807	WATER GUARD REPLACEMENT KIT
81, 37, 64, 67	2777910	WRAP DRUM REPLACEMENT KIT
24, 49, 46	2881887	BRACKET, HALL SENSOR RPLCMT KIT
68, 7	2887811	MOTOR ASM, HEAT SHRINK KIT
31, 82, 29, 71, 58, 10, 1, 19, 33, 35, 47, 4, 43, 82 (part # 2371755, 2378448 - not shown)	2772231	CLUTCH ASM, HARDWARE KIT
80, 7	2884045	SWA PCB ASM, HEAT SHRINK KIT
72, 7	2888510	POWER CHORD, HEAT SHRINK KIT
8, 62	2770271	COVER-TOP, TALON WHT w/ DECAL
8, 62	2770270	COVER-TOP, TALON BLK w/ DECAL
9, 60	2770275	COVER-BTTM, TALON BLK w/ DECAL 6'
9, 60	2770276	COVER-BTTM, TALON WHT w/ DECAL 6'
9, 60	2770277	COVER-BTTM, TALON BLK w/ DECAL 8'
9, 60	2770278	COVER-BTTM, TALON WHT w/ DECAL 8'
38, 13 (part # 2370840, 2370841 - not shown)	2770840	CABLE REPLACEMENT KIT 8'
38, 13 (part # 2370842, 2370841 - not shown)	2770842	CABLE REPLACEMENT KIT 6'

COMPLIANCE STATEMENTS



ENVIRONMENTAL COMPLIANCE STATEMENT:

It is the intention of Johnson Outdoors Inc. to be a responsible corporate citizen, operating in compliance with known and applicable environmental regulations and a good neighbor in the communities where we make or sell our products.

WEEE Directive:

EU Directive 2002/96/EC “Waste of Electrical and Electronic Equipment Directive (WEEE)” impacts most distributors, sellers and manufacturers of consumer electronics in the European Union. The WEEE Directive requires the producer of consumer electronics to take responsibility for the management of waste from their products to achieve environmentally responsible disposal during the product life cycle. WEEE compliance may not be required in your location for electrical and electronic equipment (EEE), nor may it be required for EEE designed and intended as fixed or temporary installation in transportation vehicles such as automobiles, aircraft and boats. In some European Union member states, these vehicles are considered outside of the scope of the Directive, and EEE for those applications can be considered excluded from the WEEE Directive requirement. This symbol (WEEE wheeled bin) on product indicates the product must not be disposed of with other household refuse. It must be disposed of and collected for recycling and recovery of waste EEE. Johnson Outdoors Inc. will mark all EEE products in accordance with the WEEE Directive. It is our goal to comply in the collection, treatment, recovery and environmentally sound disposal of those products; however, these requirements do vary within European Union member states. For more information about where you should dispose of your waste equipment for recycling and recovery and/or your European Union member state requirements, please contact your dealer or distributor from which your product was purchased.

FCC COMPLIANCE

This device complies with Part 15 of the FCC rules.

Operation is subject to the following two conditions:

1. This device may not cause harmful interference.
2. This device must accept any interference that may be received, including interference that may cause undesired operation.

Changes or modifications not expressly approved by Johnson Outdoors Marine Electronics, Inc. could void the user's authority to operate this equipment.

This product meets the applicable Industry Canada technical specifications / Le présent matériel est conforme aux spécifications techniques applicables d'Industrie Canada.

NOTE: This equipment has been tested and found to comply with the limits for a Class B digital device, pursuant to part 15 of the FCC Rules. These limits are designed to provide reasonable protection against harmful interference in a residential installation. This equipment generates, uses and can radiate radio frequency energy and, if not installed and used in accordance with the instructions, may cause harmful interference to radio communications. However, there is no guarantee that interference will not occur in a particular installation. If this equipment does cause harmful interference to radio or television reception, which can be determined by turning the equipment off and on, the user is encouraged to try to correct the interference by one or more of the following measures:

- Reorient or relocate the receiving antenna.
- Increase the separation between the equipment and receiver.
- Connect the equipment into an outlet on a circuit different from that to which the receiver is connected.
- Consult the dealer or an experienced radio/TV technician for help.

Transmitter Model: 2994044

- IC: 4397A-T62TALON
- FCC ID: T62TALON
- Carrier Frequency: 433.92MHz
- RF output power: 87.07 dBuV/m measured at 3m yield EIRP of -8 dBm (.15 milliWatts)

Receiver Model: 2994046

- IC: 4397A-T62TALRCVR

LIMITED WARRANTY ON MINN KOTA TALON SHALLOW WATER ANCHORS:

Johnson Outdoors Marine Electronics, Inc. ("JOME") extends the following limited warranty to the original purchaser only. Warranty coverage is not transferable.

MINN KOTA FIVE-YEAR LIMITED WARRANTY ON MECHANICAL PARTS (excluding: control board, motor, remote)

JOME warrants to the original purchaser only that the purchaser's new Minn Kota Talon shallow water anchor's mechanical parts will be materially free from defects in materials and workmanship appearing within five (5) years after the date of purchase. JOME will (at its option) either repair or replace, free of charge, any mechanical parts found by JOME to be defective during the term of this warranty. Such repair or replacement shall be the sole and exclusive liability of JOME and the sole and exclusive remedy of the purchaser for breach of this warranty.

MINN KOTA TWO-YEAR LIMITED WARRANTY ON ELECTRICAL PARTS (includes: control board, motor, remote)

JOME warrants to the original purchaser only that the purchaser's new Minn Kota Talon shallow water anchor's electrical parts will be materially free from defects in materials and workmanship appearing within two (2) years after the date of purchase. JOME will (at its option) either repair or replace, free of charge, any electrical parts found by JOME to be defective during the term of this warranty. Such repair or replacement shall be the sole and exclusive liability of JOME and the sole and exclusive remedy of the purchaser for breach of this warranty.

MINN KOTA LIFETIME LIMITED WARRANTY ON THE SPIKE

JOME warrants to the original purchaser only that the spike of the purchaser's new Minn Kota Talon shallow water anchor will be materially free from defects in materials and workmanship appearing within original purchaser's lifetime. JOME will (at its option) either repair or replace, free of charge, any mechanical parts found by JOME to be defective during the term of this warranty. Providing a new spike shall be the sole and exclusive liability of JOME and the sole and exclusive remedy of the purchaser for breach of this warranty; **and the purchaser shall be responsible for installing, or for the cost of labor to install, any new spike provided by JOME.**

EXCLUSIONS AND LIMITATIONS

This limited warranty does not apply to product used commercially or for rental purposes. This limited warranty does not cover normal wear and tear, blemishes that do not affect the operation of the product, or damage caused by accidents, abuse, alteration, modification, shipping damages, acts of GOD, negligence of the user or misuse, improper care or insufficient maintenance.

DAMAGE CAUSED BY THE USE OF OTHER REPLACEMENT PARTS NOT MEETING THE DESIGN SPECIFICATIONS OF THE ORIGINAL PARTS WILL NOT BE COVERED BY THIS LIMITED WARRANTY. The costs of normal maintenance or replacement parts which are not in

breach of the limited warranty are the responsibility of the purchaser. Prior to using products, the purchaser shall determine the suitability of the products for the intended use and assumes all related risk and liability. Any assistance JOME provides to or procures outside the terms, limitations or exclusions of this warranty will not constitute a waiver of the terms, limitations or exclusions, nor will such assistance extend or revive the warranty. JOME will not reimburse for any expenses incurred by the purchaser in repairing, correcting or replacing any defective products or parts, except those incurred with JOME's prior written permission.

HOW TO OBTAIN WARRANTY SERVICE

To obtain warranty service in the U.S., the product believed to be defective, and proof of original purchase (including the date of purchase) must be presented to a Minn Kota Authorized Service Center or to Minn Kota's factory service center in Mankato, MN. Any charges incurred for service calls, transportation or shipping/freight to/from the Minn Kota Authorized Service Center or factory, labor to haul out, remove, re-install or re-rig products removed for warranty service, or any other similar items are the sole and exclusive responsibility of the purchaser. Products purchased outside of the U.S. must be returned prepaid with proof of purchase (including the date of purchase and serial number) to any Authorized Minn Kota Service Center in the country of purchase. Warranty service can be arranged by contacting a Minn Kota Authorized Service Center or by contacting the factory at 1-800-227-6433 or email service@minnkotamotors.com.

Products repaired or replaced will be warranted for the remainder of the original warranty period [or for 90 days from the date of repair or replacement, whichever is longer]. For any product that is returned for warranty service that JOME finds to be not covered by or not in breach of this limited warranty, there will be a billing for services rendered at the prevailing posted labor rate and for a minimum of at least one hour.

Note: Do not return your Talon to your retailer. Your retailer is not authorized to repair or replace them.

THERE ARE NO EXPRESS WARRANTIES OTHER THAN THESE LIMITED WARRANTIES. IN NO EVENT SHALL ANY IMPLIED WARRANTIES, INCLUDING ANY IMPLIED WARRANTIES OF MERCHANTABILITY OR FITNESS FOR PARTICULAR PURPOSE, EXTEND BEYOND TWO YEARS FROM THE DATE OF PURCHASE. IN NO EVENT SHALL JOHNSON OUTDOORS MARINE ELECTRONICS L.L.C. BE LIABLE FOR INCIDENTAL, CONSEQUENTIAL OR SPECIAL DAMAGES. Without limiting the foregoing, JOME assumes no responsibility for loss of use of product, loss of time, inconvenience or other damage.

HOW DOES STATE LAW APPLY? Some states do not allow limitations on how long an implied warranty lasts or the exclusion or limitation of incidental or consequential damages, so the above limitations and/or exclusions may not apply to you. This warranty gives you specific legal rights, and you may also have other legal rights which vary from state to state.

It is the express wish of the parties involved that this document and any related documents be drafted in English.





minnkotamotors.com

**MINN KOTA CONSUMER
& TECHNICAL SERVICE**

P.O. Box 8129
Mankato, MN 56002

121 Power Drive
Mankato, MN 56001
Phone (800) 227-6433
Fax (800) 527-4464

