

PROCEDURES TO TAKE DURING AN ALARM

⚠ WARNING: THE ACTUATION OF THE FUME ALARM INDICATES THE PRESENCE OF DANGEROUS LEVELS OF GASOLINE OR PROPANE VAPORS THAT COULD CAUSE AN EXPLOSION OR FIRE IF NO ACTION IS TAKEN:

- 1) Turn off all electrical equipment, generator, extinguish all open flames (oven, cook top, smoking materials, etc.).
- 2) Turn off the engine (s) if safe navigation conditions exist.
- 3) Open the engine compartment, ports, hatches and doors and ventilate the area.
- 4) If you are ashore evacuate the boat. Do not return until the area is ventilated and the detector has returned to normal standby condition.
- 5) Proceed with caution and locate and repair the cause of the leak. Seek a qualified technician if necessary.
- 6) Do not start or use the boat until the necessary repairs were made.

TROUBLE SHOOTING GUIDE

Problem	Cause
No Power	Wire connection, missing or blown fuse, reversed wires, defective unit
Locked In Wait	Replace sensor assembly SA-186-SB
Immediate Alarm When Turned On	Cable disconnected or broken, Sensor assembly, check sensor assembly red light
No Audible Alarm	Return for repair or replacement
No Alarm During Supervision Tests	Return for repair or replacement
Red LED On Sensor Assembly Is Off	Unit is off, Cable disconnected or broken, SA-186-SB defective
No Alarm When Sensor is Removed	If panel tests OK replace SA-186-SB
No Alarm With Lighter Test	If the panel tests OK replace sensor SA-186-S, if that does not remedy the condition replace the sensor assembly SA-186-SB

SPECIFICATIONS

Power Supply - 12 VDC Operational Voltage - 7 to 15 VDC Power Draw - .200 amps @ 14 VDC
 Operating Temp -22⁰ F - 160⁰ F Fume Alarm Threshold - <20% LEL of Gasoline and Propane
 Other Gases Detected But Not Listed; Alcohol, Acetone, Hydrogen and most other flammable gases.
 Heat Sensor – Rate of Rise auto reset 194⁰ F

LIMITED PRODUCTS WARRANTY

MTI INDUSTRIES, INC. Warrants to the original purchaser that this detector will be free from defects of material or workmanship for a period of One (1) year. If proven to have been defective in original materials or workmanship and returned, delivery costs prepaid, MTI INDUSTRIES, INC. will repair or replace this product free of charge.

LIMITS OF WARRANTY

Repair or replacement is your exclusive remedy under this limited warranty or any other warranty (including any implied warranty of merchantability for a particular purpose). Any and all implied warranties or merchantability or fitness for a particular purpose shall be limited to the warranty period from the original date of purchase. MTI INDUSTRIES, INC., its dealers and distributors shall in no case be responsible or in any way liable for any incidental or consequential damages for any reason. Some states do not allow the limitation or exclusion of incidental or consequential damages, or allow limitations on how long an implied warranty lasts, so the above limitations may not apply to you. This warranty gives you specific rights, and you may also have other rights that may vary from state to state.

WARRANTY RETURN POLICY

Warning- opening the product for any reason voids the warranty. There are no user serviceable parts in the case. No product will be accepted for repair or replacement without an authorization number (RA). RA numbers may only be issued by MTI or authorized distributors. Include an explanation of the problem, the original dated sales receipt, and your return address. Send, shipping prepaid, to: MTI Industries, Inc. 31632 N. Ellis Dr. #301, Volo, IL. 60073. E-mail info@mtiindustries.com www.mtiindustries.com

MARINE TECHNOLOGIES, INC.

SAFE-T-ALERT™ SA-10XL MARINE GASOLINE/PROPANE, BILGE WATER AND FIRE DETECTOR USER'S MANUAL

IMPORTANT

PLEASE READ CAREFULLY AND SAVE

This manual contains important information. Purchasers who install this detector for use by others must leave this manual with the user.

ALL RIGHTS RESERVED

MTI FORM NO: SA10-297-2

**⚠ WARNING
LIMITATIONS OF
FUME DETECTORS**

Gasoline Fume detectors will not work without power. Examples causing no detector power are: an open circuit breaker, blown or missing fuse, broken wire or improper wire crimp connection.

CAUTION - This detector will only indicate the presence of gasoline fumes at the sensor. The sensor cannot monitor a compartment that is separated by a bulkhead. Gasoline fumes may be present in other areas. MTI recommends that sensors be installed in compartments containing fuel tanks and or engine(s) and compartments where gasoline or propane fumes may accumulate.

Gasoline fume detectors may not be heard. The alarm loudness is designed to meet or exceed regulatory standards, however, the alarm may not be heard if detectors are located in remote locations. The alarm may not be heard by persons who are hard of hearing.

⚠ WARNING

WHY EVERY BOAT NEEDS A FUME DETECTOR

Fumes from a half a cup of gasoline have the explosive force of six sticks of dynamite. Gasoline vapors can develop in fuel pumps, fuel tanks, fuel lines, carburetors and fuel systems. The SAFE-T-ALERT™ SA-10XL is an early warning monitor. It is designed to notify you when 20% or less of the lower explosive limit of gasoline or propane vapors are present in the monitored area. It can also warn you of rising bilge water levels and excessive heat in the monitored area.

Power Supply 12 vDC

Recommended Wire Gauge 18 Ga.

**Wire Color Code Red (+) Black (-) Fuse In-Line 1 amp to the Red lead of the panel
Yellow To either lead of the water sensor**

White

.....To one White wire on the heat sensor

Blue

One to the unused lead of the water sensor,

Blue To the black wire on the heat sensor

WHERE TO INSTALL THE PANEL AND SENSORS

- Locate the control panel in the helm area where it can easily be seen and heard.
- Locate the fume sensor on a forward bulkhead wall about starter height.
- Locate the heat sensor as high as possible in the engine room.
- Locate the water sensor about 4" above the existing bilge pump switch.

WHERE NOT TO INSTALL THE PANEL AND SENSOR

- DO NOT mount the control panel under a cowling, or glass or plastic panel where it may not be seen or heard.
- DO NOT locate the fume sensor above batteries. Hydrogen from the batteries may cause false alarms.
- DO NOT locate the fume sensor behind any obstruction that will prevent air flow to the sensor.
- DO NOT locate the fume sensor on the aft bulkhead. Water on the sensor will cause permanent damage to the sensor and sensor assembly.
- DO NOT locate the sensor within 12 inches of exhaust lines. High heat may cause false alarms.

INSTALLATION INSTRUCTIONS

CAUTION: Gasoline and Propane are heavier than air. Mount the Sensor at the engine starter height. Starter height is dependent on the engine installation.

1. After referring to the "Where To Install the Panel and Sensor" and Where NOT To Install the Panel and Sensor" select an area at the helm with at least 3" of clearance for the housing. Drill a 2 1/8" mounting hole and install the housing using the hardware supplied. DO NOT CONNECT POWER UNTIL THE INSTALLATION IS COMPLETE.
2. Connect one end of the 20 foot cable assembly to the control panel and run the cable to the engine compartment location of the sensor assembly.
3. Mount the sensor assembly about starter height on the forward bulkhead wall with the cable down toward the bilge. **Do not mount the sensor where it can get wet or emerged in water. Do not mount with the cable up as water can run into the sensor assembly and damage the sensor assembly.** Connect the 20 foot cable.
4. Mount the float switch with the float down, about 4" above the automatic bilge pump switch. Connect one Blue lead to a float lead and the Yellow lead to the other float lead.
5. Connect the Blue and White Leads to the Heat Sensor, one lead to each terminal. Install the sensor above the engine(s).
6. Use a 1 amp in-line fuse and connect the RED power lead to the 12 vDC battery positive (+). Connect the BLACK lead to the battery ground (-).

Control Panel

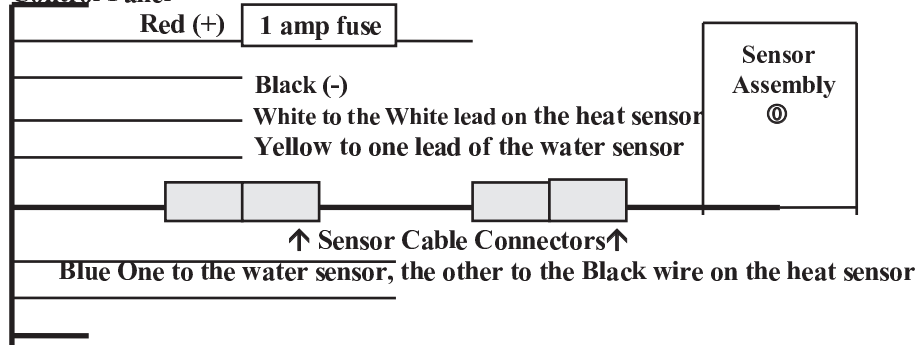

OPERATION

The SA-10XL has supervisory circuits to warn of a missing sensor, sensor assembly malfunction, disconnected or a broken connector sensor cable.

1. Press the ON pad on the control panel. The Yellow Wait light should turn lit. Press the Test pad to check the operation of the alarm sounder and alarm light. In about two minutes the Yellow Wait light will turn off and the Green Operational light will light. The detector is now operational and monitoring for gas fumes.
2. When the sensor detects gasoline or propane fumes above the alarm threshold levels, the alarm will sound and the RED Alarm light will turn on. The alarm will continue until the air in the monitored area returns to safe levels. **SEE PROCEDURES TO TAKE DURING AN ALARM.**

TESTING



WARNING

TEST THIS DETECTOR'S OPERATION AFTER THE BOAT HAS BEEN IN STORAGE, BEFORE EACH TRIP AND AT LEAST ONCE PER WEEK DURING USE.

1. With the unit on, check the sensor assembly light. The RED light should be lit.
2. When the Green normal operation light is lit the sensor assembly can be tested.



WARNING

NEVER ENTER THE ENGINE COMPARTMENT WITH AN OPEN FLAME OR LIT SMOKING MATERIALS. OPEN FLAMES AND SMOKING MATERIALS CAN CAUSE AN EXPLOSION AND OR FIRE.

USE ONLY A BUTANE LIGHTER TO PERFORM THIS TEST, NEVER USE GAS SOAKED MATERIAL.

3. **SENSOR TEST:** Direct the lighter towards the sensor and depress the lever to release gas into the sensor. The alarm should sound and the RED alarm light on the control panel should be lit.
4. **SUPERVISORY TEST 1:** Disconnect one end of the 20 foot connector cable. The alarm should sound and the RED alarm light on the control panel should be lit.
5. **SUPERVISORY TEST 2:** Use a pull and rocking motion to remove the sensor (Figaro 813) from the sensor assembly. The alarm should sound and the RED alarm light on the control panel should be lit.
6. **WATER SENSOR:** Raise the float and the alarm Red Water light should activate.
7. **HEAT SENSOR: (Caution- Never use an open flame)** Hold a 100 watt light bulb on the tip of the sensor. The alarm and light should activate in about 30 seconds.

IF THE UNIT DID NOT TEST PROPERLY REFER TO THE TROUBLE SHOOTING GUIDE

MAINTENANCE

1. Keep the sensor free of dust and debris. It is recommended that the sensor (MTI Part No. SA-186-S) be replaced annually due to the contamination caused in the marine environment.
2. Remove the sensor whenever the bilge compartment or engine compartment equipment is being cleaned, painted, power washed, etc. Direct contact with chemicals, WD-40, water, oil, etc. can cause permanent damage to the sensor.