



EAGLE *PRO*

6-ROTOR DRONE WITH WIFI CAMERA

User's Guide for Model DRW676 v1523-01

Warnings & Precautions

Important Safety Instructions

- Read these instructions.
- Keep these instructions for future reference.
- Heed all Warnings.
- Follow all instructions.
- Intended for children ages 14 and higher.
- Adult supervision is required.
- Only use attachments/accessories specified by the manufacturer.
- Before flying, always check the hexacopter body, rotors, and battery for any damage or obstructions.
- Battery should be free from cracks or swelling.
- Always keep the rotors clear of any obstructions to avoid potential damage and injury.
- Manufacturer and dealer assume no liability for accidental damages from improper use or installation of parts, or from damage incurred from worn or broken parts.
- Pilots are responsible for their actions and any damage caused from improper use.
- Pilots should keep the hexacopter in sight at all times during flights. If you lose sight of the hexacopter at any time, power down and cease flight immediately.
- Only fly in large, open areas that are free from obstacles or potential hazards, such as trees, power lines, ceiling fans, and the like.
- Never fly over open bodies of water.
- Never fly the hexacopter at night.
- Never try to retrieve the hexacopter from areas you cannot safely reach, such as rooftops or trees.
- Always launch the hexacopter from a flat, level surface.
- Never launch the hexacopter from your hand.
- Never leave the hexacopter unattended while it is powered on.

FCC Warnings

Warning: Changes or modifications to this unit not expressly approved by the party responsible for compliance could void the user's authority to operate the equipment.

NOTE: This equipment has been tested and found to comply with the limits for a Class B digital device, pursuant to Part 15 of the FCC Rules. These limits are designed to provide reasonable protection against harmful interference in a residential installation. This equipment generates, uses, and can radiate radio frequency energy and, if not installed and used in accordance with the instructions, may cause harmful interference to radio communications. However, there is no guarantee that interference will not occur in a particular installation. If this equipment does cause harmful interference to radio or television reception, which can be determined by turning the equipment off and on, the user is encouraged to try to correct the interference by one or more of the following measures:

- Reorient or relocate the receiving antenna.
- Increase the separation between the equipment and receiver.
- Connect the equipment into an outlet on a circuit different from that to which the receiver is connected.
- Consult the dealer or an experienced radio/TV technician for help.

Additional Warnings & Precautions

- **WARNING:** To reduce the risk of fire or electric shock, do not expose this apparatus to rain, moisture, dripping, or splashing.

AVIS: Pour réduire le risque d'incendie ou de choc électrique, ne pas exposer cet appareil sous la pluie et l'humidité.

- **CAUTION:** Use of controls or adjustments or performance of procedures other than those specified may result in hazardous radiation exposure.
- **WARNING:** Changes or modifications to this unit not expressly approved by the party responsible for compliance could void the user's authority to operate the equipment.
- **CAUTION:** Danger of explosion if battery is incorrectly replaced. Replace only with the same or equivalent type.
AVIS: Danger d'explosion si les piles sont remplacées de façon incorrect. Remplacer les piles seulement par le même type de pile ou l'équivalent.
- Lithium batteries, like all rechargeable batteries, are recyclable and should be recycled or disposed of according to state and local guidelines. They should never be disposed of in normal household waste, and they should never be incinerated, as they might explode. Contact your local government for disposal or recycling practices in your area.
- **WARNING:** Shock hazard - Do Not Open.
AVIS: Risque de choc électrique - ne pas ouvrir
- Battery shall not be exposed to excessive heat such as sunshine, fire, or the like.
Les piles ne doivent pas être exposées à de forte chaleur, tel qu'à la lumière du soleil, au feu ou autres choses de semblable.
- Keep new and used batteries away from children. If the battery compartment does not close securely, stop using the product and

keep it away from children.

Gardez les piles neuves et d'occasion à partir des enfants. Si le compartiment de la batterie ne pas fermer correctement, cesser d'utiliser le produit et garder loin des enfants.

- If you think batteries might have been swallowed or placed inside any part of the body, seek immediate medical attention.
Si vous pensez que les batteries peuvent avoir été avalé ou placé à l'intérieur d'une partie du corps, consulter immédiatement un médecin.
 - Do not mix old and new batteries.
Ne pas mélanger vieilles et nouvelles batteries.
 - Completely replace all old batteries with new ones.
Remplacer complètement toutes les piles par des neuves.
 - Do not mix alkaline, standard (carbon-zinc), or rechargeable (ni-cad, ni-mh, etc) batteries.
Ne mélangez pas des piles alcalines, standard (carbone-zinc) ou rechargeables (Ni-Cd, Ni-MH, etc) batteries.
 - Batteries should be recycled or disposed of as per state and local guidelines.
Piles doivent être recyclées ou éliminées selon les directives étatiques et locales.
 - **WARNING:** This product may contain chemicals known to the State of California to cause birth defects, or other reproductive harm (California Prop 65). Wash hands after handling.
 - This product meets and complies with all Federal regulations.
-

Table of Contents

Orientation		5
Includes	Remote Control	
Overview		
Batteries & Charging		7
Battery Info	Battery Charging Procedure	
Remote Control Battery Installation		
Pre-Flight Calibration		10
Hexacopter/Remote Link		
Trim Adjustment		12
Setting Trim & Countering Drift		
Flying Tips & Features		14
Tips for Safe Operation	Headless Mode	
Speed Setting	Flips & Tricks	
Auto-Return		
WiFi Mode		16
Sky Rider Drones App	Flight Screen	
WiFi Flight	Intuitive Mode	
Start Screen	Attaching the Smartphone Cradle	
Factory Reset		20
Reset Procedure		
Troubleshooting		22
Repair		23
Rotor Replacement		
Parts		24
Parts Replacement	Parts List	
Parts Diagram		
Company Information		26
Contact Information	Warranty	
International Support		

Orientation

Includes

- Remote control: requires 4 AA batteries (not included)
- 2 rechargeable lithium polymer batteries
- USB cable for battery recharge
- 6 replacement rotors
- Screwdriver
- Detachable smartphone cradle

Overview

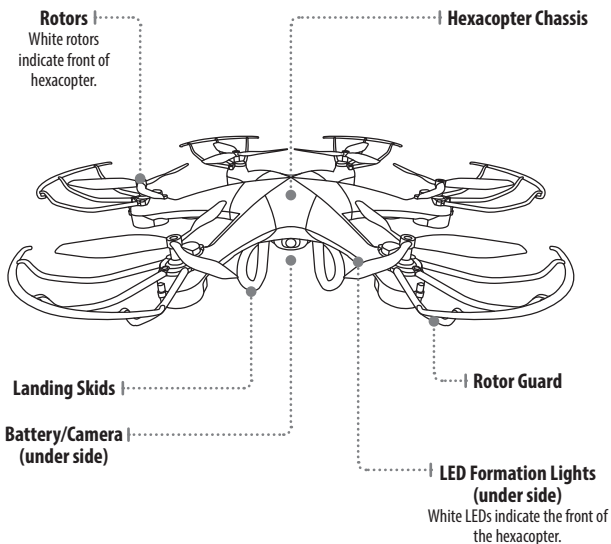

Orientation

Remote Control

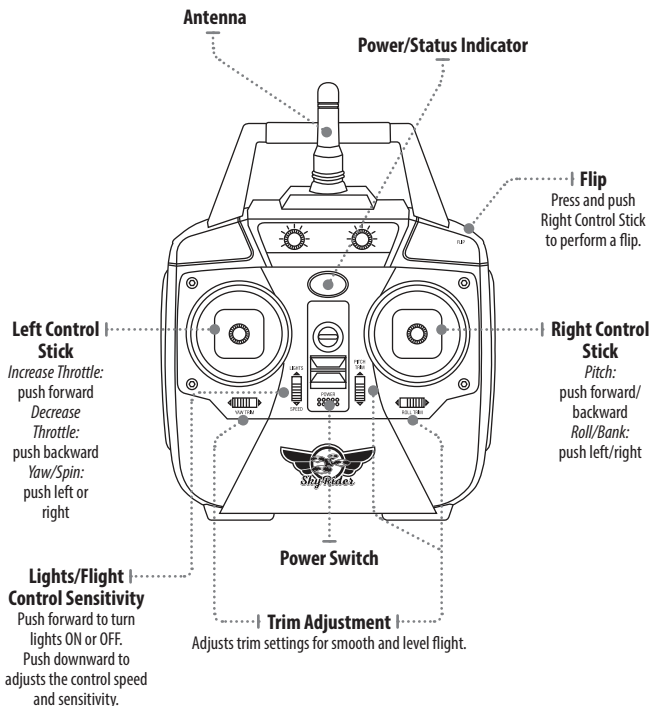

Batteries & Charging

Battery Info

BATTERY TYPE	SPECIFICATION	DURATION	CHARGE TIME
Hexacopter Li-Po Battery	3.7V/750mAH	6 to 8 minutes flight time	Approx. 120 minutes
Remote AA Batteries	1.5V	Approx. 18 hours	Non-rechargeable

Remote Control Battery Installation

Use included screwdriver

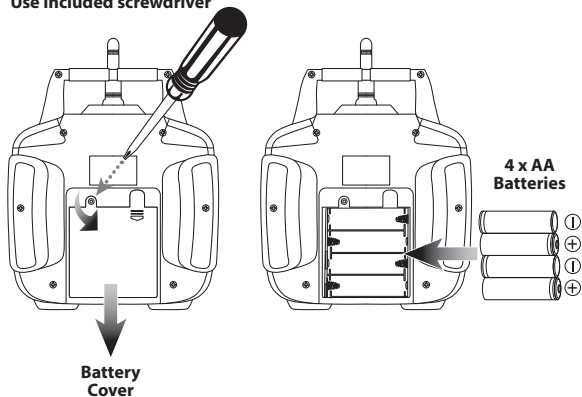

Batteries & Charging

Battery Charging Procedure

The hexacopter's lithium-polymer battery must be charged before the unit can be flown. Before charging, be sure the hexacopter and remote control are powered off. Failure to do so may result in injury.

Step 1

Make sure the hexacopter is powered OFF, then open the battery cover by gently pulling towards the rear of the craft.

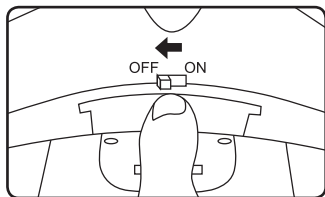

Step 2

Disconnect the battery and hexacopter power plugs. Slide the battery out of its bay for easier access or replacement.

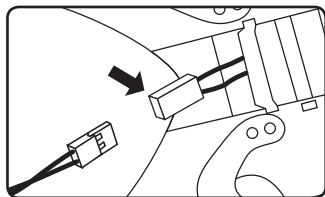

Step 3

Attach the plug on the battery to the corresponding plug on the USB charging cable (included).

Be sure to match the plugs correctly or damage may occur.

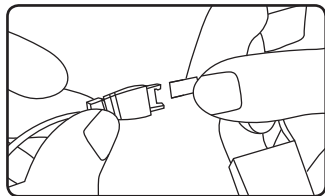

Step 4

Connect the USB charging cable to the USB port of a powered ON computer.

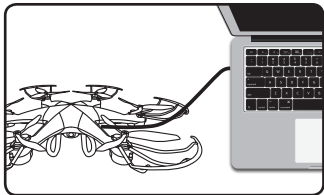

While charging, the red light in the USB charging cable will be ON.

When charging is complete, the red light in the USB charging cable will be OFF.

LIGHT	STATUS
Red Light ON	Charging
Red Light OFF	Ready

Step 5

When charging is complete, reconnect the power plugs, and close the battery cover.

Be sure to match the plugs correctly or damage may occur.

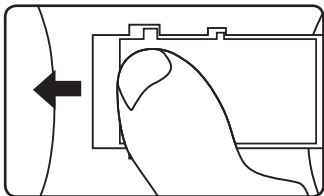

Pre-Flight Calibration

Hexacopter/Remote Link

Before flying, the hexacopter and the remote must be linked together, and the gyroscopes on the hexacopter must be allowed to calibrate to ensure smooth and level flight.

Begin with the hexacopter and remote powered off.

Step 1

Place the hexacopter on a flat, level surface before you begin.

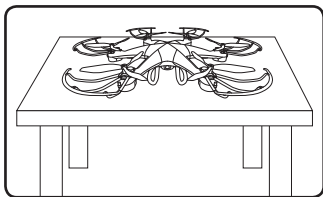

Step 2

Power the remote control ON. The light on the remote will blink as it searches for the signal from the hexacopter.

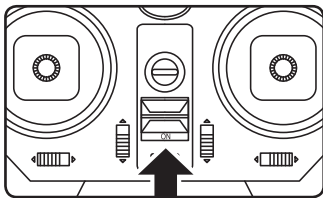

Step 3

Power the hexacopter ON. The LED formation lights will blink in unison as the hexacopter searches for a signal from the remote. An audible chime will sound when the remote and the hexacopter have linked with each other.

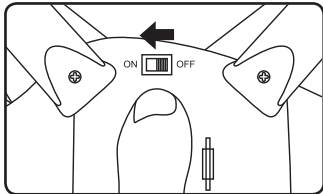

Step 4

Push the Left Control Stick directly forward, wait for a chime to sound, then pull the stick directly backward, and wait for a second chime.

When this last chime has sounded, the hexacopter is calibrated and ready to fly.

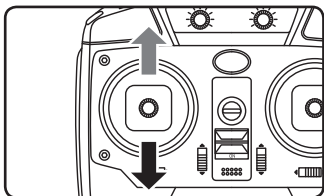

Step 5

Attempt a stable hover, low to the ground or surface you started on. If you notice a tendency to drift, you may need to adjust the trim controls to fine tune the handling (see next section).

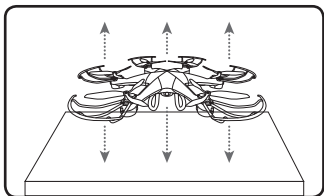

Trim Adjustment

Setting Trim & Countering Drift

Even after the hexacopter is calibrated, it may show a tendency to drift while airborne. Adjusting the trim will help counter this effect and allow you to better control the craft. To avoid potential damage, adjust the trim while in a stable hover, and do not make any sudden movements with the flight controls. Adjust one trim setting at a time to avoid confusion.

Remember, the white propeller blades/LEDs indicate the front of the hexacopter.

Note that, while adjusting the trim will help with drift, it will not eliminate it entirely. Turbulence and other environmental factors may still act on the hexacopter to influence its direction and flight.

DRIFT TYPE

Hexacopter yaws/spins in place.

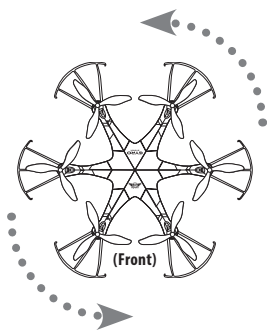

SOLUTION

Use Yaw Trim buttons under the Left Control Stick.

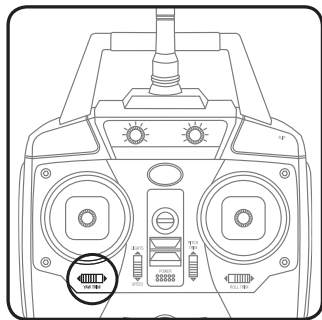

Hexacopter pitches/angles forward or backward.

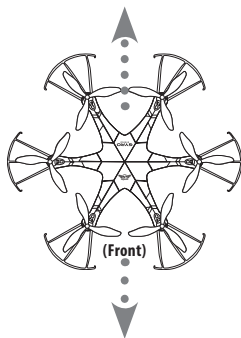

Use Pitch Trim buttons left of the Right Control Stick.

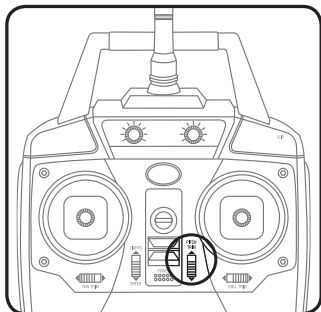

Hexacopter rolls/banks left or right.

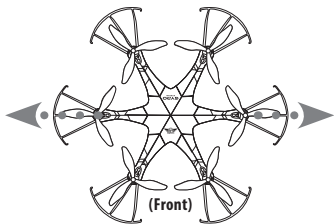

Use Roll Trim buttons under the Right Control Stick.

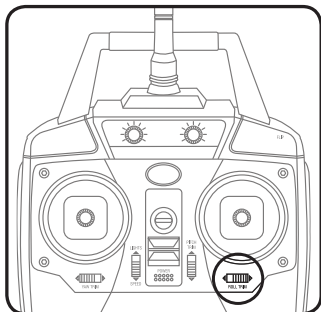

Flying Tips & Features

Tips for Safe Operation

- Only fly in large, open spaces, such as a field or a very large indoor area, free of obstacles like power lines, trees, ceiling fans, etc.
- When flying indoors, avoid walls and ceilings, as the hexacopter will be drawn towards them if closer than 2 to 3 feet.
- Stand behind the hexacopter when first taking off, so that you and the hexacopter are facing the same “forward” direction. This will make it easier to know which direction the unit is flying. Also, remember that the white propellers and LED lights indicate the front of the hexacopter.
- Practice basic flight operations like take off, hovering, and landing.
- Flying inside, at low speed and low to the ground will reduce the chance of turbulence that can negatively affect the stable flight of the hexacopter.
- Novice pilots should move the controls slowly and deliberately, using one control at a time, to get used to the hexacopter’s flying characteristics. Next try combining the pitch and roll controls (forward/backward and left/right on the Right Control Stick) to fly the hexacopter similar to the way an airplane flies. After mastering this, try the yaw controls (left/right on the left thumbstick) to spin the hexacopter in place and perform more complex maneuvers.
- When you crash, throttle down the engines IMMEDIATELY to reduce the chance of permanent damage to the hexacopter and other objects.
- If anything obstructs the propellers for any reason, throttle down IMMEDIATELY and safely clear the obstruction. Check for possible damage before flying again.

Speed Setting

The hexacopter has three settings for the responsiveness of the flight controls: 30%, 60%, and 100%. The higher settings allow for faster and more precise control of the craft. It is recommended to start with the lowest setting, then as you become more skilled at flying, increase the sensitivity as you see fit.

- **30%:** Intended for novice pilots. Gives smooth and predictable control.
- **60%:** Intended for intermediate pilots. The hexacopter will move and respond faster to all control inputs.
- **100%:** Intended for expert pilots. Highest setting for maximum performance.

Auto-Return

This feature will put the craft into an autonomous flight mode that immediately returns the hexacopter to a set point of origin. To set the point of origin, press down (into the body of the remote control) on the **Right Control Stick**. The remote will emit a chime. If you press the Right Control Stick again, the hexacopter will enter Auto-Return and fly back to the point of origin. Throttle control will still function, but other controls are locked out until the craft reaches its destination, or Auto-Return is disabled. Press the Right Control Stick at any time to disable Auto-Return.

Headless Mode

Headless Mode disables the default orientation of the hexacopter, where the white rotors/LEDs indicate the front of the craft. Instead, the craft will reorient its "front" based on the first **Right Control Stick** input from the user. This can be useful if you become disoriented while flying, or cannot visually determine which direction is "true front".

To activate Headless Mode, press down (into the body of the remote control) on the **Left Control Stick**. Press again to deactivate Headless Mode.

Flips & Tricks

Before attempting any stunts, be sure that there is ample clear space around the hexacopter, ideally 9 to 10 ft. in every direction. It is not recommended to attempt to stunt around or through any obstacles, as this may result in unintended damage.

To perform a flip, follow the diagram below.

Press and hold the Flip button, then move the Right Control Stick in any direction.

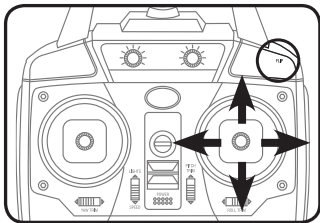

Hexacopter will perform flip in the desired direction.

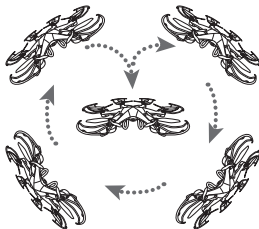

WiFi Mode

Sky Rider Drones App

The hexacopter features a WiFi flight mode that lets you fly using a smartphone and the craft's on board camera. Scan the appropriate QR code below to download and install the free app software. The app can also be found on the Apple App Store or Google Play Store by searching for **Sky Rider Drones**.



IOS/iPhone (Apple)



Google Play
(Android)



360 (Android)

WiFi Flight

Note that WiFi control may be disabled if the flying area is experiencing interference from nearby 2.4G equipment. It is recommended to move to another area and try again.

Step 1

Place the hexacopter on a flat, level surface before you begin.

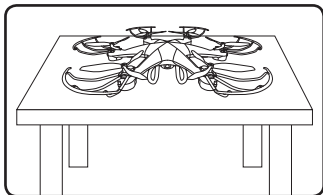

Step 2

Power the hexacopter ON. The LED formation lights will blink in unison as it awaits a signal from your smartphone.

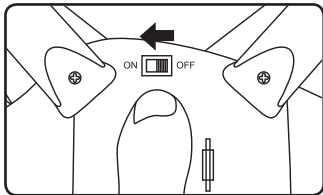

Step 3

Open your phone's WiFi settings and activate WiFi, then search for and select **Sky Rider** from the WiFi networks menu.

Once connected, open the app and click on the **Play or Start icons** to begin flying.

When WiFi mode is active, you can save video and images directly to your smartphone.

Start Screen

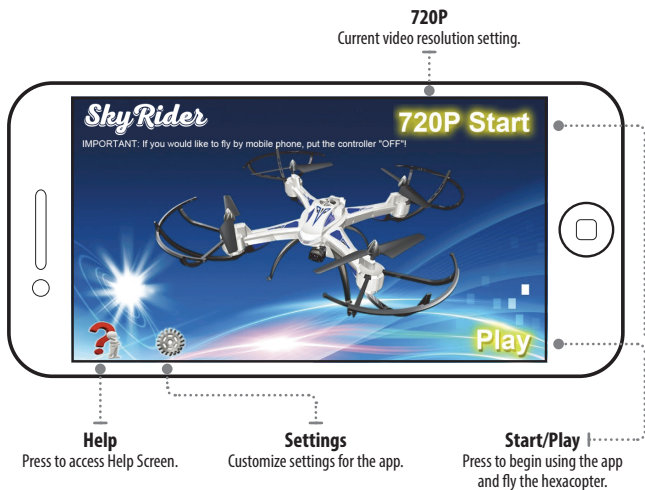

WiFi Mode

Flight Screen

Note that the airplane and runway graphic (pictured below) is replaced by the view from the hexacopter's on board camera when using the app.

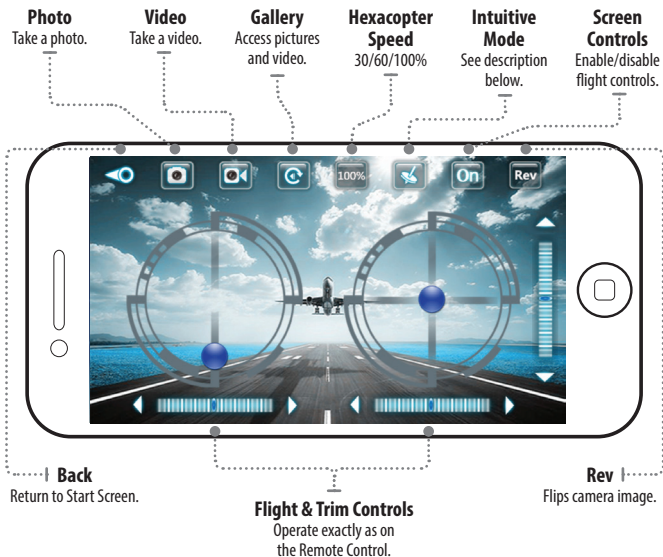

Intuitive Mode

This mode uses the G-Sensor in a connected smartphone for directional control during flight. Tilt the phone forward, back, left, right, to change direction.

Throttle and yaw control are still manually controlled from the Left Control Stick.

Attaching the Smartphone Cradle

You can use your smartphone and the remote control together by attaching the included smartphone cradle to the top of the remote. This can be useful for photography and video, or for flying the hexacopter just by watching the screen.

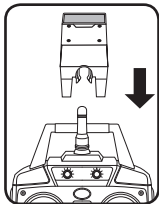

Step 1

Slide the cradle into position on the remote antenna and handle.

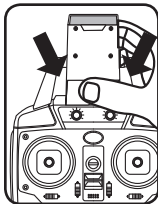

Step 2

Gently press on the cradle until it locks into place.

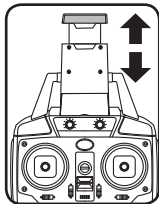

Step 3

Pull upwards on the top of the cradle so that it will fit your smartphone.

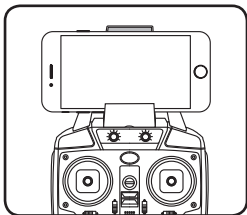

Step 4

Place your phone in the cradle and release the top portion. Your phone should sit firmly in place.

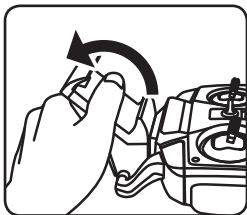

Removal

Gently pull the cradle off of the remote in a twisting motion, as shown above.

Factory Reset

Reset Procedure

If for any reason the craft is experiencing difficulty flying or is behaving erratically, and there is no physical damage to any of the mechanical components, the unit may need to be reset to the factory default settings.

Step 1

Power ON the remote control.

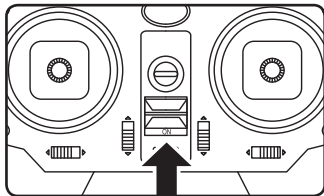

Step 2

Power on the hexacopter.

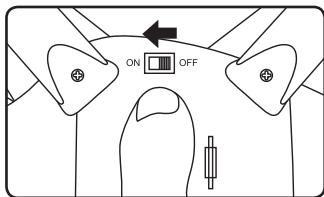

Step 3

When the LED lights on the hexacopter shift from flashing quickly to flashing slowly, push the throttle all the way forward, wait for a chime to sound, then pull the throttle all way rearward, and wait for the chime.

The lights on the hexacopter will stop flashing and change to solid.

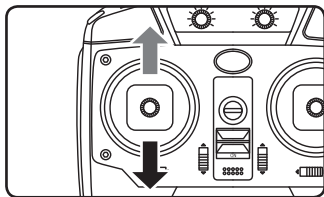

Step 4

Place the hexacopter on a flat horizontal surface, then push both control sticks on the remote all the way down and left, and hold for 2-3 seconds. The lights will begin quickly flashing again. When the lights stop flashing and are solid again, the craft has been reset and is ready to fly.

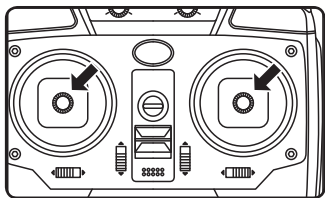

Troubleshooting

If you are experiencing problems using or flying the hexacopter, consult this table.

PROBLEM	POSSIBLE CAUSES	SOLUTION
Hexacopter is unresponsive	<ul style="list-style-type: none">• No power to remote or hexacopter• Poor contact between power plugs	<ul style="list-style-type: none">• Check remote batteries.• Check hexacopter battery, be sure it is fully charged.• Be sure the remote has an unobstructed line of sight to the hexacopter.• Be sure to remain within the remote's 250 ft. range.
Hexacopter flies erratically	<ul style="list-style-type: none">• Gyroscopes may be misaligned	<ul style="list-style-type: none">• Perform Pre-Flight Calibration again (see pg. 10).• Perform factory reset (see pg. 20)
Hexacopter drifts while in flight	<ul style="list-style-type: none">• Trim not set	<ul style="list-style-type: none">• Adjust trim settings (see pg. 11).
Hexacopter suffers from mechanical difficulty or vibrates excessively	<ul style="list-style-type: none">• Damage to body, rotors, or other major components	<ul style="list-style-type: none">• Check to make sure the hexacopter has not taken significant damage.• Replacement parts may be needed (see pg. 21).
Formation lights ON, but hexacopter no longer responds to throttle inputs	<ul style="list-style-type: none">• Low battery power	<ul style="list-style-type: none">• Recharge the battery.

Repair

In the event that the hexacopter absorbs light damage that renders flight difficult, but not impossible, the following repairs are easy to perform and should get the hexacopter back to a flyable condition.

REMINDER: Pilots are responsible for any damage caused by improper use.

Rotor Replacement

The hexacopter comes with 6 replacement rotors, to be used if the originals are broken or badly damaged.

To replace a rotor, first remove the rotor cap by gently pulling it upwards and off of the rotor. Use a small Phillips head screwdriver and remove the screw connecting the rotor to the electric motor shaft. Remove the damaged rotor and replace it with a new one, then screw it back into place on the motor shaft and replace the rotor cap.

REMINDER: It is extremely important to use the correct rotor (A or B) for replacement. Using the incorrect rotor will cause the hexacopter's flight to be erratic and impossible to control.

The marking can be seen on the bottom of the rotor, near the shaft.

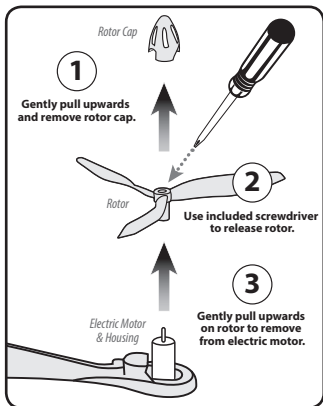

Parts

Parts Replacement

If any major components of the hexacopter are damaged beyond repair, you can order new parts by contacting the customer support number, or by following the web address below to the product page and clicking on the "Parts and Accessories" tab.

Product web address: <http://bit.ly/1kLshcF>

Parts Diagram

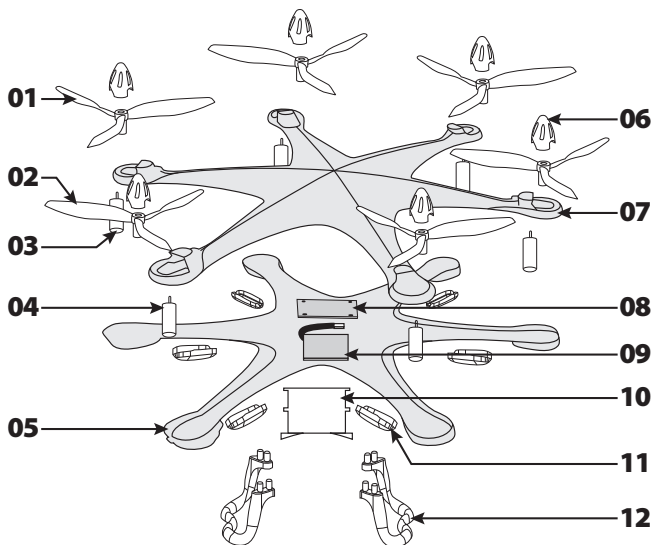

Parts List

PART	NAME	QUANTITY
1	Rotor A	3
2	Rotor B	3
3	Motor A	3
4	Motor B	3
5	Lower Frame	1
6	Rotor Cap	6
7	Upper Frame	1
8	PCB	1
9	Battery	2
10	Battery Cover	1
11	LED Cover	6
12	Landing Skid	2

Company Information

Contact Information

Website: www.gpx.com

Email Support: prodinfo@dpiinc.com

Email Parts: partsinfo@dpiinc.com

Phone Support: 1-888-999-4215

Warranty

See included 30 Day Warranty for warranty information. Warranty and the most up-to-date version of this User's Guide can also be found at: www.gpx.com

International Support

To download this User's Guide in English, Spanish, and French, or to get answers to frequently asked questions, visit the support section at: www.gpx.com

Para descargar este Manual del Usuario en inglés, español y francés, o para obtener respuestas a preguntas frecuentes, visite la sección de apoyo en: www.gpx.com

Pour télécharger ce guide de l'utilisateur en anglais, espagnol ou français, ou pour obtenir des réponses à des questions fréquemment posées, consultez la rubrique d'assistance sur: www.gpx.com



Copyright © 2015 Digital Products International (DPI, Inc.) All other trademarks appearing herein are the property of their respective owners. Specifications are subject to change without notice.
