

Wireless Outdoor Lantern + Speaker

User's Guide for Model ISBW326B v1505-01



Important Safety Instructions

- Read these Instructions.
- Keep these Instructions.
- Heed all Warnings.
- Follow all instructions.
- Clean only with a dry cloth.
- Do not block any ventilation openings. Install in accordance with the manufacturer's instructions.
- Do not install near any heat sources such as radiators, heat registers, stoves, or other apparatus (including amplifiers) that produce heat.
- Do not defeat the safety purpose of the polarized or grounding - type plug. A polarized plug has two blades with one wider than the other. A grounding type plug has two blades and a third grounding prong. The wide blade or the third prong are provided for your safety. When the provided plug does not fit into your outlet, consult an electrician for replacement of the obsolete outlet.
- Protect the power cord from being walked on or pinched particularly at plugs, convenience receptacles, and the point where they exit from the apparatus.
- Only use attachments/accessories specified by the manufacturer.
- Unplug this apparatus during lightning storms or when unused for long periods of time.
- Refer all servicing to qualified service personnel. Servicing is required when the apparatus has been damaged in any way, such as power-supply cord or plug is damaged, does not operate normally, or has been dropped.
- Use only with a cart, stand, tripod, bracket, or table specified by the manufacturer, or sold with the apparatus. When a cart is used, use caution when moving the cart/apparatus combination to avoid injury from tip-over.



FCC Warnings

Warning: Changes or modifications to this unit not expressly approved by the party responsible for compliance could void the user's authority to operate the equipment.

NOTE: This equipment has been tested and found to comply with the limits for a Class B digital device, pursuant to Part 15 of the FCC Rules. These limits are designed to provide reasonable protection against harmful interference in a residential installation. This equipment generates, uses, and can radiate radio frequency energy and, if not installed and used in accordance with the instructions, may cause harmful interference to radio communications. However, there is no guarantee that interference will not occur in a particular installation. If this equipment does cause harmful interference to radio or television reception, which can be determined by turning the equipment off and on, the user is encouraged to try to correct the interference by one or more of the following measures:

- Reorient or relocate the receiving antenna.
- Increase the separation between the equipment and receiver.
- Connect the equipment into an outlet on a circuit different from that to which the receiver is connected.
- Consult the dealer or an experienced radio/TV technician for help.

Additional Warnings and Precautions

- Caution and marking information is located at the rear or bottom of the apparatus.
- *Attention et de marquage des informations est situé sur le panneau arrière ou inférieur de l'unité.*
- Mains plug is used as disconnect device and it should remain readily operable during intended use. In order to disconnect the apparatus from the mains completely, the mains plug should be disconnected from the mains socket outlet completely.
- *La prise du secteur est utilisée pour déconnecter le système. La prise du secteur ne doit pas être obstruée ou doit être facilement accessible pendant son utilisation. Pour être complètement déconnecté de l'alimentation d'entrée, la prise doit être débranchée du secteur.*
- **CAUTION: TO PREVENT ELECTRIC SHOCK, MATCH WIDE BLADE OF PLUG TO WIDE SLOT, FULLY INSERT.**
- *AVIS: AFIN DE PRÉVENIR LES CHOCs ÉLECTRIQUES, FAITES CORRESPONDRE LA FICHE BLANCHE DE LA PRISE À LA FENTE LARGE. INSÉREZ TOTALEMENT.*
- **CAUTION:** Use of controls or adjustments, or performance of procedures other than those specified may result in hazardous radiation exposure.
- *AVIS: L'utilisation de commande ou l'exécution de procédures autres que celles spécifiées ici peuvent aboutir à une exposition à des radiations dangereuses.*
- **WARNING:** Changes or modifications to this unit not expressly approved by the party responsible for compliance could void the user's authority to operate the equipment.
- *AVIS: Des changements ou des modifications sur ce produit non expressément approuvés par la partie responsable de la conformité peut annuler le droit de l'utilisateur d'utiliser cet équipement.*
- **WARNING:** Do not place this unit directly onto furniture surfaces with any type of soft, porous, or sensitive finish. As with any rubber compound made with oils, the feet could cause marks or staining where the feet reside. We recommend using a protective barrier such as a cloth or a piece of glass between the unit and the surface to reduce the risk of damage and/or staining.
- *AVIS: Ne placez pas cette unité directement sur des surfaces de meubles dont la finition serait douce, poreuse ou sensible. Car, comme tout composé caoutchouc à base d'huiles, les pieds pourraient laisser des traces ou des taches à l'endroit où ils sont posés. Nous recommandons d'utiliser une protection comme un linge ou un morceau de verre entre l'unité et la surface pour réduire le risque de dégradation et/ou de tache.*
- **WARNING:** Lithium batteries, like all rechargeable batteries, are recyclable and should never be disposed of in normal household waste. Contact your local government for disposal or recycling practices in your area. They should never be incinerated since they might explode.
- *AVIS: Les piles au lithium, comme toutes les piles rechargeables, sont recyclables et ne doit jamais être jeté dans les ordures ménagères. Communiquez avec votre gouvernement local pour élimination ou recyclage dans votre région. Ils ne doivent jamais être incinérés car ils pourraient exploser.*
- **WARNING:** Shock hazard - Do Not Open.
- *AVIS: Risque de choc électrique - ne pas ouvrir*
- Battery shall not be exposed to excessive heat such as sunshine, fire or the like.
- *Les piles ne doivent pas être exposées à de forte chaleur, tel qu'à la lumière du soleil, au feu ou autres choses de semblable.*



WARNING: To reduce the risk of electric shock, do not remove cover (or back). No user-serviceable parts inside. Refer servicing to qualified service personnel.



The exclamation point within an equilateral triangle is intended to alert the user to the presence of important operating and maintenance (servicing) instructions in the literature accompanying the appliance.



The lightning flash with arrowhead symbol, within an equilateral triangle, is intended to alert the user to the presence of uninsulated "dangerous voltage" within the product's enclosure that may be of sufficient magnitude to constitute a risk of electric shock to persons.



This symbol indicates that this product incorporates double insulation between hazardous mains voltage and user accessible parts.

Features & Controls

- IPX4 level water resistance
- Supports Bluetooth
- Wireless range: 60 ft.
- 18 LED lantern with dimmer control
- FM Scan radio
- Aux In (3.5mm audio input)
- Carry Handle
- Micro-USB port for battery recharge
- DC power: 2000mAH rechargeable battery
- Battery life: approx. 3 hours

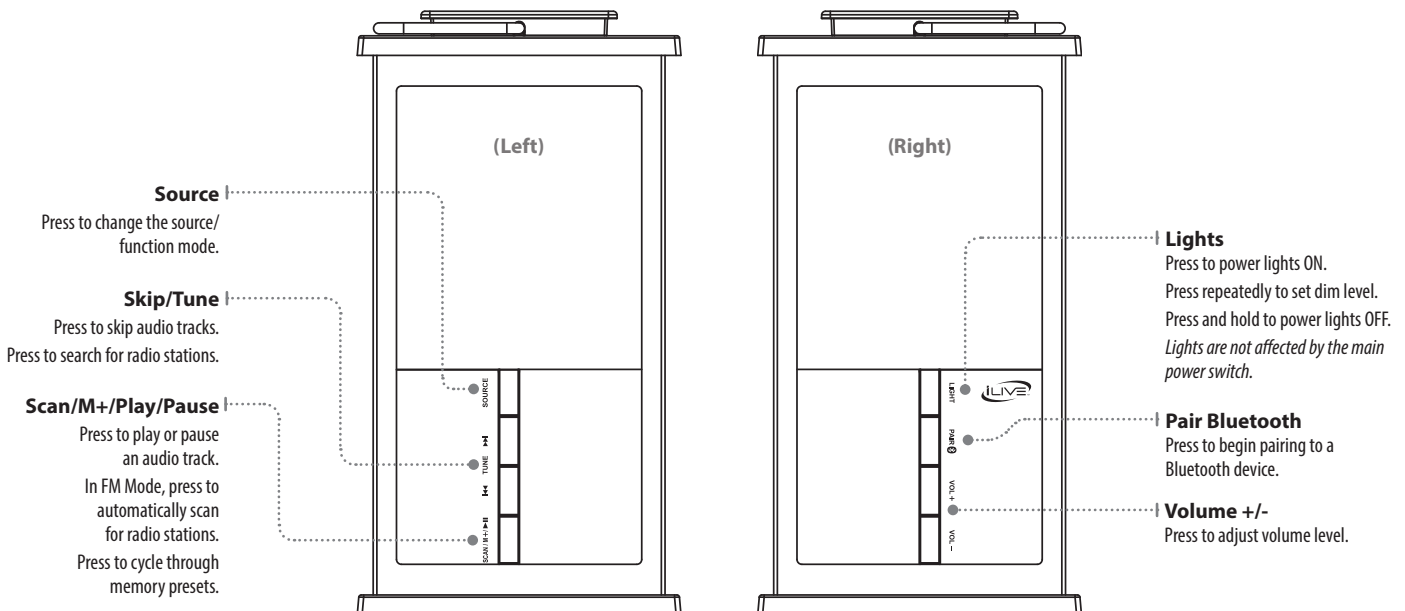
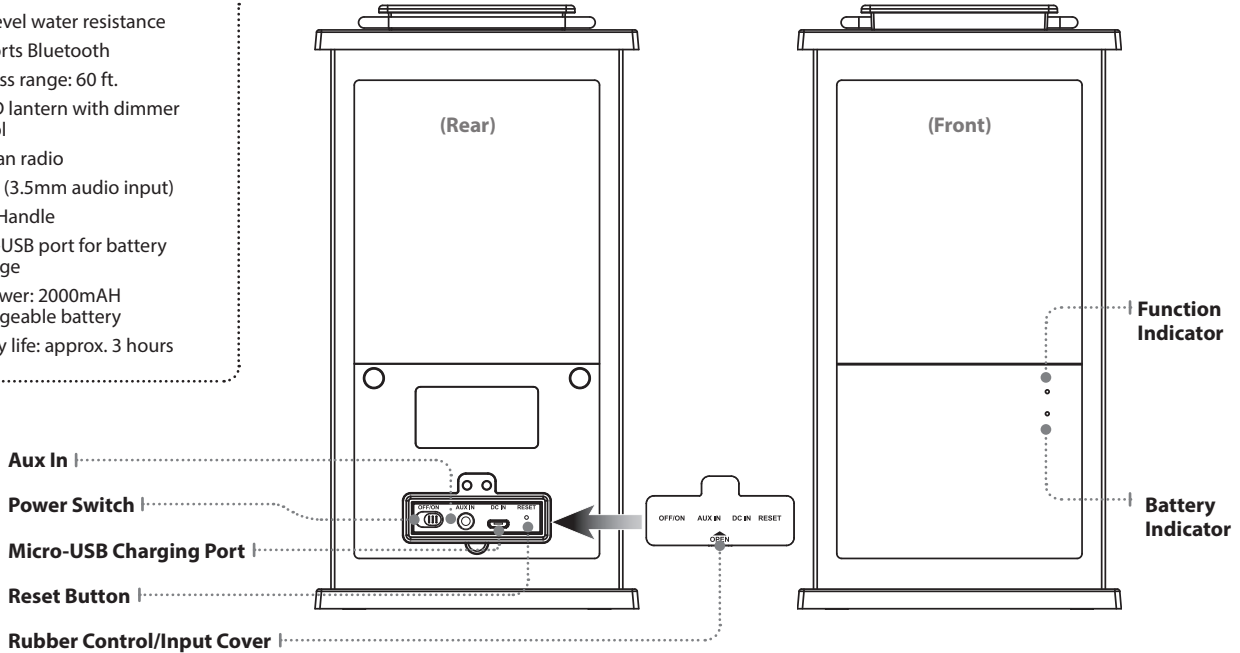

Water Resistance

This unit has a water resistance rating of IPX4. This rating is suitable for indoor and outdoor use in the presence of incidental or light exposure to splashing water, rain, or snow. Water splashing against the enclosure from any angle should have no harmful effects. It is not recommended to submerge this speaker in water for any amount of time.

IMPORTANT: To ensure your speaker is prepared for use in a wet environment, disconnect and remove any power cables, and tightly close the water cap on the rear of the unit. If the water cap is not properly closed, water resistance will be compromised and could result in damage to the speaker or personal injury.

Charging the Battery

Requires a Micro-USB to USB cable (included).

1. Using a Micro-USB to USB cable (included), connect the larger **USB plug** to the **USB port** of a powered on computer or USB power adaptor (not included).
2. Connect the smaller **Micro-USB plug** into the **Micro-USB port** on the back of the unit. The unit will now charge.

INDICATOR LIGHT	STATUS
Red light ON	Charging battery
Red light OFF	Charging complete
Red light flashing	Low Battery, charge soon

WARNING: DO NOT, UNDER ANY CIRCUMSTANCES, CHARGE THE SPEAKER WHILE IT IS NEAR WATER, AND ALLOW AMPLE TIME TO DRY AFTER BEING SPLASHED.

Bluetooth Wireless Audio

Pairing to a Device & Playing Audio

After initial pairing, the unit will stay paired unless unpaired manually by the user or erased due to a reset of the device. If your device should become unpaired or you find it is unable to connect, repeat the steps listed here.

1. Power on the unit by sliding the **POWER Switch** to the **ON** position, then press the **Source button** to set the unit to Bluetooth mode. The **pairing indicator** will slowly flash blue.
2. Press the **Pair button** to begin pairing. The **pairing indicator** will quickly flash with a dark blue light. When pairing, remain within 3 feet of the unit.
3. Using the controls on your Bluetooth device, scan for and select **ISBW326** in your Bluetooth settings to pair. If your device requests a password, enter the default password **0000**. Refer to the user's manual for your specific device for instructions on pairing and connecting Bluetooth devices.
4. When successfully paired, the **pairing indicator** will turn solid dark blue and an audible chime will sound from the speaker.
5. Use the controls on the connected device to select and begin playing audio. Audio played through the connected Bluetooth device will now be heard through the speaker.
6. Use the controls on the unit or the connected device to play, pause, and adjust volume.

FM Radio

An FM antenna is built into the unit. Adjust the position of the unit to improve radio reception.

1. Power the unit ON, then press the **Source button** to switch to FM mode.
2. Press the **Tune** buttons to manually tune to a radio station.

Programming Radio Stations

1. With the unit in **FM mode**, press and hold the **Scan/M+ button** to automatically search for stations. Stations will automatically be stored as they are scanned.
2. Press the **M+ button** to cycle through the memory presets.

Aux In

Requires a 3.5mm audio cable (not included).

1. Connect a 3.5mm audio cable to the **Aux In** on the rear of unit and the **audio output/headphone jack** on a media player or smartphone.
2. Power on the unit by sliding the **POWER Switch** to the **ON** position. The **Pairing Indicator** will light **green**.
3. Use the controls on the connected device to select and play audio.

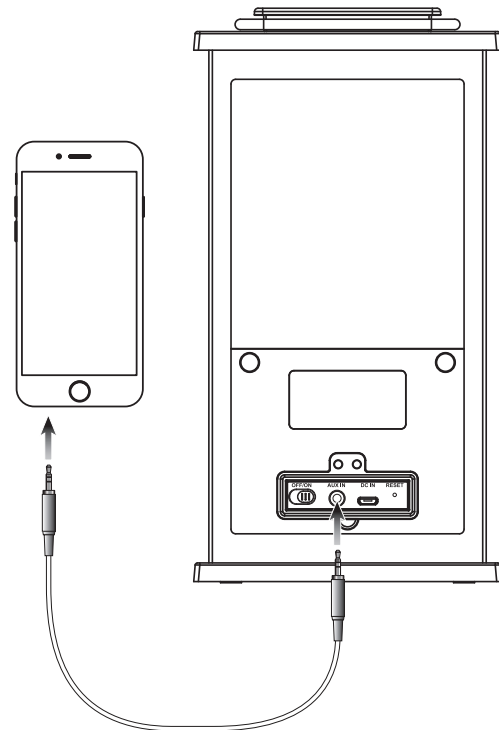

International Support

To download this User's Guide in English, Spanish, or French, or to get answers to frequently asked questions, visit the support section at: www.iLiveElectronics.com

Para descargar este Manual del Usuario en inglés, español y francés, o para obtener respuestas a preguntas frecuentes, visite la sección de apoyo en: www.iLiveElectronics.com

Pour télécharger ce guide de l'utilisateur en anglais, espagnol ou français, ou pour obtenir des réponses à des questions fréquemment posées, consultez la rubrique d'assistance sur: www.iLiveElectronics.com

For Warranty Information and the most up-to-date version of this User's Guide, go to www.iLiveElectronics.com

Customer Service: 1-888-999-4215 | **Email Support:** prodinfo@dpiinc.com | **Email Parts:** partsinfo@dpiinc.com

Copyright © 2016 Digital Products International (DPI, Inc.) All other trademarks appearing herein are the property of their respective owners. Specifications are subject to change without notice.



**Protect for Today
Sustain for Tomorrow**