

Rain Collector (# 6463 & 6463M)

This rain collector can be used with Vantage Pro2™ weather stations, including Vantage Pro2, Vantage Pro2 Plus, and the Anemometer/Sensor Transmitter Kit.



Note: Model number 6463 is factory-calibrated to take rain measurements in 0.01 inches. The metric version, 6463M, comes factory-calibrated to take measurements in 0.2 mm.

Components

The rain collector includes the following components. Please make sure you have all listed components before continuing.

- Rain collector cone latched onto base
- Base with tipping mechanism and 40' (12 m) cable
- Four #8 x 3/4" screws
- Metric adapter
- Debris Screen
- 16 3.5" bird spikes (optional).
- Metric Rain Adapter (optional): Adds weight to the tipping mechanism, adjusting it to tip for every 0.2 mm of rainfall instead of every 0.01".

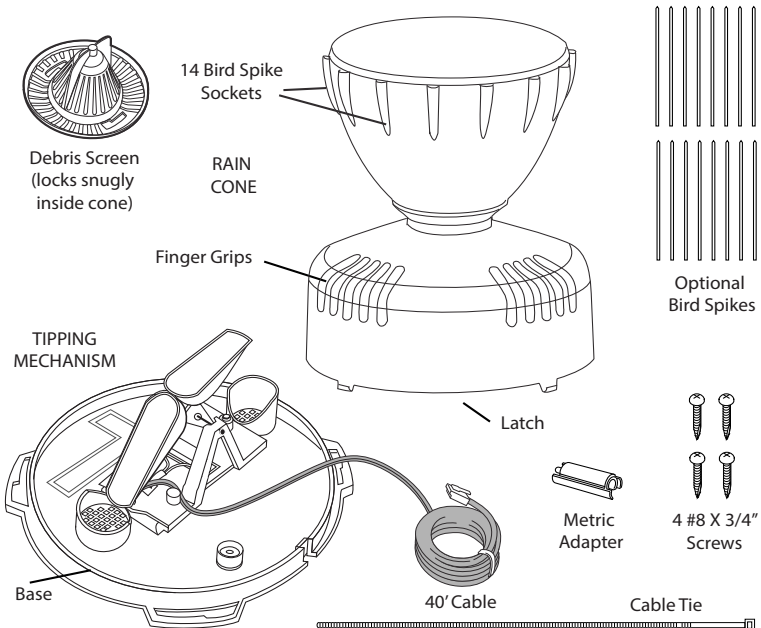

Tools and Materials Needed

You may need some of the following tools and materials to install the rain collector.

- Drill with 3/32" (2 mm) drill bit
- Medium Phillips screwdriver
- 3/16" (or 5 mm) wrench
- Cable clips or weather-resistant cable ties with screw holes or other means for mounting
- Small hammer (for optional bird spikes)

Rain Collector Internal Components

The illustration below shows the internal components of the rain collector, many of which are referenced in this manual.

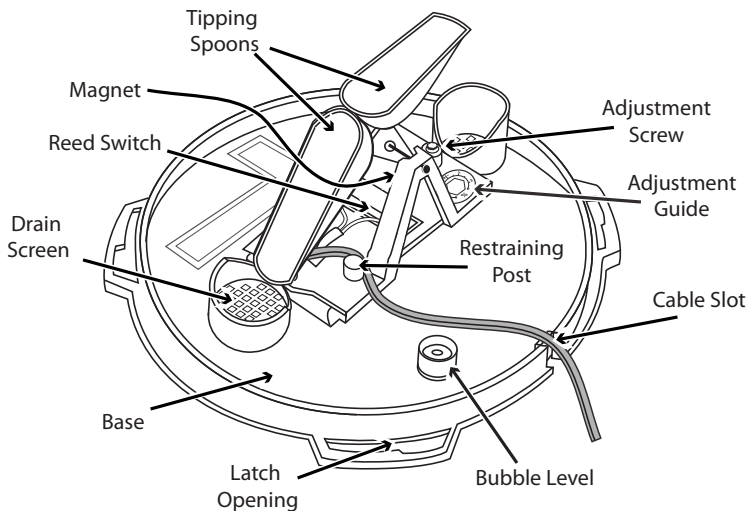

Prepare the Rain Collector

1. Turn the rain collector upside down and remove the cone from the base by rotating the base until the latches on the cone line up with the latch openings in the base then lifting the base away from the cone.
2. Carefully cut and remove the plastic tie which holds the tipping spoons in place during shipping.
3. Insert the optional metric measurement adapter if needed. (See instructions below.)

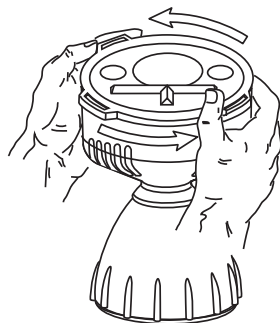

Insert the Optional Metric Measurement Adapter

Note: The metric version of the rain collector, product number 7852M, comes factory calibrated to take measurements in 0.2 mm. There is no need to install the metric measurement adapter.

If you have purchased a US version, the rain collector tipping mechanism contains a standard measurement weight magnet that takes measurements in 0.01" for every tip of the spoons. If you would prefer readings in metric units rather than inches, you can configure your console to convert the readings to millimeters.

For the greatest accuracy, you may also install the included metric adapter so that the rain collector will take measurements in 0.2 mm for each tip of the bucket.

Whether you install the adapter or not, you must configure the console to display mms. (Press either RAIN key. Press and release 2ND, then press UNITS once.)

1. Locate the standard measurement weight magnet between the arms of the tipping mechanism.
2. Open the arms slightly with one hand while pulling the magnet out with the other hand. Separate an end cap from one side of the magnet.

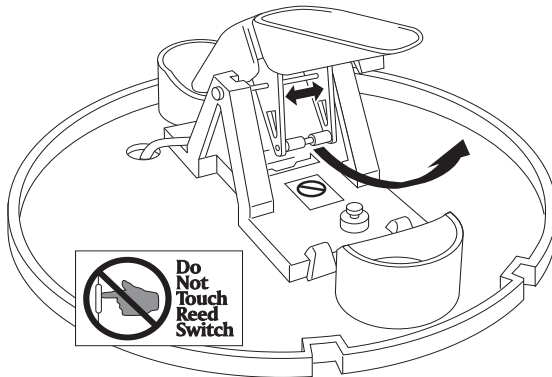

3. Slide the magnet, with the exposed end of the magnet first, into the open slot of the metric measurement adapter.
4. Insert the metric measurement adapter between the arms of the tipping bucket, with solid side of the metric measurement facing up.

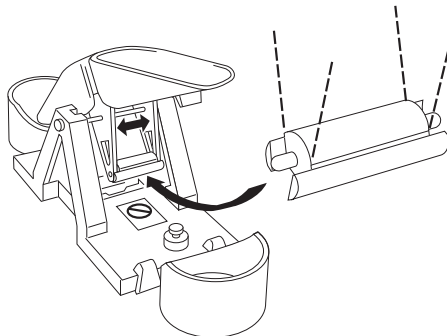

Test the Rain Collector

Before installing the rain collector, test the unit. If you are replacing a rain collector you previously installed, make a note of the total rainfall amount displayed. You may want to reenter this amount after you test the rain collector.

1. Open the transmitter shelter on the ISS. Remove the foam insert and feed the rain collector cable up through the opening. Plug the cable to the appropriate connector in the sensor interface (See illustration on page 5.)
2. Press the RAINDAY button on your console to display rainfall.
3. While watching the display on your console to see if it changes, slowly tip the bucket until it drops to the opposite side. Each tip indicates 0.01" or 0.2 mm of rain. (It may take up to a minute for the first tip to register at the console.) If the display does not change, you may be tipping the bucket too quickly. Try again, more slowly this time. If the rainfall amount displayed on the console increases by the expected increment (either 0.01" or 0.2 mm) each time you tip the bucket, your rain collector is working properly.

Install the Rain Collector

Note: Climbing on your roof may be hazardous. If you are uneasy about installing your unit please have a qualified professional complete the installation. Davis specifically disclaims any liability for injury or loss resulting from the installation or use of the rain collector.

Choosing a Location for the Rain Collector

Keep the following in mind when choosing a location for your rain collector:

- You must mount the rain collector so that it is level. A built-in bubble level is attached to the base to simplify this process.
- Be sure there is an unobstructed path for water runoff from the drain screens.
- The rain collector contains a magnet-operated switch which may not operate correctly if you mount the rain collector on or near any object which is attracted to a magnet.
- Exposure to winds can reduce the measured rainfall amounts. Mount the rain collector where there are no obstructions of rainfall at low angles -- such as trees, houses, fences -- and as low as possible out of the wind.

To install the rain collector on a sheet metal roof, insulate the unit by making a platform out of wood. Mount the base of the rain collector at least 1" (4 cm) away from any steel or iron surface and make sure the reed switch is at least 1" (4 cm) away from any steel or iron objects (e.g., nails).

- Choose a location which is easily accessible for normal cleaning and is distant from trees or other sources of heavy pollen or debris.

Installing the Rain Collector

The following instructions assume the rain collector is being used with a Vantage Pro2 or Vantage Pro2 Plus ISS. Refer to the user manual that came with your station for more information.

Tip: *Manuals are available online at www.davisnet.com.*

1. If you have not already done so, separate the cone from the base and disconnect the rain collector cable from the sensor interface in the transmitter shelter.
2. Place the base on the mounting surface and mark the location of the four holes (the base has eight to choose from) you will use to secure the base.
3. Make pilot holes using a 3/32" (2 mm) drill bit. You should make the pilot holes about 1/2" (12 mm) deep.
4. Fasten the base to the mounting surface using the #8 x 3/4" screws provided.

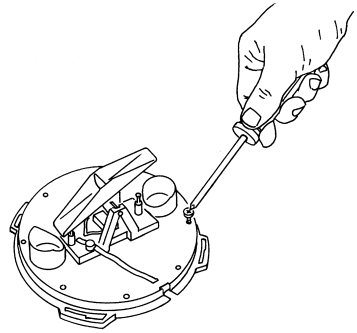

5. Open the transmitter shelter on the ISS. Remove the foam insert and feed the rain collector cable up through the opening. Plug the cable to the appropriate connector. Replace the foam and close the shelter.

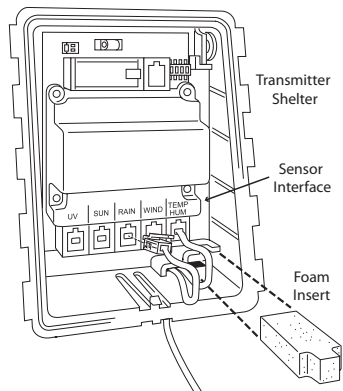

6. To be certain the rain collector is functioning properly after installation, retest the unit. See "Insert the Optional Metric Measurement Adapter" on page 3.

- To use the bird spikes, insert one spike in each socket around the rim of the cone. The sockets are tapered: push firmly or tap lightly with a hammer for a more secure fit.
- Place the cone back onto the base by putting the latches on the cone into the latch openings in the base and rotating the cone clockwise until the latches “lock” into place. As you reattach the cone, make sure to run the cable to the cable slot in the base, or the cone will not fit snugly against the base.
- Place the debris screen, pointed end up, into the cone. Align the locking grooves with the locks inside the cone and turn to lock the screen in place. If bird nesting is a problem, you can place a spike in the hole on top of the debris screen. Be careful; bird spikes may be sharp.

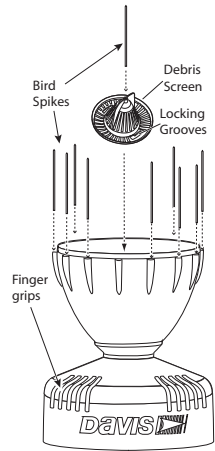

Tip: If you choose not to install bird spikes, keep the packet of spikes for possible future use.

- To prevent fraying or cutting of the cable where it is exposed to weather, it is important that you secure it so it doesn't whip about in the wind. Use cable clips or weather resistant cable ties to secure the cable. Place clips or ties approximately every 3 to 5 feet (1 to 1.6 m). Do not use metal staples or a staple gun to secure cables. Metal staples—especially when installed with a staple gun—have a tendency to cut the cables.

Extending Cable Runs

If the cable length supplied with the rain collector is not long enough for your purposes, you may extend it. The maximum length of cable is 900 feet (274 m). To extend the cable, purchase standard 4-Conductor Extension Cables from Davis and connect them to the existing rain collector cable.

Adjusting the Rain Collector

The non-metric version of the rain collector is calibrated at the factory so the spoons tip (and records rainfall) for each 0.01". The metric version is calibrated so the spoons tip for each 0.2 mm of rain. To adjust the calibration slightly, use a 3/16" (or 5 mm) wrench to rotate the adjustment screws which are located underneath the tipping spoons. (See “Rain Collector Internal Components” on page 2.) The adjustment guide embossed in the platform shows how far you must rotate both screws in turn to effect a 1% and a 2% change. Moving the screws in the positive (+) direction causes the spoons to tip more times (i.e. give a larger count) for a given amount of water.

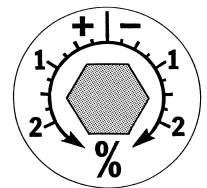

Note: Modify both adjustment screws by the same amount.

To check the accuracy of the rain collector, compare the Davis rain collector with a tube type rain gauge. Use a rain gauge with an aperture of at least 4 inches. Any smaller and the readings obtained may not be accurate. Place the tube type rain gauge directly next to the Davis rain collector. Compare the totals on three storms to determine whether your rain collector needs calibration and by how much. Adjust the screws to fine-tune the reading for the next three storms if necessary.

Note: Avoid comparison to rainfall readings obtained from television, radio, newspapers, or neighbors' readings. Such readings are not an accurate measurement of the weather conditions in your specific location. The rain collector is carefully tested at the factory to conform to the specifications listed in the back of this manual.

Maintaining the Rain Collector

For greatest accuracy, you should thoroughly clean the rain collector at least once or twice a year.

1. Disconnect the rain collector cable from the sensor interface in the transmitter shelter.
2. Separate the cone from the base.
3. Use a soft damp cloth to clean pollen, dirt, and other debris from the cone, cone screens, and bucket.
4. Use a pipe cleaner to clear the funnel hole in the cone and the drain screens in the base. When all parts are clean, rinse with clear water.
5. Reattach the cone and replace the debris screen.
6. Reconnect the rain collector cable to the sensor interface.

Troubleshooting Guide

Rainfall is not registering on the console or the console has a large error.

- Check the cable connections from the sensor to the console. Cable connections account for a large portion of the potential problems. Connections should be firmly seated in the jacks and plugged in straight. If you think a connection may be faulty, try jiggling the cable while looking at the display. If a reading appears intermittently on the display as you jiggle the cable, the connection is faulty.
- Make sure there is no magnetic, steel, or iron object near the rain collector.
- Make sure the funnel hole in the cone is clear so water can empty into the bucket.
- Make sure the spoons move freely when tipping to *both sides*. The console should show an increase in rainfall for each tip of the spoons. (If the spoons do not move at all, check that you have cut the cable tie that holds them in place during shipping.)
- Make sure the rain collector is mounted so that it is level.
- Use the adjustment screws (See “Adjusting the Rain Collector” on page 6) to adjust the rain collector’s sensitivity, if necessary.

Contacting Davis Technical Support

If you have questions about your rain collector, or encounter problems installing or operating it, please contact Davis Technical Support.

Note: Please do not return items to the factory for repair without prior authorization.

Online: www.davisnet.com
See copies of user manuals, product specifications, application notes, software updates, and more.

E-mail: support@davisnet.com

Telephone: (510) 732-7814
Monday – Friday, 7:00 a.m. – 5:30 p.m. Pacific Time.

Specifications

Sensor Type	Tipping bucket with magnetic switch
Output	Contact closure
Attached Cable Length	40' (12 m)
Cable Type	4-conductor, 26 AWG
Connector	Modular connector (RJ-11)
Recommended Max. Cable Length	900' (270 m)
Housing Material	UV-stabilized ABS plastic
Dimensions	
Rain Collector and base	8.75" diameter x 9.5" high (22.2 cm diameter x 24 cm high)
Collection Area	33.2 in ² (214 cm ²)
Range	
Daily Rainfall	0.00" to 99.99" (0.0 mm to 999.8 mm)
Total Rainfall	0.00" to 199.99" (0.0 mm to 6553 mm)
Accuracy	For rain rates up to 2"/hr (50 mm/hr): ±4% of total or +0.01" (0.2mm) (0.01" = one tip of the bucket), whichever is greater. For rain rates from 2"/hr (50 mm/hr) to 4"/hr (100 mm/hr): ±5% of total or +0.01" (0.2mm) (0.01" = one tip of the bucket), whichever is greater.
Update Interval	20-24 seconds
Input/Output Connections	
Red	Switch terminal
Green & Yellow	Switch terminal

Product Number: 6463 Rain Collector

Part Number: 07395.295

Rev A (3/8/17)

This product complies with the essential protection requirements of the EC EMC Directive 2004/108/EC.

Copyright © 2017 Davis Instruments Corp. All rights reserved. Davis Instruments Quality Management System is ISO 9001 certified. Information in this document is subject to change without notice.

DAVIS ®
Davis Instruments

3465 Diablo Avenue, Hayward, CA 94545-2778 U.S.A.

510-732-9229 • Fax: 510-732-9188

E-mail: info@davisnet.com • www.davisnet.com