

eS Series

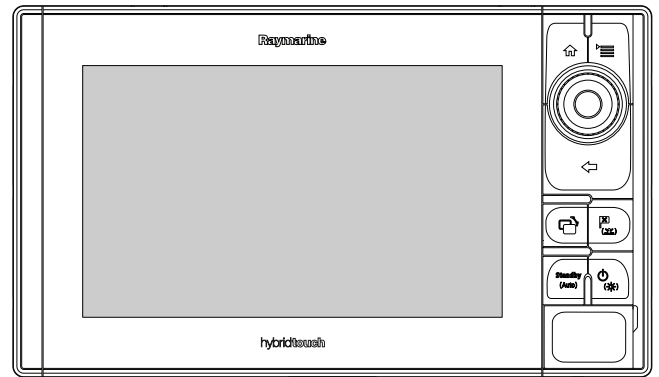

Installation instructions

English

Date: 05-2015

Document number: 87250-1-EN

© 2015 Raymarine UK Limited

Trademark and patents notice

Raymarine, Tacktick, Clear Pulse, Truzoom, HSB, SeaTalk, SeaTalk^{hs}, SeaTalk^{ng}, Micronet, Raytech, Gear Up, Marine Shield, Seahawk, Autohelm, Automagic, and Visionality are registered or claimed trademarks of Raymarine Belgium.

FLIR, DownVision, SideVision, Dragonfly, Instalert, Infrared Everywhere, and The World's Sixth Sense are registered or claimed trademarks of FLIR Systems, Inc.

All other trademarks, trade names, or company names referenced herein are used for identification only and are the property of their respective owners.

This product is protected by patents, design patents, patents pending, or design patents pending.

Fair Use Statement

You may print no more than three copies of this manual for your own use. You may not make any further copies or distribute or use the manual in any other way including without limitation exploiting the manual commercially or giving or selling copies to third parties.

Software updates

Check the website www.raymarine.com for the latest software releases for your product.

Product handbooks

The latest versions of all English and translated handbooks are available to download in PDF format from the website www.raymarine.com.

Please check the website to ensure you have the latest handbooks.

Copyright ©2015 Raymarine UK Ltd. All rights reserved.

Contents

Chapter 1 Important information.....	7	4.12 GNSS / GPS connection.....	44
Certified Installation	7	4.13 AIS connection.....	45
TFT Displays.....	8	4.14 Fastheading connection.....	45
Water ingress.....	8	4.15 Keypad network connection	46
Disclaimers	8	4.16 Weather receiver connection.....	46
RF exposure	9	4.17 HDMI video output	47
FCC.....	9	4.18 Video connection — composite	47
Compliance Statement (Part 15.19)	9	4.19 IP Camera connection	48
FCC Interference Statement (Part 15.105 (b))	9	4.20 Thermal camera connection.....	49
Industry Canada	9	4.21 Fusion network connection	50
Industry Canada (Français)	9	4.22 Fusion NMEA 2000 connection	51
Japanese approvals.....	9	4.23 Media player connection.....	51
Declaration of conformity.....	9	4.24 Raymarine mobile app connection.....	52
Product disposal.....	10	4.25 Bluetooth remote control connection.....	53
Pixel defect policy.....	10	Chapter 5 Mounting.....	57
Warranty registration.....	10	5.1 Surface mounting.....	58
IMO and SOLAS.....	10	5.2 Bracket (trunnion) mounting.....	59
Technical accuracy	10	5.3 Rear flush mount kit	60
Chapter 2 Document and product information.....	11	Chapter 6 Getting started	61
2.1 Document information	12	6.1 Switching the unit on and off	62
2.2 Applicable products.....	12	6.2 eS Series Controls	63
2.3 Product documentation.....	13	6.3 Basic touchscreen operations	64
2.4 Document illustrations	13	6.4 Multi-Touch gestures	64
2.5 Product overview - eS Series	14	6.5 Touch icons	65
Chapter 3 Planning the installation	15	6.6 Homescreen overview — HybridTouch and non-Touch displays.....	65
3.1 System integration	16	6.7 Pages	67
3.2 Installation checklist	22	6.8 Applications.....	69
3.3 Multiple data sources (MDS) overview.....	22	6.9 Splitscreen controls.....	70
3.4 Identifying your display variant	23	6.10 Screen overview	71
3.5 Networking constraints	23	6.11 Initial set up procedures	74
3.6 System protocols	24	6.12 GNSS Status	76
3.7 Data master.....	25	6.13 Enabling autopilot control.....	79
3.8 Parts supplied — eS7x displays	26	6.14 Engine identification	80
3.9 Parts supplied — eS9x and eS12x displays	26	6.15 Enabling AIS functions.....	82
3.10 Tools required for installation.....	27	6.16 Shared preferences.....	82
3.11 Selecting a location	27	6.17 Memory cards and chart cards	83
Chapter 4 Cables and connections.....	31	6.18 Simulator mode.....	83
4.1 General cabling guidance	32	6.19 Pairing the keypad	84
4.2 Connections overview	33	6.20 System software updates.....	84
4.3 3–pin power connection.....	34	6.21 Learning resources.....	86
4.4 Power and data (combined) connection	34	Chapter 7 System checks	87
4.5 SeaTalk^{ng} connections	36	7.1 GPS Check.....	88
4.6 NMEA 2000 connection	37	7.2 Radar check	88
4.7 SeaTalk connection.....	38	7.3 Sonar check	89
4.8 NMEA 0183 connection — Power/NMEA/Video cable.....	38	7.4 Thermal camera setup and checks.....	91
4.9 Sonar module and transducer connection	40	Chapter 8 Maintaining your display.....	93
4.10 Radar network connection	41	8.1 Service and maintenance	94
4.11 GA150 connection.....	44	8.2 Product cleaning	94

Chapter 9 Troubleshooting	95	Appendix A Connectors and pinouts	139
9.1 Troubleshooting	96	Appendix B NMEA 0183 sentences	141
9.2 Power up troubleshooting	97	Appendix C NMEA data bridging	142
9.3 Radar troubleshooting	98	Appendix D NMEA 2000 sentences	143
9.4 GPS troubleshooting	99		
9.5 Sonar troubleshooting	100		
9.6 Sonar crosstalk interference	103		
9.7 Thermal camera troubleshooting	105		
9.8 System data troubleshooting	107		
9.9 Video troubleshooting	108		
9.10 Wi-Fi troubleshooting	109		
9.11 Bluetooth troubleshooting	110		
9.12 Touchscreen troubleshooting	111		
9.13 Touchscreen alignment	112		
9.14 Miscellaneous troubleshooting	113		
Chapter 10 Technical specification	115		
10.1 Product dimensions	116		
10.2 Weight specification - eS Series	116		
10.3 Power specification — eS7x displays	117		
10.4 Power specification — eS9x displays	117		
10.5 Power specification — eS12x displays	118		
10.6 Display specification — eS7x displays	118		
10.7 Display specification — eS9x displays	119		
10.8 Display specification — eS12x displays	119		
10.9 Data connections and storage — eS7x displays	120		
10.10 Data connections and storage — eS9x and eS12x displays	120		
10.11 Environmental specification	121		
10.12 Internal GNSS (GPS / GLONASS) receiver specification	121		
10.13 Internal 600 W sonar specification	122		
10.14 Internal CHIRP DownVision™ specification	122		
10.15 Electronic chart specification	123		
10.16 Conformance specification	123		
Chapter 11 Technical support	125		
11.1 Raymarine customer support	126		
11.2 Learning resources	126		
11.3 Third-party support	127		
Chapter 12 Spares and accessories	129		
12.1 eS Series spares and accessories	130		
12.2 Digital ClearPulse Transducers and accessories	130		
12.3 DownVision™ transducers and accessories	131		
12.4 Network hardware	132		
12.5 Network cable connector types	133		
12.6 RayNet to RayNet cables and connectors	135		
12.7 Network cable types	136		
12.8 SeaTalk ^{ng} cabling components	136		
12.9 SeaTalk ^{ng} cables and accessories	137		

Chapter 1: Important information

Certified Installation

Raymarine recommends certified installation by a Raymarine approved installer. A certified installation qualifies for enhanced product warranty benefits. Contact your Raymarine dealer for further details, and refer to the separate warranty document packed with your product.



Warning: Product installation and operation

This product must be installed and operated in accordance with the instructions provided. Failure to do so could result in personal injury, damage to your vessel and/or poor product performance.



Warning: Potential ignition source

This product is NOT approved for use in hazardous/flammable atmospheres. Do NOT install in a hazardous/flammable atmosphere (such as in an engine room or near fuel tanks).



Warning: High voltages

This product may contain high voltages. Do NOT remove any covers or otherwise attempt to access internal components, unless specifically instructed in the documentation provided.



Warning: Product grounding

Before applying power to this product, ensure it has been correctly grounded, in accordance with the instructions provided.



Warning: Switch off power supply

Ensure the vessel's power supply is switched OFF before starting to install this product. Do NOT connect or disconnect equipment with the power switched on, unless instructed in this document.



Warning: FCC Warning (Part 15.21)

Changes or modifications to this equipment not expressly approved in writing by Raymarine Incorporated could violate compliance with FCC rules and void the user's authority to operate the equipment.



Warning: Radar transmission safety

The radar scanner transmits electromagnetic energy. Ensure all personnel are clear of the scanner when the radar is transmitting.



Warning: Sonar operation

- NEVER operate the sonar with the vessel out of the water.
- NEVER touch the transducer face when the sonar is powered on.
- SWITCH OFF the sonar if divers are likely to be within 7.6 m (25 ft) of the transducer.



Warning: Touchscreen display temperature

If the display is mounted where it will be exposed to prolonged periods of direct sunlight, the touchscreen may get very hot due to the absorbed solar energy.

In such conditions Raymarine highly recommends that you avoid using the touchscreen:

- For HybridTouch displays, use the integrated keypad to operate the display.
- For touch-only systems it is recommended that an external keypad is fitted to the system (for example, the RMK-9 accessory).



Warning: Touchscreen display

Exposure to prolonged rain may cause erroneous touch performance, in these situations keep touch activity to a minimum and wipe the screen with a dry non-abrasive cloth before using the touchscreen.

Caution: Transducer cable

- Do NOT cut, shorten, or splice the transducer cable.
- Do NOT remove the connector.

If the cable is cut, it cannot be repaired. Cutting the cable will also void the warranty.

Caution: Mounting surface requirements

This product is heavy. To prevent potential damage to the product and / or your vessel, observe the following BEFORE installing the product:

- Refer to the weight information provided in the technical specification for this product and ensure that the intended mounting surface is suitable for bearing the weight.
- If the mounting surface is not suitable for the product weight, you may need to reinforce the mounting surface.
- If in doubt, refer to a professional marine equipment installer for further guidance.

Caution: Power supply protection

When installing this product ensure the power source is adequately protected by means of a suitably-rated fuse or automatic circuit breaker.

Caution: Care of chart and memory cards

To avoid irreparable damage to and / or loss of data from chart and memory cards:

- DO NOT save data or files to a card containing cartography as the charts may be overwritten.
- Ensure that chart and memory cards are fitted the correct way around. DO NOT try to force a card into position.
- DO NOT use a metallic instrument such as a screwdriver or pliers to insert or remove a chart or memory card.

Caution: Ensure card reader door is securely closed

To prevent water ingress and consequent damage to the product, ensure that the card reader door is firmly closed.

Caution: Sun covers

- If your product is supplied with a sun cover, to protect against the damaging effects of ultraviolet (UV) light, always fit the sun cover when the product is not in use.
- Sun covers must be removed when travelling at high speed, whether in water or when the vessel is being towed.

Caution: Product cleaning

When cleaning products:

- If your product includes a display screen, do NOT wipe the screen with a dry cloth, as this could scratch the screen coating.
- Do NOT use abrasive, or acid or ammonia based products.
- Do NOT use a jet wash.

TFT Displays

The colors of the display may seem to vary when viewed against a colored background or in colored light. This is a perfectly normal effect that can be seen with all color Thin Film Transistor (TFT) displays.

Water ingress

Water ingress disclaimer

Although the waterproof rating capacity of this product meets the stated IPX standard (refer to the product's *Technical Specification*), water intrusion and subsequent equipment failure may occur if the product is subjected to commercial high-pressure washing. Raymarine will not warrant products subjected to high-pressure washing.

Disclaimers

This product (including the electronic charts) is intended to be used only as an aid to navigation. It is designed to facilitate use of official government charts, not replace them. Only official government charts and notices to mariners contain all the current information needed for safe navigation, and the captain is responsible for their prudent use. It is the user's responsibility to use official government charts, notices to mariners, caution and proper navigational skill when operating this or any other Raymarine product. This product supports electronic charts provided by third party data suppliers which may be embedded or stored on memory card. Use of such charts is subject to the supplier's End-User Licence Agreement included in the documentation for this product or supplied with the memory card (as applicable).

Raymarine does not warrant that this product is error-free or that it is compatible with products manufactured by any person or entity other than Raymarine.

This product uses digital chart data, and electronic information from the Global Positioning System (GPS) which may contain errors. Raymarine does not warrant the accuracy of such information and you are advised that errors in such information may cause the product to malfunction. Raymarine is not responsible for damages or injuries caused by your use or inability to use the product, by the interaction

of the product with products manufactured by others, or by errors in chart data or information utilized by the product and supplied by third parties.

RF exposure

This equipment complies with FCC / IC RF exposure limits for general population / uncontrolled exposure. The wireless LAN / Bluetooth antenna is mounted behind the front facia of the display. This equipment should be installed and operated with a minimum distance of 1 cm (0.39 in) between the device and the body. This transmitter must not be co-located or operating in conjunction with any other antenna or transmitter, except in accordance with FCC multi-transmitter product procedures.

FCC

Compliance Statement (Part 15.19)

This device complies with Part 15 of the FCC Rules. Operation is subject to the following two conditions:

1. This device may not cause harmful interference.
2. This device must accept any interference received, including interference that may cause undesired operation.

FCC Interference Statement (Part 15.105 (b))

This equipment has been tested and found to comply with the limits for a Class B digital device, pursuant to Part 15 of the FCC Rules.

These limits are designed to provide reasonable protection against harmful interference in a residential installation. This equipment generates, uses, and can radiate radio frequency energy and, if not installed and used in accordance with the instructions, may cause harmful interference to radio communications. However, there is no guarantee that interference will not occur in a particular installation. If this equipment does cause harmful interference to radio or television reception, which can be determined by turning the equipment off and on, the user is encouraged to try to correct the interference by one of the following measures:

1. Reorient or relocate the receiving antenna.
2. Increase the separation between the equipment and receiver.
3. Connect the equipment into an outlet on a circuit different from that to which the receiver is connected.
4. Consult the dealer or an experienced radio / TV technician for help.

Industry Canada

This device complies with Industry Canada License-exempt RSS standard(s).

Operation is subject to the following two conditions:

1. This device may not cause interference; and
2. This device must accept any interference, including interference that may cause undesired operation of the device.

This Class B digital apparatus complies with Canadian ICES-003.

Industry Canada (Français)

Cet appareil est conforme aux normes d'exemption de licence RSS d'Industry Canada.

Son fonctionnement est soumis aux deux conditions suivantes:

1. cet appareil ne doit pas causer d'interférence, et
2. cet appareil doit accepter toute interférence, notamment les interférences qui peuvent affecter son fonctionnement.

Cet appareil numérique de la classe B est conforme à la norme NMB-003 du Canada.

Japanese approvals

In the frequency band used for this device, campus radio stations (radio stations that require a license) and specified low power radio stations (radio stations that do not require license) for mobile identification and amateur radio stations (radio stations that require license) used in industries such as microwave ovens, scientific, medical equipment devices and production line of other factories are also being operated.

1. Before using this device, please make sure that campus radio stations and specified low power radio stations for mobile identification and amateur radio stations are not being operated nearby.
2. In case there is any case of harmful interference to campus radio stations for mobile identification caused by this device, please immediately change the frequency used or stop the transmission of radio waves and then consult about the measures to avoid interference (for example, the installation of partitions) through the contact information below.
3. Besides, when in trouble, such as when there is any case of harmful interference to specified low power radio stations for mobile identification or amateur radio stations caused by this device, please consult through the following contact information.

Contact information: Please contact your local authorized Raymarine dealer.

Declaration of conformity

Raymarine UK Ltd. declares that this product is compliant with the essential requirements of R&TTE directive 1999/5/EC.

The original Declaration of Conformity certificate may be viewed on the relevant product page at www.raymarine.com.

Product disposal

Dispose of this product in accordance with the WEEE Directive.



The Waste Electrical and Electronic Equipment (WEEE) Directive requires the recycling of waste electrical and electronic equipment.

Pixel defect policy

In common with all TFT units, the screen may exhibit a few wrongly-illuminated (“dead”) pixels. These may appear as black pixels in a light area of the screen or as colored pixels in black areas.

If your display exhibits MORE than the number of wrongly-illuminated pixels allowed (refer to the product *technical specification* for details), please contact your local Raymarine service center for further advice.

Warranty registration

To register your Raymarine product ownership, please visit www.raymarine.com and register online.

It is important that you register your product to receive full warranty benefits. Your unit package includes a bar code label indicating the serial number of the unit. You will need this serial number when registering your product online. You should retain the label for future reference.

IMO and SOLAS

The equipment described within this document is intended for use on leisure marine boats and workboats NOT covered by International Maritime Organization (IMO) and Safety of Life at Sea (SOLAS) Carriage Regulations.

Technical accuracy

To the best of our knowledge, the information in this document was correct at the time it was produced. However, Raymarine cannot accept liability for any inaccuracies or omissions it may contain. In addition, our policy of continuous product improvement may change specifications without notice. As a result, Raymarine cannot accept liability for any differences between the product and this document. Please check the Raymarine website (www.raymarine.com) to ensure you have the most up-to-date version(s) of the documentation for your product.

Chapter 2: Document and product information

Chapter contents

- [2.1 Document information on page 12](#)
- [2.2 Applicable products on page 12](#)
- [2.3 Product documentation on page 13](#)
- [2.4 Document illustrations on page 13](#)
- [2.5 Product overview - eS Series on page 14](#)

2.1 Document information

This document contains important information related to the installation of your Raymarine product.



The document includes information to help you:

- plan your installation and ensure you have all the necessary equipment;
- install and connect your product as part of a wider system of connected marine electronics;
- troubleshoot problems and obtain technical support if required.

This and other Raymarine product documents are available to download in PDF format from www.raymarine.com.

2.2 Applicable products

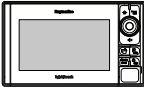
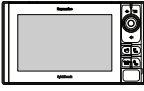
This document is applicable to the following products:

	Chart Plotter	600 W Sonar	CHIRP DownVision™
	eS75 E70263	eS77 E70264	eS78 E70265
	N/A	eS97 E70274	eS98 E70275
	N/A	eS127 E70284	eS128 E70285

2.3 Product documentation

The following documentation is applicable to your product:

All documents are available to download as PDFs from www.raymarine.com

Documentation

Description	Part number
eS Series Installation instructions	87250
LightHouse™ multifunction display operation instructions	81360
eS Series Rear mounting bracket installation instructions	87249
eS7x Surface mounting template	87234
eS9x Surface mounting template	87235
eS12x Surface mounting template	87236

Additional documentation

Description	Part number
SeaTalk ^{ng} reference manual	81300
RMK-9 Installation and operations instructions	81351

User manuals Print Shop

Raymarine provides a Print Shop service, enabling you to purchase a high-quality, professionally-printed manual for your Raymarine product.

Printed manuals are ideal for keeping onboard your vessel, as a useful source of reference whenever you need assistance with your Raymarine product.

Visit <http://www.raymarine.co.uk/view/?id=5175> to order a printed manual, delivered directly to your door.

For further information about the Print Shop, please visit the Print Shop FAQ pages: <http://www.raymarine.co.uk/view/?id=5751>.

Note:

- Accepted methods of payment for printed manuals are credit cards and PayPal.
- Printed manuals can be shipped worldwide.
- Further manuals will be added to the Print Shop over the coming months for both new and legacy products.
- Raymarine user manuals are also available to download free-of-charge from the Raymarine website, in the popular PDF format. These PDF files can be viewed on a PC / laptop, tablet, smartphone, or on the latest generation of Raymarine multifunction displays.

2.4 Document illustrations

Products may differ slightly from those shown in the illustrations in this document, depending on product variant and date of manufacture.

The illustration shown below is used throughout this document to represent **LightHouse™** powered **MFDs** and unless otherwise stated applies to all multifunction display variants.



2.5 Product overview - eS Series

Your multifunction display includes the features listed below.

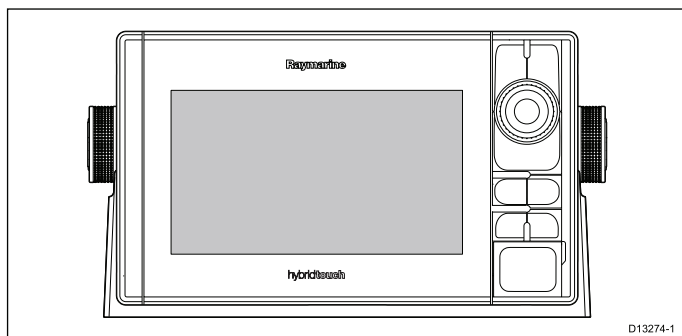

- MultiTouch capable LCD
- **Raymarine HybridTouch** controls
- **NMEA 0183**
- **NMEA 2000** via **SeaTalk^{ng}**
- **Bluetooth**
- **Wi-Fi**
- Internal GNSS (GPS / GLONASS) receiver
- Composite Video input
- **HDMI** video input (Not available on **eS7x** displays.)
- **GA150** GNSS Receiver antenna (Not available on **eS7x** displays.)

HybridTouch overview

If your multifunction display features HybridTouch, this enables you to operate the unit using the touchscreen and the physical buttons.

A HybridTouch display has physical buttons which can be used in addition to the touchscreen. Touchscreen only multifunction displays (which do not have physical buttons) can be connected to a remote keypad which allows HybridTouch functionality.

All functions can be accessed using the touchscreen. However, there may be situations (such as rough sea conditions) when it is not appropriate to use the touchscreen. In these situations, Raymarine strongly recommends that you activate the touch lock and use the physical buttons to operate your multifunction display.

Chapter 3: Planning the installation

Chapter contents

- 3.1 System integration on page 16
- 3.2 Installation checklist on page 22
- 3.3 Multiple data sources (MDS) overview on page 22
- 3.4 Identifying your display variant on page 23
- 3.5 Networking constraints on page 23
- 3.6 System protocols on page 24
- 3.7 Data master on page 25
- 3.8 Parts supplied — eS7x displays on page 26
- 3.9 Parts supplied — eS9x and eS12x displays on page 26
- 3.10 Tools required for installation on page 27
- 3.11 Selecting a location on page 27

3.1 System integration

Raymarine® multifunction displays (MFDs) are compatible with a wide range of marine electronics devices.

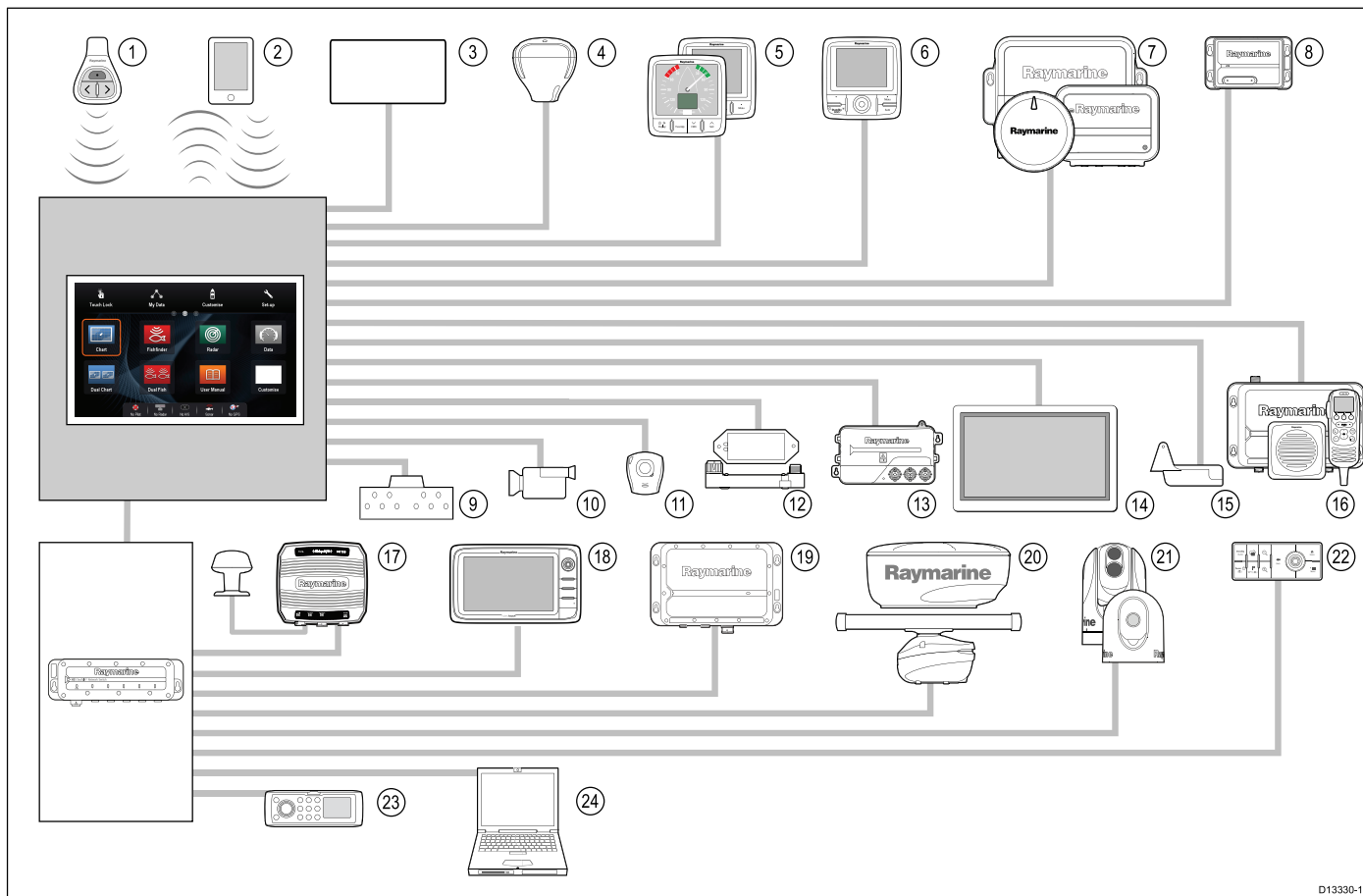

MFDs use various protocols to transfer data between devices in your system. The table below details which devices may be connected to your MFD, and the type of connections (in terms of protocols and physical interfaces):

Item	Device Type	Maximum quantity	Suitable Devices	Connections
1	Remote control	1 per MFD	Raymarine® RCU-3	Bluetooth
2	Mobile device (Smartphone / Tablet)	1 per multifunction display.	<p>For Raymarine® wireless video streaming and remote control apps:</p> <ul style="list-style-type: none"> • Apple iPhone 4 (or later) or iPad 2 (or later) • Android device with minimum 1GHz processor and running android 2.2.2 (or later) • Amazon Kindle Fire <p>For chartplotter sync with Navionics Marine app:</p> <ul style="list-style-type: none"> • Apple iPhone or iPad • Android-compatible smartphone or tablet <p>For media player control (Touchscreen MFDs only):</p> <ul style="list-style-type: none"> • Any Bluetooth-enabled device that supports Bluetooth 2.1+ EDR power class 1.5 (supported profile: AVRCP 1.0) 	<ul style="list-style-type: none"> • Chartplotter sync with Navionics Marine app: Wi-Fi • Video streaming and remote control: Wi-Fi • Media player control: Bluetooth 2.1+ EDR power class 1.5 (supported profile: AVRCP 1.0) or later

Item	Device Type	Maximum quantity	Suitable Devices	Connections
3	Vessel tank sensors — third-party	<ul style="list-style-type: none"> • Up to 5 x fuel. • 1 x fresh water. • 1 x waste water. • 1 x sewage. • 1 x bait / fish. 	Third-party NMEA 2000 interfaces	NMEA 2000 (via optional DeviceNet adaptor cables)
4	GNSS Receiver (external) — Raymarine®	1	Any combination of the following: <ul style="list-style-type: none"> • RS130 GPS • Raystar125 GPS • Raystar125+GPS (via optional SeaTalk to SeaTalkng® converter) 	SeaTalk , SeaTalkng® , or NMEA 0183
5	Instruments — Raymarine®	As determined by SeaTalkng® bus bandwidth and power loading.	SeaTalkng® : <ul style="list-style-type: none"> • i50 Depth, Speed, or Tridata • i60 Wind, CH Wind • i70 • ST70+ • ST70 SeaTalk (via optional SeaTalk to SeaTalkng® converter): <ul style="list-style-type: none"> • i40 Wind, Speed, Depth, or Bidata • ST60+ Wind, Speed, Depth, Rudder, or Compass • ST40 Wind, Speed, Depth, Rudder, or Compass 	SeaTalk , SeaTalkng®
6	Pilot control heads — Raymarine®	As determined by SeaTalk or SeaTalkng® bus bandwidth and power loading, as appropriate.	SeaTalkng® : <ul style="list-style-type: none"> • p70 • p70R • ST70 (SeaTalkng® course computer only.) • ST70+ (SeaTalkng® course computer only.) SeaTalk (via optional SeaTalk to SeaTalkng® converter): <ul style="list-style-type: none"> • ST6002 • ST7002 • ST8002 	SeaTalk , SeaTalkng®
7	Autopilots — Raymarine®	1	SeaTalkng® : <ul style="list-style-type: none"> • Evolution autopilots • All SPX course computers SeaTalk (via optional SeaTalk to SeaTalkng® converter): <ul style="list-style-type: none"> • ST1000 • ST2000 • S1000 • S1 	SeaTalk , SeaTalkng® , or NMEA 0183

Item	Device Type	Maximum quantity	Suitable Devices	Connections
			<ul style="list-style-type: none"> • S2 • S3 	
8	AIS — Raymarine®	1	<ul style="list-style-type: none"> • AIS350 • AIS650 • AIS950 	SeaTalk ^{ng} ®, or NMEA 0183
8	AIS — third-party	1	Third-party NMEA 0183-compatible AIS Class A or Class B receiver / transceiver	NMEA 0183
9	Vessel trim tabs — third-party	1 pair	Third-party NMEA 2000 interfaces	NMEA 2000 (via optional DeviceNet adaptor cables)
10	Analog video / camera	a6x / a7x = 0 a9x / a12x / e7 / e7D = 1 c Series = 1 e9x / e12x / e165 = 2 eS Series = 1 gS Series = 2	Composite PAL or NTSC video source	BNC connectors
10	IP camera	Multiple	<ul style="list-style-type: none"> • CAM200IP <div style="border: 1px solid black; padding: 5px; margin-top: 10px;"> <p>Note: Whilst third-party ONVIF compatible IP cameras may work, Raymarine® cannot guarantee their compatibility.</p> </div>	Via SeaTalk ^{hs} network
11	Lifetag (Man overboard alert)	1 basestation	All Raymarine® Lifetag basestations	SeaTalk (via optional SeaTalk to SeaTalk ^{ng} ® converter)
12	Engine interface — Raymarine®	1 unit for each engine CAN bus	<ul style="list-style-type: none"> • ECI-100 	SeaTalk ^{ng} ®
12	Engine interface — third-party	1	Third-party NMEA 2000 interfaces	NMEA 2000 (via optional DeviceNet adaptor cables)
13	Transducers and sensors — Raymarine®	1	Analog transducers: <ul style="list-style-type: none"> • Wind • Speed • Depth • Rudder reference • Fluxgate compass 	SeaTalk ^{ng} ® (via optional iTC-5 converter)
13	Transducers and sensors — Airmar	1	<ul style="list-style-type: none"> • DT800 Smart Sensor • DST800 Smart Sensor • PB200 weather station 	SeaTalk ^{ng} ® (via optional iTC-5 converter)
14	External display	a6x / a7x = 0 a9x / a12x = 1 c Series = 0 e7 / e7D = 0 e9x / e12x / e165 = 1 eS7x = 0 eS9x / eS12x = 1 gS Series = 1	e.g. HDTV	a9x / a12x = 15 pin D-Type connector (VGA Style) e9x / e12x / e165 = 15 pin D-Type connector (VGA Style) eS9x / eS12x = HDMI gS Series = HDMI

Item	Device Type	Maximum quantity	Suitable Devices	Connections
15	Sonar transducer	1	<ul style="list-style-type: none"> • P48 • P58 • P74 • B60 20° • B60 12° • B744V ; OR: <ul style="list-style-type: none"> • Any 600 watt / 1Kw compatible transducer (via optional E66066 adaptor cable) ; OR: <ul style="list-style-type: none"> • Any Minn Kota transducer (via optional A62363 adaptor cable) Connection via external Raymarine® Sonar Module: <ul style="list-style-type: none"> • Any sonar module-compatible transducer 	Direct connection to 600 W internal sonar variant displays.
15	DownVision™ transducers	1	Direct connection to internal CHIRP DownVision™ variant displays <ul style="list-style-type: none"> • CPT-100 — Transom mount • CPT-110 — Thru-hull plastic • CPT-120 — Thru-hull bronze 	Direct connection to CHIRP DownVision™ variant displays.
16	DSC VHF radio — Raymarine®	1	SeaTalk^{ng}® : <ul style="list-style-type: none"> • Ray50 • Ray60 • Ray70 • Ray260 • Ray260 AIS NMEA 0183 : <ul style="list-style-type: none"> • Ray50 • Ray60 • Ray70 • Ray49 • Ray55 • Ray218 • Ray240 	NMEA 0183 or SeaTalk^{ng}®
17	Raymarine® Sirius marine weather / satellite radio receiver (North America only)	1	SeaTalk^{hs} : <ul style="list-style-type: none"> • SR150 • SR100 • SR6 SeaTalk^{ng}® : <ul style="list-style-type: none"> • SR50 	SeaTalk^{hs} , SeaTalk^{ng}®

Item	Device Type	Maximum quantity	Suitable Devices	Connections
18	Additional multifunction display(s) — Raymarine®	9	<p>3rd generation Raymarine® multifunction displays SeaTalk^{hs} (recommended):</p> <ul style="list-style-type: none"> • a Series • c Series • e Series • gS Series • eS Series <div style="border: 1px solid black; padding: 5px; margin-top: 10px;"> <p>Note: You can connect Raymarine® multifunction displays using NMEA 0183 or SeaTalk^{ng}® but not all functions are supported.</p> </div> <div style="border: 1px solid black; padding: 5px; margin-top: 10px;"> <p>Note: Visit www.raymarine.com to download the latest software version for your display.</p> </div>	SeaTalk^{hs}
18	Additional multifunction display(s) — third-party	<ul style="list-style-type: none"> • Connections to multifunction display NMEA outputs: 4 • Connections to multifunction display NMEA inputs: 2 	NMEA 0183 –compatible chartplotters and multifunction displays	NMEA 0183
19	Sonar Modules (Fishfinder) — Raymarine®	Multiple	<ul style="list-style-type: none"> • CP100 — DownVision™ • CP200 — SideVision™ • CP300 / CP370— Traditional sonar • CP450C / CP470 — CHIRP sonar • CP570 CHIRP professional sonar • 600 W Sonar and CHIRP DownVision™ variant displays. 	SeaTalk^{hs}
20	Radar — Raymarine®	2	<p>All Raymarine® Non-HD Digital Radomes and HD or SuperHD radar scanners.</p> <div style="border: 1px solid black; padding: 5px; margin-top: 10px;"> <p>Note: Please ensure your radar scanner is using the latest software version.</p> </div>	SeaTalk^{hs}
21	Thermal camera — Raymarine®	1	<ul style="list-style-type: none"> • T200 Series • T300 Series • T400 Series • T800 Series • T900 Series 	SeaTalk^{hs} (for control), BNC connector (for video)
22	Remote keypad	Multiple	<ul style="list-style-type: none"> • RMK-9 	SeaTalk^{hs}

Item	Device Type	Maximum quantity	Suitable Devices	Connections
23	Fusion entertainment systems	Multiple	Fusion 700 series entertainment systems: <ul style="list-style-type: none"> • MS-IP700 • MS-AV700 	SeaTalk^{hs}
24	PC / laptop	1	Windows-compatible PC or laptop running Raymarine[®] Voyage Planner software.	SeaTalk^{hs}

Note: Raymarine[®] cannot guarantee the compatibility of any third-party devices listed above.

3.2 Installation checklist

Installation includes the following activities:

Installation Task	
1	Plan your system.
2	Obtain all required equipment and tools.
3	Site all equipment.
4	Route all cables.
5	Drill cable and mounting holes.
6	Make all connections into equipment.
7	Secure all equipment in place.
8	Power on and test the system.

3.3 Multiple data sources (MDS) overview

Installations that include multiple instances of data sources can cause data conflicts. An example is an installation featuring more than one source of GPS data.

MDS enables you to manage conflicts involving the following types of data:

- GPS Position.
- Heading.
- Depth.
- Speed.
- Wind.

Typically this exercise is completed as part of the initial installation, or when new equipment is added.

If this exercise is NOT completed the system will automatically attempt to resolve data conflicts. However, this may result in the system choosing a source of data that you do not want to use.

If MDS is available the system can list the available data sources and allow you to select your preferred data source. For MDS to be available all products in the system that use the data sources listed above must be MDS-compliant. The system can list any products that are NOT compliant. It may be necessary to upgrade the software for these non-compliant products to make them compliant. Visit the Raymarine website (www.raymarine.com) to obtain the latest software for your products. If MDS-compliant software is not available and you do NOT want the system to automatically attempt to resolve data conflicts, any non-compliant product(s) can be removed or replaced to ensure the entire system is MDS-compliant.

3.4 Identifying your display variant

To discover which model display you have follow the steps below:

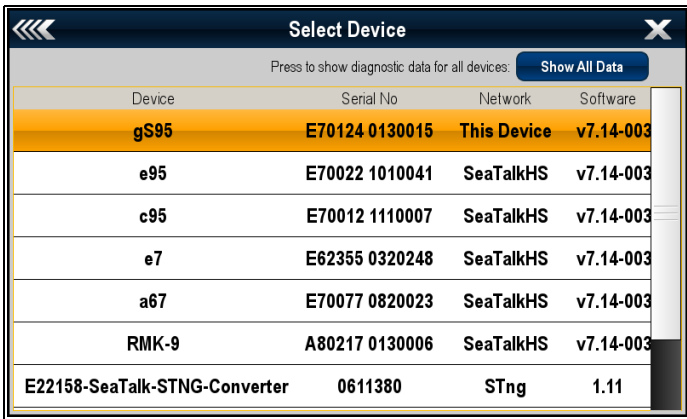

The screenshot shows a 'Select Device' screen with a table of networked displays. The table has four columns: Device, Serial No, Network, and Software. The first row is highlighted in orange and shows 'gS95' with serial number 'E70124 0130015', network 'This Device', and software 'v7.14-003'. Other rows include 'e95', 'c95', 'e7', 'a67', 'RMK-9', and 'E22158-SeaTalk-STNG-Converter'.

Device	Serial No	Network	Software
gS95	E70124 0130015	This Device	v7.14-003
e95	E70022 1010041	SeaTalkHS	v7.14-003
c95	E70012 1110007	SeaTalkHS	v7.14-003
e7	E62355 0320248	SeaTalkHS	v7.14-003
a67	E70077 0820023	SeaTalkHS	v7.14-003
RMK-9	A80217 0130006	SeaTalkHS	v7.14-003
E22158-SeaTalk-STNG-Converter	0611380	STng	1.11

From the homescreen:

1. Select **Set-up**.
2. Select **Maintenance**.
3. Select **Diagnostics**.
4. Select **Select Device**.
5. Search the Network column for the **'This Device'** entry.
6. The Device column for this record will list the model of your display.

3.5 Networking constraints

Up to 10 **LightHouse** powered **MFDs** can be connected together using **SeaTalk^{hs}**. It is recommended that all networked displays contain the same software version.

Software versions

- All networked **aa Series**, **c Series** and **e Series** displays must contain **LightHouse** software release V4.32 or later.
- All networked **gS Series** displays must contain **LightHouse** software release V7.43 or later.
- All networked **eS Series** displays must contain **LightHouse** software release V14.xx or later.

Master / repeater operation

- Any network featuring more than 1 **MFD** must have 1 of the displays designated as the Data Master.
- The Data Master display will receive data through **NMEA 0183** and / or **SeaTalk^{ng}**, and bridge the data over **SeaTalk^{hs}** to other networked displays.

Homescreen sharing

- When networked, **MFDs** can share the Data Master's Homescreen.

Cartography sharing

- The cartography contained on chart cards is always used in preference to embedded world base maps.
- Chart card cartography can be shared between networked **MFDs**.

Radar operation

- **MFDs** support the use of up to 2 Radar scanners simultaneously.
- The data supplied by a connected Radar scanner(s) is repeated to networked displays.

Note: All **MFDs** must have **LightHouse II** Release V12.26 software or later to enable multiple radar support.

Sonar / DownVision™ / SideVision™ operation

- You can connect an external sonar modules to the **MFD** via the **SeaTalk^{hs}** network.
- 600 W sonar and **CHIRP DownVision™** variant displays include an internal sonar module which enables direct connection of a compatible transducer.
- You can have multiple active sonar modules (internal and external) on a network.
- The data supplied by the sonar module is repeated to networked displays.

Note:

- All **MFDs** must have **LightHouse II** Release V10.41 software or later to enable multiple sonar support.
- Sonar modules should be updated to the latest available software version to ensure compatibility.

3.6 System protocols

Your Multifunction Display can connect to various instruments and displays to share information and so improve the functionality of the system. These connections may be made using a number of different protocols. Fast and accurate data collection and transfer is achieved by using a combination of the following data protocols:

- SeaTalk^{hs}
- SeaTalk^{ng}
- NMEA 2000
- SeaTalk
- NMEA 0183

Incompatible displays

If you connect a multifunction display to your system that is not compatible, a warning message will be displayed until you disconnect the incompatible device from your network.

Your **MFD** is not compatible with the following Raymarine displays:

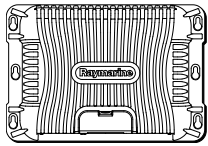
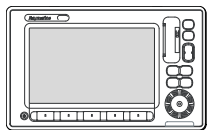
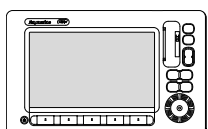
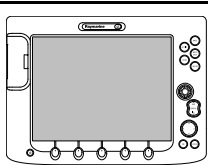
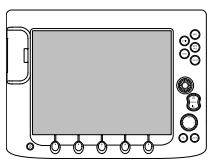
Product Image	Multifunction display	Generation
	G-Series	2 nd generation
	E-Series Widescreen	2 nd generation
	C-Series Widescreen	2 nd generation
	E-Series Classic	1 st generation
	C-Series Classic	1 st generation

Note: You may find that your system does not use all of the connection types or instrumentation described in this section.

SeaTalk^{hs}

SeaTalk^{hs} is an ethernet based marine network. This high speed protocol allows compatible equipment to communicate rapidly and share large amounts of data.

Information shared using the SeaTalk^{hs} network includes:

- Shared cartography (between compatible displays).
- Digital radar data.
- Sonar data.

Seataalk^{ng}

SeaTalk^{ng} (Next Generation) is an enhanced protocol for connection of compatible marine instruments and equipment. It replaces the older SeaTalk and SeaTalk² protocols.

SeaTalk^{ng} utilizes a single backbone to which compatible instruments connect using a spur. Data and power are carried within the backbone. Devices that have a low draw can be powered from the network, although high current equipment will need to have a separate power connection.

SeaTalk^{ng} is a proprietary extension to NMEA 2000 and the proven CAN bus technology. Compatible NMEA 2000 and SeaTalk / SeaTalk² devices can also be connected using the appropriate interfaces or adaptor cables as required.

NMEA 2000

NMEA 2000 offers significant improvements over NMEA 0183, most notably in speed and connectivity. Up to 50 units can simultaneously transmit and receive on a single physical bus at any one time, with each node being physically addressable. The standard was specifically intended to allow for

a whole network of marine electronics from any manufacturer to communicate on a common bus via standardized message types and formats.

SeaTalk

SeaTalk is a protocol which enables compatible instruments to connect to each other and share data.

The SeaTalk cable system is used to connect compatible instruments and equipment. The cable carries power and data and enables connection without the need for a central processor.

Additional instruments and functions can be added to a SeaTalk system, simply by plugging them into the network. SeaTalk equipment can also communicate with other non-SeaTalk equipment via the NMEA 0183 standard, provided a suitable interface is used.

NMEA 0183

The NMEA 0183 Data Interface Standard was developed by the National Marine Electronics Association of America. It is an international standard to enable equipment from many different manufacturers to be connected together and share information.

The NMEA 0183 standard carries similar information to SeaTalk. However it has the important difference that one cable will only carry information in one direction. For this reason NMEA 0183 is generally used to connect a data receiver and a transmitter together, e.g. a compass sensor transmitting heading to a radar display. This information is passed in 'sentences', each of which has a three letter sentence identifier. It is therefore important when checking compatibility between items that the same sentence identifiers are used some examples of which are:

- VTG - carries Course and Speed Over Ground data.
- GLL - carries latitude and longitude.
- DBT - carries water depth.
- MWV - carries relative wind angle and wind speed data.

NMEA Baud rates

The NMEA 0183 standard operates at a number of different speeds, depending upon the particular requirement or equipment capabilities. Typical examples are:

- 4800 baud rate. Used for general purpose communications, including FastHeading data.
- 38400 baud rate. Used for AIS and other high speed applications.

3.7 Data master

Any system containing more than one networked multifunction display must have a designated data master.

The data master is the display which serves as a primary source of data for all displays, it also handles all external sources of information. For example the displays may require heading information from the autopilot and GPS systems, usually received through a SeaTalk^{ng} or NMEA connection. The data master is the display to which the SeaTalk, NMEA and any other data connections are made, it then bridges the data to the SeaTalk^{hs} network and any compatible repeat displays. Information shared by the data master includes:

- Cartography
- Routes and waypoints
- Radar
- Sonar
- Data received from the autopilot, instruments, the engine and other external sources.

Your system may be wired for redundancy with data connections made to repeat displays. However these connections will only become active in the event of a fault and/or reassignment of the data master.

In an autopilot system which does not contain a dedicated pilot control head the Data master also acts as the control for the autopilot.

3.8 Parts supplied — eS7x displays

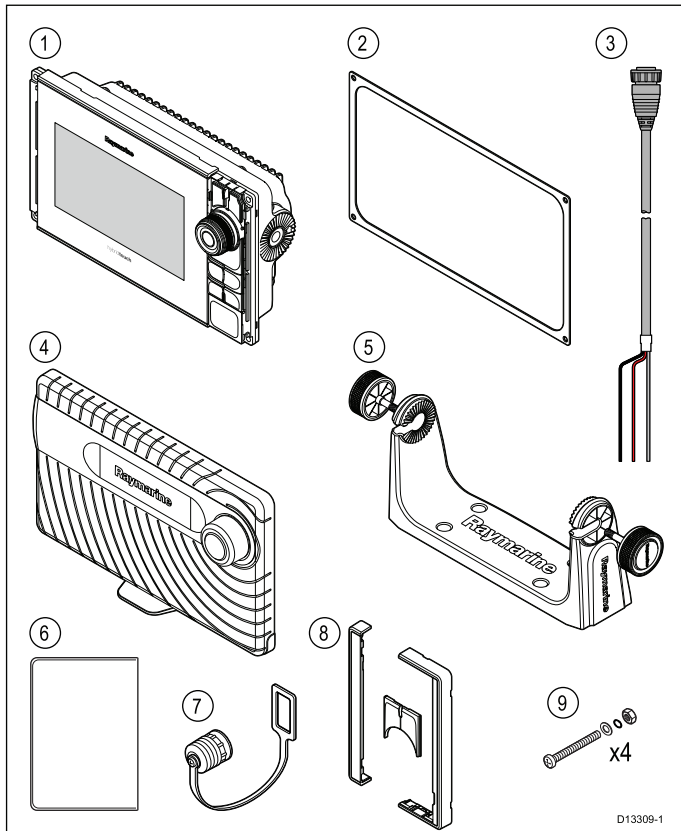

D13309-1

Item	Description	Quantity
1	Multifunction display	1
2	Panel seal gasket	1
3	1.5 m (4.9 ft) Power cable	1
4	Sun cover	1
5	Trunion bracket and knobs	1
6	Document pack	1
7	Power cable protective cap	1
8	Bezel pieces and Home/Menu button	1
9	Fixing sets	4

3.9 Parts supplied — eS9x and eS12x displays

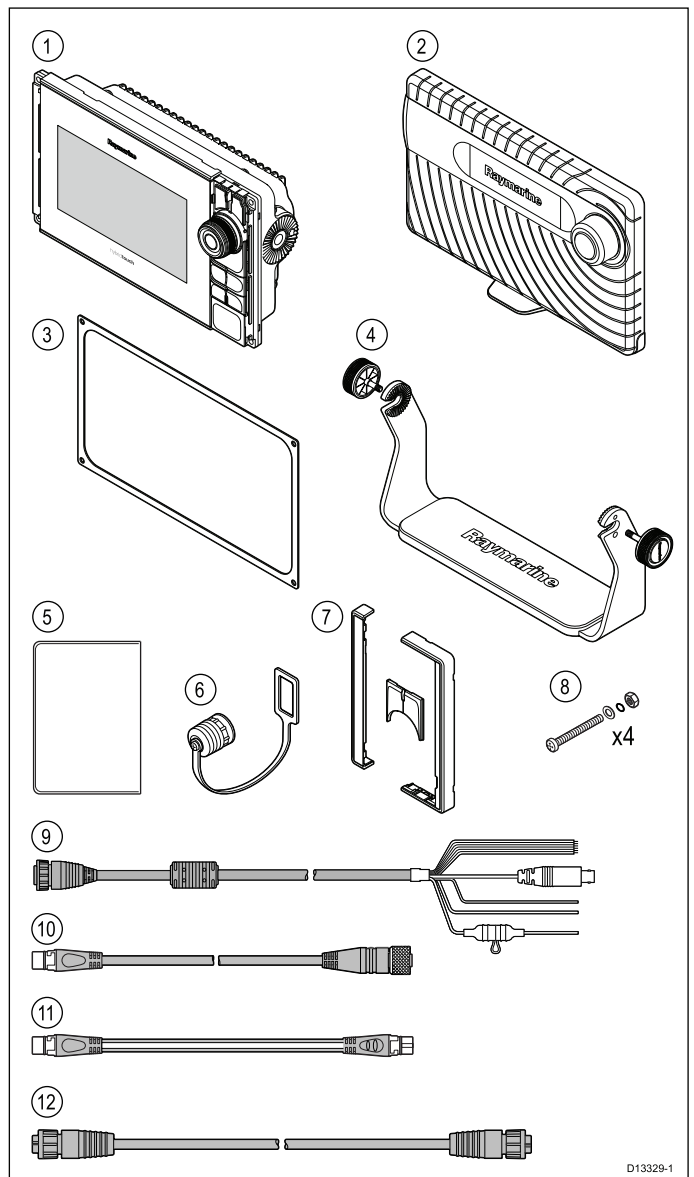

D13329-1

Item	Description	Quantity
1	Multifunction display	1
2	Sun cover	1
3	Panel seal gasket	1
4	Trunion bracket and knobs	1
5	Document pack	1
6	Power cable protective cap	1
7	Bezel pieces and Home/Menu button	1
8	Fixing sets	1
9	1.5 m (4.9 ft) Power and data cable (Power/NMEA/Video)	4
10	SeaTalk^{ng} to DeviceNet adaptor cable	1
11	1 m (3.3 ft.) SeaTalk^{ng} spur cable	1
12	2 m (6.6 ft.) RayNet cable	1

3.10 Tools required for installation

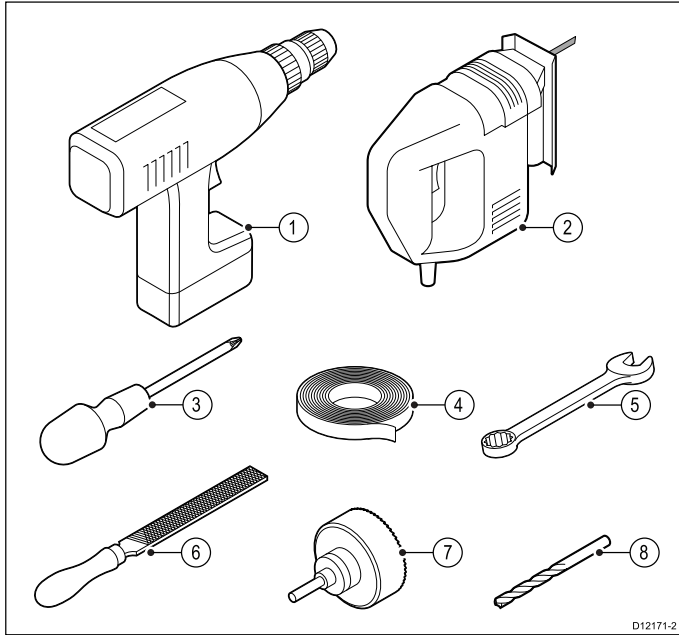

1. Power drill.
2. Jigsaw.
3. Pozidrive screwdriver.
4. Adhesive tape.
5. Spanner for surface mounting or bracket mounting fixings.
6. File.
7. Hole saw for flush mounting (For hole saw size refer to your product's mounting template).
8. Drill bit for surface mounting or bracket mounting.

3.11 Selecting a location



Warning: Potential ignition source

This product is NOT approved for use in hazardous/flammable atmospheres. Do NOT install in a hazardous/flammable atmosphere (such as in an engine room or near fuel tanks).

General location requirements

When selecting a location for your product it is important to consider a number of factors.

Key factors which can affect product performance are:

- **Ventilation**

To ensure adequate airflow:

- Ensure that product is mounted in a compartment of suitable size.
- Ensure that ventilation holes are not obstructed. Allow adequate separation of all equipment.

Any specific requirements for each system component are provided later in this chapter.

- **Mounting surface**

Ensure product is adequately supported on a secure surface. Do not mount units or cut holes in places which may damage the structure of the vessel.

- **Cabling**

Ensure the product is mounted in a location which allows proper routing, support and connection of cables:

- Minimum bend radius of 100 mm (3.94 in) unless otherwise stated.
- Use cable clips to prevent stress on connectors.
- If your installation requires multiple ferrites to be added to a cable then additional cable clips should be used to ensure the extra weight of the cable is supported.

- **Water ingress**

The product is suitable for mounting both above and below decks. Although the unit is waterproof, it is good practice to locate it in a protected area away from prolonged and direct exposure to rain and salt spray.

- **Electrical interference**

Select a location that is far enough away from devices that may cause interference, such as motors, generators and radio transmitters / receivers.

- **Power supply**

Select a location that is as close as possible to the vessel's DC power source. This will help to keep cable runs to a minimum.

Compass safe distance

To prevent potential interference with the vessel's magnetic compasses, ensure an adequate distance is maintained from the display.

When choosing a suitable location for the multifunction display you should aim to maintain the maximum possible distance between the display and any compasses. Typically this distance should be at least 1 m (3 ft) in all directions. However for some smaller vessels it may not be possible to locate the display this far away from a compass. In this situation, the following figures provide the minimum safe distance that should be maintained between the display and any compasses.

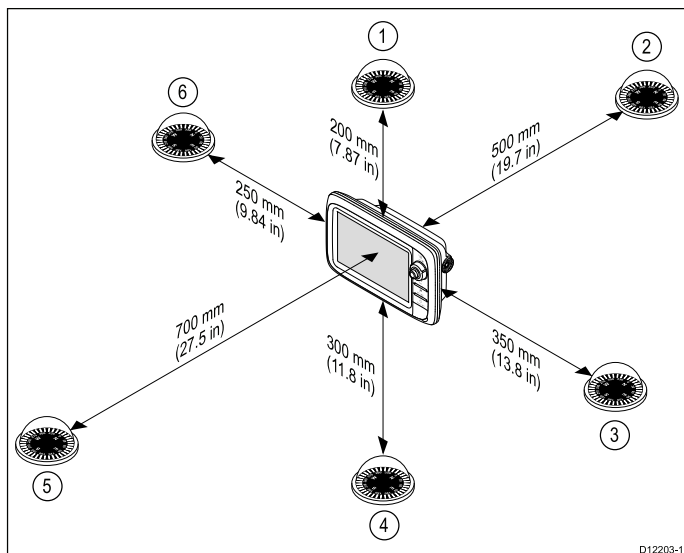

Item	Compass position in relation to display	Minimum safe distance from display
1	Top	200 mm (7.87 in.)
2	Rear	500 mm (19.7 in.)
3	Right-hand side	350 mm (13.8 in.)
4	Underside	300 mm (11.8 in.)
5	Front	700 mm (27.5 in.)
6	Left-hand side	250 mm (9.84 in.)

GPS location requirements

In addition to general guidelines concerning the location of marine electronics, there are a number of environmental factors to consider when installing equipment with an internal GPS antenna.

Mounting location

- **Above Decks mounting:**
Provides optimal GPS performance. (For equipment with appropriate waterproof rating.)
- **Below Decks mounting:**
GPS performance may be less effective and may require an external GPS antenna mounted above decks.

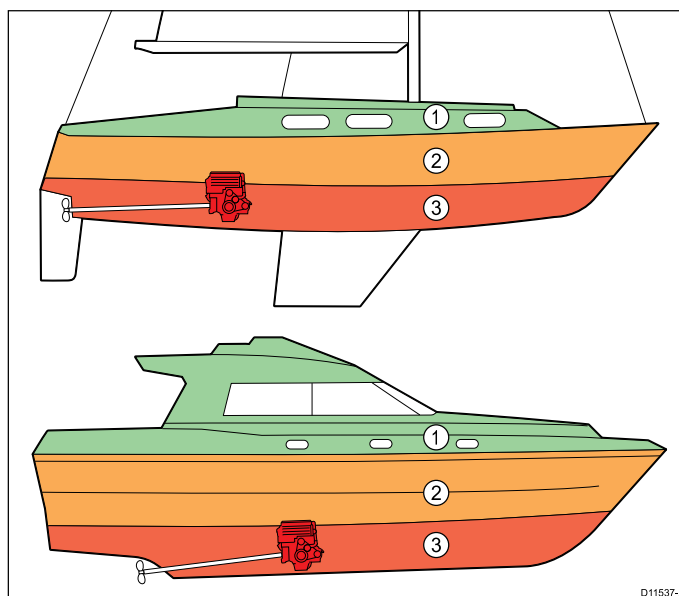

1.		This location provides optimal GPS performance (above decks).
2.		In this location, GPS performance may be less effective.
3.		This location is NOT recommended for GPS antenna.

Vessel construction

The construction of your vessel can have an impact on GPS performance. For example, the proximity of heavy structure such as a structural bulkhead, or the interior of larger vessels may result in a reduced GPS signal. Before locating equipment with an internal GPS antenna below decks, seek professional assistance and consider use of an external GPS antenna mounted above decks.

Prevailing conditions

The weather and location of the vessel can affect the GPS performance. Typically calm clear conditions provide for a more accurate GPS fix. Vessels at extreme northerly or southerly latitudes may also receive a weaker GPS signal. GPS antenna mounted below decks will be more susceptible to performance issues related to the prevailing conditions.

EMC installation guidelines

Raymarine equipment and accessories conform to the appropriate Electromagnetic Compatibility (EMC) regulations, to minimize electromagnetic interference between equipment and minimize the effect such interference could have on the performance of your system

Correct installation is required to ensure that EMC performance is not compromised.

Note: In areas of extreme EMC interference, some slight interference may be noticed on the product. Where this occurs the product and the source of the interference should be separated by a greater distance.

For **optimum** EMC performance we recommend that wherever possible:

- Raymarine equipment and cables connected to it are:
 - At least 1 m (3 ft) from any equipment transmitting or cables carrying radio signals e.g. VHF radios, cables and antennas. In the case of SSB radios, the distance should be increased to 7 ft (2 m).
 - More than 2 m (7 ft) from the path of a radar beam. A radar beam can normally be assumed to spread 20 degrees above and below the radiating element.
- The product is supplied from a separate battery from that used for engine start. This is important to prevent erratic behavior and data loss which can occur if the engine start does not have a separate battery.
- Raymarine specified cables are used.
- Cables are not cut or extended, unless doing so is detailed in the installation manual.

Note: Where constraints on the installation prevent any of the above recommendations, always ensure the maximum possible separation between different items of electrical equipment, to provide the best conditions for EMC performance throughout the installation

Viewing angle considerations

As display contrast, color and night mode performance are all affected by the viewing angle, Raymarine recommends you temporarily power up the display when planning the installation, to enable you to best judge which location gives the optimum viewing angle.

Viewing angles - eS Series

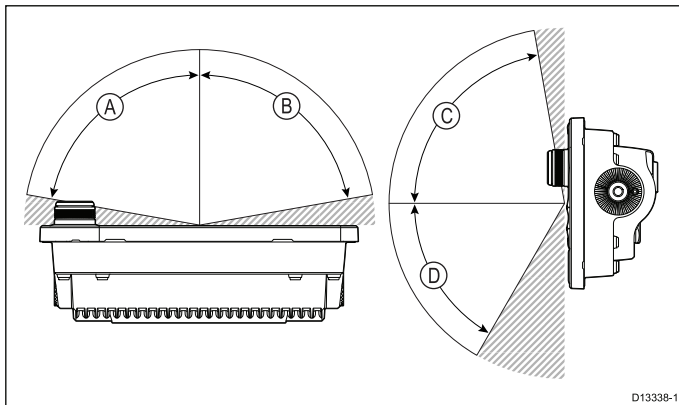

	eS7x	eS9x	eS12x
A	70°	80°	80°
B	70°	80°	80°
C	60°	80°	80°
D	70°	80°	80°

Note: The viewing angles stated were taken using internationally agreed standards and should be used for comparison purposes only. Do NOT install the product before testing its viewability in the desired location.

Product dimensions

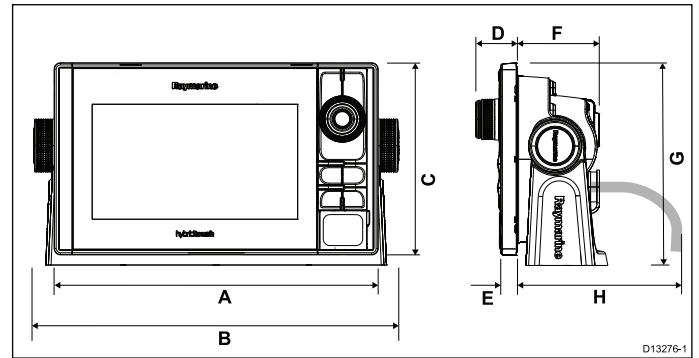

	eS7x	eS9x	eS12x
A	244.2 mm (9.6 in.)	299.3 mm (11.8 in.)	358 mm (14 in.)
B	275.2 mm (10.8 in.)	332 mm (13 in.)	390.5 mm (15.4 in.)
C	144.7 mm (5.7 in.)	173.8 mm (6.8 in.)	222.8 mm (8.8 in.)
D	31 mm (1.2 in.)	32 mm (1.3 in.)	31.9 mm (1.3 in.)
E	12.5 mm (0.49 in.)	13.5 mm (0.53 in.)	13.5 mm (0.53 in.)
F	61.9 mm (2.4 in.)	64.7 mm (2.6 in.)	64.4 mm (2.5 in.)
G	152.5 mm (6 in.)	184.6 mm (7.3 in.)	244.5 mm (9.6 in.)
H	150 mm (5.9 in.)	150 mm (5.9 in.)	150 mm (5.9 in.)

Chapter 4: Cables and connections

Chapter contents

- 4.1 General cabling guidance on page 32
- 4.2 Connections overview on page 33
- 4.3 3-pin power connection on page 34
- 4.4 Power and data (combined) connection on page 34
- 4.5 **SeaTalk^{ng}**® connections on page 36
- 4.6 NMEA 2000 connection on page 37
- 4.7 **SeaTalk** connection on page 38
- 4.8 NMEA 0183 connection — Power/NMEA/Video cable on page 38
- 4.9 Sonar module and transducer connection on page 40
- 4.10 Radar network connection on page 41
- 4.11 GA150 connection on page 44
- 4.12 GNSS / GPS connection on page 44
- 4.13 AIS connection on page 45
- 4.14 Fastheading connection on page 45
- 4.15 Keypad network connection on page 46
- 4.16 Weather receiver connection on page 46
- 4.17 HDMI video output on page 47
- 4.18 Video connection — composite on page 47
- 4.19 IP Camera connection on page 48
- 4.20 Thermal camera connection on page 49
- 4.21 Fusion network connection on page 50
- 4.22 Fusion **NMEA 2000** connection on page 51
- 4.23 Media player connection on page 51
- 4.24 Raymarine mobile app connection on page 52
- 4.25 Bluetooth remote control connection on page 53

4.1 General cabling guidance

Suppression ferrites

Raymarine cables may be fitted with suppression ferrites. These are important for correct EMC performance. If a ferrite has to be removed for any purpose (e.g. installation or maintenance), it must be replaced in the original position before the product is used.

Use only ferrites of the correct type, supplied by Raymarine authorized dealers.

Where an installation requires multiple ferrites to be added to a cable, additional cable clips should be used to prevent stress on the connectors due to the extra weight of the cable.

Connections to other equipment

Requirement for ferrites on non-Raymarine cables

If your Raymarine equipment is to be connected to other equipment using a cable not supplied by Raymarine, a suppression ferrite **MUST** always be attached to the cable near the Raymarine unit.

Cable types and length

It is important to use cables of the appropriate type and length

- Unless otherwise stated use only standard cables of the correct type, supplied by Raymarine.
- Ensure that any non-Raymarine cables are of the correct quality and gauge. For example, longer power cable runs may require larger wire gauges to minimize voltage drop along the run.

Routing cables

Cables must be routed correctly, to maximize performance and prolong cable life.

- Do NOT bend cables excessively. Wherever possible, ensure a minimum bend diameter of 200 mm (8 in) / minimum bend radius of 100 mm (4 in).

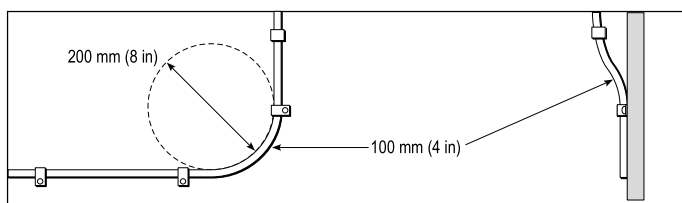

- Protect all cables from physical damage and exposure to heat. Use trunking or conduit where possible. Do NOT run cables through bilges or doorways, or close to moving or hot objects.
- Secure cables in place using tie-wraps or lacing twine. Coil any extra cable and tie it out of the way.
- Where a cable passes through an exposed bulkhead or deckhead, use a suitable watertight feed-through.
- Do NOT run cables near to engines or fluorescent lights.

Always route data cables as far away as possible from:

- other equipment and cables,
- high current carrying ac and dc power lines,
- antennae.

Strain relief

Ensure adequate strain relief is provided. Protect connectors from strain and ensure they will not pull out under extreme sea conditions.

Circuit isolation

Appropriate circuit isolation is required for installations using both AC and DC current:

- Always use isolating transformers or a separate power-inverter to run PC's, processors, displays and other sensitive electronic instruments or devices.
- Always use an isolating transformer with Weather FAX audio cables.
- Always use an isolated power supply when using a 3rd party audio amplifier.
- Always use an RS232/NMEA converter with optical isolation on the signal lines.
- Always make sure that PC's or other sensitive electronic devices have a dedicated power circuit.

Cable shielding

Ensure that all data cables are properly shielded that the cable shielding is intact (e.g. hasn't been scraped off by being squeezed through a tight area).

Network cable connector types

There are 2 types of network cable connector — SeaTalk^{hs} and RayNet.

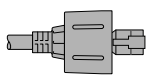
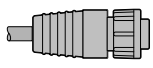
	SeaTalk^{hs} connector — used for connecting SeaTalk ^{hs} devices to a Raymarine network switch via SeaTalk ^{hs} cables.
	RayNet connector — used for connecting Raymarine network switches and SeaTalk ^{hs} devices to the multifunction display via RayNet cables. Also required for connecting a crossover coupler if only one device is being connected to the display's Network connector.

4.2 Connections overview

Details of the connections available on Raymarine multifunction displays are shown below.

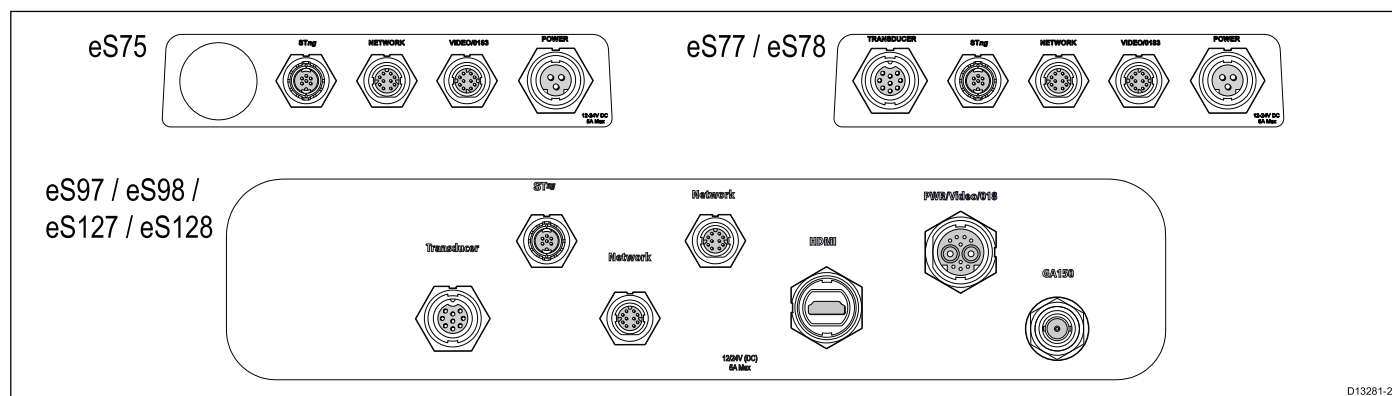

	600 W transducer	Down-Vision transducer	NMEA 2000 / SeaTalkng	SeaTalk ^{hs} / RayNet		HDMI output	External antenna	Power / NMEA / Video		
				Network 1	Network 2			NMEA 0183 / Video in	Power	Power / NMEA / Video
eS75	✗	✗	✓	✓	✗	✗	✗	✓	✓	✗
eS77	✓	✗	✓	✓	✗	✗	✗	✓	✓	✗
eS78	✗	✓	✓	✓	✗	✗	✗	✓	✓	✗
eS97	✓	✗	✓	✓	✓	✓	✓	✗	✗	✓
eS98	✗	✓	✓	✓	✓	✓	✓	✗	✗	✓
eS127	✓	✗	✓	✓	✓	✓	✓	✗	✗	✓
eS128	✗	✓	✓	✓	✓	✓	✓	✗	✗	✓

Connector and cable protective caps

Unused connectors and disconnected cables should be adequately protected against damage.

Important:

The rear connectors on your product are fitted with protective caps which should be securely fitted over any connectors that are not going to be used / connected.

If any cables are to be left disconnected then, if available use the cables protective cap or insulation tape to protect the cable connector.

4.3 3-pin power connection

The details below apply to **MFDs** that have a 3-pin power cable.

Refer to the *Connections Overview* section to establish the power connection for your **MFD**.

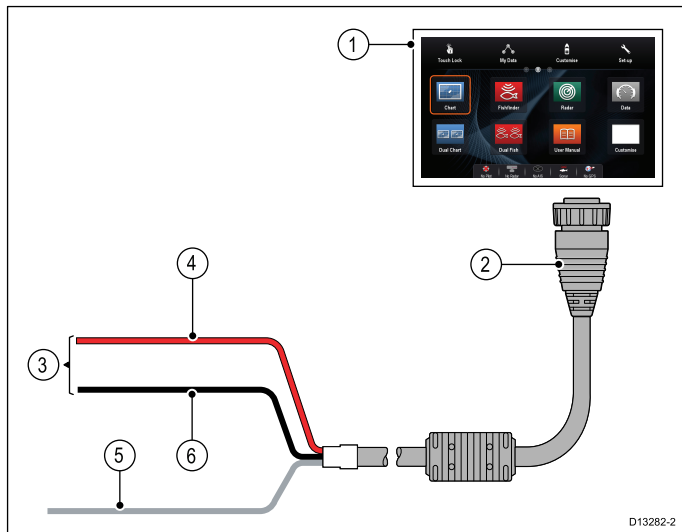

1. **MFD**
2. 3-pin power cable
3. Connection to power supply
4. Red cable (positive)
5. Ground (drain) wire
6. Black cable (negative)

In-line fuse and thermal breaker ratings

The following in-line fuse and thermal breaker ratings apply to your product:

In-line fuse rating	Thermal breaker rating
5 A	3 A (if only connecting one device)

Note:

- The suitable fuse rating for the thermal breaker is dependent on the number of devices you are connecting. If in doubt consult an authorized Raymarine dealer.
- Your product's power cable may have a fitted in-line fuse, if not then you must add an in-line fuse / breaker to the positive wire of your products power connection.

4.4 Power and data (combined) connection

The details below apply to **MFDs** that have a combined power/NMEA/video cable.

Refer to the *Connections Overview* section to establish the power connection for your **MFD**.

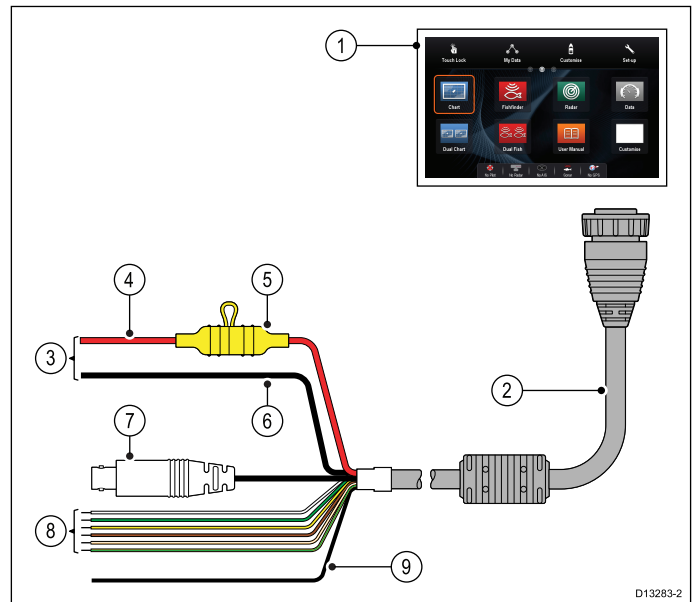

1. **MFD**
2. Combined Power and data cable
3. Connection to vessel's 12 V / 24 V dc power supply
4. Red cable (positive)
5. Fuse
6. Black cable (negative)
7. Video input cable
8. NMEA 0183 data cables
9. Ground (drain) wire

In-line fuse and thermal breaker ratings

The following in-line fuse and thermal breaker ratings apply to your product:

In-line fuse rating	Thermal breaker rating
15 A	15 A (if only connecting one device)

Note:

- The suitable fuse rating for the thermal breaker is dependent on the number of devices you are connecting. If in doubt consult an authorized Raymarine dealer.
- Your product's power cable may have a fitted in-line fuse, if not then you must add an in-line fuse / breaker to the positive wire of your products power connection.

Power distribution

Recommendations and best practice.

- The product is supplied with a power cable. Only use the power cable supplied with the product. Do

NOT use a power cable designed for, or supplied with, a different product.

- Refer to the *Power connection* section for more information on how to identify the wires in your product's power cable, and where to connect them.
- See below for more information on implementation for some common power distribution scenarios.

Important: When planning and wiring, take into consideration other products in your system, some of which (e.g. sonar modules) may place large power demand peaks on the vessel's electrical system.

Note: The information provided below is for guidance only, to help protect your product. It covers common vessel power arrangements, but does NOT cover every scenario. If you are unsure how to provide the correct level of protection, please consult an authorized Raymarine dealer or a suitably qualified professional marine electrician.

Implementation — direct connection to battery

- The power cable supplied with your product may be connected directly to the vessel's battery, via a suitably rated fuse or breaker.
- The power cable supplied with your product may NOT include a separate drain wire. If this is the case, only the power cable's red and black wires need to be connected.
- If the supplied power cable is NOT fitted with an inline fuse, you MUST fit a suitably rated fuse or breaker between the red wire and the battery's positive terminal.
- Refer to the inline fuse ratings provided in the product's documentation.
- If you need to extend the length of the power cable supplied with your product, ensure you observe the dedicated *Power cable extensions* advice provided in the product's documentation.

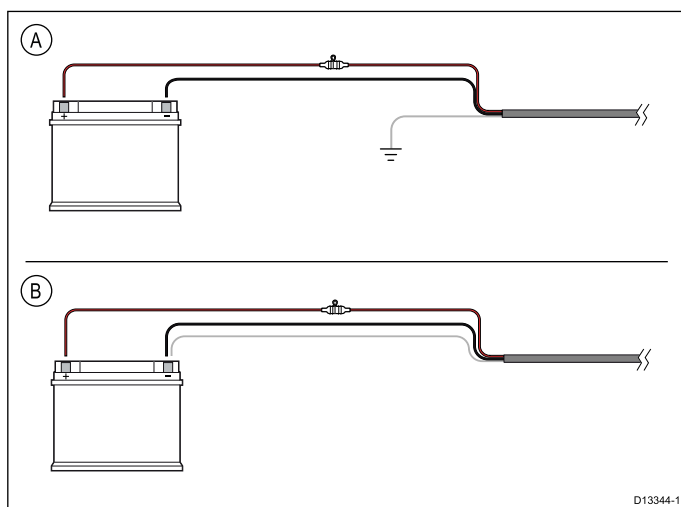

A	Battery connection scenario A: suitable for a vessel with a common RF ground point. In this scenario, if your product's power cable is supplied with a separate drain wire then it should be connected to the vessel's common ground point.
B	Battery connection scenario B: suitable for a vessel without a common grounding point. In this case, if your product's power cable is supplied with a separate drain wire then it should be connected directly to the battery's negative terminal.

Implementation — connection to distribution panel

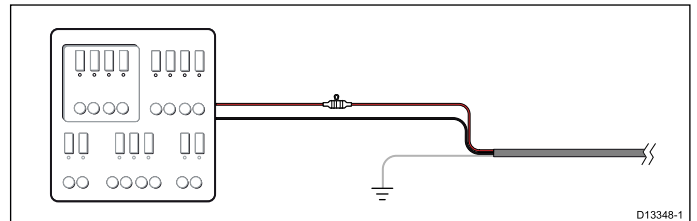

- Alternatively, the supplied power cable may be connected to a suitable breaker or switch on the vessel's distribution panel or factory-fitted power distribution point.
- The distribution point should be fed from the vessel's primary power source by 8 AWG (8.36 mm²) cable.
- Ideally, all equipment should be wired to individual suitably-rated thermal breakers or fuses, with appropriate circuit protection. Where this is not possible and more than 1 item of equipment shares a breaker, use individual in-line fuses for each power circuit to provide the necessary protection.
- In all cases, observe the recommended breaker / fuse ratings provided in the product's documentation.
- If you need to extend the length of the power cable supplied with your product, ensure you observe the dedicated *Power cable extensions* advice provided in the product's documentation.

Important: Be aware that the suitable fuse rating for the thermal breaker or fuse is dependent on the number of devices you are connecting.

Grounding

Ensure that you observe the separate grounding advice provided in the product's documentation.

More information

Raymarine recommends that best practice is observed in all vessel electrical installations, as detailed in the following standards:

- BMEA Code of Practice for Electrical and Electronic Installations in Boats
- NMEA 0400 Installation Standard
- ABYC E-11 AC & DC Electrical Systems on Boats
- ABYC A-31 Battery chargers and Inverters
- ABYC TE-4 Lightning Protection

Power cable extension

The product is supplied with a power cable, which can be extended if required.

- The power cable for each unit in your system should be run as a separate, single length of 2-wire cable from the unit to the vessel's battery or distribution panel.
- Raymarine recommends a **minimum** wire gauge of 18AWG (0.82 mm²) for any length of cable extension.
- For all lengths of extension to the power cable, ensure there is a continuous **minimum** voltage at the product's power connector of 10.8 V with a fully flat battery at 11 V.

Important: Be aware that some products in your system (such as sonar modules) can create voltage peaks at certain times, which may impact the voltage available to other products during the peaks.

Grounding — Dedicated drain wire

The power cable supplied with this product includes a dedicated shield (drain) wire for connection to a vessel's RF ground point.

It is important that an effective RF ground is connected to the system. A single ground point should be used for all equipment. The unit can be grounded by connecting the shield (drain) wire of the power cable to the vessel's RF ground point. On vessels without an RF ground system the shield (drain) wire should be connected directly to the negative battery terminal.

The dc power system should be either:

- Negative grounded, with the negative battery terminal connected to the vessel's ground.
- Floating, with neither battery terminal connected to the vessel's ground



Warning: Product grounding

Before applying power to this product, ensure it has been correctly grounded, in accordance with the instructions provided.



Warning: Positive ground systems

Do not connect this unit to a system which has positive grounding.

4.5 SeaTalk^{ng}® connections

The MFD can connect to a **SeaTalk^{ng}®** backbone.

SeaTalk^{ng}® can be used to communicate with:

- **SeaTalk^{ng}®** instruments
- SeaTalk**SeaTalk^{ng}®** autopilots
- **SeaTalk** equipment via the optional **SeaTalk to SeaTalk^{ng}®** converter
- **NMEA 2000** equipment via optional **DeviceNet** adaptor cables

Typical SeaTalk^{ng}® system

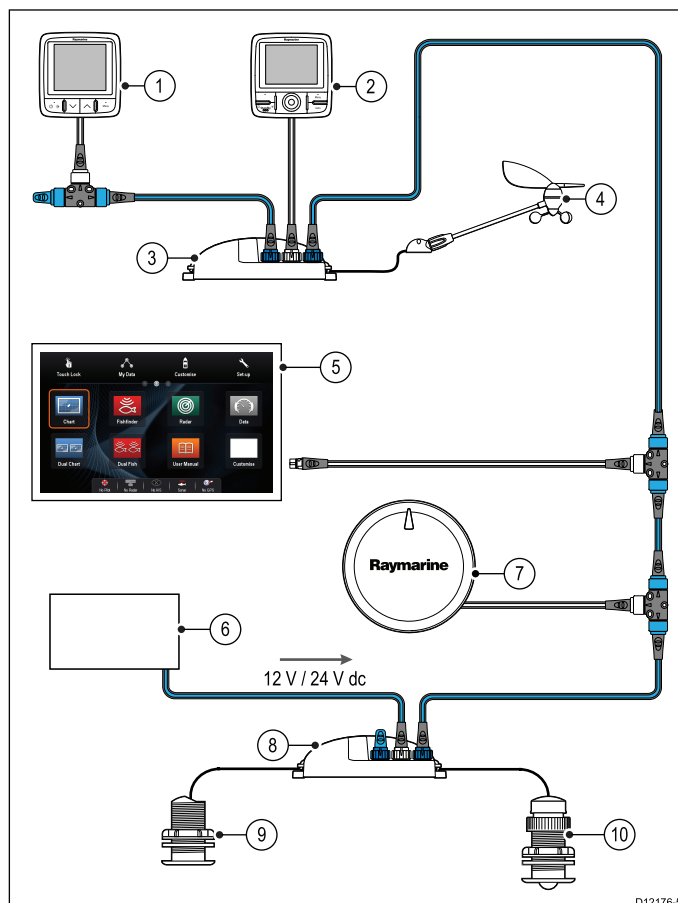

1. **SeaTalk^{ng}®** instrument
2. **SeaTalk^{ng}®** pilot control head
3. iTC-5 converter
4. Wind transducer
5. **MFD**
6. Power supply
7. **SeaTalk^{ng}®** autopilot
8. iTC-5 converter
9. Depth transducer
10. Speed transducer

For details of SeaTalk^{ng} cabling please refer to [Chapter 12 Spares and accessories](#).

SeaTalk^{ng} power requirements

The SeaTalk^{ng} bus requires a 12 V power supply.

Power may be provided from:

- Raymarine equipment with a regulated 12 V power supply (for example, a SmartPilot SPX course computer); or:

- Other suitable 12 V power supply.

Note: SeaTalk^{ng} does NOT supply power to multifunction displays and other equipment with a dedicated power supply input.

4.6 NMEA 2000 connection

The display can receive data from **NMEA 2000** devices (e.g. data from compatible engines). The **NMEA 2000** connection is made using **SeaTalk^{ng}** and appropriate adaptor cables.

You can EITHER:

- Use your **SeaTalk^{ng}** backbone and connect each **NMEA 2000** device on a spur, OR
- connect the display on a spur into an existing **NMEA 2000** backbone.

Important: You cannot have 2 backbones connected together.

Connecting NMEA 2000 equipment to the SeaTalk^{ng} backbone

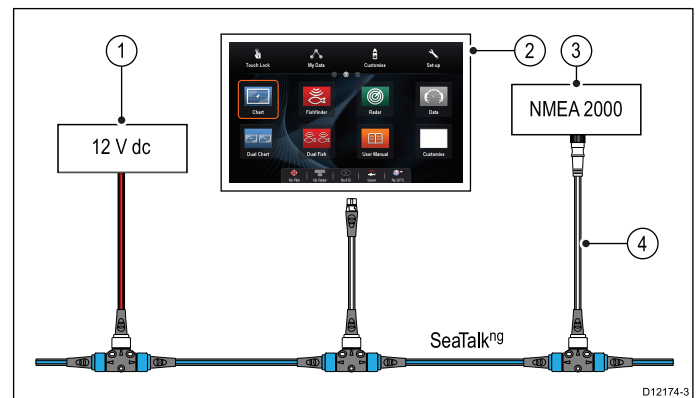

1. 12 V supply into backbone
2. **MFD**
3. **NMEA 2000** device
4. **SeaTalk^{ng}** to **DeviceNet** adaptor cable

Connecting the display to an existing NMEA 2000 (DeviceNet) backbone

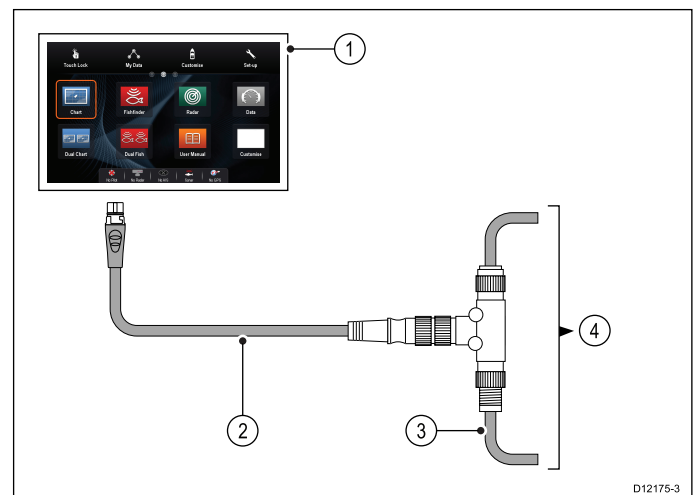

1. **MFD**
2. **SeaTalk^{ng}** to **DeviceNet** adaptor cable
3. DeviceNet backbone
4. **NMEA 2000** equipment

4.7 SeaTalk connection

You can connect **SeaTalk** devices to your MFD using the optional **SeaTalk to SeaTalk^{ng}** converter.

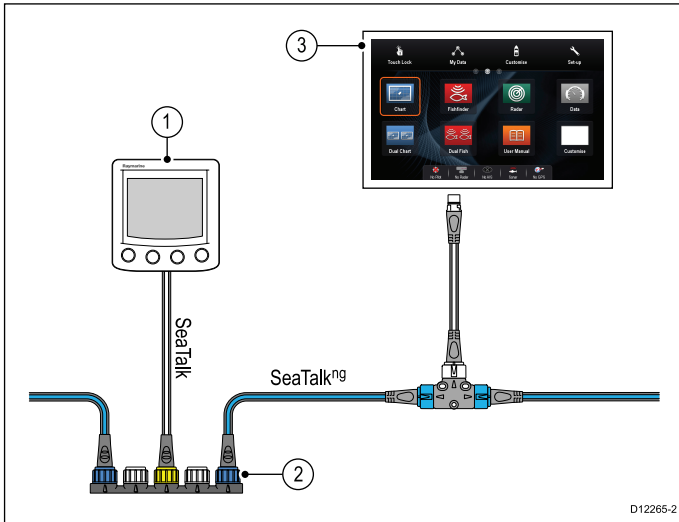

1. **SeaTalk** device
2. **SeaTalk to SeaTalk^{ng}** converter
3. **MFD**

4.8 NMEA 0183 connection — Power/NMEA/Video cable

NMEA 0183 devices can be connected directly to **MFDs** with a combined **Power/NMEA/Video** cable.

Refer to the *Connection Overview* section to establish the **NMEA 0183** connection method for your **MFD**.

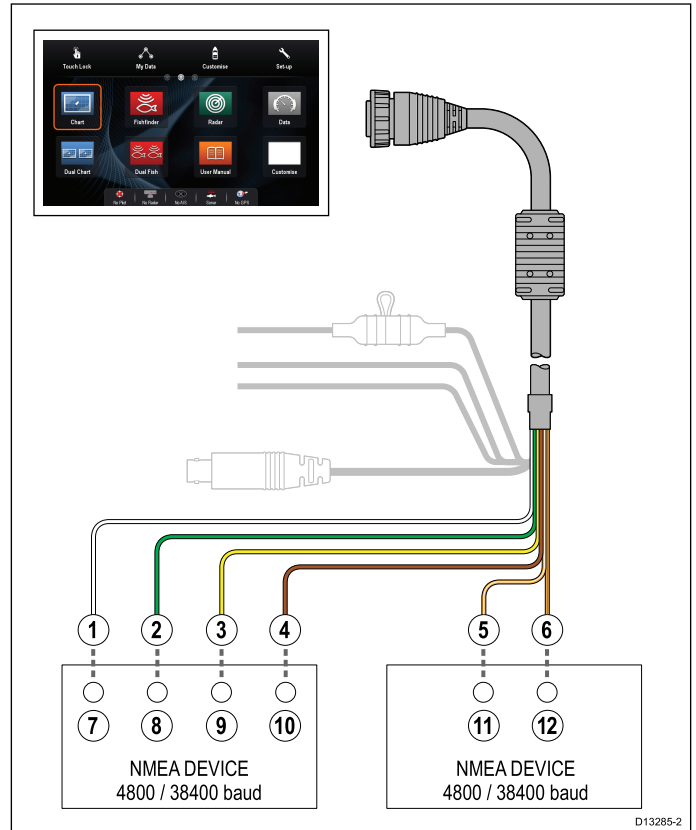

2 **NMEA 0183** ports are available:

- **Port 1:** Input and output, 4800 or 38400 baud rate.
- **Port 2:** Input only, 4800 or 38400 baud rate.

The baud rate for each input port must be specified in the **System Settings** menu (**Homescreen > Set-up > System Settings > NMEA Set-up > NMEA Input Port**).

Note: For Port 1, both the input and output communicate at the same baud rate. For example, if you have one **NMEA 0183** device connected to Port 1 INPUT, and another **NMEA 0183** device connected to Port 1 OUTPUT, both NMEA devices must use the same baud rate.

You can connect up to 4 devices to the display's output port and 2 devices to the display's input ports.

Item	Device	Cable color	Port	Input / output	Positive (+) / negative (-)
1	Multifunction display	White	1	Input	Positive
2		Green	1	Input	Negative
3		Yellow	1	Output	Positive
4		Brown	1	Output	Negative

Item	Device	Cable color	Port	Input / output	Positive (+) / negative (-)
5		Orange / white	2	Input	Positive
6		Orange / green	2	Input	Negative
7	NMEA device	*	*	Output	Positive
8		*	*	Output	Negative
9		*	*	Input	Positive
10		*	*	Input	Negative
11	NMEA device	*	*	Output	Positive
12		*	*	Output	Negative

Note: * Refer to instructions provided with the NMEA 0183 device.

NMEA 0183 connection — Video/NMEA cable

NMEA 0183 devices can be connected to MFD using the NMEA/Video input accessory cable (R70414)

Refer to the *Connection Overview* section to establish the NMEA 0183 connection method for your MFD.

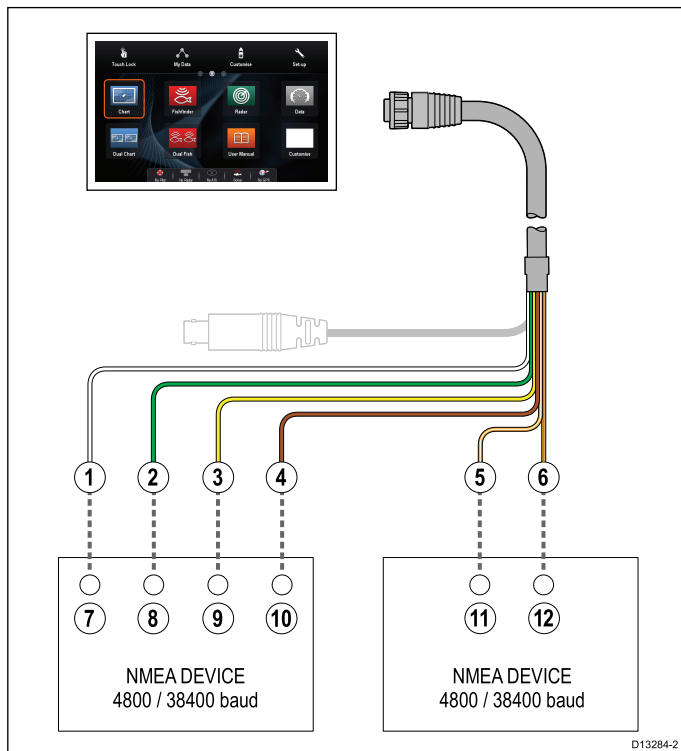

2 NMEA 0183 ports are available:

- **Port 1:** Input and output, 4800 or 38400 baud rate.
- **Port 2:** Input only, 4800 or 38400 baud rate.

The baud rate for each input port must be specified in the **System Settings** menu (**Homescreen > Set-up > System Settings > NMEA Set-up > NMEA Input Port**).

Note: For Port 1, both the input and output communicate at the same baud rate. For example, if you have one **NMEA 0183** device connected to Port 1 INPUT, and another **NMEA 0183** device connected to Port 1 OUTPUT, both NMEA devices must use the same baud rate.

You can connect up to 4 devices to the display's output port and 2 devices to the display's input ports.

Item	Device	Cable color	Port	Input / output	Positive (+) / negative (-)
1	Multifunction display	White	1	Input	Positive
2		Green	1	Input	Negative
3		Yellow	1	Output	Positive
4		Brown	1	Output	Negative
5		Orange / white	2	Input	Positive
6		Orange / green	2	Input	Negative
7	NMEA device	*	*	Output	Positive
8		*	*	Output	Negative
9		*	*	Input	Positive
10		*	*	Input	Negative
11	NMEA device	*	*	Output	Positive
12		*	*	Output	Negative

Note: * Refer to instructions provided with the NMEA 0183 device.

NMEA 0183 cable

You can extend the NMEA 0183 wires within the supplied power and data cable.

Data cable extension

Total length (max)	Cable
Up to 5 m	High quality data cable: <ul style="list-style-type: none"> • 2 x twisted pair with overall shield. • 50 to 75 pF/m capacitance core to core.

4.9 Sonar module and transducer connection

External sonar modules can be connected directly to the display's network connection or can be connected to the **SeaTalk^{hs}** network, via a **Raymarine[®]** network switch.

2 connections are required:

- **Network connection** — transmits the sonar data to a compatible **Raymarine[®]** MFD.
- **Transducer connection** — Internal and external sonar modules require connection to a compatible transducer. Internal 600 W and internal **CHIRP DownVision™** sonar variant displays feature a built-in module, enabling a compatible transducer to be connected directly to the display.

Network connection

Multiple sonar modules can be connected to the same network.

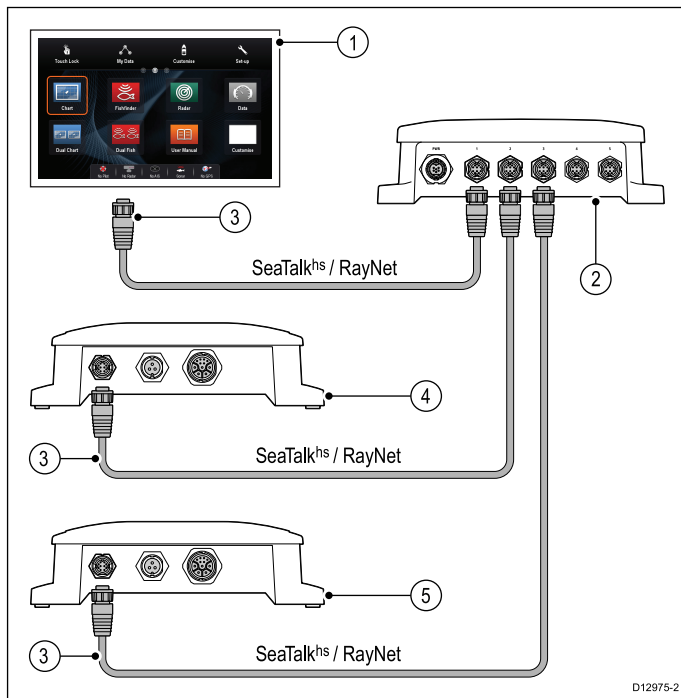

1. MFD
2. **Raymarine[®]** network switch
3. **RayNet** network cables
4. Sonar module 1 (e.g. **CHIRP** sonar module)
5. Sonar module 2 (e.g. **CHIRP DownVision™** sonar module)

Transducer connection — Internal 600 W MFD direct connection

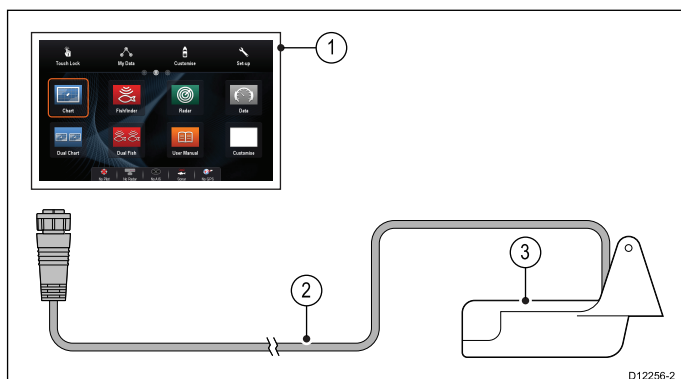

1. 600 W sonar variant MFD
2. 600 W MFD transducer

Refer to [12.2 Digital ClearPulse Transducers and accessories](#) for a list of transducer that can be connected directly to 600 W internal sonar variant MFDs.

Transducer connection – Internal 600 W MFD connection via optional adaptor cable

An optional adaptor cable is available to allow connection of external sonar module transducers to internal 600 W variant MFDs.

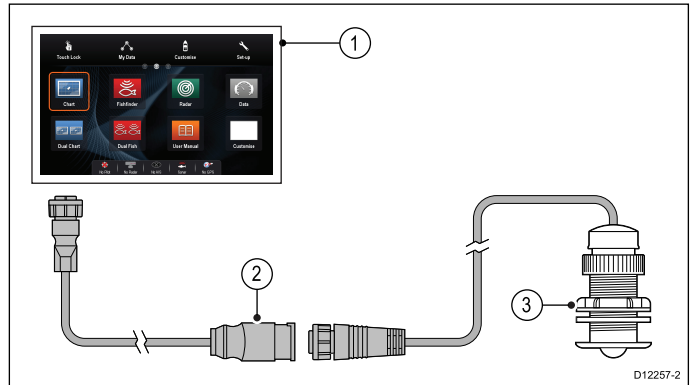

1. 600 W sonar variant MFD
2. Adaptor cable (E66066)
3. 600 W external sonar module transducer.

Transducer connection — CHIRP DownVision™ MFD direct connection

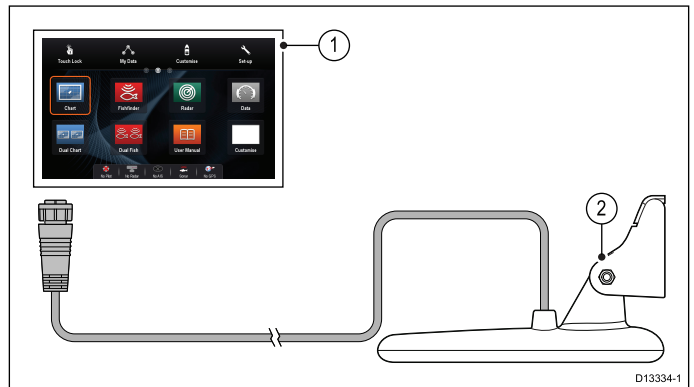

1. **CHIRP DownVision™** sonar variant MFD
2. **CHIRP DownVision™** Transducer

Refer to [12.3 DownVision™ transducers and accessories](#) for a list of transducer that can be connected directly to **CHIRP DownVision™** sonar variant MFDs.

Note: The **CPT200 SideVision™** transducer cannot be connected directly to a **DownVision™** variant MFD.

Transducer connection — Minn Kota transducer

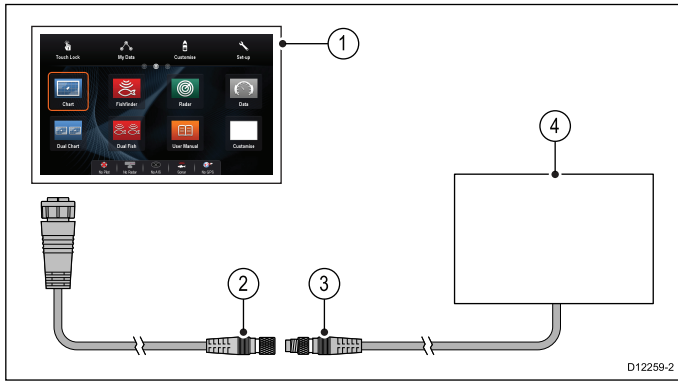

1. 600 W sonar variant **MFD**
2. Minn Kota transducer adaptor cable (A62363)
3. Minn Kota transducer cable
4. Minn Kota transducer

For further information regarding sonar module installation (including power connection and mounting), refer to the installation instructions supplied with the sonar module.

Sonar variant multifunction displays

600 W sonar variants	CHIRP DownVision™ variants
a67	a68
a77	a78
a97	a98
a127	a128
c97	eS78
c127	eS98
e7D	eS128
e97	
e127	
eS77	
eS97	
eS127	

Important software requirements for multiple sonar systems

If your system includes more than one source of sonar data you must ensure that any CP300 or CP450C sonar modules are running software version **v4.04** or later.

This applies to systems which include:

- Any number of MFD(s) with an internal sonar module plus a CP300 and / or CP450C sonar module; or
- No MFD(s) with an internal sonar module, but more than one CP300 or CP450C sonar module.

This does NOT apply to any systems that do NOT include a CP300 or CP450C sonar module.

Note: For software downloads and instructions on how to update the software for your product(s), visit www.raymarine.com/software.

4.10 Radar network connection

Radar units are connected to the **SeaTalk^{hs}** network, usually via a **Raymarine®** network switch. On smaller systems the Radar may be connected directly to the display's network connection.

Radar connected via network switch

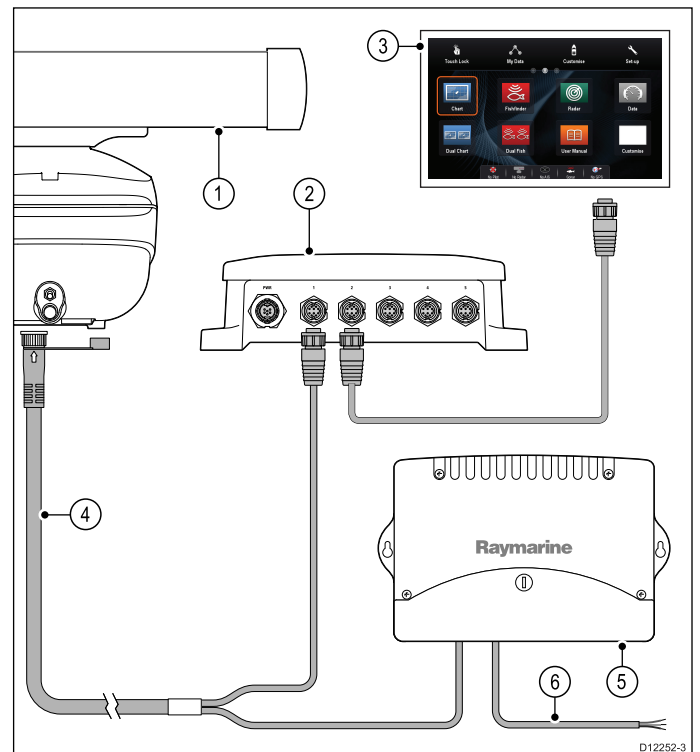

1. Radar scanner
2. **Raymarine®** network switch
3. **MFD**
4. **RayNet** Radar cable
5. VCM (Voltage Converter Module) — (required for Open Arrays)
6. Power connection

Radar connected directly to the display

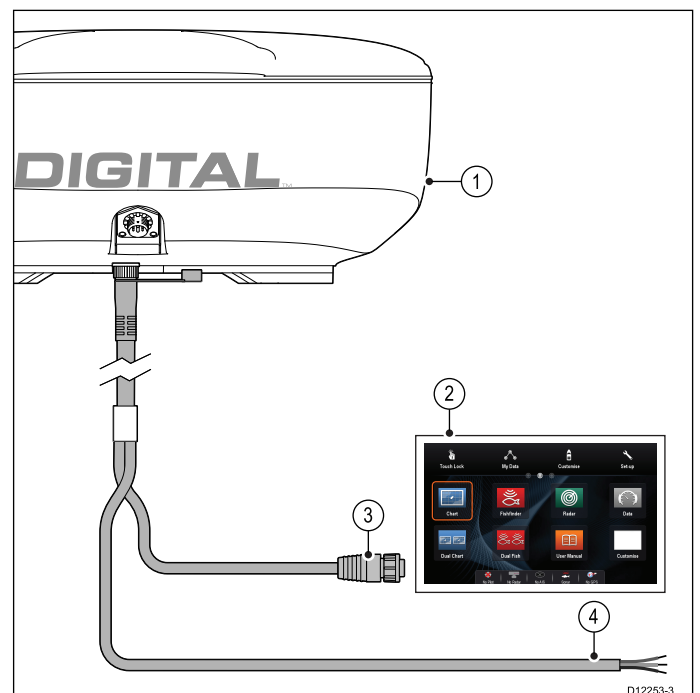

1. Radar scanner

2. **MFD**
3. Network connection to **MFD (RayNet Radar cable)**
4. Power connection

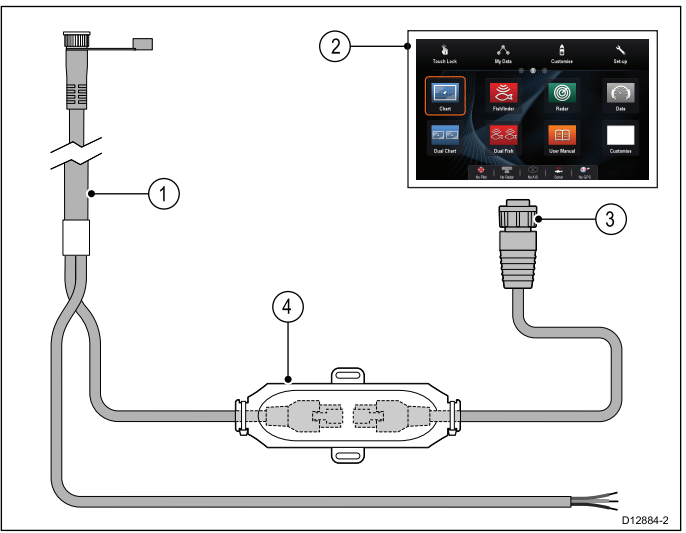

Note: Open array scanners require a VCM.

RJ45 SeaTalk^{hs} Radar cable connection

To connect a Radar using an RJ45 SeaTalk^{hs} Radar cable additional accessories are required.

1. RJ45 **SeaTalk^{hs}** Radar cable
2. **MFD**
3. Network connection to **MFD (RayNet to RJ45 SeaTalk^{hs} adaptor cable)**
4. **SeaTalk^{hs}** crossover coupler

Radar cable extension

For longer cable runs a Radar power and data digital cable extension is required.

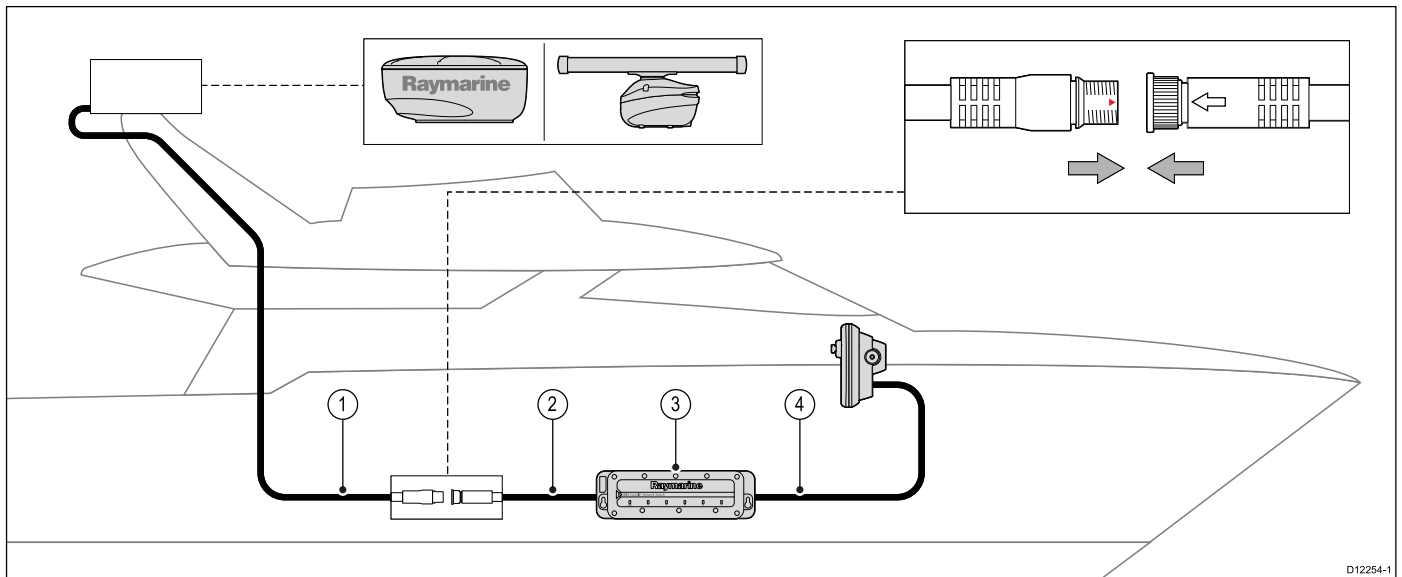

1. Radar extension cable.
2. Radar power and data digital cable.
3. **Raymarine®** network switch (or crossover coupler if connecting Radar directly to display).
4. **RayNet** cable (or **RayNet** to **SeaTalk^{hs}** cable, if connecting via a crossover coupler)

Note: The power connection is NOT shown in the diagram. If using an Open Array scanner a VCM (Voltage Converter Module) must be connected between the scanner and the power supply.

For further information regarding Radar installation (including power connections and mounting), refer to the installation instructions supplied with the Radar.

Digital radar cables

You will need a dedicated radar power and data digital cable and appropriate network cables to connect your scanner to your system.

Connection	Required cable
Radar scanner to power supply and Raymarine network switch.	Power and data digital cable. For longer cable runs, extensions are available in a variety of lengths.
Raymarine network switch to multifunction display.	Network cables, available in a variety of cable lengths.

SeaTalk^{hs} Radar power and data digital cables

These cables contain the wires for a scanner's power and data connections.

Cable	Part number
RJ45 SeaTalk ^{hs} 5 m (16.4 ft) Power and data digital cable	A55076D
RJ45 SeaTalk ^{hs} 10 m (32.8 ft) Power and data digital cable	A55077D
RJ45 SeaTalk ^{hs} 15 m (49.2 ft) Power and data digital cable	A55078D
RJ45 SeaTalk ^{hs} 25 m (82.0 ft) Power and data digital cable	A55079D

Note: The maximum length for the radar power and data digital cable (including any extensions) is 25 m (82 ft).

RayNet Radar power and data digital cables

These cables contain the wires for a scanner's power and data connections.

Cable	Part number
RayNet 5 m (16.4 ft) Power and data digital cable	A80227
RayNet 10 m (32.8 ft) Power and data digital cable	A80228
RayNet 15 m (49.2 ft) Power and data digital cable	A80229
RayNet 25 m (82.0 ft) Power and data digital cable	A80230

Note: The maximum length for the radar power and data digital cable (including any extensions) is 25 m (82 ft).

Radar power and data digital extension cables

These cables extend the power and data digital cables for a scanner's power and data connections.

Cable	Part number
2.5 m (8.2 ft) Power and data digital cable	A92141D
5 m (16.4 ft) Power and data digital cable	A55080D
10 m (32.8 ft) Power and data digital cable	A55081D

Note: The maximum length for the radar power and data digital cable (including any extensions) is 25 m (82 ft).

4.11 GA150 connection

If your **MFD** has a **GA150** connection, the external antenna can be connected to help improve the GNSS (GPS / GLONASS) receiver's reception.

Refer to the *Connection Overview* section to establish if your **MFD** can be connected to a **GA150**.

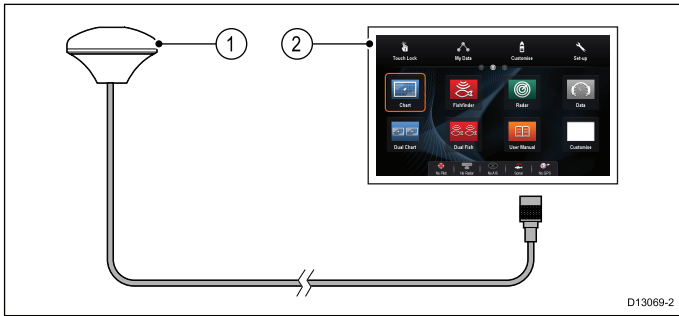

1. GA150 external antenna
2. **MFD**

For installation details for your external antenna, refer to the documentation that accompanied the antenna.

Antenna cable length

The GA150 is supplied with a fitted 10 m (33 ft.) cable. The length of the antenna cable can be extended if required.

The antenna cable length can be extended by up to 10 m (33 ft.) giving a total maximum cable length of 20 m (66 ft.)

50 ohm coaxial cable and reliable connectors (offering protection against water ingress) must be used when extending the antenna cable.

Note: Extending the cable length by more than the recommended maximum length will result in signal degradation.

Connecting an external antenna

Follow the steps below to connect the GA150 external antenna.

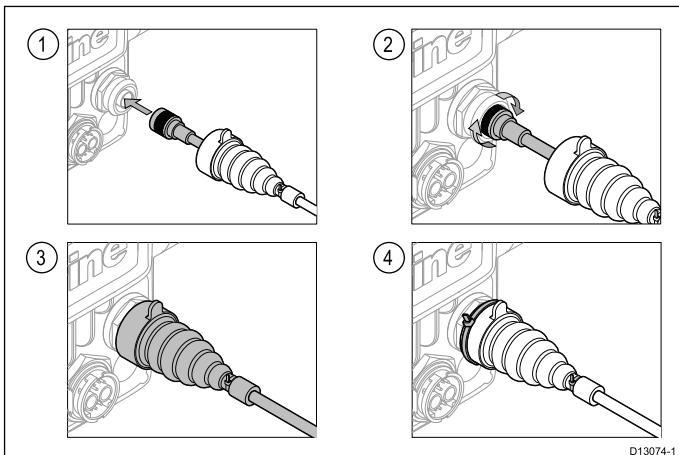

1. Fully insert the antenna's cable connector into the GA150 connector on the rear of your display.
2. Turn the locking collar clockwise until **TIGHT**.
3. Push to protective boot over the connection on the back of the display.
4. Use the supplied cable tie to secure the protective boot over the connection.

4.12 GNSS / GPS connection

Depending on display variant, your multifunction display may include an internal GNSS or GPS receiver. If required the multifunction display can also be connected to an external GNSS / GPS receiver, using **SeaTalk^{ng}**® or **NMEA 0183**.

GNSS / GPS connection — SeaTalk^{ng}®

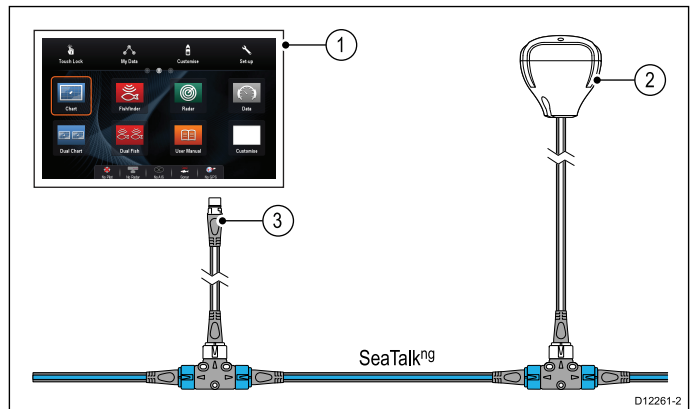

1. **MFD**
2. **SeaTalk^{ng}**® connection to **MFD**.
3. **SeaTalk^{ng}**® GNSS / GPS receiver.

An **NMEA 0183** GNSS / GPS receiver can be connected to the **MFD** by following the details provided in section [4.8 NMEA 0183 connection — Power/NMEA/Video cable](#) and the installation instructions provided with the unit.

4.13 AIS connection

A compatible AIS unit can be connected using **SeaTalk^{ng}**® or **NMEA 0183**.

Connection using SeaTalk^{ng}

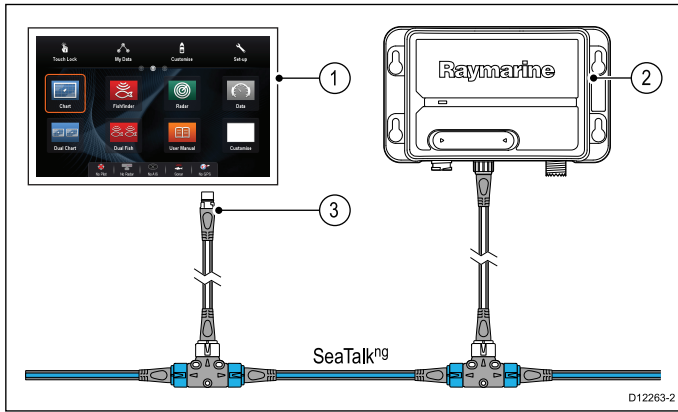

1. **MFD**
2. **SeaTalk^{ng}**® connection to **MFD**.
3. **SeaTalk^{ng}** AIS receiver / transceiver.

An AIS unit can be connected to the **MFD** by following the details provided in section [4.8 NMEA 0183 connection — Power/NMEA/Video cable](#) and the installation instructions provided with the unit.

4.14 Fastheading connection

If you wish to use MARPA (radar target acquisition) functions on your multifunction display you need either:

- An autopilot connected to the multifunction display via SeaTalk^{ng} or NMEA 0183. The compass is connected to the course computer and calibrated via the pilot control head; or:
- A Raymarine or third-party fastheading sensor connected to the multifunction display via NMEA 0183.

Note: Please contact your dealer or Raymarine technical support for more information.

4.15 Keypad network connection

Raymarine® remote keypads (e.g. the **RMK-9**) can be connected directly to the display's network connection or can be connected to the **SeaTalk^{hs}** network, via a **Raymarine®** network switch.

Multiple keypads can be connected to a system, with each keypad capable of controlling up to 4 **MFDs**.

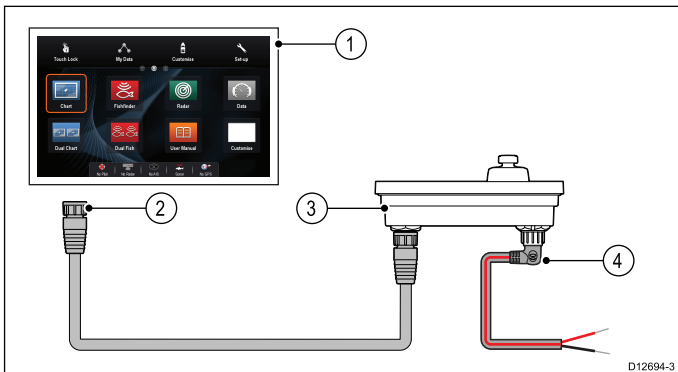

1. **MFD**
2. Network connection to **MFD** or **Raymarine®** network switch (**RayNet** cable)
3. **RMK-9** Keypad
4. Alternate power connection (Right angled power cable)

Note:

- a. When connecting the keypad directly to the **MFD**, unless the **MFD** is capable of providing power over ethernet the keypad must be powered separately, using the alternate power connection.
- b. When connecting the keypad via a network switch the keypad must be powered separately, using the alternate power connection.

For further information regarding keypad installation (including power connection and mounting), refer to the installation instructions supplied with the keypad.

Once connected the keypad must be paired with the each **MFD** you want it to control.

4.16 Weather receiver connection

A Sirius XM weather receiver can be connected directly to the display's network connection or can be connected to the **SeaTalk^{hs}** network, via a **Raymarine®** network switch.

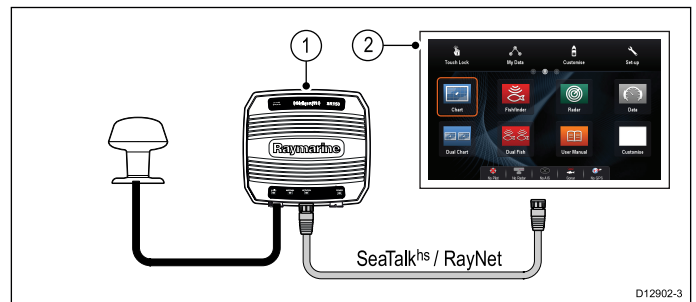

1. Raymarine weather receiver
2. **MFD**

For information on connecting an SR50 using SeaTalk^{ng} please refer to 82257 – *SR50 operation* which can be downloaded from the Raymarine website: www.raymarine.com.

For further information regarding weather receiver installation (including power connection and mounting), refer to the installation instructions supplied with the weather receiver.

4.17 HDMI video output

If your **MFD** has a HDMI output connection the **MFD's** screen can be output to an external display.

Refer to the *Connection Overview* section to establish if your **MFD** has a HDMI output.

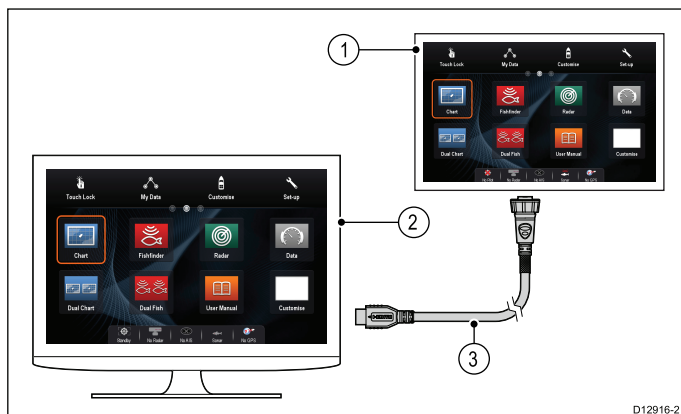

1. **MFD**
2. External display (See note below)
3. Raymarine 5 m (16.4 ft) HDMI video output cable (A80219)

Note:

1. The external display you are connecting to must support the 720p standard to enable you to view the multifunction display screen on the external display. The multifunction display's video output resolution is fixed at 720p.
2. The HDMI cable must only be connected to an external display that is electrically isolated from the vessel's dc power supply (i.e the screen and the 0V of the external display's HDMI connector must not have a direct connection to the vessel's dc power supply).

For further assistance please contact Raymarine technical support.

4.18 Video connection — composite

Analog cameras can be connected directly to **MFDs** that have a composite video input connection.

Refer to the *Connection Overview* section to establish if your **MFD** has a composite video input.

MFDs that do not have a composite video input connection can only be connected to IP cameras.

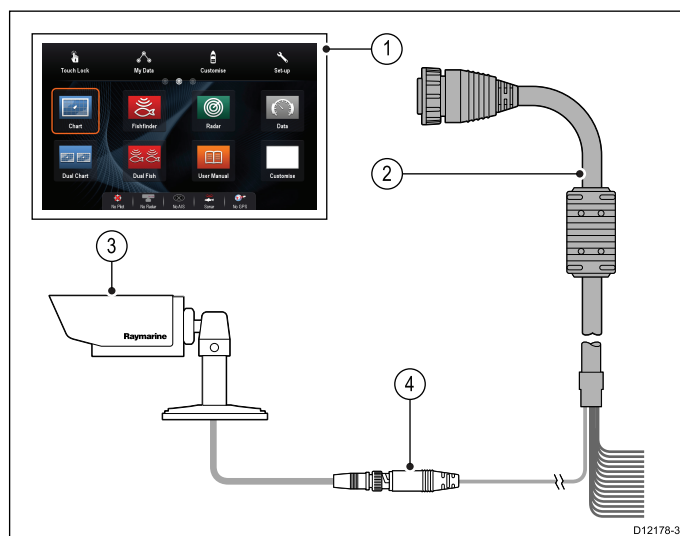

1. **MFD**
2. Connection to **MFD** (Power/NMEA/Video cable)
3. BNC video connector
4. Camera (video source)

Examples of other video sources that you can connect to the video in put connection:

- Thermal camera
- DVD player
- Portable media player

Note: To listen to audio, any connected player will require external speakers to be connected to the player's audio output.

Video specification

Signal type	Composite
Format	PAL or NTSC
Connector type	BNC (female)
Output resolution	720p

4.19 IP Camera connection

Raymarine® IP cameras can be connected directly to the display's network connection or can be connected to the **SeaTalk^{hs}** network, via a **Raymarine®** network switch.

The network connection transmits the video signal to a compatible **Raymarine®** MFD.

IP camera direct connection

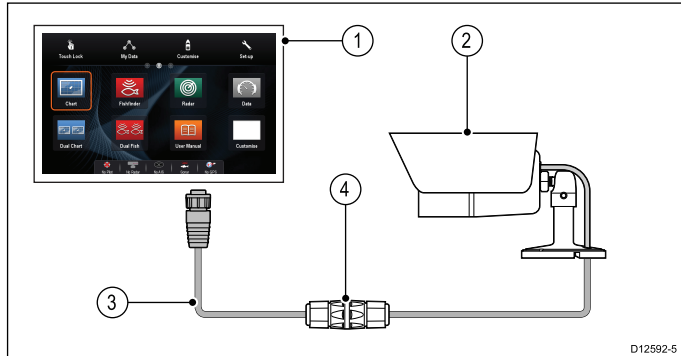

1. MFD
2. CAM200IP
3. RayNet to RJ45 SeaTalk^{hs} adaptor cable
4. Ethernet coupler (R32142)

IP camera network connection

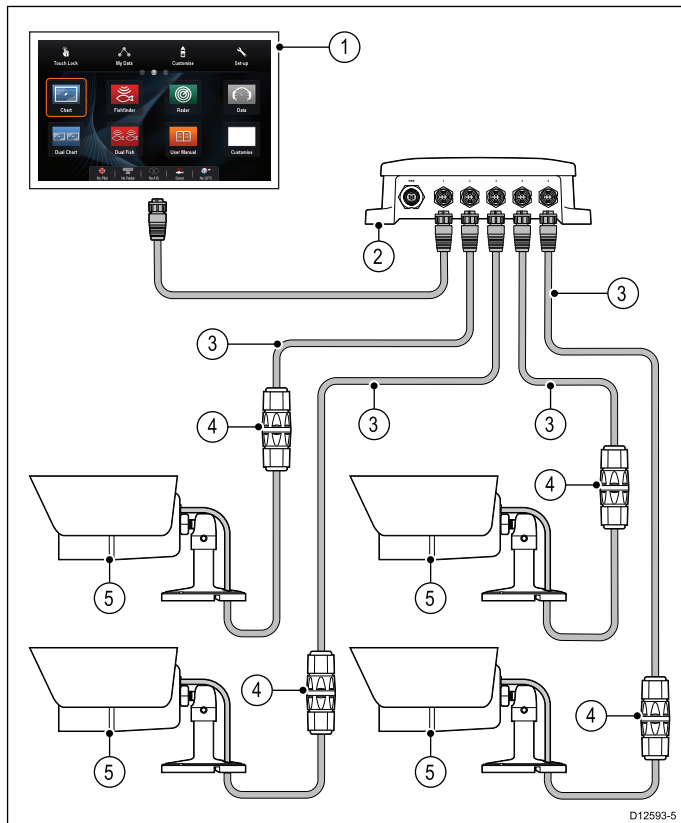

1. MFD
2. Raymarine® network switch
3. RayNet to RJ45 SeaTalk^{hs} adaptor cable
4. Ethernet coupler (R32142)
5. CAM200IP

Important: If your IP camera(s) are not detected by your multifunction display, try power cycling the IP camera(s) whilst leaving your multifunction display powered up.

For further information regarding camera installation (including power connection and mounting), refer to the installation instructions supplied with the camera.

IP camera guidance

Raymarine® MFDs are capable of displaying IP camera feeds. Whilst third-party IP cameras may work, **Raymarine®** highly recommends only using **Raymarine®** IP cameras such as the **CAM200IP**.

As guidance any third-party IP camera must conform to the following:

- The camera must support H.264 compression and RTSP (Real time Streaming Protocol).
- The camera must be ONVIF compliant
- The camera must be capable of and be setup to allow unauthenticated anonymous access
- The camera must be capable of and be setup to assign an IP address automatically via DHCP
- The camera resolution must be set to no higher than 720p

The camera settings must be checked and if necessary adjusted using a PC and the software supplied with the camera, prior to adding the camera to the **SeaTalk^{hs}** network.

Important: Raymarine® does not guarantee compatibility with third-party IP cameras.

4.20 Thermal camera connection

Thermal cameras can be connected directly to the display's network connection or can be connected to the **SeaTalk^{hs}** network, via a **Raymarine[®]** network switch.

2 connections are required:

- **Network connection** — required to control the thermal camera via a compatible **Raymarine[®]** **MFD** or optional Joystick Control Unit (JCU).
- **Video connection** — transmits the composite video signal to a compatible **Raymarine[®]** **MFD**.

Note: The Thermal camera can only be connected to **MFDs** with a Video input connection.

T200 Series connection

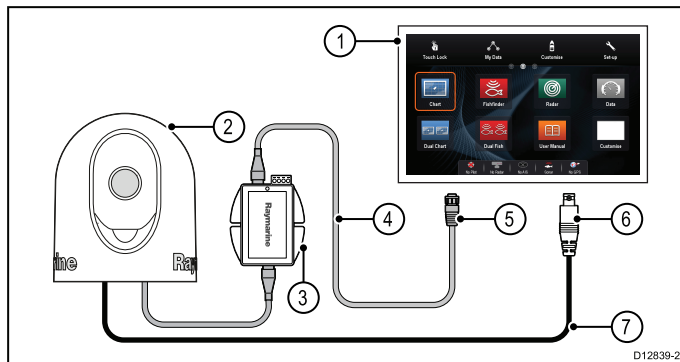

1. **MFD**
2. Thermal camera
3. Power over Ethernet (PoE) Injector
4. **RayNet** to RJ45 **SeaTalk^{hs}** adaptor cable
5. Network connection to **MFD (RayNet)**
6. Video connection to **MFD** (composite video)
7. Video cable

T300 / T400 Series connection.

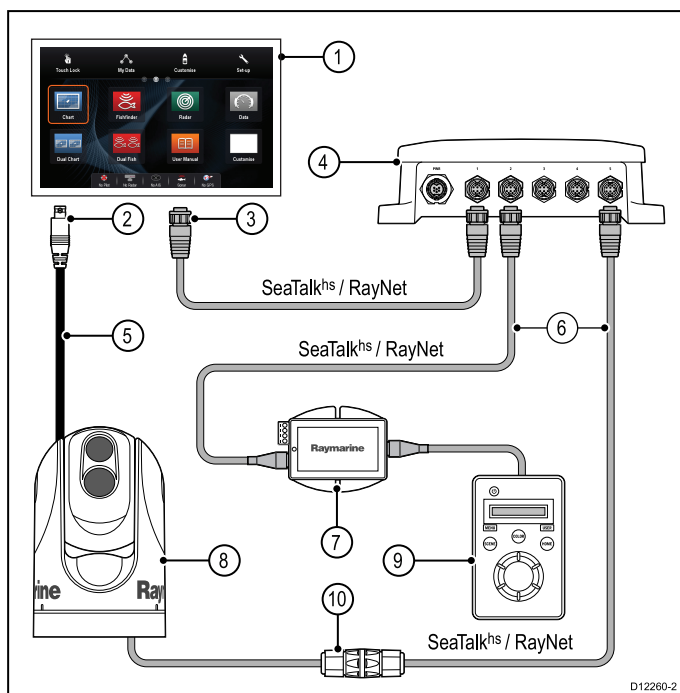

1. **MFD**
2. Video connection to **MFD** (composite video)

3. Network connection to **MFD (RayNet cable)**
4. **Raymarine[®]** network switch
5. Video cable
6. **RayNet** to RJ45 **SeaTalk^{hs}** adaptor cables
7. PoE (Power over Ethernet) injector (only required if using the optional JCU)
8. Thermal camera
9. Joystick Control Unit (JCU), optional
10. Ethernet coupler (R32142)

Important:

- You can only view the thermal camera image on the multifunction display to which the camera is physically connected. If you want to view the thermal camera image on more than 1 display you must obtain a suitable third-party video distribution unit.
- You can control the thermal camera using any multifunctional display connected to the same network. The Joystick Control Unit (JCU) is optional, but can be used in conjunction with multifunctional displays to control the thermal camera if required.
- “Dual payload” thermal cameras include 2 independent lenses; 1 for thermal (infrared) and 1 for visible light. If you only have 1 display you should only connect the video cable labelled “VIS / IR” (visible light / infrared) to the display. If you have 2 or more displays you should connect 1 cable to each display.

For further information regarding thermal camera installation (including power connection and mounting), refer to the installation instructions supplied with the camera.

Thermal camera cables

Cabling requirements for thermal cameras.

Camera to network switch

A network patch cable is required to connect the camera to the network switch. The connection is made between the camera cable tail and the network switch via the coupler (supplied with the camera). Network patch cables are available in a variety of lengths.

Joystick Control Unit (JCU)

An Ethernet (with power) cable is used to connect the JCU. The JCU is supplied with a 1.5 m (5 ft) Ethernet cable for this connection. If you require a different length contact your dealer for suitable cables.

Power over Ethernet (PoE) injector to network switch

A network patch cable is required for connecting the PoE injector to the network switch. Network patch cables are available in a variety of lengths.

Video cables

Video cables are not supplied with the product. Please contact your dealer for suitable cables and adaptors.

Raymarine recommends the use of a BNC terminated RG59 75ohm (or better) coaxial cable.

4.21 Fusion network connection

Fusion 700 and 750 Series marine entertainment systems can be connected directly to the display's network connection or can be connected to the **SeaTalk^{hs}** network, via a **Raymarine®** network switch. The Fusion entertainment system can be controlled by any MFD connected to the same network.

Multiple Fusion units can be connected to the same network.

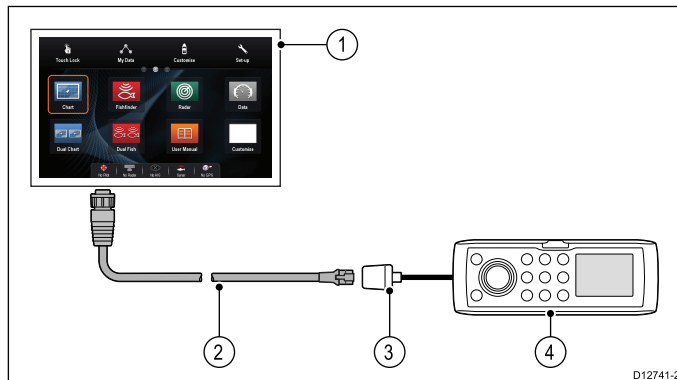

1. MFD
2. Network connection to MFD (RayNet to RJ45 SeaTalk^{hs} adaptor cable)
3. Fusion ethernet connection
4. Fusion unit

Note: The MFD should always be powered from a separate breaker and be powered on before any other connected devices.

For further installation information, refer to the installation instructions supplied with the unit.

4.22 Fusion NMEA 2000 connection

Compatible Fusion NMEA 2000 marine entertainment systems can be connected to the **SeaTalk^{ng}** backbone. The Fusion entertainment system can be controlled by any compatible **MFD** connected to the same backbone.

Multiple Fusion units can be connected to the same backbone.

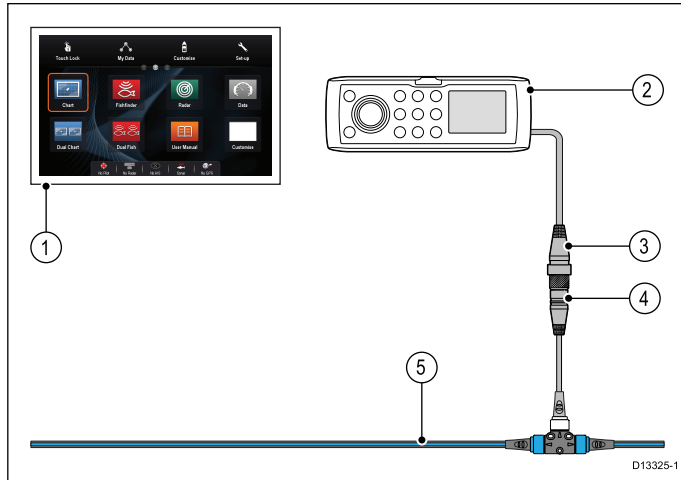

1. **MFD**
2. NMEA 2000 Fusion unit
3. Fusion NMEA 2000 connection
4. **SeaTalk^{ng}** to **DeviceNet** female adaptor cable (A06045)
5. **SeaTalk^{ng}** backbone

Note: The MFD should always be powered from a separate breaker and be powered on before any other connected devices.

For further installation information, refer to the installation instructions supplied with the unit.

Compatible Fusion units

The table below details the Fusion entertainment systems that are compatible with **Raymarine[®] LightHouse[™]** powered **MFDs**.

Fusion unit	NMEA 2000 connection	SeaTalk ^{hs} connection
650 Series	✓	✗
700 Series	✓	✓
750 Series	✓	✓
RA205 Series	✓	✗

4.23 Media player connection

You can use your **MFD** to control a Bluetooth media player (such as a smartphone).

The media player must be compatible with the Bluetooth 2.1+ EDR power class 1.5 (supported profile: AVRCP 1.0) or higher.

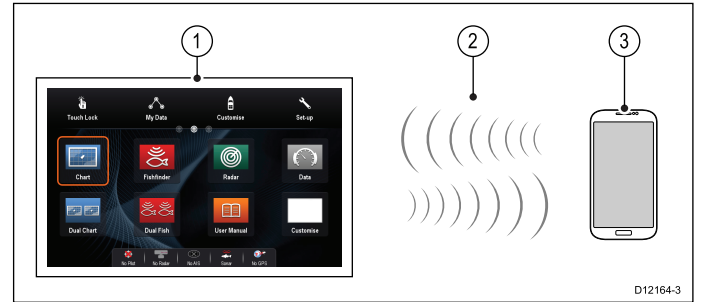

1. **MFD**
2. Bluetooth connection
3. Bluetooth media player

To use this feature you must first:

- Enable Bluetooth in the **System Settings** on the **MFD**.
- Enable Bluetooth on the media player device.
- Pair the media player device with the **MFD**.
- Enable **Audio Control** in the System Settings on the **MFD**.
- Connect an **RCU-3** remote and assign the shortcut key to Start/Stop audio playback (Only required on MFD that do not have a touchscreen).

Note: If your media player does not include built-in speakers it may be necessary to connect the media player's audio output to an external audio system or a pair of headphones. For more information refer to the instructions that accompany the media player device.

4.24 Raymarine mobile app connection

You can use compatible tablet and smartphone devices as a wireless repeat display or remote control for your multifunction display.

Raymarine apps allow you to stream and / or control, remotely what you see on your multifunction display to a compatible device, using a Wi-Fi connection.

To use this feature you must first:

- Ensure your device is compatible with the app you wish to use.
- Download and install the relevant Raymarine app, available from the relevant market store.
- Enable Wi-Fi in the System Settings on the multifunction display.
- Enable Wi-Fi on your compatible device.
- Select the Raymarine Wi-Fi connection from the list of available Wi-Fi networks on your compatible device.
- Enable the relevant Mobile app in the System Settings menu on the multifunction display.

Note: The multifunction display acts as a Wi-Fi access point. If your device already connects to an access point for e-mail and internet you must revert your access point back to regain access to e-mails and internet.

4.25 Bluetooth remote control connection

You can control the multifunction display wirelessly using a Raymarine remote control unit.

The remote control uses a Bluetooth wireless connection.

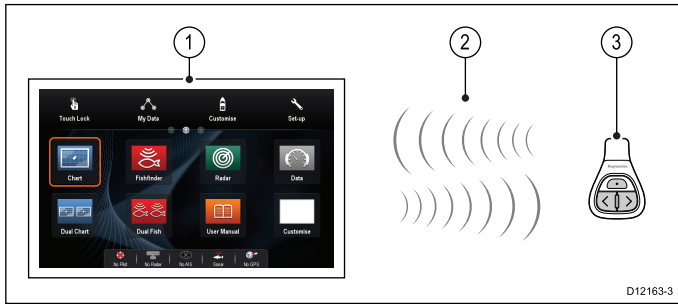

1. Multifunction display
2. Bluetooth connection
3. Raymarine Bluetooth remote control (for example, RCU-3)

To use the remote control you must first:

- Enable Bluetooth in the System Settings on the multifunction display
- Pair the remote control unit with the multifunction display

Operating principles

Remote control operating principles.

- Only 1 multifunction display may be operated by a remote control unit at any one time. You cannot pair a multifunction display to more than 1 remote control at the same time.
- The 3 buttons on the remote control unit have different functions depending on the CONTEXT in which you are using it. For example, in the chart application the buttons control different functions than they do in the homescreen.
- All functions are accessed using a combination of the 3 buttons. For some functions you must press a button **MOMENTARILY**. You can also **HOLD** a button for continuous response (for example, continuous ranging in the chart application).
- The main methods of operation involve the use of the **UP** and **DOWN** “arrow” buttons to highlight different on-screen options. The **SHORTCUT** button is used to select (execute) them.
- During the pairing process you must define which of the arrow buttons you want to be the “UP” button.
- The **SHORTCUT** button is customizable and can be configured to operate one of a number of functions, using the System Settings menu on your multifunction display.

Pairing the remote and configuring the UP and DOWN buttons

The remote control unit must be “paired” with the multifunction display that you want to control. On your multifunction display, with the homescreen displayed:

1. Select **Set-up**.
2. Select **System Settings**.
3. Select **Wireless Connections**.
4. Select **Bluetooth > On**.
5. Select **New Bluetooth Connection**.
A pop-up message will be displayed to confirm that the device you are connecting to is discoverable.
6. Select **Ok** to confirm.
A list of discovered devices is displayed.
7. On your **remote control unit**, hold down the UP and DOWN buttons together for 10 seconds.
8. Select the remote control unit in the list of devices.
9. When prompted, press the arrow button on your remote that you wish to be configured as the UP button. The other arrow button will automatically be configured as the DOWN button.
If the pairing was successful a “Pairing Success” message will be displayed. If a “Pairing Failure” or “Pairing Timeout” message is displayed, repeat steps 1 to 8.

Remote control functions

Buttons

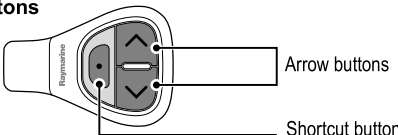

Arrow buttons
Shortcut button

Range



Pair



Select



D12051-3

	Button	Application where function available:				
		Chart	Radar	Fishfinder	Weather	Home-screen
Default functions:						
Range / zoom.	<ul style="list-style-type: none"> Press UP or DOWN arrow for momentary response. Hold UP or DOWN arrow for continuous response. 	✓	✓	✓	✓	✗
Open homescreen.	Shortcut: Hold	✓	✓	✓	✓	✗
Select application in homescreen (in left-to-right, top-to-bottom order).	<ul style="list-style-type: none"> Press UP or DOWN arrow for momentary response. Hold UP or DOWN arrow for continuous response. 	✗	✗	✗	✗	✓
Toggle menu items and options in dialogs and prompts (in left-to-right, top-to-bottom order).	<ul style="list-style-type: none"> Press UP or DOWN arrow for momentary response. Hold UP or DOWN arrow for continuous response. 	✓	✓	✓	✓	✓
Place waypoint at vessel position.	Shortcut	✓	✓	✓	✓	✗
Media player control (requires a Bluetooth media player paired to the multifunction display).	<ul style="list-style-type: none"> Press UP / DOWN arrow for next / previous track. Press SHORTCUT button for play / pause. 	✓	✓	✓	✓	✓
Customizable functions:						

	Button	Application where function available:				
Open homescreen.	SHORTCUT	✓	✓	✓	✓	✗
Switch active application (only available when multiple applications are displayed).	SHORTCUT	✓	✓	✓	✓	✗

Reconnecting the RCU

1. When you pair the RCU-3 with a multifunction display a wireless connection is established.

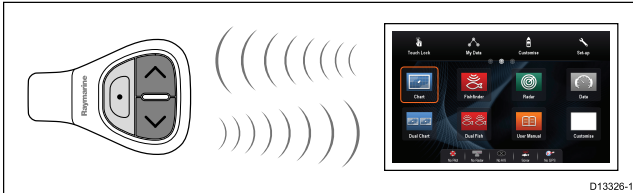

2. When you power off the multifunction display it loses its connection with the RCU-3 after 10 minutes.

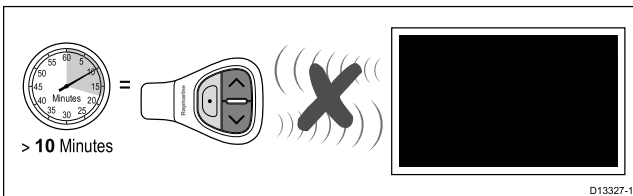

3. To restore the connection between the 2 units, press and hold any button on the RCU-3 for at least 3 seconds.

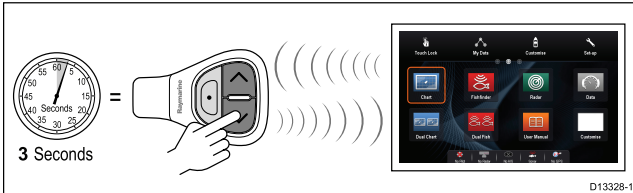

Note: You will also need to reconnect the RCU-3 as described above if you disable and then re-enable the Bluetooth connection on the multifunction display at any time.

Customizing the SHORTCUT button

On your multifunction display, with the homescreen displayed:

1. Select **Set-up**.
2. Select **System Settings**.
3. Select **External Devices**.
4. Select **Remote Control**.
5. Select **Customize shortcut key**.
6. Select the function that you want to assign to the **SHORTCUT** key.

Chapter 5: Mounting

Chapter contents

- [5.1 Surface mounting on page 58](#)
- [5.2 Bracket \(trunnion\) mounting on page 59](#)
- [5.3 Rear flush mount kit on page 60](#)

5.1 Surface mounting

The display can be surface mounted.

Before mounting the unit, ensure that you have:

- Selected a suitable location.
- Identified the cable connections and route that the cables will take.
- Detached the Menu/Home buttons keypad.
- Detached the front screw covers.

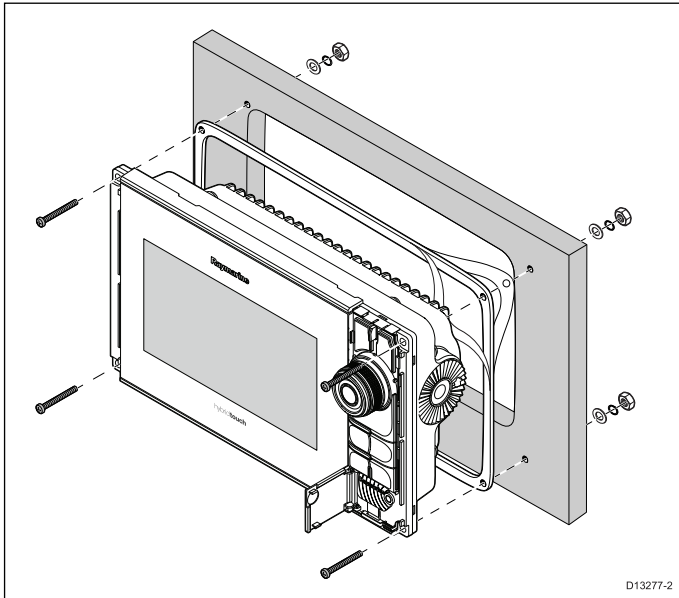

1. Check the selected location for the unit. A clear, flat area with suitable clearance behind the panel is required.
2. Fix the appropriate cutting template, supplied with the product to the selected location, using masking or self-adhesive tape.
3. Using a suitable hole saw (the size is indicated on the template), make a hole in each corner of the cut-out area.
4. Using a suitable saw, cut along the inside edge of the cut-out line.
5. Ensure that the unit fits into the removed area and then file around the rough edge until smooth.
6. Drill 4 holes as indicated on the template to accept the fixings.
7. Place the gasket onto the rear of the display and press firmly onto the flange.
8. Connect the power, data and other cables to the unit.
9. Slide the unit into place and secure using the fixings provided.
10. Attach the Menu/Home buttons keypad, by sliding it down from above the display.

11. Attach the screw covers, by sliding in from either side of the display.

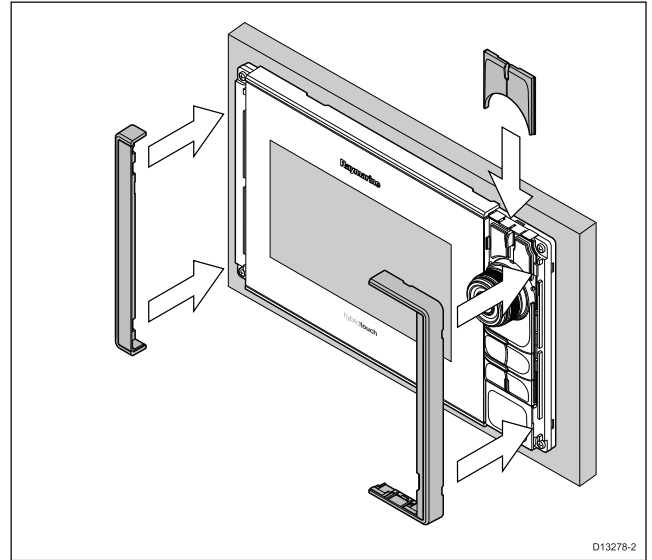

Note: The supplied gasket provides a seal between the unit and a suitably flat and stiff mounting surface or binnacle. The gasket should be used in all installations. It may also be necessary to use a marine-grade sealant if the mounting surface or binnacle is not entirely flat and stiff or has a rough surface finish.

Fitting the Menu-Home button

Follow the steps below to fit the Menu/Home button to the display.

1. Squeeze the top of the button assembly between your fingers and thumb.

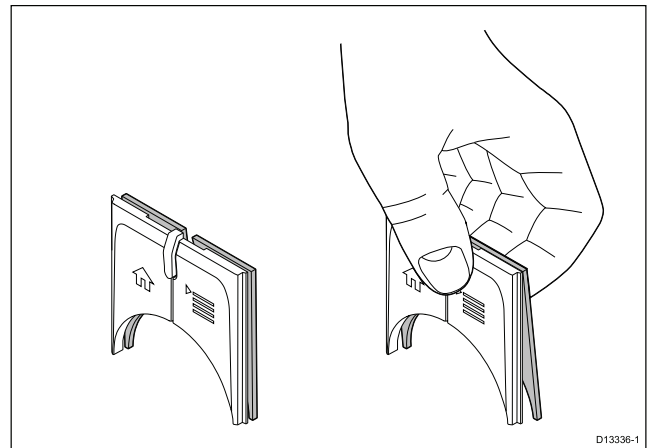

Squeezing the top will lever the bottom of the backing plate farther away from the buttons, creating a bigger gap to enable the assembly to be fitted.

- Slide the backing plate behind the locating tabs as shown below.

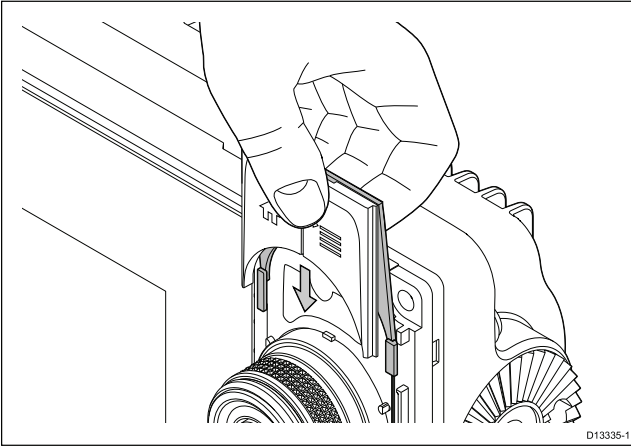

Removing the screw covers

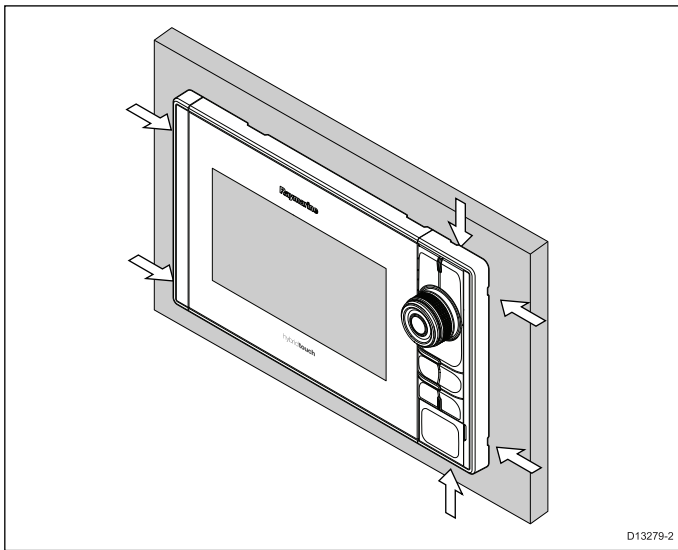

- Carefully insert the tip of a small flat blade screw driver into the recesses around the edge of the screw covers.
- Gently lever the screw driver to push the screw cover forward, away from the display.

The cover should now come away from the display easily.

5.2 Bracket (trunnion) mounting

The display can be mounted on a trunnion bracket.

Before mounting the unit ensure that you have:

- Selected a suitable location.
- Identified the cable connections and route that the cables will take.
- Attach the screw covers.

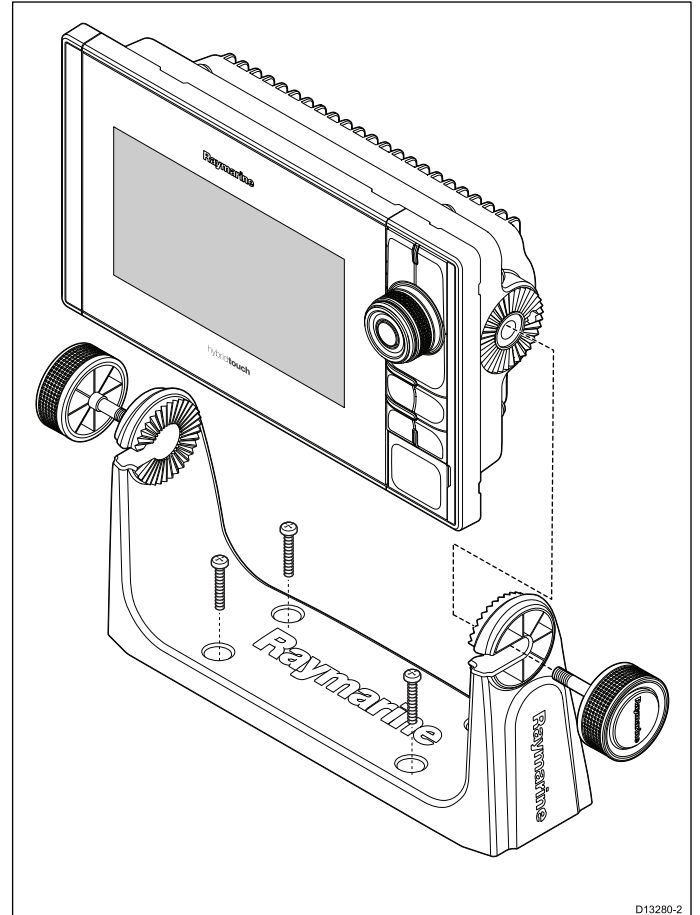

- Mark the location of the mounting bracket screw holes on the chosen mounting surface.
- Drill holes for the fixings using a suitable drill, ensuring there is nothing behind the surface that may be damaged.
- Use the fixings supplied with the mounting bracket to attach securely.
- Attach the display to the mounting bracket.

5.3 Rear flush mount kit

eS Series displays can be flush mounted from the rear.

Instructions on how to flush mount the display from the rear are provided with the kit.

Description	Part number
eS7 Rear mounting kit	A80341
eS9 Rear mounting kit	A80342
eS12 Rear mounting kit	A80343

Chapter 6: Getting started

Chapter contents

- [6.1 Switching the unit on and off on page 62](#)
- [6.2 eS Series Controls on page 63](#)
- [6.3 Basic touchscreen operations on page 64](#)
- [6.4 Multi-Touch gestures on page 64](#)
- [6.5 Touch icons on page 65](#)
- [6.6 Homescreen overview — HybridTouch and non-Touch displays on page 65](#)
- [6.7 Pages on page 67](#)
- [6.8 Applications on page 69](#)
- [6.9 Splitscreen controls on page 70](#)
- [6.10 Screen overview on page 71](#)
- [6.11 Initial set up procedures on page 74](#)
- [6.12 GNSS Status on page 76](#)
- [6.13 Enabling autopilot control on page 79](#)
- [6.14 Engine identification on page 80](#)
- [6.15 Enabling AIS functions on page 82](#)
- [6.16 Shared preferences on page 82](#)
- [6.17 Memory cards and chart cards on page 83](#)
- [6.18 Simulator mode on page 83](#)
- [6.19 Pairing the keypad on page 84](#)
- [6.20 System software updates on page 84](#)
- [6.21 Learning resources on page 86](#)

6.1 Switching the unit on and off

Powering the display on

1. Press the **POWER** button on the display.
2. Select **Accept** to acknowledge the disclaimer message.

Powering the unit off

1. Press and hold the **Power** button for approximately 6 seconds.
On display products a 3 second count-down timer will be displayed.
To cancel the power off process, release the power button before the unit powers off.

Note: The unit will still draw a small amount of power from the battery when powered off, if this is a concern unplug the connector from the back of the unit.

PowerSave mode

In PowerSave mode all functions of the multifunction display remain active, but the unit is placed into a low power state. The LED lights around the Rotary controller will blink once every 1.5 seconds to indicate that the unit is in PowerSave mode. PowerSave mode is cancelled by pressing a physical button or when an alarm event occurs.

Note: To ensure user safety the PowerSave feature will not be available if:

- any connected Radars are switched on
- the multifunction display is providing autopilot control in a system without a dedicated pilot head and the autopilot is engaged.

Attention Leaving an **MFD** in PowerSave mode will continue to consume some power from your vessel's batteries. The unit could drain your batteries if left in PowerSave mode for prolonged periods of time. When switching off the power to your vessel, ensure that the unit is powered off using the power button. For more information on the amount of power consumed by the unit in PowerSave mode, refer to the Technical specification section of your product's installation instructions.

Enabling PowerSave mode

To enable PowerSave mode follow the steps below.

1. Ensure any radars connected to the system are switched off.
2. Press the **POWER** button.
The shortcuts menu is displayed.
3. Select **PowerSave Mode**.
The multifunction displays is now in PowerSave mode.
4. You can wake the unit from PowerSave mode at anytime by pressing a physical button on the multifunction display.

Note: PowerSave mode is automatically cancelled if an alarm event occurs.

Adjusting the display brightness

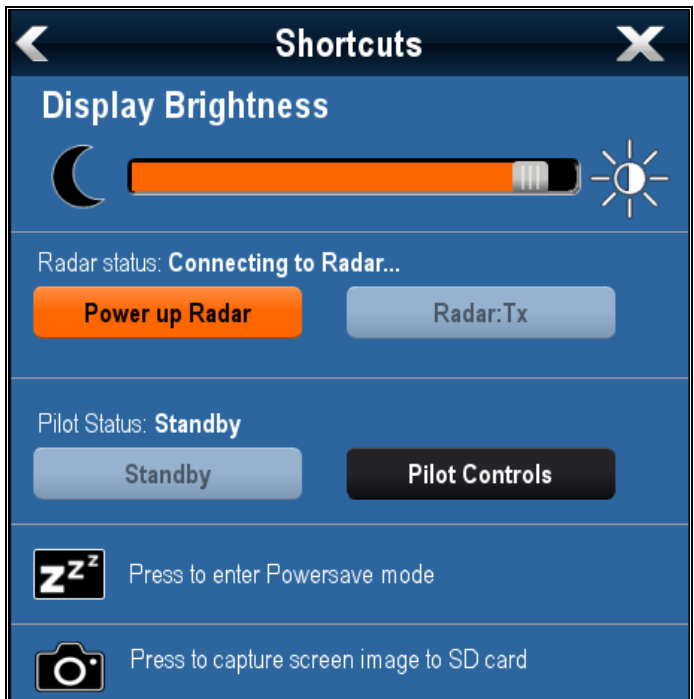

1. Press the **POWER** button once.
The Shortcuts menu is displayed.
2. Adjust the brightness to the required level using the on-screen brightness slider bar control, or
3. Touch the Sun icon to increase the brightness level or the Moon icon to decrease the brightness level.

Note: The brightness level can also be increased by pressing the **Power** button multiple times.

Adjusting the display brightness

1. Press the **POWER** button once.
The Shortcuts menu is displayed.
2. Adjust the brightness to the required level using the **Rotary control**.

Note: The brightness level can also be increased by pressing the **Power** button multiple times.

6.2 eS Series Controls

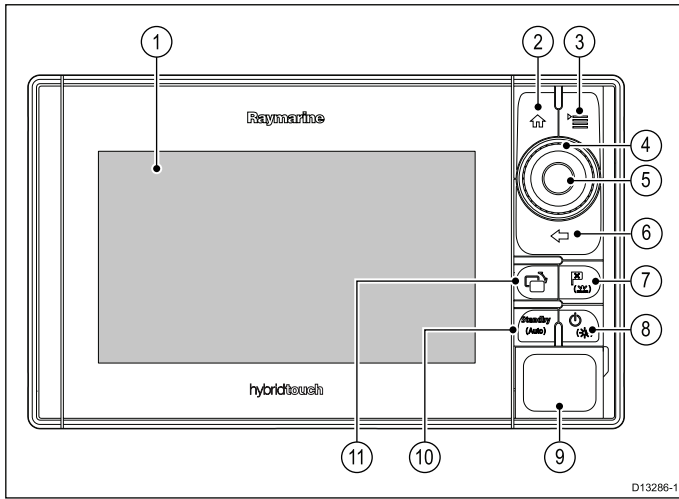

	Description	Functions
1	Touch-screen	you can touch the screen to operate many common functions, including all menu operations.
2	Home	Press to return to the homescreen.
3	Menu	Accesses menus. Press again to close menus.
4	UniControl	Provides rotary and joystick control.
5	Ok	Ok push button
6	Back	Press to return to a previous menu or dialog level.
7	WPT / MOB	<ul style="list-style-type: none"> Press and release to access the waypoint options. Press again to place a waypoint. Press and hold to place a Man Overboard (MOB) marker at your current position.
8	Power	<ul style="list-style-type: none"> Press once to switch the unit ON. Once powered on, press the Power button again to adjust the brightness, perform a screen capture, access Powersave mode or access the power controls for external devices. Press and hold to switch the unit OFF.
9	Card reader slot	Open the card door to insert or remove a MicroSD card. There are 2 card slots (labelled 1 and 2), used for electronic charts and archiving waypoint, route, track and settings data.
10	Pilot	<ul style="list-style-type: none"> Press to disengage integrated autopilot. Press and hold to activate Auto mode on integrated autopilot.
11	Switch Active Pane	Press to switch the active pane (in splitscreen pages).

eS Series UniController

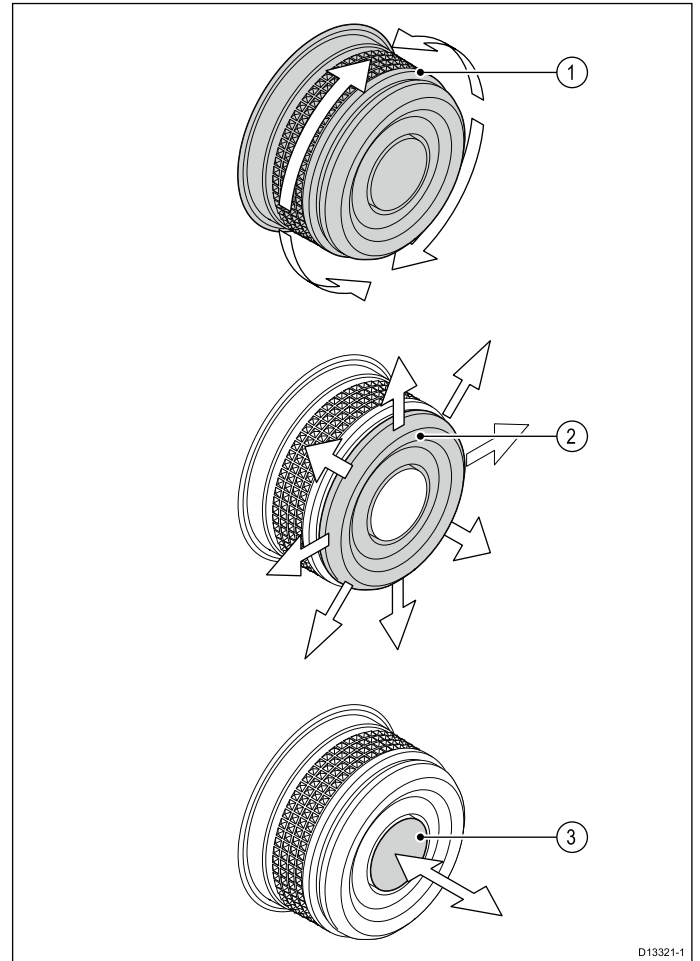

1. **Rotary** — use to select menu items, move the onscreen cursor, and adjust the range in the Chart and Radar applications.
2. **Directional control** — use to move the cursor position in applications, pan up, down, left and right in the Chart, Weather and Fishfinder applications or to cycle through datapages in the Data application.
3. **OK** push button — push in to confirm a selection or entry.

6.3 Basic touchscreen operations

Placing and moving the cursor using touch

To place or move the cursor around the screen on a touchscreen multifunction display follow the steps below.

1. Touch the screen at any position on the screen to place the cursor there.

Touchscreen lock

On a multifunction display with HybridTouch you can lock the touchscreen to prevent accidental use.

For example, locking the touchscreen is particularly useful in rough water or weather conditions.

The touchscreen can be locked and unlocked from the homescreen. The touchscreen can only be unlocked using physical buttons.

Locking the touchscreen – HybridTouch displays

On HybridTouch multifunction displays the Homescreen contains a dedicated Touch Lock icon.

With the homescreen displayed:

1. Select the **Touch Lock** icon.
It changes color to indicate that the touchscreen is disabled. All functions are still available using the physical buttons.

 Touch Lock	Touchscreen is locked. All functions remain available using physical buttons.
--	---

Unlocking the touchscreen – HybridTouch displays

You can unlock the touchscreen by following the steps below.

With the hHomescreen displayed:

1. Use the UniControl to highlight the **Touch Lock** icon.
2. Press the **OK** button.

The Touchscreen is enabled.

 Touch Lock	Touchscreen is unlocked.
--	--------------------------

6.4 Multi-Touch gestures

Raymarine a Series and gS Series multifunction displays support multi-touch.

Multi-touch means that the display is capable of recognizing multiple simultaneous touch inputs. This means that you can use 2 or more fingers on the screen at the same time to perform multi-touch gestures.

Pinch to Zoom

The pinch to zoom gestures can be performed on multifunction displays that support multi-touch.

Pinch to zoom consists of 2 actions:

- Move 2 fingers apart to zoom in.
- Move 2 fingers together to zoom out.

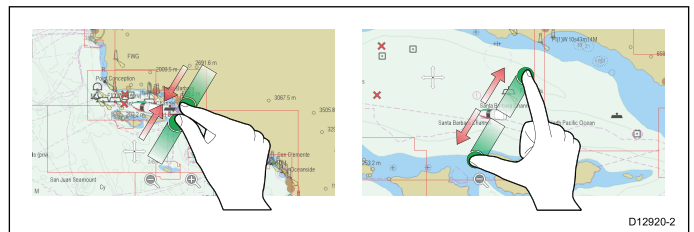



Pinch to Zoom can be used in the following applications:

- Chart application.
- Weather application.

6.5 Touch icons

Touchscreen multifunction displays can use the **BACK** and **CLOSE** icons to move between the different levels of menus available in each application.

	Back — go back one level (same effect as pressing the BACK button).
	Close — close all open menus (same effect as pressing the MENU button).

Using the cursor

The cursor is used to move around the screen.

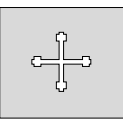
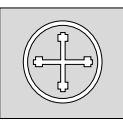
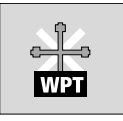
	The cursor appears on the screen as a white cross.
	If the cursor has not been moved for a short period of time, it changes to a circle with a cross in it, to make it easier to locate on the screen.
	The cursor is context-sensitive. When it is placed over an object such as a waypoint or chart feature, it changes color and a label or information associated with the object is displayed.

List of cursor labels

Label	Feature	Application
A/B	Ruler line	Chart
AIS	AIS target	Chart
COG	Course Over Ground vector	Chart
CTR	Center of radar	Radar
FLT	Floating EBL/VRM	Radar
GRD	Guard zone	Radar
HDG	Heading vector	Chart
MARPA	MARPA target	Radar
MOB	Man Over Board marker	Chart, Radar
POS	Vessel's position	Chart
RTE	Route leg	Chart
SHM	Ship's Heading Marker	Radar
TIDE	Tide indicator	Chart
TRACK	Track line	Chart
VRM/EBL	VRM and EBL, 1 or 2	Radar
WIND	Wind indicator	Chart
WPT	Waypoint	Chart, Radar

6.6 Homescreen overview — HybridTouch and non-Touch displays

The Homescreen provides a central point of access for your display's applications, data and settings.

- The Homescreen provides quick access to your data (waypoints, routes, tracks, images and videos) and backup settings.
- The Homescreen consists of a number of Homescreen pages. Swipe the screen left or right with your finger to scroll through the available Homescreen pages.
- Each Homescreen page consists of a number of icons. Applications are started by selecting the relevant icon.



Screen item	Description
1	Touch Lock — (HybridTouch displays only) select this icon to lock the touchscreen, preventing accidental use. To unlock, use the UniControl to deselect the Touch Lock icon.
2	My Data — this icon enables you to centrally manage your data including route, track, and waypoint lists. You can also access saved pictures and videos and backup settings.
3	Customize — select this icon to configure application pages and display preferences.
4	Set-up — select this icon to access the system set-up menus.
5	Icon — each icon represents an application page. A page can display multiple applications simultaneously.
6	Status bar — the status icons confirm the status of externally-connected equipment, including GPS, AIS, radar, sonar and autopilot units.

Accessing the homescreen

The homescreen can be accessed from any application.

- To access the homescreen follow the steps below:
1. Select the homescreen icon on-screen.



Accessing the homescreen

The homescreen can be accessed from any application.

To access the homescreen follow the steps below:

1. Press the **Home** button.

Note: The e7 and e7D have a combined Menu and Home button, to access the homescreen press and hold the **Menu / Home** button for 3 seconds.

Databar status symbols

The status symbols on the databar confirm whether the appropriate connections to your system have been made.

The symbols show the status for the following:

- Radar scanner.
- AIS receiver / transceiver.
- Sonar module.
- GPS receiver.
- Autopilot.

Autopilot status symbols

The autopilot status is indicated in the databar.

Symbol	Description
	Autopilot is in Standby mode.
	Autopilot is in Track mode.
	Autopilot is in Auto mode.
	No autopilot detected.
	Autopilot alarm active.
	Dodge mode is active.
	Fish mode is active.
	Autopilot calibration.
	Power steering active.
	Wind Vane mode is active.

Radar scanner status symbols

The radar scanner power mode status is indicated in the databar.

Symbol	Radar power mode	Description
	Transmit (TX)	Rotating icon, signifying that the scanner is on and transmitting. When SCANNER is set to ON, select this mode to activate the scanner. This is the usual mode of operation.
	Standby (STBY)	Static icon, indicating that the scanner is on but not transmitting, and the antenna is not rotating. The scanner does not transmit and the radar data is removed from the screen. This is a power-save mode used when the radar is not needed for short time periods. When you return to transmit mode, the magnetron does not need to warm up again. This is the default mode.
	Off	Scanner powered off when radar not required, but display is in use for other applications, such as the chart. When selected, the system counts down. During this time you cannot re-power the scanner.
	Timed Transmit	Scanner switches between on/transmitting, and standby mode. Scanner goes into power save mode when constant use of radar is not required.

AIS status symbols

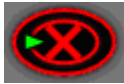

AIS status is indicated by a symbol in the databar.

Symbol	Description
	AIS unit is switched on and operating.
	AIS currently unavailable.
	AIS unit is switched off, or not connected.
	AIS unit is in Silent Mode.
	AIS unit is in Silent Mode, with active alarms.

Symbol	Description
	AIS unit is connected and switched on, but has active alarms.
	AIS unit is connected and switched on, but the dangerous and lost alarm is disabled.



Sonar status symbols

The sonar status is indicated in the databar.

Symbol	Description
	Symbol animated: the sonar module is connected and transmitting.
	Symbol static: the sonar module is connected but not transmitting.
	Symbol greyed-out: the sonar module is not connected, or is not detected.

GPS status symbols

The GPS receiver status is indicated in the databar.

Symbol	Description
	A GPS receiver is connected and has obtained a fix.
	A GPS receiver is not connected, or cannot obtain a fix.



6.7 Pages

Pages are made up of 1 to 4 panes that are used to display applications on your multifunction display (MFD).

Pages are accessed using the icons on the Homescreen.

- You can create up to 2 application panes per page using an MFD that has a screen size of 7 inches or less.
- You can create up to 4 application panes per page using an MFD that has a screen size of greater than 7 inches.
- MFDs with a screen size of 7 inches or less can view pages with more than 2 application panes but only if they are sharing the Homescreen of an MFD which is capable of creating those pages.

Pages can be customized, enabling you to group your applications into different pages, each designed for a specific purpose. For example, you could have a page that includes the chart and fishfinder applications, suitable for fishing, and another page that includes the chart and data applications, which would be suitable for general sailing.

	Icon for a page featuring a single application.
	Icon for a page featuring multiple applications.

You can also define the layout for each page, which determines how the applications are arranged on the screen.

Setting the Power-up page

You can setup your multifunction display to show a page instead of the Homescreen at power up.

Form the Homescreen:

1. Select **Customize**.
2. Select **Display Preferences**.
3. Select **Starting page**.

A list of options is displayed

- Homescreen — Homescreen is displayed after power-up.
- Last page — The page last viewed is displayed after power-up
- Choose page — The page you select will be displayed after power-up

- If selecting Choose page the Homescreen is displayed.



- Select the icon for the page you want displayed when the display is turned on.

The starting page setting applies to each individual display and is not automatically shared on networked displays.

Changing an existing page on the homescreen

With the homescreen displayed:

- Select **Customize**.
- Select **Homescreen**.
- Select **Edit Page**.
- Select the page icon that you want to change.
The Customize menu options are displayed.
- Select the appropriate page layout (for example, "Splitscreen").
- Select the application(s) you want to display on the page, either by selecting the relevant menu item or dragging it over to the displayed page.
- Select **Finish**.
The Rename Page dialog is displayed.
- Use the on-screen keyboard to name the page, then select **Save**.

Changing an empty page

With the homescreen displayed:

- Select **Customize**.
- Select **Homescreen**.
- Select **Edit Page**.
- Select an empty page icon (labelled "Customize").
The Customize menu options are displayed.
- Select the appropriate page layout (for example, "Splitscreen").
- Select the application(s) you want to display on the page, either by selecting the relevant menu item or dragging it over to the displayed page.
- Select **Finish**.
The Rename Page dialog is displayed.
- Use the on-screen keyboard to name the page, then select **Save**.

Moving a page on the homescreen

With the homescreen displayed:

- Select the **Customize** icon.

- Select **Homescreen**.
- Select **Swap Page**.
- Select the page icon that you want to move.
- Select the page icon that you want to swap positions with.
The page icon is moved to the new position.

Renaming a page on the homescreen

With the homescreen displayed:

- Select the **Customize** icon.
- Select **Homescreen**.
- Select **Rename Page**.
- Select the page that you want to rename.
The on-screen keyboard is displayed.
- Using the on-screen keyboard, enter the new name for the page.
- Select **SAVE**.

Deleting a page from the homescreen

With the homescreen displayed:









- Select the **Customize** icon.
- Select **Homescreen**.
- Select **Delete Page**.
- Select the page that you want to delete.
The page is deleted.

Resetting the homescreen to default settings

With the homescreen displayed:

- Select the **Customize** icon.
- Select **Homescreen**.
- Select **Reset**.
A warning message is displayed asking for confirmation.
- Select **Yes** to reset the homescreen to the default range of pages, or **No** to cancel the operation.

6.8 Applications

	<p>Chart application — provides a 2D or 3D graphical view of your charts to help you navigate. Waypoint, route, and track functions enable you to navigate to a specific location, build and navigate routes, or record where you've been. Chart cards provide higher levels of detail and 3D views.</p>
	<p>Fishfinder application — with a transducer and a sonar variant multifunction display or compatible Sonar Module, you can use the fishfinder application to help you accurately distinguish between different sizes of fish, bottom structure, and underwater obstacles. You can also view sea depth and temperature data and mark points of interest such as fishing spots or wrecks.</p>
	<p>Radar application — with a suitable radar scanner, you can use the radar application to track targets and measure distances and bearings. A number of automatic gain presets and color modes are provided to help you get the best performance from your radar scanner.</p>
	<p>Data application — view system and instrument data on your multifunction display, for a range of compatible instruments. Use the joystick or touchscreen to scroll through the available data pages.</p>
	<p>Weather application — (North America only). With a suitable weather receiver connected to your system, the weather application overlays historical, live, and forecasted weather graphics on a world map.</p>
	<p>Thermal cam application — view and control a thermal camera using a compatible multifunction display.</p> <div data-bbox="363 1552 786 1664" style="border: 1px solid black; padding: 5px;"> <p>Note: The thermal camera application is not available on a6x and a7x variant MFDs.</p> </div>
	<p>Camera application — view a video or camera source on your multifunction display.</p>
	<p>Doc Viewer — view pdf documents stored on a MicroSD card.</p>

	<p>FUSION Link application — link to and control a compatible Fusion entertainment system from your multifunction display.</p>
	<p>Sirius Audio application — control Sirius radio from your multifunction display.</p>
	<p>User Manual — Opens the English version of the product user manual stored on the display. To open translated user manuals stored on memory card use the Doc Viewer.</p>

6.9 Splitscreen controls

When viewing a page with more than 1 application displayed you can switch applications from the splitscreen view to fullscreen view.

Example 1 — Splitscreen page



Example 2 — Fishfinder application expanded to Fullscreen

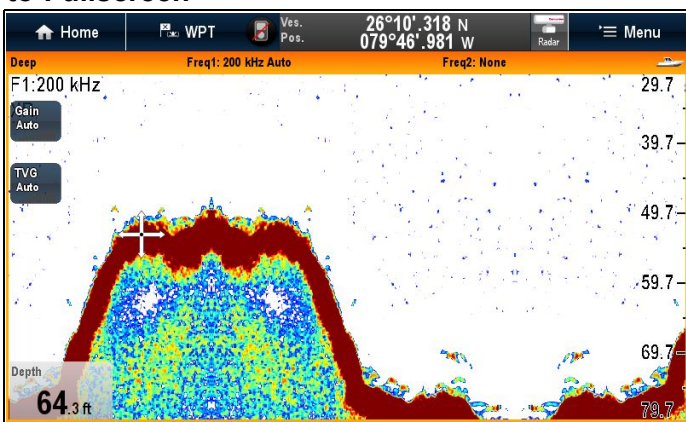

Selecting the active window

When viewing a splitscreen page you can select the active application and view it fullscreen by following the steps below.

With a page featuring multiple applications displayed:

1. Touch anywhere inside the application you want to make active.
A border appears around the application, indicating that it is active.
2. Select **Menu**.
3. Select **Fullscreen** to view the active application in fullscreen, or
4. Select **Splitscreen** to return to the splitscreen view.

Selecting the active window using Non-touch controls

When viewing a splitscreen page you can select the active application and view it fullscreen using the MFD's physical buttons or a remote keypad.

With a page featuring multiple applications displayed:

1. Press the  **Switch Active** button.
The active pane pop up is displayed:
2. Press the **Switch Active Pane** button or use the **Rotary control** to cycle the active application.

3. Use the **Range in** or **Range out** controls to switch the active application between splitscreen and fullscreen views.

Selecting the active window — e7 / e7D

When viewing a splitscreen page you can select the active application and view it fullscreen on an e7 / e7D with the touch lock enabled by following the steps below.

With a page featuring multiple applications displayed:

1. Press the **Menu** button.
2. Select **Cycle application**.
Selecting cycle application cycles through the available applications.
3. Select **Fullscreen** to view the active application in fullscreen, or
4. Select **Splitscreen** to return to the splitscreen view.

Switching the active pane or display using the keypad

The Switch Active button is used to switch the active pane on a multi application page and / or to switch the active display.

With multiple displays connected and / or multiple application page(s) displayed:

Cycle sequence

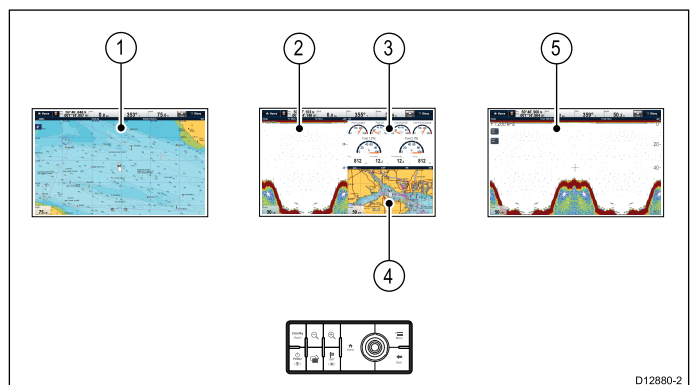

1. Press the **Switch Active** button to enter switch mode.
2. Use the **Rotary control** to cycle through the available panes and / or displays.

The keypad will cycle through displays in the order in which they were paired. On multi application pages the Range buttons can be used to switch the active application between full and splitscreen.

3. Press the **Back** button or the **Switch Active** button to exit switch mode.

6.10 Screen overview

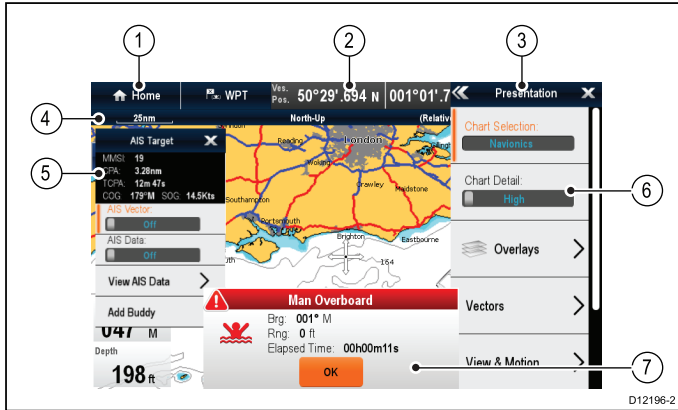

Screen item	Description
1	<p>Home</p> <ul style="list-style-type: none"> Displays with a touchscreen — Select the onscreen Home icon to access the Homescreen. Non-touchscreen and HybridTouch displays — Use the physical Home button to access the Homescreen.
2	<p>Databar — provides information about your vessel and its environment. The type of information in the databar can be customized from the Homescreen > Customize > Databar Set-up menu, if required.</p>
3	<p>Menu — menu options are specific to the application that you are currently using.</p>
4	<p>Status bar — provides information specific to each application. This information cannot be edited or moved.</p>
5	<p>Context menu — provides information and options specific to each application.</p>
6	<p>Menu options — menu options are displayed when the Menu is selected.</p>
7	<p>Pop-up messages — alert you to a situation (such as an alarm), or unavailable function. Pop-up messages may require a response from you — for example, select OK to silence alarms.</p>

Menus

Menus enable you to configure settings and preferences.

Menus are used in the:

- Homescreen** — to configure your multifunction display and externally-connected equipment.
- Applications** — to configure the settings for that particular application.



Screen item	Description
1	<p>Back — On displays with a touchscreen you can press the onscreen << (back) icon to go back to a previous menu. On non-touchscreen displays or HybridTouch displays use the Back button.</p>
2	<p>Close — On displays with a touchscreen you can press the onscreen X (close) icon to go back to a previous menu. On non-touchscreen displays or HybridTouch displays use the Back button to back out of the menu structure.</p>
3	<p>Selected menu option — the menu option currently selected will be highlighted.</p>
4	<p>Scroll bar — indicates that further menu items are available by scrolling the menu. On displays with a touchscreen to scroll through the available menu items, press and hold your finger on the menu and drag it up or down. On non-touchscreen displays or HybridTouch displays use the Rotary control.</p>
5	<p>On / Off switch — On displays with a touchscreen you can select onscreen menu items to switch features On or Off to enable or disable the function. On non-touchscreen displays or HybridTouch displays use the OK button to switch the function On or Off.</p>

Dialogs

Dialogs are fullscreen menus that enable you to manage data items such as waypoints and routes.

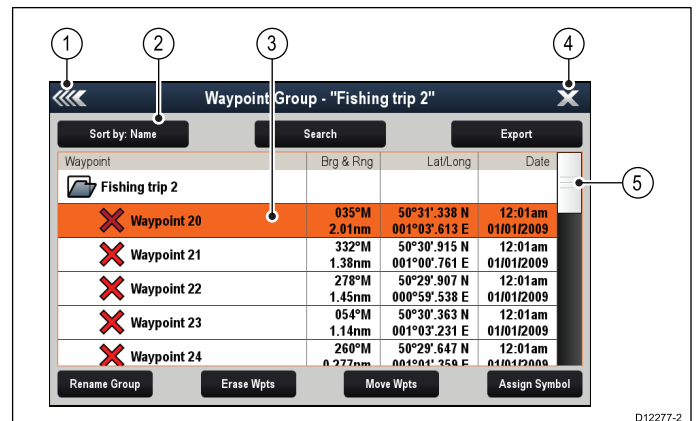

Screen item	Description
1	<p>Back</p> <ul style="list-style-type: none"> Displays with a touchscreen — Select the onscreen Back icon to go back to the previous menu. Non-touchscreen or HybridTouch displays — Use the Back button to go back to the previous menu.
2	<p>Function icons — Some dialogs include icons which can be selected to access additional functions. For example, in the Waypoint List dialog, the Sort by icon can be used to change how the waypoints list is sorted.</p>
3	<p>Menu / List item</p> <ul style="list-style-type: none"> Displays with a touchscreen — Momentarily touching an item automatically selects the item and displays the item options menu. Non-touchscreen or HybridTouch displays — Use the Rotary control to highlight an item, and the Ok button to select it and display the item options menu.
4	<p>Close</p> <ul style="list-style-type: none"> Displays with a touchscreen — Select the onscreen Close icon to close the dialog. Non-touchscreen or HybridTouch displays — Use the Back button to close the dialog.
5	<p>Scroll bar</p> <ul style="list-style-type: none"> Displays with a touchscreen — To scroll through the available items, press and hold your finger on the scroll bar and drag it up or down. Non-touchscreen or HybridTouch displays — To scroll through the available menu items, use the Rotary control.

1	Decrease display brightness
2	Increase display brightness
3	Power up / Power down Radar
4	Radar standby / Radar transmit
5	Autopilot standby (during active navigation)
6	Display pilot control dialog
7	PowerSave mode
8	Screenshot / Screen capture

Edit dialogs

Edit dialogs enable you to edit the details of data items stored on your multifunction display, such as waypoints, routes, and tracks.

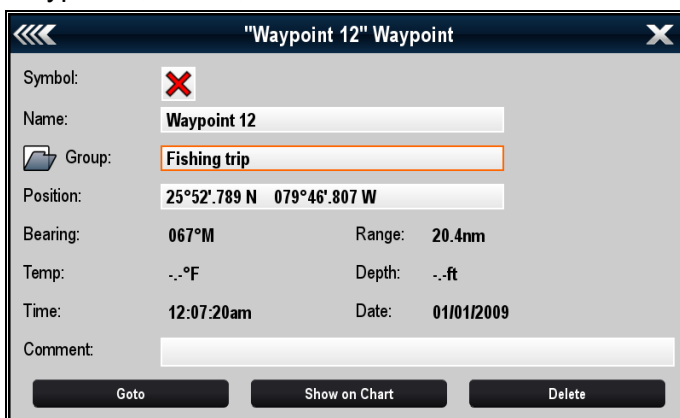

Selecting a text field displays the onscreen keyboard, which can be used to edit the details.

Editing information in dialogs

With the dialog displayed:

1. Select the field you want to edit.

The onscreen keyboard is displayed:



2. Use the onscreen keyboard to make the changes.
3. Select **SAVE** to save the changes.

Entering special or accented characters

With the onscreen keyboard displayed:

1. Select the onscreen keyboard's **àèò** key.
2. Select the character you want to accent.

The available accented characters are displayed above the text entry field.

3. For characters that have multiple available accents, use the character key to toggle between them.
4. Select the **àèò** key to enter the character.

Shortcuts page

A number of useful functions can be accessed from the Shortcuts page.

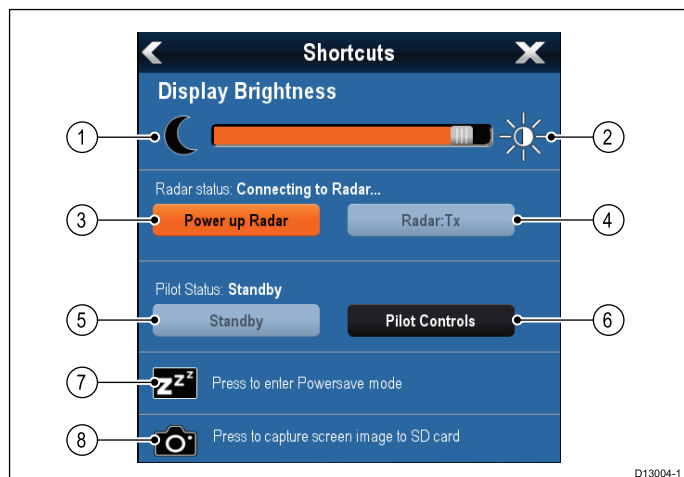

Numeric menu items

Numeric menu items display numeric data and enables you to either select a predefined value or to increase and decrease the value as required.



Editing numerical settings

To edit numerical values you can use either the onscreen numeric adjust control, onscreen numeric keypad or the **Rotary Control** on a non-touch or HybridTouch display to increase or decrease numeric values.



1. Select the numeric data field you want to edit. The numeric adjust control is displayed.
2. Adjust the setting to the required value using:
 - i. The **Rotary control** — Non-touchscreen or HybridTouch displays, or
 - ii. The onscreen **Up** and **Down** arrows — Touchscreen displays.
3. To access the on-screen numeric keypad:
 - Touch operation — Select the onscreen keypad icon from the numeric adjust control.
 - Non-Touch operation — Press and hold the **Ok** button.

The onscreen numeric keypad is displayed.

4. Enter the required value.
5. Select **Ok** to exit the numeric keypad and return to the menu.

Using slider bar controls

Slider bar controls provide a graphical representation of numeric data and enables you to quickly change setting values.

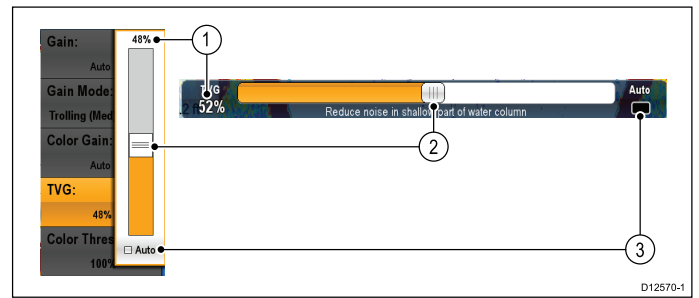

Item	Description	Non—Touch operation	Touch operation
1	Current value	N/A	N/A
2	Slider control	Use the Rotary control to adjust value	Slide the slider Up or Down to adjust value.
3	Auto	Press Ok button to switch between Auto and manual adjustment.	Select to switch between Auto and manual adjustment.

Using control dialogs

Control dialogs enable you to control externally connected equipment, such as an autopilot unit.

The following diagram shows the main features of a typical control dialog:

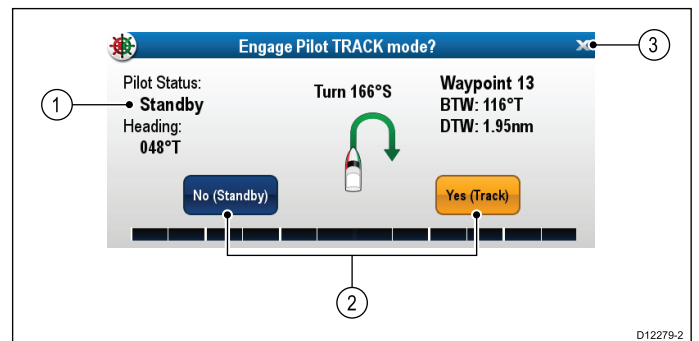

Screen item	Description
1	Status — provides status information for the connected equipment. For example, the Pilot Control dialog displays the locked heading and current navigation mode for a connected autopilot unit.
2	Control icons — provide direct control of the connected equipment. For example, the Pilot Control dialog Standby and Track icons enable you to instruct a connected autopilot unit to perform specific functions.
3	Close — Closes the control dialog.

6.11 Initial set up procedures

Once your display has been installed and commissioned, Raymarine recommends that you complete the Startup wizard and perform some additional procedures.

Startup wizard

When you power-up the display for the first time or after a system reset a Startup Wizard is displayed. The wizard guides you through the following basic configuration settings:

1. Language
2. Boat type
3. Configure Units (Units of measure)
4. Boat Details

Note: These settings can also be set at any time using the menus accessible from **Homescreen > Customize**.

Additional settings

In addition to the settings covered by the Wizard, it is also recommended that the following initial set up tasks are completed:

- Set your date and time preferences.
- Designate the data master.
- Select the GPS data source.
- Familiarize yourself with the product using Simulator Mode.



Warning: Minimum Safe Depth, Beam and Height

Depending on cartography vendor, the minimum safe settings are used during automatic route generation, they are used to restrict created routes from entering water that is not suitable for the vessel.

Data is taken from compatible cartography. Minimum safe settings are user defined calculations. As both of these factors are outside of Raymarine's control; Raymarine will not be held liable for any damage, physical or otherwise, resulting from the use of the automatic route generation feature or the **Minimum Safe Depth, Minimum Safe Beam or Minimum Safe Height** settings.

Minimum safe vessel depth

As part of the **Initial startup wizard** the **Minimum Safe Depth** value can be set.

Minimum Safe Depth can be established by adding together:

- Maximum Vessel Draft (i.e. the distance from the waterline to the lowest point of a vessel's keel.)
- Safety Margin (an adequate clearance below the keel to allow for draft variation and changes in water or bottom conditions.)

i.e.: **Minimum Safe Depth** = Maximum Vessel Draft + Safety Margin.

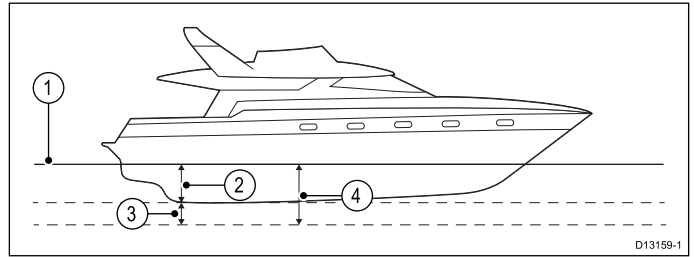

1. Waterline
2. Maximum Vessel Draft
3. Safety Margin
4. **Minimum Safe Depth**

Important: The information below is provided for guidance only and is not exhaustive. Some influencing factors can be unique to certain vessels and / or areas of water and may not be listed below. You should ensure you account for ALL factors that apply to your current situation when making calculations.

Some of the factors that can influence how much a vessel draws are shown below:

- **Vessel displacement (weight)** — A vessel's draft will increase when it is fully laden when compared with its unladen displacement.
- **Water type** — A vessel's draft will increase by approximately 2% to 3% in fresh water compared to seawater.

Some of the factors that should be taken into account when calculating a Safety Margin are:

- **Vessel maneuvering characteristics** — A vessel's draft increases due to squat, trim, roll, pitch and heave.
- **Chart accuracy** — The electronic chart depth may not be accurate or the true depth may have changed since the last survey.
- **Weather conditions** — High air pressure, and prevailing wind strength and direction can affect wave height.

Minimum safe beam

As part of the **Initial startup wizard** the **Minimum Safe Beam** value can be set. Minimum safe beam is required when using **Jeppesen® Easy Routing**.

Minimum Safe Beam can be established by adding together:

- Maximum Vessel Width (Beam)
- Safety Margin (an adequate clearance to either side of the vessel.)

i.e.: **Minimum Safe Beam** = Port Safety Margin + Beam + Starboard Safety Margin.

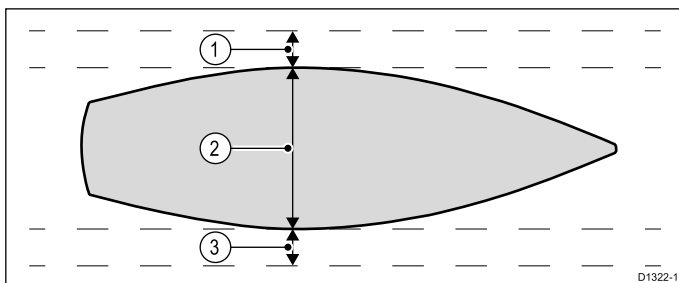

1. Port safety margin
2. Maximum Vessel Width (Beam)
3. Starboard safety margin

Important: The information below is provided for guidance only and is not exhaustive. Some influencing factors can be unique to certain vessels and / or areas of water and may not be listed below. You should ensure you account for ALL factors that apply to your current situation when making calculations.

Some of the factors that should be taken into account when calculating a Safety Margin are:

- **Vessel maneuvering characteristics** — A vessel's required clearance will increase due to roll.
- **Chart accuracy** — The electronic chart data may not be accurate or may have changed since last surveyed.

Minimum safe height

As part of the **Initial startup wizard** the **Minimum Safe Height** value can be set. Minimum safe height is required when using **Jeppesen® Easy Routing**.

Minimum Safe Height can be established by adding together:

- Maximum vessel height from waterline
- Safety Margin (an adequate clearance above the vessel to account for tide and weather effects.)

i.e.: **Minimum Safe Height** = Maximum Vessel Height + Safety Margin.

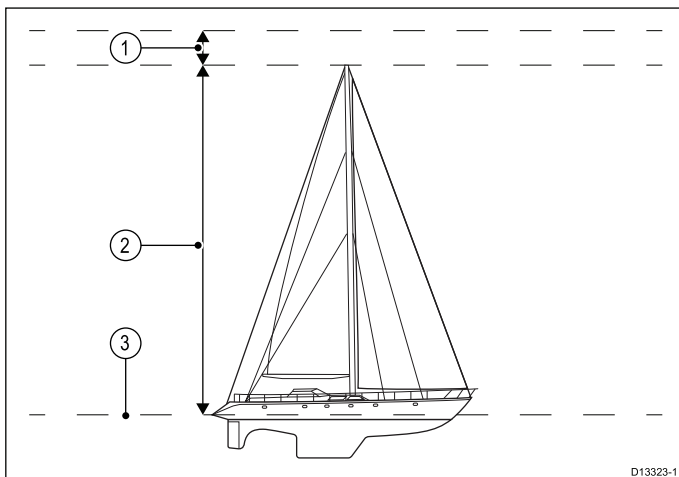

1. Safety Margin
2. Maximum height from waterline
3. Waterline

Important: The information below is provided for guidance only and is not exhaustive. Some influencing factors can be unique to certain vessels and / or areas of water and may not be listed below. You should ensure you account for ALL factors that apply to your current situation when making calculations.

Some of the factors that can influence vessel height are shown below:

- **Vessel displacement (weight)** — A vessel's height (from the waterline) will decrease when it is fully laden when compared with its unladen displacement.
- **Water type** — A vessel's height will decrease by approximately 2% to 3% in fresh water compared to seawater.

Some of the factors that should be taken into account when calculating a Safety Margin are:

- **Vessel maneuvering characteristics** — A vessel's height changes due to squat, trim, roll, pitch and heave.
- **Chart accuracy** — The electronic chart data may not be accurate or may have changed since the last survey.
- **Weather conditions** — Low air pressure, and prevailing wind strength and direction can affect water level.

Setting the vessel Minimum Safe Depth, Beam and Height

From the Homescreen:

1. Select **Customize**.
2. Select **Boat Details**.
3. Select **Min. Safe Depth, Min. Safe Beam** or **Min. Safe Height**.
4. Enter your calculated minimum safe settings.

Setting time and date preferences

With the homescreen displayed:

1. Select **Customize**.
2. Select **Time and Date Set-up**.
3. Use the **Date Format, Time Format, and Local Time: UTC** menu items to set your time and date preferences.

Data master

Any system containing more than one networked multifunction display must have a designated data master.

The data master is the display which serves as a primary source of data for all displays, it also handles all external sources of information. For example the displays may require heading information from the autopilot and GPS systems, usually received through a SeaTalk^{ng} or NMEA connection. The data master is the display to which the SeaTalk, NMEA and any other data connections are made, it then bridges the data to the SeaTalk^{hs} network and any compatible repeat displays. Information shared by the data master includes:

- Cartography
- Routes and waypoints
- Radar
- Sonar
- Data received from the autopilot, instruments, the engine and other external sources.

Your system may be wired for redundancy with data connections made to repeat displays. However these connections will only become active in the event of a fault and/or reassignment of the data master.

In an autopilot system which does not contain a dedicated pilot control head the Data master also acts as the control for the autopilot.

Designating the data master

For systems with 2 or more displays the following task must be performed on the multifunction display that you want to designate as the data master.

With the homescreen displayed:

1. Select **Set-up** .
2. Select **Maintenance**.
3. Select **Data Master**.
4. Select the display that you want to designate as the data master.

6.12 GNSS Status

The **GPS status** page enables you to view the status of the available satellites that are compatible with your receiver.

The satellite constellations are used to position your vessel in the Chart and Weather applications. You can set up your receiver and check its status from the GPS Set-up menu: **Homescreen > Set-up > System Settings > GPS Set-up**. For each satellite, the screen provides the following information:

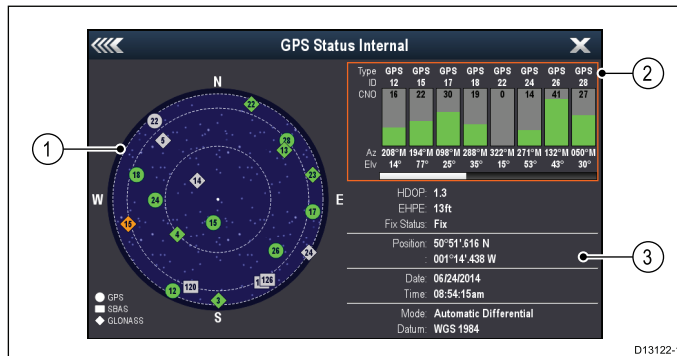

1. Sky view
2. Satellite status
3. Position and fix information

Sky view

Sky view is a visual representation that shows the position of navigation satellites and their type. Satellite types are:

- **Circle** — A circle identifies a satellite from the GPS constellation.
- *** Diamond** — A diamond identifies a satellite from the GLONASS constellation.
- **Square** — A square identifies an (SBAS) differential satellite.

Note: GLONASS satellites are only available when connected to a compatible GNSS receiver such as the built-in receiver Refer to the *Technical specification* for your product to identify your **MFD's** receiver type.

Satellite status area

The Satellite status area displays the following information about each satellite:

- **Type** — Identifies which constellation the satellite belongs to.
- **ID** — Displays the satellites identification number.
- **CNO** (Carrier-to-noise ratio) — Displays the signal strength of each satellite shown in the Sky view:
 - Grey = searching for satellite
 - Green = satellite in use
 - Orange = tracking satellite
- **Azimuth and Elevation** — Provides the angle of elevation and azimuth between the location of the receiver and the satellite.

Position and fix information

The following positional and fix information is provided:

- **Horizontal Dilution of Precision (HDOP)** — HDOP is a measure of satellite navigation accuracy, calculated from a number of factors including satellite geometry, system errors in the data transmission and system errors in the receiver. A higher figure signifies a greater positional error. A typical receiver has an accuracy of between 5 and 15 m. As an example, assuming a receiver error of 5 m, an HDOP of 2 would represent an error of approximately 15 m. Please remember that even a very low HDOP figure is NO guarantee that your receiver is providing an accurate position. If in doubt, check the displayed vessel position in the Chart application against your actual proximity to a known charted object.
- **Estimated Horizontal Position Error (EHPE)** — EHPE is a measure of the estimated error of a position fix in the horizontal plane. The value displayed indicates that your position is within a circle radius of the stated size 50% of the time.
- **Fix status** — indicates the actual mode the receiver is reporting:
 - **Fix** — Satellite fix has been acquired.
 - **No Fix** — No satellite fix can be acquired.
 - **D Fix** — A differential beacon fix has been acquired.
 - **SD Fix** — A differential satellite fix has been acquired.
- **Position** — Displays the latitude and longitude position of your receiver.
- **Date / Time** — Displays the current date and time generated by the position fix in UTC format .
- **Mode** — Identifies whether the receiver is working in differential mode or non-differential mode.
- **Datum** — The receiver's datum setting affects the accuracy of the vessel position information displayed in the Chart application. In order for your receiver and MFD to correlate accurately with your paper charts, they must be using the same datum.

Global Navigation Satellite Systems (GNSS)

A GNSS is a system of satellites that provides autonomous geo-spatial positioning that allows electronic devices with compatible receivers to determine their location (longitude, latitude and altitude).

Operational GNSS

- **GPS (NAVSTAR) Global Positioning System**
US owned constellation of satellites that became fully operational in 1995.
- **GLONASS** acronym for "**GL**Obalnaya **NA**avigatsionnaya **S**putnikovaya **S**istema" or "Global Navigation Satellite Systems"
Russian owned constellation of satellites that offered global coverage in 2010.

Planned GNSS

- **Galileo**
European satellite constellation in initial deployment phase due to become operational in 2020.

- **COMPASS / Beidou-2**
Chinese Regional Navigation Satellite System (Beidou) is currently being expanded for global coverage (COMPASS or Beidou-2) by 2020.

Satellite based augmentation systems (SBAS)

Satellite based augmentation systems (SBAS) are systems that are used to compliment existing GNSS by providing differential corrections that improve a GNSS's attributes such as accuracy, availability and reliability.

The image below shows SBAS regional coverage.

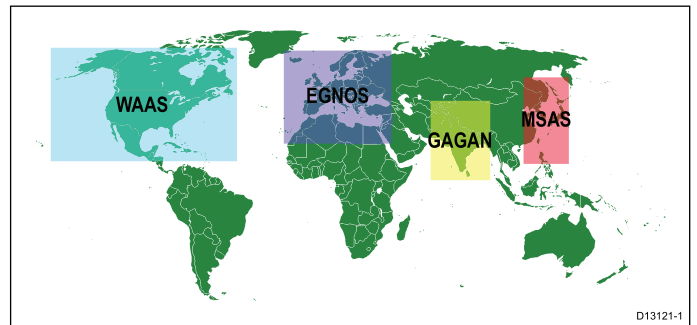

- **WAAS** — Wide Area Augmentation System (Operated by the Federal Aviation Authority (FAA) in the USA.)
- **EGNOS** — European Geostationary Navigation Overlay Service (Operated by the European Space Agency.)
- **GAGAN** — GPS Aided Geo Augmented Navigation (Operated by India.)
- **MSAS** — Multi-functional Satellite Augmentation System (Operated by Japan's Ministry of Land, Infrastructure and Transport and Japan Civil Aviation Bureau (JCAB))
- **QZSS** — Quasi-Zenith Satellite System (Proposed by Japan)

Raymarine GPS / GNSS receiver compatibility

Raymarine GPS receivers and GNSS (GPS/GLONASS) receivers are compatible with the following GNSS and SBAS.

Status / Type	Name	Compatible receivers
Operational GNSS	GPS	All internal and external Raymarine GPS receivers and GNSS receivers
Operational GNSS	GLONASS	a9x and a12x internal GNSS receiver
Planned GNSS	COMPASS / Beidou-2	* a9x and a12x internal GNSS receiver
Planned GNSS	Galileo	* a9x and a12x internal GNSS receiver
Operational SBAS	WAAS	All internal and external Raymarine GPS receivers and GNSS receivers

Status / Type	Name	Compatible receivers
Operational SBAS	EGNOS	All internal and external Raymarine GPS receivers and GNSS receivers
Operational SBAS	MSAS	All internal and external Raymarine GPS receivers and GNSS receivers
Operational SBAS	GAGAN	All internal and external Raymarine GPS receivers and GNSS receivers
Planned SBAS	QZSS	* a9x and a12x internal GNSS receiver

Note: * Not currently operational but will be supported via software update in the future.

GPS selection

You can use an internal (if available) or external GPS receiver or GNSS receiver.

- Your multifunction display may feature an internal GPS or GNSS receiver.
- You can also connect an external receiver using SeaTalk^{ng} or NMEA 0183.
- Where appropriate use the System Settings menu to enable or disable the internal receiver.

Enabling or disabling the internal receiver

If your multifunction display features an internal GPS receiver or GNSS receiver then this can be enabled and disabled by following the steps below.

With the Homescreen displayed:

1. Select **Set-Up**.
2. Select **System Settings**.
3. To enable the internal receiver, select **Internal GPS** so that On is highlighted.
4. To disable the internal receiver, select **Internal GPS** so that Off is highlighted.

Enabling and disabling differential satellites

You can choose whether or not your receiver uses differential data provided by SBAS constellations.

From the GPS Set-up menu: **Homescreen > Set-up > System Settings > GPS Set-up:**

1. Select **Differential GPS**.
Selecting Differential GPS will switch differential satellite (SBAS) reception On (default) and Off.

Choosing differential satellites

You can select which constellations of SBAS your receiver will use.

From the GPS Set-up menu: **Homescreen > Set-up > System Settings > GPS Set-up:**

1. Select **Differential System**
The following differential systems are available:
 - WAAS

- EGNOS
- MSAS
- GAGAN
- All Others

2. Select the relevant differential system from the menu to switch reception for that system On (default) and Off.

COG/SOG Filter

The COG/SOG filter averages the velocity vectors to compensate for the oscillating motion of the vessel, giving a clearer indication of the vessel's course and speed.

The filter does not affect the calculation of your receiver's reported position. The velocity vectors calculated from the signal provide an instantaneous measure of speed and direction of the receiver. The COG and SOG can therefore seem erratic under certain conditions. For example, when a vessel is moving slowly through rough seas, the receiver moves from side to side as well as in the direction of travel.

Slow moving vessels, or vessels sailing in rough seas will benefit from a high setting, whereas a power boat that can quickly change speed and direction will benefit from a low setting.

Selecting COG/SOG filter

You can change the level of filter applied to COG/SOG.

From the GPS Set-up menu: **Homescreen > Set-up > System Settings > GPS Set-up:**

1. Select **COG/SOG Filter**.
A list of available filter levels is displayed:
 - Low
 - Medium (default)
 - High
2. Select the required filter level from the list.

Restarting the GNSS (GPS/GLONASS) receiver

To restart the GNSS (GPS/GLONASS) receiver follow the steps below:

From the GPS Set-up menu: **Homescreen > Set-up > System Settings > GPS Set-up:**

1. Select **Restart GPS**.
The receiver will be restarted.

6.13 Enabling autopilot control

Enabling the autopilot control function — SeaTalk and SPX SeaTalk^{ng} autopilots

To enable control of your SeaTalk or SPX SeaTalk^{ng} autopilot using your multifunction display follow the steps below.

From the Homescreen:

1. Select **Set-up**.
2. Select **System Settings**.
3. Select **Autopilot Control** so that On is highlighted.
Selecting Autopilot Control will switch the control between On and Off.

On a system containing multiple displays the pilot control is enabled on all displays at the same time.

Enabling the autopilot control function — Evolution autopilots

To enable control of your Evolution autopilot using your multifunction display follow the steps below.

From the Homescreen.

1. Select **Set-up**.
2. Select **System Settings**.
3. Select **External Devices**.
4. Select **Pilot Set-up**.
5. Select **Pilot control** so that On is highlighted.
Selecting Pilot control will switch the Autopilot control function on and off.

6.14 Engine identification

Engine data can be displayed on your MFD using the Data application, which provides some preset Engine pages for displaying some of the most common types of engine data.

Important: Before you can display Engine data on your MFD, you must:

- Ensure that your MFD is running LightHouse software version 8 or later.
- **Refer to the important “Engine setup with an ECI interface” and “Using the engine identification wizard” information.**
- Make the data connections, according to the instructions provided in the **87202 ECI Installation instructions**.
- Ensure all data buses are powered up (including engine data CAN buses, gateways, and also the SeaTalk^{ng} bus).
- Start the engine. It is important that only one engine is running at a time, to ensure that the system can isolate the correct engine data message.
- Run the **Engine identification wizard** to ensure that your engines are displayed in the correct order in the Data application.



Engine setup with an ECI interface

Before you can display engine data on your MFD, you may need to use the "Engine Identification wizard" on the MFD to setup the engines.

Important: When setting up on a multiple engine system, engines should always be turned on in sequence from port to starboard.

The following table details the different types of engine supported by the ECI interface unit, and the setup requirements for each:

Engine CAN bus protocol	Number of engines	Engine CAN bus configuration	Number of ECI units	Setup via wizard on MFD required
NMEA 2000	1	Single CAN bus	1	✗
NMEA 2000	2+	Single shared CAN bus	1	✗
NMEA 2000	2+	Separate CAN bus for each engine	1 for each CAN bus	✓
J1939	1	Single CAN bus	1	✗
J1939	2+	Single shared CAN bus	1	✗
J1939	2+	Separate CAN bus for each engine	1 for each CAN bus	✓

Engine interfacing without an ECI unit

For engines with a NMEA 2000 CAN bus it may be possible to connect to a Raymarine MFD via a SeaTalk^{ng} system without the use of a Raymarine ECI unit.

Refer to your engine dealer and also your local Raymarine dealer for advice on any engine instancing requirements and suitable connection cables.

Using the engine identification wizard

If your engine data appears in the wrong order on the engine data pages you can correct this by running the engine identification wizard.

From the Homescreen:

1. Select **Set-up > System Settings > External Devices > Engines Set-up**.
2. If required change the number of engines your vessel has by selecting **Num. of Engines:** and entering the correct number of engines.

You can select up to 5 engines.

3. Select **Identify engines**.

Important: It is important that only one engine is running at a time, to ensure that the system can isolate the correct engine data message.

4. Follow the onscreen prompts to complete the engine identification wizard.

The engines that will be included in the identification wizard are determined by the Number of engines set during step 2 above.

- i. Switch Off ALL vessel engines and select **Next**.

The wizard will run through all engines (max of 5 as defined in step 2 above) from port to starboard in sequence.

- ii. Turn On the **port engine** and select **OK**.
The wizard will now listen for data and assign the engine instance as the port engine.
 - iii. Turn On the **center port engine** and select **OK**.
The wizard will now listen for data and assign the engine instance as the center port engine.
 - iv. Turn On the **center engine** and select **OK**.
The wizard will now listen for data and assign the engine instance as the center engine.
 - v. Turn On the **center starboard engine** and select **OK**.
The wizard will now listen for data and assign the engine instance as the center starboard engine.
 - vi. Turn On the **starboard engine** and select **OK**.
The wizard will now listen for data and assign the engine instance as the starboard engine.
5. Select **OK** on the Identify Engines confirmation dialog.

The engines will now appear in the correct location on the engine data page.

6.15 Enabling AIS functions

Before proceeding ensure your AIS unit is connected to NMEA Port 1.

With the homescreen displayed:

1. Select **Set-Up**.
2. Select **System Settings**.
3. Select **NMEA Set-Up**.
4. Select **NMEA Input Port 1**.
5. Select the AIS 38400 option.
6. Select **Back** to return to the **System Settings** menu.
7. Select **External Devices**.
8. Select **AIS Unit Set-up**.

The AIS Unit Set-up menu is displayed.

9. Adjust the AIS options as appropriate.

6.16 Shared preferences

The Shared preferences scheme allows all compatible networked **MFDs** and instrument displays to share user preference settings. When a user preference is changed on 1 display device all compatible networked display devices are automatically updated to use the changed preference.

Shared preferences are applicable to the following devices:

- **MFDs** networked using **SeaTalk^{hs}**
- **MFDs** networked using **SeaTalk^{ng}**
- **SeaTalk^{ng}** instruments displays networked using **SeaTalk^{ng}**
- **SeaTalk** instruments displays networked via a **SeaTalk** to **SeaTalk^{ng}** converter.

Note: To ensure compatibility check that all devices are running the latest software versions. Check the **Raymarine[®]** website www.raymarine.com for the latest software for your products.

List of shared preferences

The table below shows the settings that are shared as part of the Shared preference scheme.

Units

- Speed units
- Distance units
- Depth units
- Wind units
- Temperature units
- Flow Rate units
- Volume Units
- Pressure units

Boat Details

- Boat Type
- Number of engines
- Number of fuel tanks
- Number of batteries

Time and Date

- Date Format
- Time Format
- Local Time (UTC) offset

System Preferences

- Bearing mode
- Variation (manual)
- Language

Data application

- Max RPM range
- RPM red zone
- RPM red zone value

6.17 Memory cards and chart cards

MicroSD memory cards can be used to back up / archive data (e.g. Waypoint, and Tracks). Once data is backed up to a memory card old data can be deleted from the system, creating capacity for new data. The archived data can be retrieved at any time. Chart cards provide additional or upgraded cartography.

It is recommended that your data is backed up to a memory card on a regular basis. Do NOT save data to a memory card containing cartography.

Compatible cards

The following types of MicroSD cards are compatible with your display:

- Micro Secure Digital Standard-Capacity (MicroSDSC)
- Micro Secure Digital High-Capacity (MicroSDHC)

Note:

- The maximum supported memory card capacity is 32 GB.
- MicroSD cards must be formatted to use either the FAT or FAT 32 file system format to enable use with your MFD.

Speed class rating

For best performance it is recommended that you use Class 10 or UHS (Ultra High Speed) class memory cards.

Chart cards

Your product is pre-loaded with electronic charts (worldwide base map). If you wish to use different chart data, you can insert compatible chart cards into the unit's memory card reader.

Use branded chart cards and memory cards

When archiving data or creating an electronic chart card, Raymarine recommends the use of quality branded memory cards. Some brands of memory card may not work in your unit. Please contact customer support for a list of recommended cards.

6.18 Simulator mode

The Simulator mode enables you to practice operating your display without data from a GPS antenna, radar scanner, AIS unit, or fishfinder.

The simulator mode is switched on / off in the **System Setup Menu**.

Note: Raymarine recommends that you do NOT use the simulator mode whilst navigating.

Note: The simulator will NOT display any real data, including any safety messages (such as those received from AIS units).

Note: Any system settings made whilst in Simulator mode are NOT transmitted to other equipment.

Enabling and disabling simulator mode

You can enable and disable simulator mode by following the steps below.

With the homescreen displayed:

1. Select **Set-Up** .
2. Select **System Settings**.
3. Select **Simulator**:
4. Select On to turn simulator mode on, or
5. Select Off to turn simulator mode off.

Note: The Demo movie option is for retail demonstration purposes only.

6.19 Pairing the keypad

The keypad can control 1 or more multifunction displays. Multiple keypads can be connected to a system. Each keypad can be paired with up to 4 multifunction displays.

With the keypad connected to the multifunction display:

1. Select **External Keypad** from the External Devices menu: **homescreen > Set-up > System Settings > External Devices > External Keypad**.
2. Select **Pair Keypad**.
3. Press any button on the external keypad.
4. From the pop-up message select the orientation of the keypad.

Either landscape or portrait orientations are available.

The keypad is now paired.

Unpairing the keypad

The keypad can be unpaired from an individual display.

1. Select **External Keypad** from the External Devices menu: **homescreen > Set-up > System Settings > External Devices > External Keypad**.
2. Select **Clear Pairings**.
3. Select **Yes** to unpair the keypad with the display.

6.20 System software updates

Raymarine regularly issues software updates for its products that can provide new and enhanced features and improved performance and usability. You should ensure that you have the latest software for your products by regularly checking the **Raymarine®** website for new software. **Raymarine®** MFDs can be used to check and update the software of compatible **Raymarine®** products.

You can identify product software versions using the Diagnostics page on your **MFD: Homescreen > Set-up > Maintenance > Diagnostics > Select Device**.

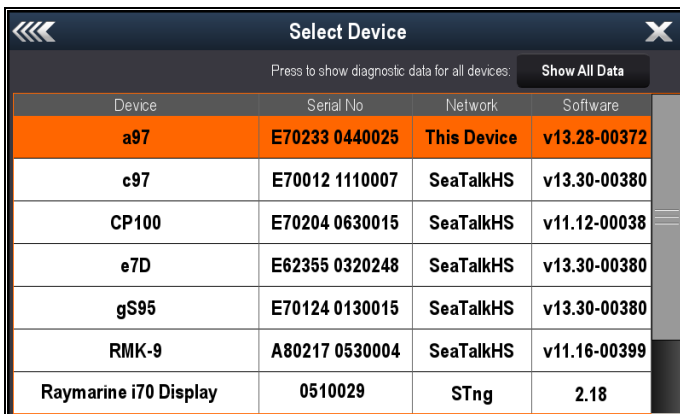

Device	Serial No	Network	Software
a97	E70233 0440025	This Device	v13.28-00372
c97	E70012 1110007	SeaTalkHS	v13.30-00380
CP100	E70204 0630015	SeaTalkHS	v11.12-00038
e7D	E62355 0320248	SeaTalkHS	v13.30-00380
gS95	E70124 0130015	SeaTalkHS	v13.30-00380
RMK-9	A80217 0530004	SeaTalkHS	v11.16-00399
Raymarine i70 Display	0510029	STng	2.18

The system update process can be used to update all compatible products connected over **SeaTalk^{hs}** and **SeaTalk^{ng}®**.

Please refer to the **Software Update** section of the **Raymarine®** website www.raymarine.com/software for details of compatible products.

Caution: Downloading software updates

The software update process is carried out at your own risk. Before initiating the update process ensure you have backed up any important files.

Ensure that the unit has a reliable power supply and that the update process is not interrupted.

Damage caused by incomplete updates are not covered by Raymarine warranty.

By downloading the software update package, you agree to these terms.

Downloading software updates

Software updates can be downloaded from the Raymarine website.

To perform a software update you will need:

- A PC or Apple Mac with an internet connection and a card reader.
- A FAT 32 formatted MicroSD card with SD card adaptor.

Note: Do not use a cartography chart card for software updates or user data / settings backups.

1. Go to the Software update section of the **Raymarine®** website www.raymarine.com/software

- Compare the latest available software against the software version of your **Raymarine®** products.
 - If the software on the website is newer than the software on your products download the relevant software package.
 - Insert the MicroSD card into your PC or Mac card reader.
- Depending on your computers card reader type an SD card adaptor may be required.
- Unzip the downloaded software package 'zip' file to the MicroSD card.
 - If used, remove the MicroSD card from the SD card adaptor.

Performing software updates

Attention Do NOT perform software updates whilst your boat is underway.

- Backup your user data and settings.
- Insert the MicroSD card containing software update files into the card reader of your **Data Master MFD**.
If the inserted card contains updated software for a device on your system, after a few seconds a pop-up message is displayed. If you need to re-install or downgrade software then select the **Check Card for Updates** option from the **Maintenance** menu: **Homescreen > Set-up > Maintenance**.
- Select **Yes**.
A second pop-up is displayed.
- Select **Ok**.
The Software updates page is displayed.

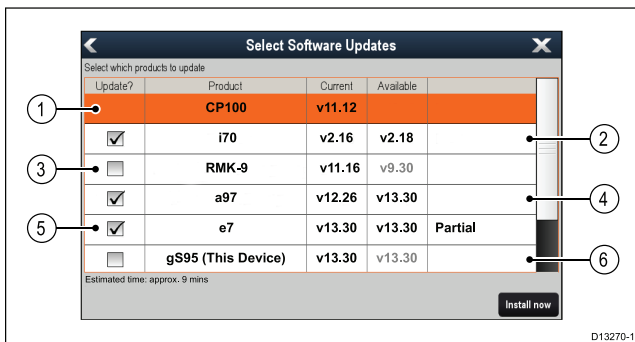

1	No software update available on memory card
2	Software update available on memory card
3	Software on memory card is older than the software installed on the product
4	Software update available on memory card
5	Partial software update available on memory card
6	Software version on memory card is the same as the software installed on the product

If a software update is available on the memory card the **Update?** box is automatically ticked.

- On touchscreen displays you can select and hold on the available software version to see further details about the software that will be installed.

- Select the products that you want to update.

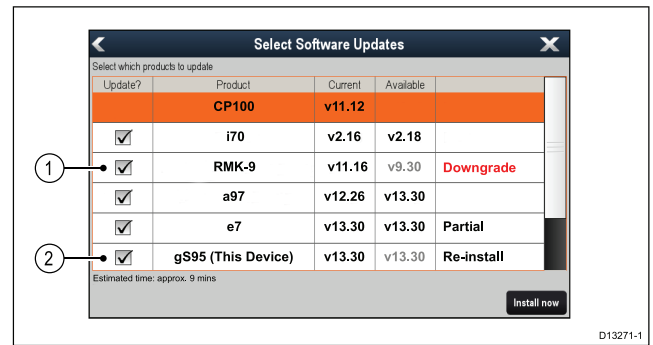

1	Software downgrade will be performed
2	The same software version will be re-installed

- Select **Install Now**.

The installation process will begin.

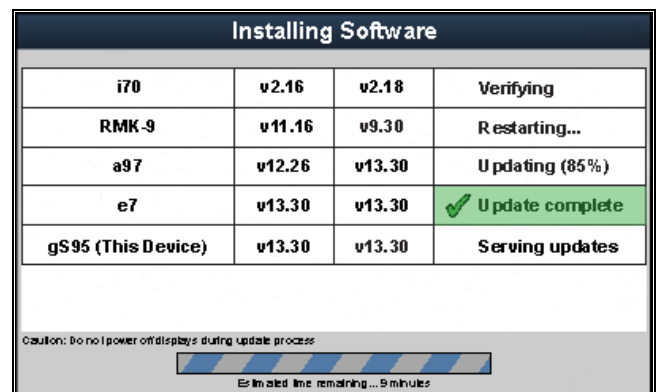

During the update process details of each products progress is displayed. The **MFD** serving the software updates will be the last device to be update.

- Select **Ok** on the Software Updates pop-up message.
- Remove the MicroSD card from the card reader.

Note: Turning on a display whilst it has a memory card inserted that contains software update files saved to the root directory will start a standalone software update on that display only.

6.21 Learning resources

Raymarine has produced a range of learning resources to help you get the most out of your products.

Video tutorials

	<p>Raymarine official channel on YouTube:</p> <ul style="list-style-type: none">• http://www.youtube.com/user/RaymarineInc
	<p>Video Gallery:</p> <ul style="list-style-type: none">• http://www.raymarine.co.uk/view/?id=2679
	<p>Product Support videos:</p> <ul style="list-style-type: none">• http://www.raymarine.co.uk/view/?id=4952

Note:

- Viewing the videos requires a device with an Internet connection.
- Some videos are only available in English.

Training courses

Raymarine regularly runs a range of in-depth training courses to help you make the most of your products. Visit the Training section of the Raymarine website for more information:

- <http://www.raymarine.co.uk/view/?id=2372>

FAQs and Knowledge Base

Raymarine has produced an extensive set of FAQs and a Knowledge Base to help you find more information and troubleshoot any issues.

- <http://www.raymarine.co.uk/knowledgebase/>

Technical support forum

You can use the Technical support forum to ask a technical question about a Raymarine product or to find out how other customers are using their Raymarine equipment. The resource is regularly updated with contributions from Raymarine customers and staff:

- <http://raymarine.ning.com/>

Chapter 7: System checks

Chapter contents

- [7.1 GPS Check on page 88](#)
- [7.2 Radar check on page 88](#)
- [7.3 Sonar check on page 89](#)
- [7.4 Thermal camera setup and checks on page 91](#)

7.1 GPS Check

Checking GPS operation

You can check that the GPS is functioning correctly using the chart application.

1. Select the Chart page.

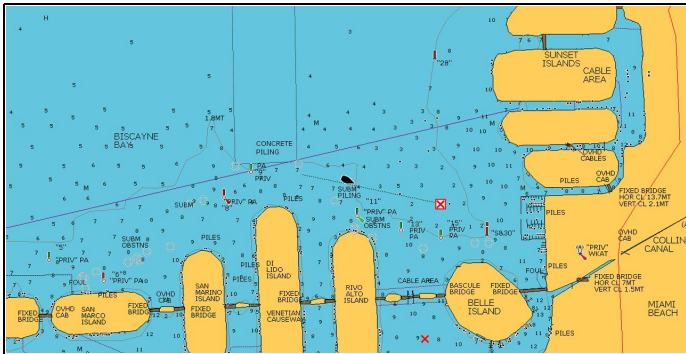

2. Check the screen.

With the chart displayed, you should see:

Your boat position (indicates a GPS fix). Your current position is represented by a boat symbol or solid circle. Your position is also displayed in the data bar under VES POS.

A solid circle on the chart indicates that neither heading nor Course Over Ground (COG) data is available.

Note: Raymarine recommends that you check the displayed vessel position in the chart application against your actual proximity to a known charted object. GPS receivers typically have an accuracy of between 5 and 15 m.

Note: A GPS Status screen is available within the Setup menu of Raymarine multifunction displays. This provides satellite signal strength and other relevant information.

7.2 Radar check



Warning: Radar scanner safety

Before rotating the radar scanner, ensure all personnel are clear.



Warning: Radar transmission safety

The radar scanner transmits electromagnetic energy. Ensure all personnel are clear of the scanner when the radar is transmitting.

Checking the radar

From the Radar application:

1. Select **Menu**.
2. Select **Power** so that On is highlighted.
The Radar scanner will now initialize in standby mode. This process will take approximately 70 seconds.
3. Select **Radar** so that Transmit is highlighted.
The radar scanner should now be transmitting and receiving.
4. Check that the radar screen is operating correctly.

Typical HD radar screen

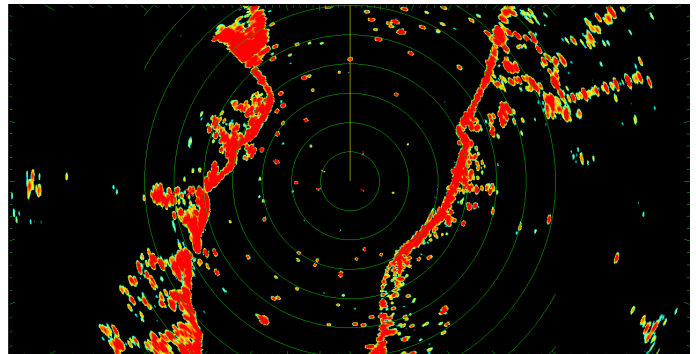

Note: The example above is representative of the enhanced output provided by a HD radar scanner.

Points to check:

- Radar sweep with echo responses are shown on screen.
- Radar status icon rotating in top right hand corner of the status bar.

Check and adjust bearing alignment

Bearing alignment

The radar bearing alignment ensures that radar objects appear at the correct bearing relative to your boat's bow. You should check the bearing alignment for any new installation.

Example misaligned radar

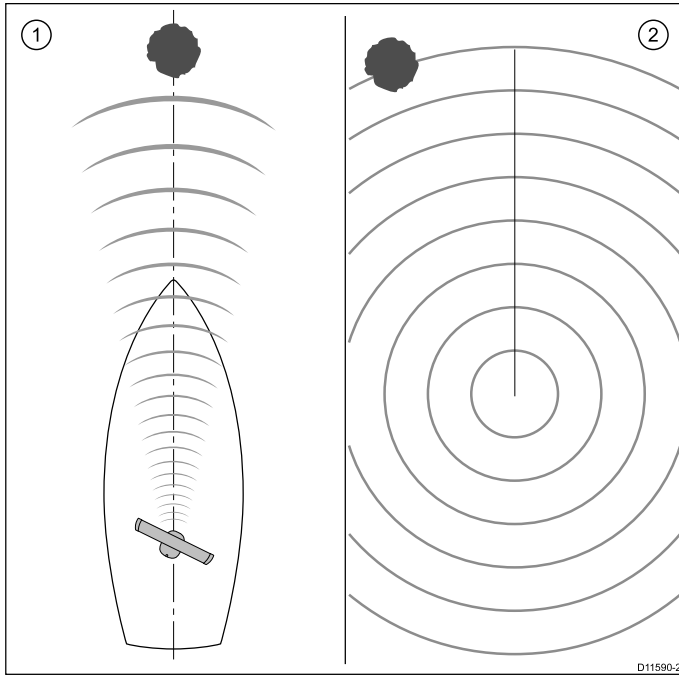

Item	Description
1	Target object (such as a buoy) dead ahead.
2	Target displayed on the radar display is not aligned with the Ship's Heading Marker (SHM). Bearing alignment is required.

Checking the bearing alignment

1. With your vessel under way: Align the bow with a stationary object identified on the radar display. An object between 1 & 2 NM distant is ideal.
2. Note the position of the object on the radar display. If the target is not under the ship's heading marker (SHM), there is an alignment error and you will need to carry out bearing alignment adjustment.

Adjusting the bearing alignment

Once you have checked the bearing alignment you can proceed and make any required adjustments.

With the radar application displayed:

1. Select **Menu**.
2. Select **Radar Set-up**.
3. Select **Advanced**.
4. Select **Bearing Alignment**.
Selecting Bearing Alignment displays the numeric adjust control.
5. Adjust the setting so that the selected target is under the Ship's Heading Marker.
6. Select **Back** or **Ok** when complete.

7.3 Sonar check

Sonar transducer and sonar module selection

You must select the sonar transducer and Sonar module that you want to use in the displayed Fishfinder application pane.

Sonar module selection

- Sonar and DownVision™ variant displays are fitted with an internal sonar module.
- All variants allow you to connect a compatible external sonar module or use an internal sonar module from a networked display.
- The sonar channel you want to use must be selected from the Fishfinder menu.

Transducer selection

- Sonar variant displays allow direct connection of a Raymarine OR a Minn Kota sonar transducer.
- DownVision™ variant displays allow direct connection of Raymarine DownVision™ transducers.
- All variants allow the connection of a Raymarine sonar transducer via a compatible external sonar module.
- For all variants use the **Transducer Set-Up** menu in the Fishfinder application to specify the transducer you want to use.

Selecting the sonar channel

To select the channel you want to display follow the steps below.

From the Fishfinder application:

1. Select **Menu**.
2. Select **Channel**.
The Channel selection page is displayed.
3. Select the tab for the sonar module you want to use.
A list of available channels for the selected sonar module is displayed.
4. Select a channel from the list.

The Channel selection page will close and the Fishfinder application will now show the selected channel.

Selecting the sonar transducer

With the fishfinder application displayed:

1. Select **Menu**.
2. Select **Set-Up**.
3. Select **Transducer Set-Up**.
4. Select **Transducer**.
A list of transducers is displayed.
5. Select the transducer you want to use.

Selecting the speed transducer

With the fishfinder application displayed:

1. Select **Menu**.
2. Select **Set-Up**.
3. Select **Transducer Set-Up**.

4. Select **Speed Transducer**.

A list of transducers is displayed.

5. Select your speed transducer from the list.

Checking the sonar

Sonar checks are made using the fishfinder application.

1. Select a fishfinder page from the Homescreen.

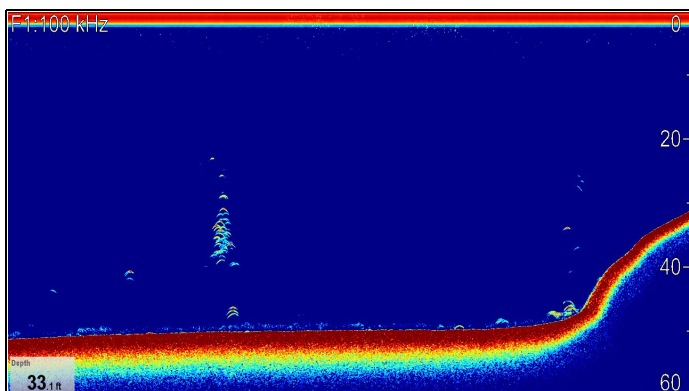

2. Check the fishfinder display.

With the fishfinder active you should see:

- Depth reading (indicates the transducer is working). The depth is shown in a databox in the bottom left of the screen.

If the databox is not present it can be turned on from the Presentation menu: **Menu > Presentation > Databoxes Set-up**.

Fishfinder Transducer Calibration

Your fishfinder transducer must be calibrated correctly to achieve accurate depth readings.

The multifunction display receives the image from a sonar module which processes sonar signals from a transducer mounted in the water. If the transducer is equipped with a speed paddle wheel and temperature-sensing thermistor, the sonar module calculates speed and temperature. To ensure accurate readings, it may be necessary to calibrate the transducer(s) by applying offsets to depth, speed and temperature. As these settings are held in the sonar module and relate to the transducer, they are applied system-wide.

Depth Offset

Depths are measured from the transducer to the sea bed, but you can apply an offset value to the depth data, so that the displayed depth reading represents the depth to the sea bed from either the keel or the waterline.

Before attempting to set a waterline or keel offset, find out the vertical separation between the transducer and either the waterline or the bottom of the keel on your vessel, as appropriate. Then set the appropriate depth offset value.

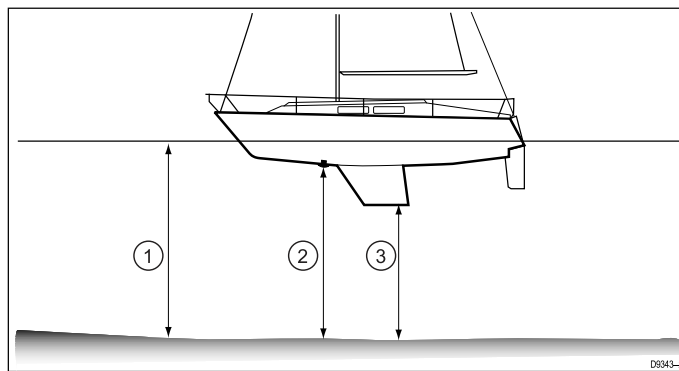

1	Waterline offset
2	Transducer / Zero offset
3	Keel offset

If an offset is not applied, displayed depth readings represent the distance from the transducer to the sea bed.

Setting the depth offset

From the fishfinder application:

1. Select **Menu**.
2. Select **Set-up**.
3. Select **Transducer Set-up**.
4. Select **Depth Offset**.

The depth offset numeric adjust control is displayed.

5. Adjust the offset to the required value.

Setting the speed offset

From the fishfinder application:

1. Select **Menu**.
2. Select **Set-up**.
3. Select **Transducer Set-up**.
4. Select **Speed Offset**.

The speed offset numeric adjust control is displayed.

5. Adjust the offset to the required value.

Setting the Temperature offset

1. Select **Menu**.
2. Select **Set-up**.
3. Select **Transducer Set-up**.
4. Select **Temperature Offset**.

The temperature offset numeric adjust control is displayed.

5. Adjust the offset to the required value.

7.4 Thermal camera setup and checks

To ensure correct operation of the thermal camera you should setup and check the camera's main functions.

Before proceeding ensure that the camera is connected correctly, according to the instructions provided. If your system includes the optional Joystick Control Unit (JCU) and PoE (Power over Ethernet) injector, ensure these units are also connected correctly.

Set up the camera

You will need to:

- Adjust the image (contrast, brightness, and so on).
- Check camera movement (pan, tilt and home functions) (if applicable).

Adjusting the thermal camera image

With the thermal camera application displayed:

1. Select **Menu**.
2. Select **Adjust Contrast**.
3. Select the Contrast, Brightness, or Color option as appropriate.
The relevant numeric adjust control is displayed.
4. Adjust the value as required.
5. Select **Back** or **Ok** to confirm the new value.

Pan, Tilt, Zoom (PTZ) cameras



Panning and tilting, and the thermal image

On a touchscreen multifunction display you can pan and tilt the thermal camera image using the touchscreen.

	<p>Move your finger up and down the screen to tilt the camera up or down.</p>
	<p>Move your finger left and right on the screen to rotate the camera left or right (panning).</p>



Panning, Tilting and zooming the thermal image

On a multifunction display with physical buttons or when using a remote keypad you can pan, tilt and zoom the thermal camera image using the UniControl.

In some circumstances it may be better to use just the UniControl's rotary and joystick controls to manipulate the thermal camera view. For example, this method is ideal for finer control over the camera and is particularly useful in rough sea conditions.

	<p>UniControl joystick — is used for rotating the camera left or right (panning), or tilting the camera up or down.</p>
	<p>UniControl rotary — is used to zoom in and out.</p>

Resetting the thermal camera to the home position

When connected to a pan, tilt thermal camera the home position of the camera can be set.

In the thermal camera application:

1. Select **Menu**.
2. Select **Camera Home**.

The camera returns to its currently defined home position, and the “Home” icon appears on-screen momentarily.

Chapter 8: Maintaining your display

Chapter contents

- [8.1 Service and maintenance on page 94](#)
- [8.2 Product cleaning on page 94](#)

8.1 Service and maintenance

This product contains no user serviceable components. Please refer all maintenance and repair to authorized Raymarine dealers. Unauthorized repair may affect your warranty.

Routine equipment checks

Raymarine strongly recommends that you complete a number of routine checks to ensure the correct and reliable operation of your equipment.

Complete the following checks on a regular basis:

- Examine all cables for signs of damage or wear and tear.
- Check that all cables are securely connected.

8.2 Product cleaning

Best cleaning practices.

When cleaning products:

- If your product includes a display screen, do NOT wipe the screen with a dry cloth, as this could scratch the screen coating.
- Do NOT use abrasive, or acid or ammonia based products.
- Do NOT use a jet wash.

Cleaning the display case

The display unit is a sealed unit and does not require regular cleaning. If it is necessary to clean the unit, follow this basic procedure:

1. Switch off the power to the display.
2. Wipe the display with a clean, soft cloth (a microfibre cloth is ideal).
3. If necessary, use a mild detergent to remove grease marks.

Note: Do NOT use solvents or detergents on the screen itself.

Note: In certain conditions, condensation may appear inside the display screen. This will not harm the unit, and can be cleared by powering on the display for a short time.

Cleaning the display screen

A coating is applied to the display screen. This makes it water repellent, and prevents glare. To avoid damaging this coating, follow this procedure:

1. Switch off the power to the display.
2. Rinse the screen with fresh water to remove all dirt particles and salt deposits.
3. Allow the screen to dry naturally.
4. If any smears remain, very gently wipe the screen with a clean microfibre cleaning cloth (available from an opticians).

Cleaning the sun cover

The supplied sun cover features an adhesive surface. In certain conditions unwanted contaminants may stick to this surface. To avoid damaging the monitor display, clean the sun cover regularly following this procedure:

1. Carefully remove the sun cover from the display.
2. Rinse the sun cover with fresh water to remove all dirt particles and salt deposits.
3. Allow the sun cover to dry naturally.

Chapter 9: Troubleshooting

Chapter contents

- [9.1 Troubleshooting on page 96](#)
- [9.2 Power up troubleshooting on page 97](#)
- [9.3 Radar troubleshooting on page 98](#)
- [9.4 GPS troubleshooting on page 99](#)
- [9.5 Sonar troubleshooting on page 100](#)
- [9.6 Sonar crosstalk interference on page 103](#)
- [9.7 Thermal camera troubleshooting on page 105](#)
- [9.8 System data troubleshooting on page 107](#)
- [9.9 Video troubleshooting on page 108](#)
- [9.10 Wi-Fi troubleshooting on page 109](#)
- [9.11 Bluetooth troubleshooting on page 110](#)
- [9.12 Touchscreen troubleshooting on page 111](#)
- [9.13 Touchscreen alignment on page 112](#)
- [9.14 Miscellaneous troubleshooting on page 113](#)

9.1 Troubleshooting

The troubleshooting information provides possible causes and corrective action required for common problems associated with marine electronics installations.

All Raymarine products are, prior to packing and shipping, subjected to comprehensive test and quality assurance programs. However, if you experience problems with the operation of your product this section will help you to diagnose and correct problems in order to restore normal operation.

If after referring to this section you are still having problems with your unit, please contact Raymarine Technical Support for further advice.

9.2 Power up troubleshooting

Problems at power up and their possible causes and solutions are described here.

Product does not turn on or keeps turning off

Possible causes	Possible solutions
Blown fuse / tripped breaker	<ol style="list-style-type: none"> 1. Check condition of relevant fuses and breakers and connections, replace if necessary (Refer to the <i>Technical Specification</i> section of your product's installation instructions for fuse ratings.) 2. If fuse keeps blowing check for cable damage, broken connector pins or incorrect wiring.
Poor / damaged / insecure power supply cable / connections	<ol style="list-style-type: none"> 1. Check that the power cable connector is fully inserted into the unit and locked in position. 2. Check the power supply cable and connectors for signs of damage or corrosion, replace if necessary. 3. With the unit turned on, try flexing the power cable near to the display connector to see if this causes the unit to re-boot/loose power, replace if necessary. 4. Check the vessel's battery voltage, the condition of the battery terminals and power supply cables, ensuring connections are secure, clean and free from corrosion, replace if necessary. 5. With the product under load, using a multi-meter, check for high voltage drop across all connectors/fuses etc, replace if necessary.
Incorrect power connection	The power supply may be wired incorrectly, ensure the installation instructions have been followed.
Power source insufficient	With the product under load, using a multi-meter, check the power supply voltage as close to the unit as possible to establish actual voltage when the current is flowing. (Refer to the <i>Technical Specification</i> section of your product's installation instructions for power supply requirements.)

Product will not boot up (re-boot loop)

Possible causes	Possible solutions
Power supply and connection	See possible solutions from 'Products does not turn on or keeps turning off' above.
Software corruption	<ol style="list-style-type: none"> 1. In the unlikely event that the products software has become corrupted please try re-flashing the latest software from the Raymarine website. 2. On display products, as a last resort, you can try to perform a 'Power on Reset', however this will delete all settings/presets and user data (such as waypoints and tracks) and revert the unit back to factory defaults.

Performing a Power on Reset

Performing a 'Power on Reset' will delete all settings/presets and user data (such as waypoints and tracks) and revert the unit back to factory defaults.

1. Power the unit off.
2. Power the unit back on.
3. When the **LightHouse** logo appears Press and hold the **Power** button.
The Raymarine Initialization screen is displayed.
4. **Touch only displays:**
 - i. Press the **Power** button again to select '1 – Reset to factory defaults'.
A 7 second countdown will begin. When the countdown reaches zero the unit will be reset to factory default settings.

- ii. You can stop the reset process by pressing the **Power** button again before the countdown timer reaches zero.

This will select the second option: '2– Exit and start the application' and begin a new countdown timer.

5. Non-Touch and HybridTouch displays:

- i. Press the **WPT/MOB** button.
The unit will be reset to factory default settings.

9.3 Radar troubleshooting

Problems with the radar and their possible causes and solutions are described here.

Problem	Possible causes	Possible solutions
No Data or No scanner message	Radar scanner power supply	Check that the scanner power supply cable is sound and that all connections are tight and free from corrosion.
		Check relevant fuses and breakers.
		Check power source is of the correct voltage and sufficient current (using voltage booster if appropriate).
	SeaTalk ^{hs} / RayNet network problem	Check that the Scanner is correctly connected to a Raymarine network switch or SeaTalk ^{hs} crossover coupler (as applicable).
		Check the status of the Raymarine network switch.
		Check that SeaTalk ^{hs} / RayNet cables are free from damage.
Software mismatch between equipment may prevent communication.	Contact Raymarine technical support.	
Switch at scanner pedestal in OFF position	Ensure scanner pedestal switch is in ON position.	
Radar will not initialize (Voltage control module (VCM) stuck in "sleep mode")	Intermittent or poor power connection	Check power connection at VCM. (Voltage at input = 12 / 24 V, Voltage at output = 40 V)
The bearing of a target on the radar screen is incorrect.	The radar bearing alignment requires correcting.	Check and adjust radar bearing alignment.

9.4 GPS troubleshooting

Problems with the GPS and their possible causes and solutions are described here.

Problem	Possible causes	Possible solutions
"No Fix" GPS status icon is displayed.	Geographic location or prevailing conditions preventing satellite fix.	Check periodically to see if a fix is obtained in better conditions or another geographic location.
	GPS connection fault.	Ensure that external GPS connections and cabling are correct and fault free.
	External GPS antenna in poor position. For example: <ul style="list-style-type: none">• Below decks.• Close proximity to transmitting equipment such as VHF radio.	Ensure GPS antenna has a clear view of the sky.
	GPS installation problem.	Refer to the installation instructions.

Note: A GPS Status screen is available within the display. This provides satellite signal strength and other relevant information.

9.5 Sonar troubleshooting

Problems with the sonar and their possible causes and solutions are described here.

Scrolling image is not being displayed

Possible causes	Possible solutions
Sonar disabled	Select Ping Enable from the Sounder Set-up menu.
Incorrect transducer selected	Check that the correct transducer is selected in the Transducer Set-up menu.
Damaged cables	<ol style="list-style-type: none"> 1. Check that the transducer cable connector is fully inserted and locked in position. 2. Check the power supply cable and connectors for signs of damage or corrosion, replace if necessary. 3. With the unit turned on, try flexing the cable near to the display connector to see if this causes the unit to re-boot/loose power, replace if necessary. 4. Check the vessel's battery voltage, the condition of the battery terminals and power supply cables, ensuring connections are secure, clean and free from corrosion, replace if necessary. 5. With the product under load, using a multi-meter, check for high voltage drop across all connectors/fuses etc (this can cause the Fishfinder applications to stop scrolling or the unit to reset/turn off), replace if necessary.
Damaged or fouled transducer	Check the condition of the transducer ensuring it is not damaged and is free from debris/fouling, clean or replace as necessary.
Wrong transducer fitted	Ensure the transducer is compatible with your system.
SeaTalk ^{hs} / RayNet network problem.	<ul style="list-style-type: none"> • Check that the unit is correctly connected to the multifunction display or Raymarine network switch. If a crossover coupler or other coupler cable / adapter is used, check all connections ensuring connections are secure, clean and free from corrosion, replace if necessary.
Software mismatch between equipment may prevent communication.	Ensure all Raymarine products contain the latest available software, check the Raymarine website: www.raymarine.com/software for software compatibility.

No depth reading / lost bottom lock

Possible causes	Possible solutions
Transducer location	Check that the transducer has been installed in accordance with the instructions provided with the transducer.
Transducer angle	If the transducer angle is too great the beam can miss the bottom, adjust transducer angle and recheck.
Transducer kicked-up	If the transducer has a kick-up mechanism, check that it has not kicked up due to hitting an object.
Power source insufficient	With the product under load, using a multi-meter, check the power supply voltage as close to the unit as possible to establish actual voltage when the current is flowing. (Check your product's Technical specification for power supply requirements.)
Damaged or fouled transducer	Check the condition of the transducer ensuring it is not damaged and is free from debris / fouling.
Damaged cables	<ol style="list-style-type: none"> 1. Check the unit's connector for broken or bent pins. 2. Check that the cable connector is fully inserted into the unit and that the locking collar is in the locked position. 3. Check the cable and connectors for signs of damage or corrosion, replace if necessary. 4. With the unit turned on, try flexing the power cable near to the display connector to see if this causes the unit to re-boot/loose power, replace if necessary. 5. Check the vessel's battery voltage, the condition of the battery terminals and power supply cables, ensuring connections are secure, clean and free from corrosion, replace if necessary.

Possible causes	Possible solutions
	6. With the product under load, using a multi-meter, check for high voltage drop across all connectors/fuses etc (this can cause the Fishfinder applications to stop scrolling or the unit to reset/turn off), replace if necessary.
Vessel speed too high	Slow vessel speed and recheck.
Bottom too shallow or too deep	The bottom depth may be outside of the transducers depth range, move vessel to shallower or deeper waters as relevant and recheck.

Poor / problematic image

Possible causes	Possible solutions
Vessel stationary	Fish arches are not displayed if the vessel is stationary; fish will appear on the display as straight lines.
Scrolling paused or speed set too low	Unpause or increase sonar scrolling speed.
Sensitivity settings may be inappropriate for present conditions.	Check and adjust sensitivity settings or perform a Sonar reset.
Damaged cables	<ol style="list-style-type: none"> 1. Check the unit's connector for broken or bent pins. 2. Check that the cable connector is fully inserted into the unit and that the locking collar is in the locked position. 3. Check the cable and connectors for signs of damage or corrosion, replace if necessary. 4. With the unit turned on, try flexing the power cable near to the display connector to see if this causes the unit to re-boot/loose power, replace if necessary. 5. Check the vessel's battery voltage, the condition of the battery terminals and power supply cables, ensuring connections are secure, clean and free from corrosion, replace if necessary. 6. With the product under load, using a multi-meter, check for high voltage drop across all connectors/fuses etc (this can cause the Fishfinder applications to stop scrolling or the unit to reset/turn off), replace if necessary.
Transducer location	<p>Check that the transducer has been installed in accordance with the instructions provided with the transducer.</p> <p>If a transom mount transducer is mounted too high on the transom it may be lifting out of the water, check that the transducer face is fully submerged when planing and turning.</p>
Transducer kicked-up	If the transducer has a kick-up mechanism, check that it has not kicked up due to hitting an object.
Damaged or fouled transducer	Check the condition of the transducer ensuring it is not damaged and is free from debris / fouling.
Damaged transducer cable	Check that the transducer cable and connection is free from damage and that the connections are secure and free from corrosion.
Turbulence around the transducer at higher speeds may affect transducer performance	Slow vessel speed and recheck.
Interference from another transducer	<ol style="list-style-type: none"> 1. Turn off the transducer causing the interference. 2. Reposition the transducers so they are further apart.
Unit power supply fault	Check the voltage from the power supply, if this is too low it can affect the transmitting power of the unit.

Incorrect speed reading (from DST transducer)

Possible causes	Possible solutions
Paddle wheel fault	Check that the paddle wheel is clean.
No speed offset set	Add speed offset.
Incorrect calibration	Re-calibrate equipment

Possible causes	Possible solutions
Transducer does not have a speed element	Install transducer with speed element to enable speed readings.
Incorrect transducer selected (no speed displayed)	Select a transducer that supports speed measurement from the Transducer Set-Up menu.

9.6 Sonar crosstalk interference

There are 2 types of potential sonar crosstalk interference in a Raymarine sonar system:

1. **SideVision** sonar crosstalk interference
2. Multiple sonar crosstalk interference

The types of crosstalk interference that you may experience in your system depend on the combination and type of sonar equipment installed, and the way in which the equipment has been installed.

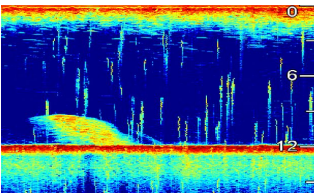
SideVision sonar crosstalk interference	Multiple sonar crosstalk interference
	
<p>Due to the high sensitivity of SideVision transducers, you may experience some minor crosstalk interference between the left and right receiving channels in areas of strong target returns. Examples of strong target returns include solid objects such as underwater bridge structure. This interference shows up in the Fishfinder application as subtle reflections from the right sonar image displayed in the left sonar image, or vice versa.</p>	<p>When using multiple sonar modules and transducers operating in overlapping frequency ranges, you may experience some crosstalk interference between the ranges. This interference is displayed in the Fishfinder application as vertical “rain drops” throughout the water column. These vertical “rain drops” indicate that 2 sonar modules are operating in close frequency proximity to one another.</p>

SideVision sonar crosstalk interference

Crosstalk interference is expected behavior in a high sensitivity device such as a **SideVision** transducer, and is not indicative of a fault with your transducer or sonar module.

Reducing multiple sonar crosstalk interference

Crosstalk interference in systems with multiple sonar modules and transducers is the result of a number of factors, including installation, operation, and environment.

- **Choose an equipment combination that minimizes overlapping frequencies.** Wherever possible, choose to use sonar modules and transducers that operate in different frequency ranges (“Channels”), for example CP100 and CP300 sonar modules and CPT-100 and B744V transducers. This will help to ensure that each component is operating in a distinct relative frequency range – for example, a “high” frequency range for the CP100 and a “low” frequency range for the CP300.
- **Only use the sonar channels that you really need.** Although it is possible to run multiple sonar

modules simultaneously in a Raymarine system, it may not always be necessary to do so. If you are in a scenario that requires only one sonar module to be active at a time, disable any other sonar modules by changing the Fishfinder application pane to a single one which only displays the output from one sonar module. Alternatively, disable the ping for any unused sonar modules by selecting **MENU > Channel > Ping > OFF** in the Fishfinder application.

- **Identify the sonar module and transducer that is causing the interference.** To do this, disable the ping or remove the power for one of the sonar modules in your system. If the interference in the Fishfinder application disappears immediately, you now know which device is causing the interference. If the interference doesn’t disappear, repeat the exercise again with the other sonar module(s) in your system, one at a time. Once you know which device is causing the interference, proceed with the following methods to reduce the interference from the relevant device.
- **Adjust the Interference Rejection Filter.** The default setting for all Raymarine MFDs is “Auto”. Changing this setting to “High” might help to reduce interference (**MENU > Setup > Sounder Setup > Interference Rejection**). Note that the Interference Rejection Filter setting is not available for all sonar modules.
- **Decrease the power output of the interfering transducer.** Adjusting the “Power Mode” in the Sensitivity Settings in the MFD’s Fishfinder application can help to minimize the presence of crosstalk interference (**MENU > Sensitivity Settings > Power Mode**). Note that the Power Mode setting is not available for all transducers.
- **Ensure that you have a common RF ground point for all electrical equipment on your vessel.** On vessels without an RF ground system, ensure all product drain wires (where available) are connected directly to the negative battery terminal. Ineffective RF grounding can cause electrical interference which may in turn result in sonar crosstalk interference.
- **Increase the physical distance between your sonar modules.** Electrical interference may be occurring between a cable on one sonar module, and a cable on a different sonar module. Ensure that your sonar modules are physically located as far away from each other as possible.
- **Increase the physical distance between your sonar transducers.** Electrical and / or acoustic interference may be occurring between the different transducers in your system. Ensure that your transducers are physically located as far away from each other as possible.

Note: Given the effort and potential difficulties involved in relocating sonar equipment, it should only be considered as a last resort when you judge the interference to be a significant problem which cannot be resolved using the methods described above.

Note: Due to physical size and other constraints that vary from vessel to vessel, it may not be possible to completely eliminate crosstalk interference from your system. However, this will not impede your ability to benefit from the full capabilities of your sonar system. Being able to easily identify the way in which interference is displayed in the Fishfinder application can sometimes be the best and easiest route to dealing with it.

9.7 Thermal camera troubleshooting

Problems with the thermal camera and their possible causes and solutions are described here.

Problem	Possible causes	Possible solutions
Video not displayed.	Camera is in Standby mode.	The camera will not display video if it is in Standby mode. Use the camera controls (either the thermal camera application or JCU) to “wake” the camera from standby.
	Problem with the thermal camera video connections.	<ul style="list-style-type: none"> • Check thermal camera video cables are sound and properly connected. • Ensure that the video is connected into video input 1 at the multifunction display or GVM. • Ensure that the correct video input is selected at the display.
	Problem with power supply to the camera or JCU (if used as the primary controller)	<ul style="list-style-type: none"> • Check the power connections to the camera and JCU / PoE injector (if used). • Ensure that the power switch / breaker is on. • Check the fuse / breaker state.
Cannot control thermal camera from Raymarine display or keyboard.	Thermal camera application is not running.	Ensure the thermal camera application is running on the multifunction display (as oppose to the video application which does not have camera controls).
Erratic or unresponsive controls.	Network problem.	Check that the controller and thermal camera are correctly connected to the network. (Note: This may be a direct connection or via a Raymarine network switch.)
		Check the status of the Raymarine network switch.
		Check that SeaTalk ^{hs} / RayNet cables are free from damage.
	Control conflict, e.g. caused by multiple users at different stations.	Ensure that no other controllers are in use at the same time.
	Problem with the controller.	Check power / network cabling to the controller and PoE injector (PoE only used with optional Joystick Control Unit). Check other controllers if available. If other controllers are operating this will eliminate the possibility of a more fundamental camera fault.
Cannot switch between thermal and visible (VIS / IR) video image .	Camera is not a dual payload model.	Only “dual payload” (dual lens) thermal cameras support VIS / IR switching.
	VIS / IR cable not connected.	Ensure that the VIS / IR cable is connected from the camera to the Raymarine system. (The IR-only cable does not support switching).
Noisy image.	Poor quality or faulty video cable.	Ensure that the video cable is no longer than necessary. The longer the cable is (or the smaller the wire gauge / thickness), the more severe the losses become. Use only high quality shielded cable suitable for a marine environment.
	Cable is picking up electromagnetic interference (EMI) from another device.	<ul style="list-style-type: none"> • Ensure you are using a high quality shielded cable. • Ensure proper cable separation, for example do not run data and power cables in close proximity with each other.

Problem	Possible causes	Possible solutions
Image too dark or too light.	Display brightness is set too low.	Use the brightness controls at the display to adjust accordingly.
	The contrast or brightness settings in the thermal camera application are set too low.	Use the appropriate menu in the thermal camera application to adjust the contrast and brightness of the image.
	The Scene Mode is not appropriate for the current conditions.	A particular environment may benefit from a different Scene Mode setting. For example, a very cold background (such as the sky) could cause the camera to use a wider temperature range than appropriate. Use the SCENE button.
Image freezes momentarily.	FFC (Flat Field Correction).	The image will pause momentarily on a periodic basis during the Flat Field Correction (FFC) cycle. Just prior to the FFC, a small green square will appear in the upper left corner of the screen.
Image is inverted (upside down).	Camera “Ball down” setting is incorrect.	Ensure that the Ball down setting within the thermal camera system setup menu is set correctly.

9.8 System data troubleshooting

Aspects of the installation can cause problems with the data shared between connected equipment. Such problems, their possible causes and solutions are described here.

Problem	Possible causes	Possible solutions
Instrument, engine or other system data is unavailable at all displays.	Data is not being received at the display.	Check the data bus (e.g. SeaTalk ^{ng}) wiring and connections.
		Check the overall integrity of the data bus (e.g. SeaTalk ^{ng}) wiring.
		If available refer to the reference guide for the data bus (e.g. SeaTalk ^{ng} reference manual).
	Data source (e.g. ST70 instrument or engine interface) is not operating.	Check the source of the missing data (e.g. ST70 instrument or engine interface).
		Check the power to the SeaTalk bus.
		Refer to the manufacturer's handbook for the equipment in question.
Software mismatch between equipment may prevent communication.	Contact Raymarine technical support.	
Instrument or other system data is missing from some but not all displays.	Network problem.	Check that all required equipment is connected to the network.
		Check the status of the Raymarine network Switch.
		Check that SeaTalk ^{hs} / RayNet cables are free from damage.
	Software mismatch between equipment may prevent communication.	Contact Raymarine technical support.

9.9 Video troubleshooting

Problems with the video inputs and their possible causes and solutions are described here.

Problem	Possible causes	Possible solutions
No signal message on screen (video image not displayed)	Cable or connection fault	Check that the connections are sound and free from corrosion.

9.10 Wi-Fi troubleshooting

Aspects of the installation can cause problems with the data shared between wireless devices. Such problems, their possible causes and solutions are described here.

Problem	Possible causes	Possible solutions
No wireless connection.	Tablet / smartphone does not have a wireless connection established with the multifunction display.	Ensure that Wi-Fi is enabled on the multifunction display (Homescreen: > Set-Up > System Settings > Wireless Connections > Wi-Fi > On).
		Ensure that the "Wi-Fi" option is enabled on the iPhone (available from the phone's Settings menu).
		Ensure that the Raymarine connection is selected as the Wi-Fi network. If a passcode has been specified for the multifunction display's Wi-Fi connection ensure that the same passcode is entered into the iPhone when prompted.
No Raymarine app on device.	Tablet / smartphone does not have Raymarine app installed and running.	Download the required Raymarine app from the relevant application store. Start the Raymarine app on your device.
	Mobile applications are NOT enabled on the multifunction display.	Enable "Viewing only" or "Remote Control" (Homescreen: > Set-Up > System Settings > Wireless Connections > Mobile Apps).
Raymarine app runs slowly or not at all.	Device not compatible with Raymarine app.	Recommended device requirements: <ul style="list-style-type: none"> • iOS Devices = Best performance achieved on iPhone 4 or later and iPad 2 or later. • Android/Kindle Fire = Best performance achieved with 1GHz processor and better and running 2.2.2. or later.
	MFD software incompatible with mobile application.	Ensure your MFD contains software application version 3.15 or later.
No waypoint / routes synchronization with Navionics Marine app.	Smartphone / tablet does not have "Navionics Marine" app installed and running.	Download the "Navionics Marine" app from the relevant app store. Start the "Navionics Marine" app on the device.
	Chart application is not running on the multifunction display.	Start the chart application on the multifunction display.
Weak or intermittent Wi-Fi signal.	Interference from other wireless devices in the vicinity.	Multiple wireless devices running simultaneously (such as laptops, phones, and other wireless devices) can sometimes cause wireless signal conflicts. Temporarily disable each wireless device in turn until you have identified the device causing the interference.
Smartphone / tablet can no longer connect to the internet or receive e-mails after using a Raymarine mobile app.	Device still connected to the multifunction display.	Ensure the access point on your device is switched back to your previous access point (e.g. the marina Wi-Fi).

9.11 Bluetooth troubleshooting

Aspects of the installation can cause problems with the data shared between wireless devices. Such problems, their possible causes and solutions are described here.

Problem	Possible causes	Possible solutions
No wireless connection.	iPhone does not have a Bluetooth connection established with the multifunction display.	Ensure that Bluetooth is enabled on the multifunction display (Homescreen: > Set-Up > System Settings > Connections > Bluetooth > On).
		Ensure that the “Bluetooth” option is enabled on the iPhone (available from the phone's Settings / General menu).
		Ensure that the Bluetooth device is paired with the multifunction display that you want to use it with. To do this: Homescreen: > Set-Up > System Settings > Connections > New Bluetooth Connection .
No media player control.	Media player device is not compatible with the Bluetooth 2.1+ EDR power class 1.5 (supported profile: AVRCP 1.0) or higher.	Check the Bluetooth compatibility with the device manufacturer. If the device is not Bluetooth 2.1+ EDR power class 1.5 (supported profile: AVRCP 1.0) compatible then it is not suitable for wireless use with the multifunction display.
	“Audio Control” is NOT enabled on the multifunction display.	Enable “Audio Control” (Homescreen: > Set-Up > System Settings > Connections > Connections Manager > Audio Control > On).
Weak or intermittent Bluetooth signal.	Interference from other wireless devices in the vicinity.	Multiple wireless devices running simultaneously (such as laptops, phones, and other wireless devices) can sometimes cause wireless signal conflicts. Temporarily disable each wireless device in turn until you have identified the device causing the interference.

9.12 Touchscreen troubleshooting

Problems with the touchscreen and their possible causes and solutions are described here.

Problem	Possible causes	Possible solutions
Touchscreen does not operate as expected.	Touch lock is enabled.	Use the Joystick to turn off the touch lock on the home screen.
	Screen is not being operated with bare fingers, for example gloves are being worn.	Bare fingers must make contact with the screen for correct operation. Alternatively you may use conductive gloves.
	Touchscreen requires calibration.	Use the setup menus to calibrate the touchscreen.
	Saltwater deposits on the screen.	Carefully clean and dry the screen in accordance with the instructions provided.

9.13 Touchscreen alignment

If the touchscreen is misaligned to your touch, you can realign it to improve the accuracy.

Realignment involves a simple exercise to align an on-screen object with your touch. For best results, perform this exercise when your vessel is anchored or moored.

Note: This only applies to touchscreen multifunction displays.

Aligning the touchscreen

With the homescreen displayed:

1. Select **Set-up**.
2. Select **Maintenance**.
3. Select **Touchscreen Alignment**.
4. Place your finger over the on-screen object momentarily, then remove it.
5. Repeat the action a further 3 times.
6. If the operation was successful, an "Alignment Completed" message is displayed.
7. Select **Exit** to return to the Maintenance menu.
8. If the operation was unsuccessful at any point during the alignment exercise, an "Incorrect touch detected" message is displayed, the alignment exercise is repeated.
9. After 2 failed alignment exercises you may be asked to perform a precision alignment exercise.

9.14 Miscellaneous troubleshooting

Miscellaneous problems and their possible causes and solutions are described here.

Problem	Possible causes	Possible solutions
Display behaves erratically: <ul style="list-style-type: none"> • Frequent unexpected resets. • System crashes or other erratic behavior. 	Intermittent problem with power to the display.	Check relevant fuses and breakers.
		Check that the power supply cable is sound and that all connections are tight and free from corrosion.
		Check that the power source is of the correct voltage and sufficient current.
	Software mismatch on system (upgrade required).	Go to www.raymarine.com and click on support for the latest software downloads.
Corrupt data / other unknown issue.	Perform a factory reset. <div style="border: 1px solid black; padding: 5px; margin-top: 10px;"> <p>Important: This will result in the loss of any settings and data (such as waypoints) stored on the product. Save any important data to a memory card before resetting.</p> </div>	

Chapter 10: Technical specification

Chapter contents

- 10.1 Product dimensions on page 116
- 10.2 Weight specification - eS Series on page 116
- 10.3 Power specification — eS7x displays on page 117
- 10.4 Power specification — eS9x displays on page 117
- 10.5 Power specification — eS12x displays on page 118
- 10.6 Display specification — eS7x displays on page 118
- 10.7 Display specification — eS9x displays on page 119
- 10.8 Display specification — eS12x displays on page 119
- 10.9 Data connections and storage — eS7x displays on page 120
- 10.10 Data connections and storage — eS9x and eS12x displays on page 120
- 10.11 Environmental specification on page 121
- 10.12 Internal GNSS (GPS / GLONASS) receiver specification on page 121
- 10.13 Internal 600 W sonar specification on page 122
- 10.14 Internal **CHIRP DownVision™** specification on page 122
- 10.15 Electronic chart specification on page 123
- 10.16 Conformance specification on page 123

10.1 Product dimensions

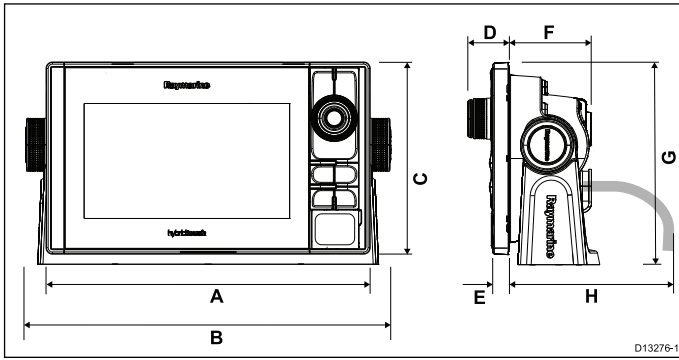

	eS7x	eS9x	eS12x
A	244.2 mm (9.6 in.)	299.3 mm (11.8 in.)	358 mm (14 in.)
B	275.2 mm (10.8 in.)	332 mm (13 in.)	390.5 mm (15.4 in.)
C	144.7 mm (5.7 in.)	173.8 mm (6.8 in.)	222.8 mm (8.8 in.)
D	31 mm (1.2 in.)	32 mm (1.3 in.)	31.9 mm (1.3 in.)
E	12.5 mm (0.49 in.)	13.5 mm (0.53 in.)	13.5 mm (0.53 in.)
F	61.9 mm (2.4 in.)	64.7 mm (2.6 in.)	64.4 mm (2.5 in.)
G	152.5 mm (6 in.)	184.6 mm (7.3 in.)	244.5 mm (9.6 in.)
H	150 mm (5.9 in.)	150 mm (5.9 in.)	150 mm (5.9 in.)

10.2 Weight specification - eS Series

eS7x	1,695 Kg (3.74 lbs)
eS9x	2,567 Kg (5.66 lbs)
eS12x	3,620 Kg (7.98 lbs)

10.3 Power specification — eS7x displays

Nominal supply voltage	12 V dc to 24 V dc
Operating voltage range	10.8 V dc to 31.2 V dc
Fuse / Breakers	Internal fuse
LEN (Refer to Seataalk ^{ng} reference manual for further information).	1

10.4 Power specification — eS9x displays

Nominal supply voltage	12 V dc to 24 V dc
Operating voltage range	10.8 V dc to 31.2 V dc
Fuse / Breakers	15 A in-line fuse
LEN (Refer to Seataalk ^{ng} reference manual for further information).	1

10.5 Power specification — eS12x displays

Nominal supply voltage	12 V dc to 24 V dc
Operating voltage range	10.8 V dc to 31.2 V dc
Fuse / Breakers	15 A in-line fuse
LEN (Refer to Seataalk ^{ng} reference manual for further information).	1

10.6 Display specification — eS7x displays

Size	7 in.
Type	TFT backlit LED
Color depth	24-bit
Resolution	800 x 480 pixels (WVGA)
Ratio	16:9
Viewing angle	<ul style="list-style-type: none">• Top / Bottom: 60° / 70°• Left / Right: 70° / 70°
Maximum allowable wrongly illuminated pixels	6

10.7 Display specification — eS9x displays

Size	9 in.
Type	TFT backlit LED
Color depth	24-bit
Resolution	800 x 480 pixels (WVGA)
Ratio	16:9
Viewing angle	<ul style="list-style-type: none">• Top / Bottom: 80° / 80°• Left / Right: 80° / 80°
Maximum allowable wrongly illuminated pixels	6

10.8 Display specification — eS12x displays

Size	12.1 in.
Type	TFT backlit LED
Color depth	24-bit
Resolution	1280 x 800 pixels (WXGA)
Ratio	16:10
Viewing angle	<ul style="list-style-type: none">• Top / Bottom: 80° / 80°• Left / Right: 80° / 80°
Maximum allowable wrongly illuminated pixels	6

10.9 Data connections and storage — eS7x displays

Wired connections

NMEA 0183	2x NMEA 0183 ports via optional Video/NMEA cable (R70414): <ul style="list-style-type: none"> • NMEA port 1: Input and output, 4800 / 38400 baud • NMEA port 2: Input only, 4800 / 38400 baud
NMEA 2000	1 x SeaTalk^{ng} ® connection
Network (SeaTalk^{hs})	• 1 x RayNet type SeaTalk^{hs} port. 10/100 Mbits/s
Video input	1 x Composite female BNC connector via optional Video/NMEA cable (R70414)

Wireless connections

Wi-Fi	802.11 b / g
Bluetooth	Bluetooth 2.1+ EDR power class 1.5 (supported profile: AVRCP 1.0)

Storage

Internal	6GB
External	2 x MicroSD card slots providing up to 64GB (2 x 32GB cards)

10.10 Data connections and storage — eS9x and eS12x displays

Wired connections

NMEA 0183	2x NMEA 0183 ports via Power/Video/NMEA cable: <ul style="list-style-type: none"> • NMEA port 1: Input and output, 4800 / 38400 baud • NMEA port 2: Input only, 4800 / 38400 baud
NMEA 2000	1 x SeaTalk^{ng} ® connection
Network (SeaTalk^{hs})	• 2 x RayNet type SeaTalk^{hs} port. 10/100 Mbits/s
Video input	1 x Composite female BNC connector via Power/Video/NMEA cable
Video output	1 x HDMI connector
GA150	1 x TNC type external GNSS antenna connection

Wireless connections

Wi-Fi	802.11 b / g
Bluetooth	Bluetooth 2.1+ EDR power class 1.5 (supported profile: AVRCP 1.0)

Storage

Internal	6GB
External	2 x MicroSD card slots providing up to 64GB (2 x 32GB cards)

10.11 Environmental specification

Environmental specifications below apply to all display variants

Operating temperature	-25 °C to +55 °C (-13 °F to 131 °F)
Storage temperature	-30 °C to +70 °C (-22 °F to 158 °F)
Relative humidity	Maximum 75%
Waterproof rating	• IPX6 and IPX7

10.12 Internal GNSS (GPS / GLONASS) receiver specification

Channels	72
Cold start	<2 minutes
Receiver IC Sensitivity	-167 dBm (Tracking) / -148 dBm (Acquisition)
GNSS compatibility	<ul style="list-style-type: none"> • GPS • GLONASS • * Beidou
SBAS compatibility	<ul style="list-style-type: none"> • WAAS • EGNOS • MSAS
Special features	Active Jamming and Interference Reduction
Operating frequency	<ul style="list-style-type: none"> • GPS L1 C/A • GLONASS L10F • Beidou B1
Signal Acquisition	Automatic
Almanac Update	Automatic
Geodetic Datum	WGS-84 (alternatives available through Raymarine MFD)
Refresh Rate	10 Hz (10 times per second Concurrent GNSS)
Antenna	<ul style="list-style-type: none"> • Internal — Ceramic chip mounted near top of unit
Position Accuracy	<ul style="list-style-type: none"> • Without SBAS: <= 15 metres 95% of the time • With SBAS: <= 5 metres 95% of the time

10.13 Internal 600 W sonar specification

The following specification only applies to multifunction displays that include a built-in 600 W sonar module.

Operating frequencies	50 / 83 / 200 KHz
Transmit power	Up to 600 W RMS, depending on transducer
Depth range	Up to 3000 ft, depending on transducer

10.14 Internal CHIRP DownVision™ specification

The following specification only applies to multifunction displays that include a built-in **CHIRP DownVision™** sonar module.

Channels	2 x CHIRP (1 x traditional sonar and 1 x DownVision™)
Beam coverage	<ul style="list-style-type: none">• Sonar — conical beam.• DownVision™ — Wide (port / starboard) and thin (fore / aft) fan beam.
Depth range	0.6 M (2 ft) to 183 m (600 ft). Depending on water conditions, the Sonar channel maybe able to achieve increased depth range over the DownVision™ channel.

10.15 Electronic chart specification

Embedded electronic charts	<ul style="list-style-type: none"> • LightHouse Charts world base map. • Navionics world base map. • Jeppesen world base map
Compatible LightHouse cartography	<ul style="list-style-type: none"> • Vector — LightHouse charts • Raster — LightHouse charts
Compatible Navionics cartography	<ul style="list-style-type: none"> • Navionics Ready to Navigate • Navionics Silver • Navionics Gold • Navionics Gold+ • Navionics Platinum • Navionics Platinum+ • Navionics Fish'N Chip • Navionics Hotmaps
Compatible Jeppesen cartography	<ul style="list-style-type: none"> • C-MAP Essentials • C-MAP 4D MAX • C-MAP 4D MAX+

Note:

Refer to the Raymarine website (www.raymarine.com) for the latest list of supported charts.

10.16 Conformance specification

Conformance certification applies to all display variants

Conformance	<ul style="list-style-type: none"> • NMEA 2000 certification • WiFi Alliance certification • Bluetooth certification • Europe: 1999/5/EC • Australia and New Zealand: C-Tick, Compliance Level 2 • FCC 47CFR part 15 • Industry Canada RSS210
--------------------	--

Chapter 11: Technical support

Chapter contents

- 11.1 Raymarine customer support on page 126
- 11.2 Learning resources on page 126
- 11.3 Third-party support on page 127

11.1 Raymarine customer support

Raymarine provides a comprehensive customer support service. You can contact customer support through the Raymarine website, telephone and e-mail. If you are unable to resolve a problem, please use any of these facilities to obtain additional help.

Web support

Please visit the customer support area of our website at:

www.raymarine.com

This contains Frequently Asked Questions, servicing information, e-mail access to the Raymarine Technical Support Department and details of worldwide Raymarine agents.

Telephone and e-mail support

In the USA:

- **Tel:** +1 603 324 7900
- **Toll Free:** +1 800 539 5539
- **E-mail:** support@raymarine.com

In the UK, Europe, and the Middle East:

- **Tel:** +44 (0)13 2924 6777
- **E-mail:** ukproduct.support@raymarine.com

In Southeast Asia and Australia:

- **Tel:** +61 (0)29479 4800
- **E-mail:** aus.support@raymarine.com

Product information

If you need to request service, please have the following information to hand:

- Product name.
- Product identity.
- Serial number.
- Software application version.
- System diagrams.

You can obtain this product information using the menus within your product.

Viewing product information

With the homescreen displayed:

1. Select **Set-up**.
2. Select **Maintenance**.
3. Select **Diagnostics**.
4. Select **Select Device**.
5. Select the relevant product from the list.
6. Select **Show All Data**.

11.2 Learning resources

Raymarine has produced a range of learning resources to help you get the most out of your products.

Video tutorials

	Raymarine official channel on YouTube: <ul style="list-style-type: none">• http://www.youtube.com/user/RaymarineInc
	Video Gallery: <ul style="list-style-type: none">• http://www.raymarine.co.uk/view/?id=2679
	Product Support videos: <ul style="list-style-type: none">• http://www.raymarine.co.uk/view/?id=4952

Note:

- Viewing the videos requires a device with an Internet connection.
- Some videos are only available in English.

Training courses

Raymarine regularly runs a range of in-depth training courses to help you make the most of your products. Visit the Training section of the Raymarine website for more information:

- <http://www.raymarine.co.uk/view/?id=2372>

FAQs and Knowledge Base

Raymarine has produced an extensive set of FAQs and a Knowledge Base to help you find more information and troubleshoot any issues.

- <http://www.raymarine.co.uk/knowledgebase/>

Technical support forum

You can use the Technical support forum to ask a technical question about a Raymarine product or to find out how other customers are using their Raymarine equipment. The resource is regularly updated with contributions from Raymarine customers and staff:

- <http://raymarine.ning.com/>

11.3 Third-party support

Contact and support details for third-party suppliers can be found on the appropriate websites.

Fusion

www.fusionelectronics.com

Navionics

www.navionics.com

Sirius

www.sirius.com

Chapter 12: Spares and accessories

Chapter contents

- 12.1 eS Series spares and accessories on page 130
- 12.2 Digital ClearPulse Transducers and accessories on page 130
- 12.3 **DownVision™** transducers and accessories on page 131
- 12.4 Network hardware on page 132
- 12.5 Network cable connector types on page 133
- 12.6 **RayNet** to **RayNet** cables and connectors on page 135
- 12.7 Network cable types on page 136
- 12.8 SeaTalk^{ng} cabling components on page 136
- 12.9 SeaTalk^{ng} cables and accessories on page 137

12.1 eS Series spares and accessories

Spares

Item	Part numbers		
	eS7x	eS9x	eS12x
Trunnion (bracket) mount kit	R70381	R70384	R70389
Bezel pieces and Home/Menu button kit	R70379	R70383	R70387
Suncover	R70378	R70382	R70386
Power cable – Straight 1.5 m (4.9 ft)	R70159	N/A	N/A
Power and data cable – Straight 1.5 m (4.9 ft)	N/A	R62379	R62379
Flush mount seal kit	R70380	R70385	R70388

Accessories

Item	Part numbers		
	eS7x	eS9x	eS12x
Video/NMEA 0183 cable	R70414	N/A	N/A
Rear mounting bracket	A80341	A80342	A80343
Power cable – Angled 1.5 m (4.9 ft)	A80221	N/A	N/A angled power cable
Power and data cable – Angled 1.5 m (4.9 ft)	N/A	R70029	R70029
RMK-9 MFD remote network keypad	A80217		
RCU-3 Bluetooth remote control	E62351		

12.2 Digital ClearPulse Transducers and accessories

The transducers listed below can be connected directly to sonar variant MFDs.

Depth transducers

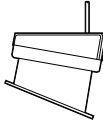
Part number	Image	Mounting	Housing
A80170		In-Hull	P79

Depth and Temperature transducers

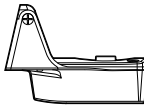
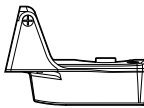
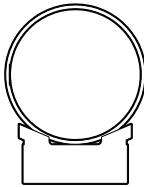
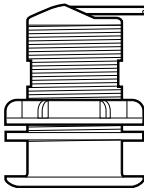
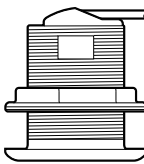
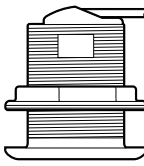
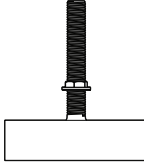
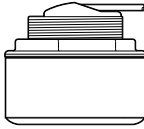
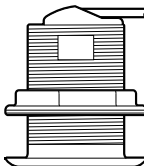
Part number	Image	Mounting	Housing
A80150		Transom	P48
A102140		Transom	P48 (widebeam)
E66073		In-hull / Trolling	P74
A80171		Thru-hull — Low profile	P319
E66087		Thru-hull	B60 (20° angle)
E66088		Thru-hull	B60 (12° angle)
A80172		Thru-hull	B258
A80173		Thru-hull — Low profile	B164
A80214		Thru-hull	SS60 (600W, 0° angle)

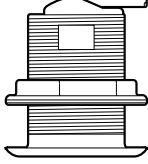
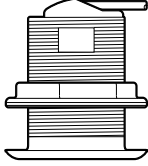
Part number	Image	Mounting	Housing
A80215		Thru-hull	SS60 (600W, 12° angle)
A80216		Thru-hull	SS60 (600W, 20° angle)

Depth, Speed and Temperature (DST) transducers

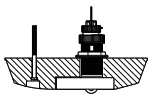
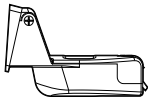
Part number	Image	Mounting	Housing
A66090		Thru-hull	B744V (including fairing block)
A102138		Transom	P58

Accessories

Part number	Item	Notes
A62363	1 m (3.28 ft) Minn Kota transducer adaptor cable	Only for direct connection to sonar variant multifunction display.
E66066	0.5 m (1.64 ft) transducer adaptor cable for DSM transducers	For connecting any 600 watt sonar module-compatible sonar transducer directly to a sonar variant multifunction display.
E66074	3 m (9.84 ft.) transducer extension cable	

12.3 DownVision™ transducers and accessories

The transducers listed below can be connected directly to **DownVision™** variant MFDs.

Depth and temperature transducers

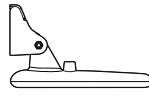
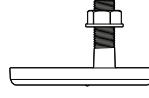
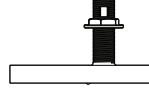
Part number	Image	Mounting	Housing
A80270		Transom	CPT-100 plastic
A80277		Thru-hull	CPT-110 plastic
A80271		Thru-hull	CPT-120 bronze

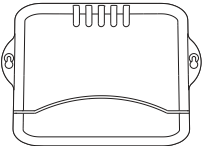
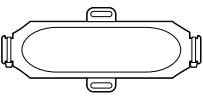
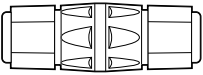

Part number	Description	Notes
A80207	Transom transducer shield for vessels with a trolling motor	
A80273	4 m (13.12 ft) transducer extension cable for CPT-100, CPT-110 and CPT-120 transducers	

12.4 Network hardware

Item	Part number	Notes
HS5 RayNet network switch 	A80007	5–port switch for network connection of multiple devices featuring RayNet connectors. Equipment with RJ45 SeaTalk ^{hs} connectors can also be connected using suitable adapter cables.
RJ45 SeaTalk ^{hs} network switch 	E55058	8–port switch for network connection of multiple SeaTalk ^{hs} devices featuring RJ45 connectors.
RJ45 SeaTalk ^{hs} crossover coupler 	E55060	<ul style="list-style-type: none"> • Enables direct connection of RJ45 SeaTalk^{hs} devices to smaller systems where a switch is not required. • Enables the connection of RJ45 SeaTalk^{hs} devices to a HS5 RayNet network switch (in conjunction with suitable adapter cables). • Enables 2 RJ45 SeaTalk^{hs} cables to be connected together to extend the length of the cabling. <p>Recommended for internal installations.</p> <div style="border: 1px solid black; padding: 5px; margin-top: 10px;"> <p>Important: Do NOT use crossover devices for POE (Power Over Ethernet) connections.</p> </div>
Ethernet RJ45 coupler 	R32142	<ul style="list-style-type: none"> • Enables direct connection of RJ45 SeaTalk^{hs} devices to smaller systems where a switch is not required. • Enables the connection of RJ45 SeaTalk^{hs} devices to a HS5 RayNet network switch (in conjunction with suitable adapter cables). • Enables 2 RJ45 SeaTalk^{hs} cables to be connected together to extend the length of the cabling. <p>Recommended for external installations.</p>

12.5 Network cable connector types

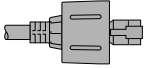
There are 2 types of network cable connector — SeaTalk^{hs} and RayNet.

 A SeaTalk ^{hs} connector, which is a rectangular metal plug with a central pin and a smaller side pin.	<p>SeaTalk^{hs} connector — used for connecting SeaTalk^{hs} devices to a Raymarine network switch via SeaTalk^{hs} cables.</p>
 A RayNet connector, which is a cylindrical metal plug with a series of raised ridges on its side.	<p>RayNet connector — used for connecting Raymarine network switches and SeaTalk^{hs} devices to the multifunction display via RayNet cables. Also required for connecting a crossover coupler if only one device is being connected to the display's Network connector.</p>

RayNet to RJ45 adapter cables

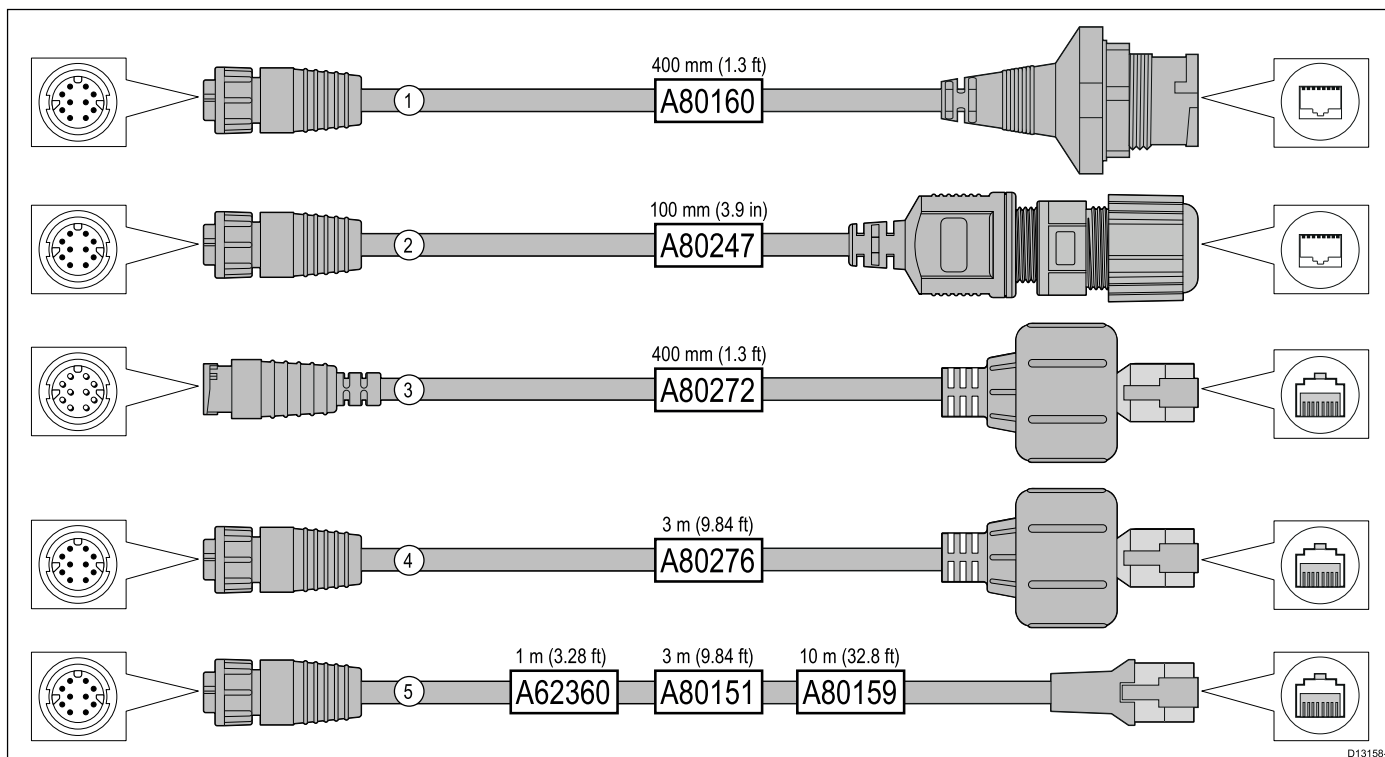

D13158-1

	Description	Typical use	Quantity
1	<p>Adapter cable with a RayNet (female) socket on one end, and a waterproof (female) socket on the other end accepting the following cables with an RJ45 SeaTalk^{hs} waterproof locking (male) plug:</p> <ul style="list-style-type: none"> • A62245 (1.5 m). • A62246 (15 m). 	<p>A typical use for this adapter cable is to connect a DSM300 sonar module to a LightHouse MFD, using all-waterproof cable connections. This adapter cable will also accept the following RJ45 SeaTalk^{hs} cables, although the RJ45 plug that connects at the equipment end (e.g. DSM300) will NOT be waterproof:</p> <ul style="list-style-type: none"> • E55049 (1.5 m). • E55050 (5 m). • E55051 (10 m). • A62135 (15 m). • E55052 (20 m). 	1
2	<p>Adapter cable with a RayNet (female) socket on one end, and a waterproof (female) RJ45 socket on the other end, along with a locking gland for a watertight fit.</p>	<p>Directly connect a Raymarine radar scanner with an RJ45 SeaTalk^{hs} (male) cable to a RayNet network switch (e.g. HS5) or LightHouse MFD.</p>	1
3	<p>Adapter cable with a RayNet (male) plug on one end, and an RJ45 SeaTalk^{hs} waterproof (male) plug on the other end.</p>	<p>Connect a legacy G-Series GPM-400, C-Series Widescreen or E-Series Widescreen MFD to a Raymarine radar scanner supplied with a RayNet power / data cable.</p>	1
4	<p>Adapter cable with a RayNet (female) socket on one end, and an RJ45 SeaTalk^{hs} waterproof (male) plug on the other end.</p>	<p>Connect a legacy G-Series GPM-400, C-Series Widescreen or E-Series Widescreen MFD to a RayNet network switch (e.g. the HS5).</p>	1
5	<p>Adapter cable with a RayNet (female) socket on one end, and an RJ45 SeaTalk^{hs} (female) socket on the other end.</p>	<p>Connect a LightHouse MFD to a legacy SR6 switch / weather receiver or a legacy 8–port SeaTalk^{hs} network switch. Another common use for the cable is in conjunction with a crossover coupler (E55060 or R32142) to connect Raymarine products with an RJ45 connection (e.g. radar scanner, thermal camera or DSM300) to a LightHouse MFD or RayNet network switch (e.g. the HS5).</p>	1

12.6 RayNet to RayNet cables and connectors

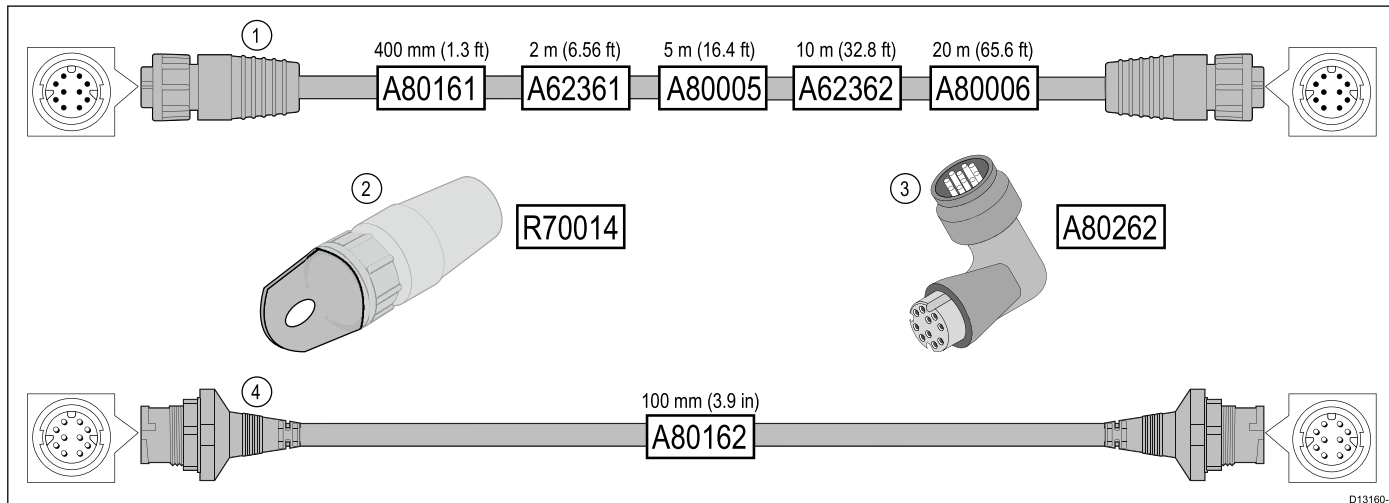

D13160-1

	Description	Typical use	Quantity
1	Standard RayNet connection cable with a RayNet (female) socket on both ends.	Suitable for connecting all RayNet equipment directly to LightHouse multifunction displays featuring a RayNet connector. Can also be used to connect RayNet equipment via a RayNet network switch (e.g. HS5).	1
2	RayNet cable puller (5 pack).	These “handles” securely attach to the twist-lock on RayNet cables, enabling you to pull the cables through conduits and other obstacles.	5
3	RayNet to RayNet right-angle coupler / adapter.	Suitable for connecting RayNet cables at 90° (right angle) to devices, for installations where space is limited. For example, use this adapter to connect a RayNet cable to a multifunction display when there is not enough space behind the display for the usual cable bend radius required by a standard RayNet cable. This adapter features a RayNet (female) socket at one end, and a RayNet (male) plug at the other end.	1
4	Adapter cable with a RayNet (male) plug on both ends.	Suitable for joining (female) RayNet cables together for longer cable runs.	1

12.7 Network cable types

There are 2 types of **SeaTalk^{hs}** network cable — “patch” and “network”.

- **Patch** — for connecting the following devices to a Raymarine network switch:
 - Thermal camera via PoE injector.
 - Additional Raymarine network switch.
 - PC or laptop using **Voyage Planner** software.
- **Network** — for connecting the following devices to a Raymarine network switch:
 - Sonar Module.
 - SR100 Sirius weather receiver.
 - Additional compatible Raymarine multifunction displays.

SeaTalk^{hs} network cables

Cable	Part number
1.5 m (4.9 ft) SeaTalk ^{hs} network cable	E55049
5 m (16.4 ft) SeaTalk ^{hs} network cable	E55050
10 m (32.8 ft) SeaTalk ^{hs} network cable	E55051
20 m (65.6 ft) SeaTalk ^{hs} network cable	E55052

SeaTalk^{hs} patch cables

Cable	Part number
1.5 m (4.9 ft) SeaTalk ^{hs} patch cable	E06054
5 m (16.4 ft) SeaTalk ^{hs} patch cable	E06055
10 m (32.8 ft) SeaTalk ^{hs} patch cable	E06056
15 m (49.2 ft) SeaTalk ^{hs} patch cable	A62136
20 m (65.6 ft) SeaTalk ^{hs} patch cable	E06057

12.8 SeaTalk^{ng} cabling components

SeaTalk^{ng} cabling components and their purposes.

Connection / Cable	Notes
Backbone cable (various lengths)	The main cable carrying data. Spurs from the backbone are used to connect SeaTalk ^{ng} devices.
T-piece connector	Used to make junctions in the backbone to which devices can then be connected.
Terminator	Required at either end of the backbone.
Inline terminator	Used to connect a spur cable directly to the end of a backbone; useful for longer cable runs.
Spur cable	Used to connect devices to the backbone. Devices may be daisy chained or connected directly to the T-pieces.
SeaTalk ^{ng} 5-way connector	Used to branch, split, or make additional connections in SeaTalk or SeaTalk ^{ng} networks.
Blanking plug	Inserted into unused spur connector positions in a 5-way connector or T-piece.

12.9 SeaTalk^{ng} cables and accessories

SeaTalk^{ng} cables and accessories for use with compatible products.

Description	Part No	Notes
SeaTalk ^{ng} starter kit	T70134	Includes: <ul style="list-style-type: none"> • 1 x 5 Way connector (A06064) • 2 x Backbone terminator (A06031) • 1 x 3 m (9.8 ft) spur cable (A06040) • 1 x Power cable (A06049)
SeaTalk ^{ng} Backbone Kit	A25062	Includes: <ul style="list-style-type: none"> • 2 x 5 m (16.4 ft) Backbone cable (A06036) • 1 x 20 m (65.6 ft) Backbone cable (A06037) • 4 x T-piece (A06028) • 2 x Backbone terminator (A06031) • 1 x Power cable (A06049)
SeaTalk ^{ng} 0.4 m (1.3 ft) spur	A06038	
SeaTalk ^{ng} 1 m (3.3 ft) spur	A06039	
SeaTalk ^{ng} 3 m (9.8 ft) spur	A06040	
SeaTalk ^{ng} 5 m (16.4 ft) spur	A06041	
SeaTalk ^{ng} 0.4 m (1.3 ft) elbow spur	A06042	
SeaTalk ^{ng} 0.4 m (1.3 ft) backbone	A06033	
SeaTalk ^{ng} 1 m (3.3 ft) backbone	A06034	
SeaTalk ^{ng} 3 m (9.8 ft) backbone	A06035	
SeaTalk ^{ng} 5 m (16.4 ft) backbone	A06036	
SeaTalk ^{ng} 9 m (29.5 ft) backbone	A06068	
SeaTalk ^{ng} 20 m (65.6 ft) backbone	A06037	
SeaTalk ^{ng} to bare ends 1 m (3.3 ft) spur	A06043	
SeaTalk ^{ng} to bare ends 3 m (9.8 ft) spur	A06044	

Description	Part No	Notes
SeaTalk ^{ng} Power cable	A06049	
SeaTalk ^{ng} Terminator	A06031	
SeaTalk ^{ng} T-piece	A06028	Provides 1 x spur connection
SeaTalk ^{ng} 5-way connector	A06064	Provides 3 x spur connections
SeaTalk ^{ng} backbone extender	A06030	
SeaTalk to SeaTalk ^{ng} converter kit	E22158	Allows the connection of SeaTalk devices to a SeaTalk ^{ng} system.
SeaTalk ^{ng} Inline terminator	A80001	Provides direct connection of a spur cable to the end of a backbone cable. No T-piece required.
SeaTalk ^{ng} Blanking plug	A06032	
ACU / SPX SeaTalk ^{ng} spur cable 0.3 m (1.0 ft)	R12112	Connects an SPX course computer or an ACU to a SeaTalk ^{ng} backbone.
SeaTalk (3 pin) to SeaTalk ^{ng} adaptor cable 0.4 m (1.3 ft)	A06047	
SeaTalk to SeaTalk ^{ng} spur 1 m (3.3 ft) spur	A22164	
SeaTalk2 (5 pin) to SeaTalk ^{ng} adaptor cable 0.4 m (1.3 ft)	A06048	
DeviceNet adaptor cable (Female)	A06045	Allows the connection of NMEA 2000 devices to a SeaTalk ^{ng} system.
DeviceNet adaptor cable (Male)	A06046	Allows the connection of NMEA 2000 devices to a SeaTalk ^{ng} system.
DeviceNet adaptor cable (Female) to bare ends.	E05026	Allows the connection of NMEA 2000 devices to a SeaTalk ^{ng} system.
DeviceNet adaptor cable (Male) to bare ends.	E05027	Allows the connection of NMEA 2000 devices to a SeaTalk ^{ng} system.

Appendix A Connectors and pinouts

eS7x NMEA 0813 / Video connector

Power, data, and video connector

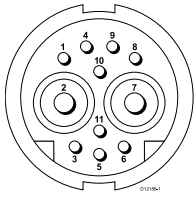

Item	Remarks
Identification	PWR / NMEA / Video
Connector type	11 pin twist-lock
Current source to network	No current sourced for external devices
Current sink from network	<ul style="list-style-type: none"> PSU: Main Power input. NMEA: No power required for interface. Video: No power required for interface.

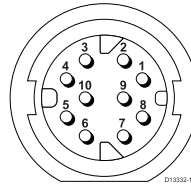

Pin	Cable	Signal
1	White	Port 1 input positive
2	Green	Port 1 input negative
3	Orange/White	Port 2 input positive
4	Orange/Green	Port 2 input negative
5	Shielding	BNC shell
6	Coax center	BNC Center
7	Yellow	Port 1 output positive
8	Brown	Port 1 output negative
9	Drain	Ground
10	Not connected	Not connected

Power, data and video cable cores and colors

Signal	Pin	AWG	Color
BATT+	2	16	Red
BATT-	7	16	Black
SCREEN	10	26	Black
NMEA1 TX+	8	26	Yellow
NMEA1 TX-	9	26	Brown
NMEA1 RX+	1	26	White
NMEA1 RX-	4	26	Green
NMEA2 RX+	3	26	Orange / White
NMEA2 RX-	11	26	Orange / Green
VIDEO IN	6	RG179 coaxial	
VIDEO RTN	5	Screen	

Network connector

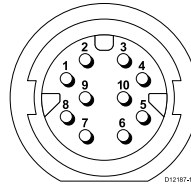

Pin	Cable	Signal	Description
1	White / Orange	Ethernet (pair 2)	Bi-directional Pair 2+
2	Orange	Ethernet (pair 2)	Bi-directional Pair 2-
3	Blue	Ethernet (pair 1)	Bi-directional Pair 1+
4	White / Blue	Ethernet (pair 1)	Bi-directional Pair 1-
5	White / Green	Ethernet (pair 3)	Bi-directional Pair 3+
6	Green	Ethernet (pair 3)	Bi-directional Pair 3-
7	White / Brown	Ethernet (pair 4)	Bi-directional Pair 4+
8	Brown	Ethernet (pair 4)	Bi-directional Pair 4-
9	Not connected	Not connected	Not connected
10	Foil	Shield	Isolated from 0V

Power 3-pin connector

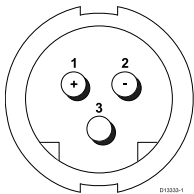

Power cable cores and colors

Signal	Pin	AWG	Color
(+) Positive	1	16	Red
(-) Negative	2	16	Black
Ground	3	26	Black

Note: Use only Raymarine **RayNet** cables when connecting **SeaTalk^{hs}** devices.

SeaTalk^{ng} connector

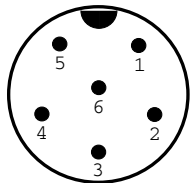

Item	Remarks
Identification	ST2/NMEA2000
Connector type	STNG
Current source to network	No current sourced for external devices
Current sink from network	<160mA (Interface drive only)

Pin	Signal
1	+12V
2	0V
3	Screen
4	CanH
5	CanL
6	SeaTalk (not connected)

Note: Use only Raymarine cables when connecting to SeaTalk^{ng}

Appendix B NMEA 0183 sentences

The display supports the following NMEA 0183 sentences. These are applicable to NMEA 0183 and SeaTalk protocols.

Sentence	Description	Transmit	Receive
AAM	Waypoint arrival alarm sentence		•
APB	Autopilot sentence 'B'	•	•
BWC	Bearing and distance to waypoint	•	•
BWR	Bearing and distance to waypoint — Rhumb	•	•
DBT	Depth below transducer	•	•
DPT	Depth	•	•
DSC	Digital selective calling information sentence		•
DSE	Distress sentence expansion		•
DTM	Datum reference sentence		•
GBS	GPS satellite fault detection data sentence		•
GGA	GPS System fix data	•	•
GLC	Geographic position loran C sentence		•
GLL	Geographic position latitude longitude	•	•
GSA	GPS DOP and active satellites	•	•
GSV	GPS satellites in view	•	•
HDG	Heading deviation and variation sentence		•
HDT	Heading true sentence		•
HDM	Heading magnetic sentence		•
MDA	Meteorological composite sentence		•
MSK	MSK receiver interface sentence		•
MSS	MSK receiver signal status sentence		•
MTW	Water temperature	•	•
MWV	Wind speed and angle	•	•
RMB	Recommended minimum navigation information	•	•
RMC	Recommended minimum specific GNSS data	•	•
RSD	Radar system data	•	•
TTM	Tracked target message	•	•
VHW	Water speed and heading	•	•
VLW	Distance travelled through the water	•	•
VTG	Course over ground and ground speed	•	•
XTE	Cross track error measured sentence		•
ZDA	Time and date	•	•

Appendix C NMEA data bridging

NMEA data bridging allows data that exists on the display's NMEA 2000 bus to be repeated to NMEA 0183 devices, and vice versa.

An example of NMEA data bridging is in a system that includes a third-party GPS receiver connected to the NMEA 0183 Input of a Raymarine display. The GPS data messages transmitted by the GPS receiver are repeated to any appropriate devices connected to the display's NMEA 2000 bus. Bridging only occurs when the data is being transmitted by an NMEA 0183 device that is not already being transmitted by a NMEA 2000 device, and vice versa.

For a list of data messages (PGN sentences) that are bridged between NMEA 2000 and NMEA 0183, refer to the list of supported NMEA 2000 sentences provided in this document.

Appendix D NMEA 2000 sentences

The display supports the following NMEA 2000 sentences. These are applicable to NMEA 2000, SeaTalk^{ng} and SeaTalk 2 protocols.

Message number	Message description	Transmit	Receive	Bridged to NMEA 0183
59392	ISO Acknowledgment	•	•	
59904	ISO Request	•	•	
60928	ISO Address Claim	•	•	
126208	NMEA - Request group function	•	•	
126464	PGN List – Receive / Transmit PGN's Group function	•	•	
126992	System time	•	•	
126996	Product information	•	•	
126998	Configuration information		•	
127237	Heading / Track Control		•	
127245	Rudder		•	
127250	Vessel heading	•	•	•
127251	Rate of Turn	•	•	
127257	Attitude	•	•	
127258	Magnetic Variation	•		
127488	Engine parameters, rapid update		•	
127489	Engine parameters, dynamic		•	
127493	Transmission parameters, dynamic		•	
127496	Trip parameters, Vessel		•	
127497	Trip parameters, Engine		•	
127498	Engine parameters, static		•	
127503	AC Input status		•	
127504	AC Output status		•	
127505	Fluid level		•	
127506	DC Detailed status		•	
127507	Charger Status		•	
127508	Battery status		•	
127509	Inverter status		•	
128259	Speed (water referenced)	•	•	•
128267	Water depth	•	•	•
128275	Distance log	•	•	•
129025	Position, rapid update	•	•	•
129026	COG and SOG, rapid update	•	•	•
129029	GNSS position data	•	•	•
129033	Time and date	•	•	•
129038	AIS Class A position report		•	
129039	AIS Class B position report		•	
129040	AIS Class B extended position report		•	
129041	AIS Aids to Navigation (AToN) report		•	
129044	Datum	•	•	•

Message number	Message description	Transmit	Receive	Bridged to NMEA 0183
129283	Cross track error	•	•	•
129284	Navigation data	•	•	•
129291	Set and drift, rapid update	•	•	•
129301	Time to or from mark		•	
129539	GNSS DOPs		•	
129540	GNSS Sats in view	•	•	
129542	GNSS pseudorange noise statistics	•	•	
129545	GNSS RAIM output		•	
129550	GNSS differential correction receiver interface		•	
129551	GNSS differential correction receiver signal		•	
129793	AIS UTC and date report		•	
129794	AIS Class A static and voyage related data		•	
129798	AIS SAR aircraft position report		•	
129801	AIS Addressed safety related message		•	
129802	AIS Safety related broadcast message		•	
129808	DSC call information		•	
129809	AIS class B "CS" static data report, part A		•	
129810	AIS class B "CS" static data report, part B		•	
130306	Wind data	•	•	•
130310	Environmental parameters	•	•	•
130311	Environmental parameters		•	•
130312	Temperature		•	
130313	Humidity		•	
130314	Actual pressure		•	
130576	Small craft status		•	
130577	Direction data	•	•	•
130578	Vessel speed components		•	

PGN 127489 - Support engine alarms

The following engine alarms are supported.

Engine Error
Check Engine
Over Temperature
Low Oil Pressure
Low Oil Level
Low Fuel Pressure
Low System Voltage
Low Coolant Level
Water Flow
Water in Fuel
Charge Indicator
High Boost Pressure
Rev Limit Exceeded

EGR System
Throttle Position Sensor
Engine Emergency Stop Mode
Warning Level 1
Warning Level 2
Power Reduction
Maintenance Needed
Engine Comm Error
Sub or Secondary Throttle
Neutral Start Protect
Engine Shutting Down
unknown error

Raymarine[®]
BY  **FLIR**[®]