

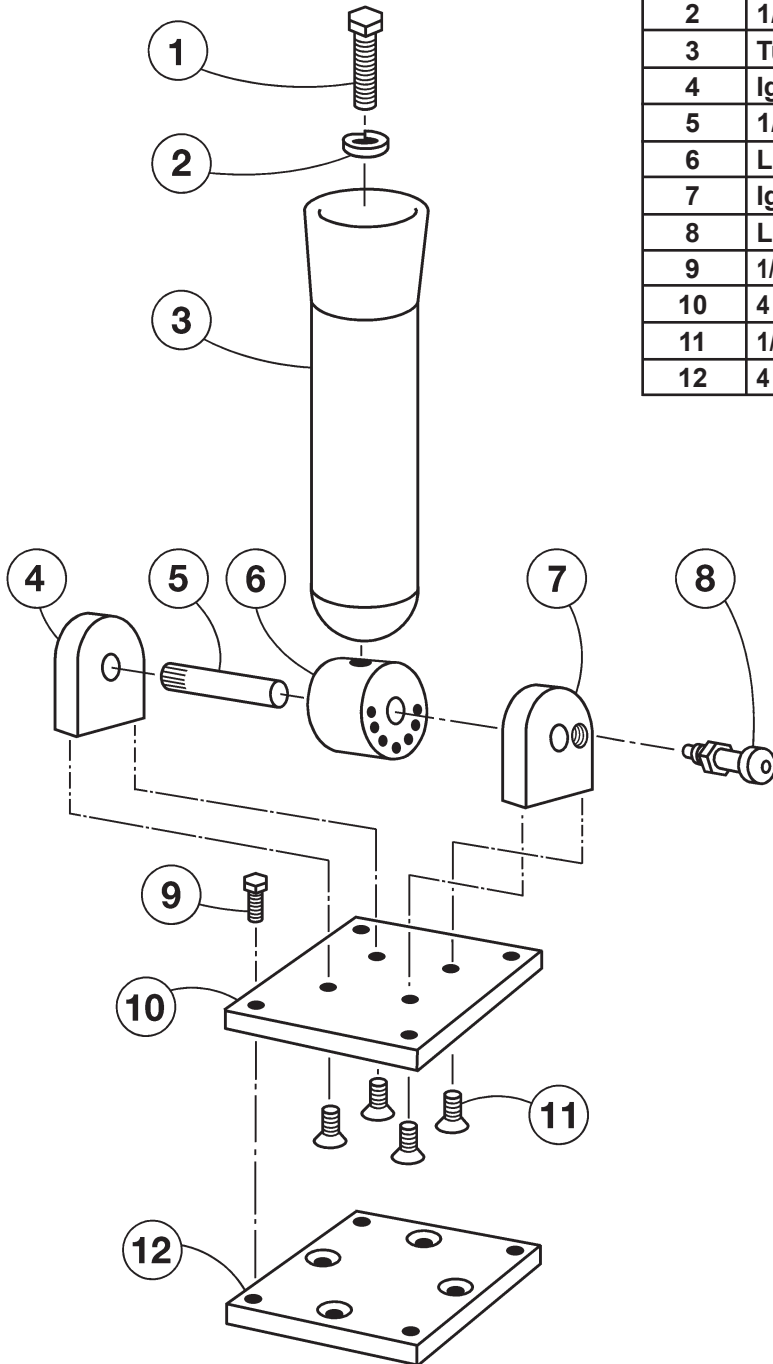

Heavy-Duty Deck Mount Rod Holder

Parts List RH00423

| Detail No. | Description | Qty. | Order By Part No. |
|------------|-----------------------------------|------|-------------------|
| 1 | 1/2-20 x 2 in. HHCS Bolt | 1 | 2351 |
| 2 | 1/2 in. Lock Washer | 1 | 2241 |
| 3 | Tube w/ Cap & Plug | 1 | 51221 |
| 4 | Igloo Upright B | 1 | 51258B |
| 5 | 1/2 x 3 in. Pivot Pin | 1 | 51254 |
| 6 | Locating Barrel | 1 | 51253 |
| 7 | Igloo Upright A | 1 | 51258A |
| 8 | Latch Pin Assembly | 1 | 51258 |
| 9 | 1/4-20 x 3/4 in. Hex Head Screws | 4 | 2017 |
| 10 | 4 x 4 in. Base Plate | 1 | 51256 |
| 11 | 1/4-20 x 3/4 in. Flat Head Screws | 4 | 2009 |
| 12 | 4 x 4 in. 8 Hole Mounting Plate | 1 | 51001 |



Mounting Instructions...

1. Make sure all wires below the mounting surface are clear of the area to be drilled.
2. Use the mounting channel as a template to locate and mark holes.
3. Drill the holes in the mounting surface and backing plate together.
4. Bolt the mounting base to the surface and backing board and secure with a flat washer and nut.

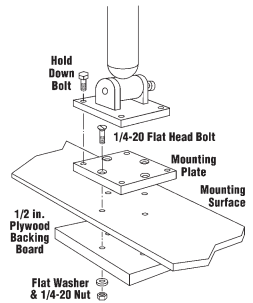

Operating Instructions...

1. While holding the rod holder tube, pull the latch pin out from the upright base.
2. Rotate the rod holder tube to any of the five locking positions in the cylinder at the base of the rod holder.
3. Release the latch pin and let it lock into the nearest locking hole in the cylinder at the base of the rod holder tube.

