

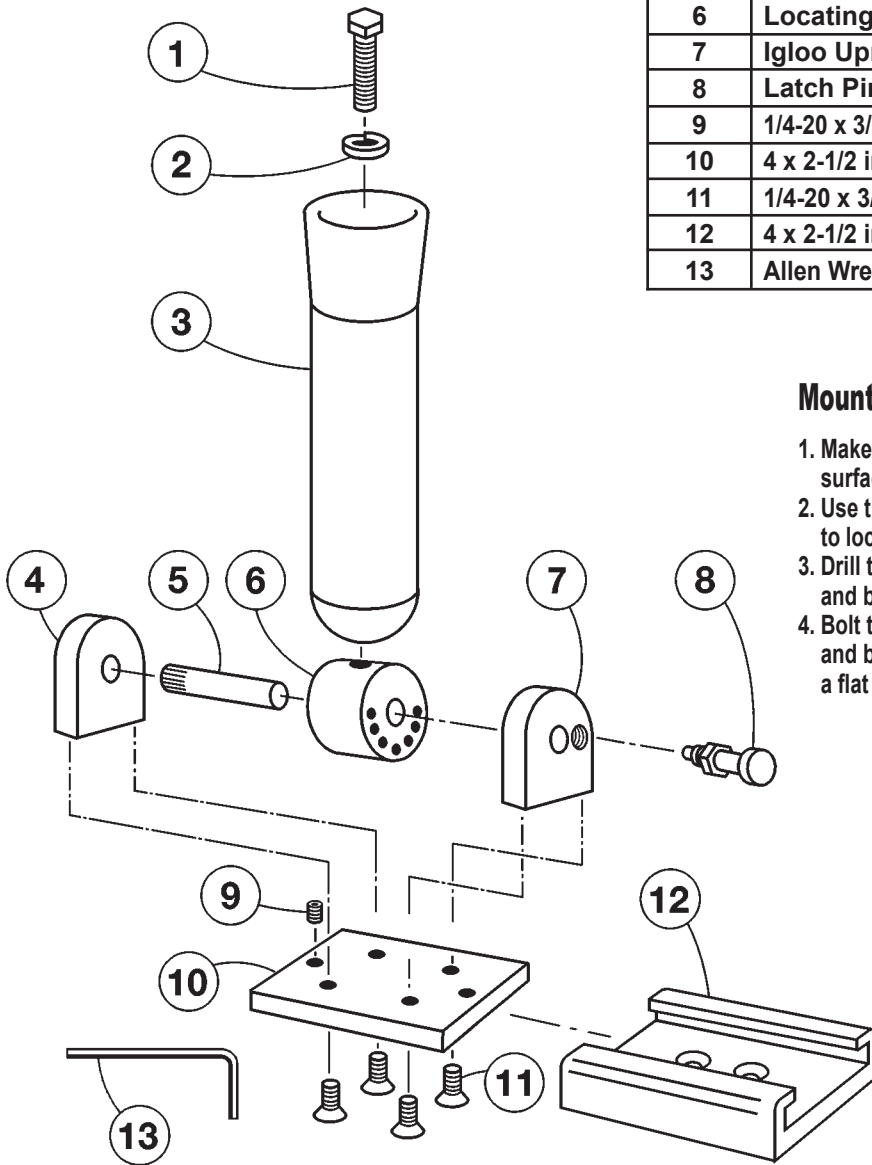

Heavy-Duty Deck Mount Rod Holder w/ Slim-Line Base

Parts List RH00424

Detail No.	Description	Qty.	Order By Part No.
1	1/2-20 x 2 in. HHCS Bolt	1	2351
2	1/2 in. Lock Washer	1	2241
3	Tube w/ Cap & Plug	1	51221
4	Igloo Upright B	1	51258B
5	1/2 x 3 in. Pivot Pin	1	51254
6	Locating Barrel	1	51253
7	Igloo Upright A	1	51258A
8	Latch Pin Assembly	1	51258
9	1/4-20 x 3/16 in. Set Screws	2	2261
10	4 x 2-1/2 in. Base Plate	1	55574
11	1/4-20 x 3/4 in. Flat Head Screws	4	2009
12	4 x 2-1/2 in. Mounting Track	1	55590
13	Allen Wrench	1	2260



Mounting Instructions...

1. Make sure all wires below the mounting surface are clear of the area to be drilled.
2. Use the mounting channel as a template to locate and mark holes.
3. Drill the holes in the mounting surface and backing plate together.
4. Bolt the mounting base to the surface and backing board and secure with a flat washer and nut.

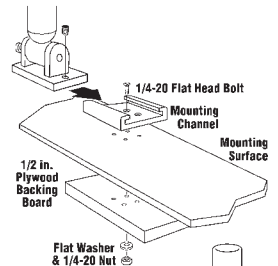

Operating Instructions...

1. While holding the rod holder tube, pull the latch pin out from the upright base.
2. Rotate the rod holder tube to any of the five locking positions in the cylinder at the base of the rod holder.
3. Release the latch pin and let it lock into the nearest locking hole in the cylinder at the base of the rod holder tube.

