



**One VHF Antenna,
Full Combination!**

Product Overview

CUBO-162 is AMEC's next generation AIS antenna splitter used to share a single VHF antenna for both VHF radio and AIS transponder or receiver. It provides also a feed for FM radio.

For optimized range of your VHF radio and AIS device, the splitter features zero insertion loss on reception path and ultra low insertion loss on transmission path. It's fail-safe feature guarantees priority to VHF radio operation even if the splitter is turned off. The built-in test function gives a simple diagnosis in the event of antenna problem.

Featured with durable design and compact housing, the CUBO-162 is the best companion of your AIS transponder.

Key Features

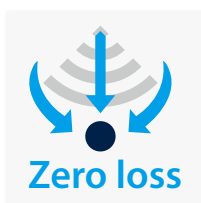

▶ Zero insertion loss for Reception
CUBO-162 provides optimized AIS and VHF radio performance in all situations.



▶ Fail-safe Operation
The guarantee of uninterrupted VHF/DSC radio operation even when the splitter is turned off.



▶ Low power consumption
Its advanced circuit design enables low power consumption by optimum performance.



▶ Self-test function
The error LED gives a simple diagnosis in the event of antenna problem.

Applications

- ▶ VHF Radio
- ▶ Recreation Boat
- ▶ AIS Transponder / Receiver
- ▶ VHF Antenna

DIMENSIONS

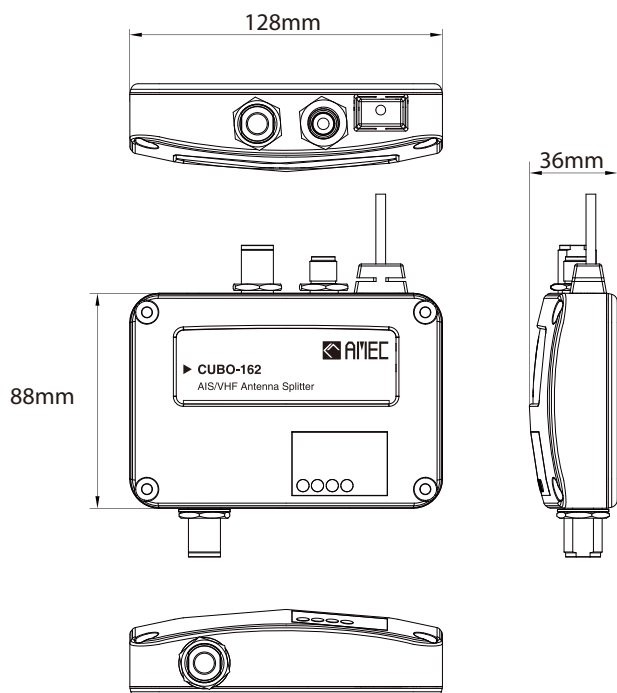

CONNECTION DIAGRAM

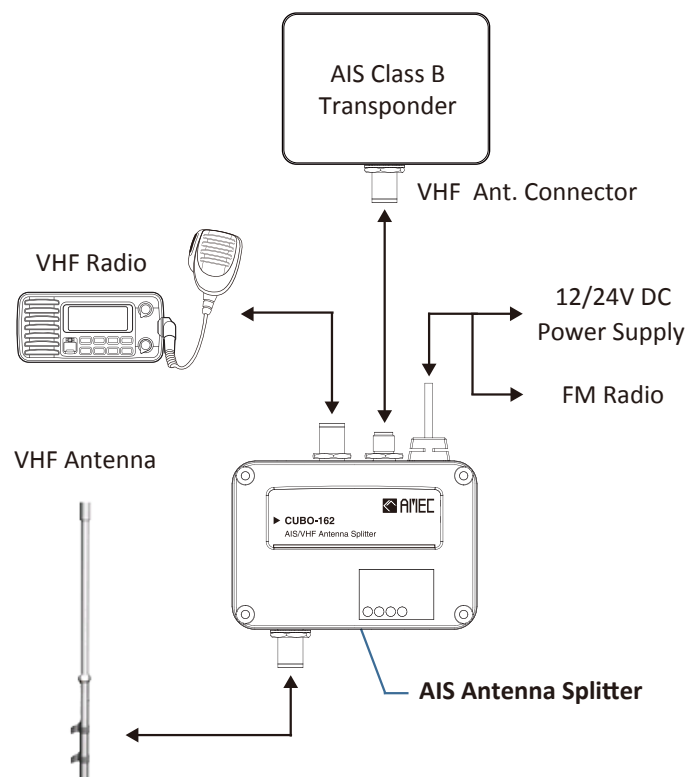

SPECIFICATIONS

RF PERFORMANCE

AIS & VHF Radio Frequency Range	156.025 MHz~162.025 MHz
Insertion loss, AIS Receive path	Typical 0dB
Insertion loss, VHF Radio Receive path	Typical 0dB
Insertion loss, AIS Transmit path	Typical 1dB
Insertion loss, VHF Radio Transmit path	Typical 1dB

POWER SUPPLY

Supply Voltage	12V ~ 24V DC
Operating current (receive)	100mA typical at 12VDC
Operating current (Transmit)	150mA typical at 12VDC

LED INDICATION

- One Power Indicator (Green)
- One Error Indicator (Red)
- One VHF Radio Transmission Indicator (Green)
- One AIS Transponder Transmission Indicator (Green)

PHYSICAL

Width	128 mm (4.99 inch)
Height	36 mm (1.40 inch)
Depth	88 mm (3.43 inch) (exclude connector)
Weight	230 g
AIS port	BNC : Max. 12.5W, 50Ω
VHF Radio port	SO-239 : Max. 25W, 50Ω
Antenna port	SO-239
FM Radio	Wiring connection

ENVIRONMENT

Operating Temperature	-15°C~55°C
Storage Temperature	-25°C~70°C
Operating Humidity	95% RH at 40°C
Waterproof	IPX2

Note: Specifications are subject to change without prior notice.



The AIS Specialists

Alltek Marine Electronics Corporation

14F-2, No. 237, Sec. 1, Datong Road, Xizhi District,
New Taipei City, 22161, Taiwan
Tel: +886 2 8691 8568 Fax: +886 2 8691 9569

Sales Contact

For more information, please contact your local representative or Alltek Marine at

sales@alltekmarine.com

www.alltekmarine.com

Distributor/Dealer