

**CLASS I, DIVISION 2 LED FIXTURE  
HAZARDOUS LOCATION LED FIXTURE**

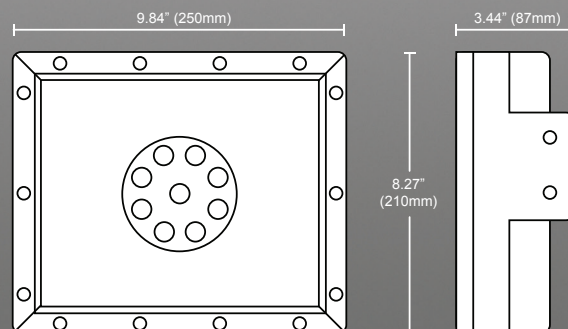

**LARGE AREA LIGHT**

LLB-60NC-31-10 &  
LLB-60NC-31-EX (Hazardous Certified)

The Lunasea 90W Flood Light produces the 11,500 lumens that really light up the work area. All this in a compact size with stainless brackets. Designed to project useful work area light that gets the job done. Designed to last! 100 degrees of ultra bright light that utilizes Lunasea’s proprietary thermal control electronics to guarantee long life in harsh temperatures and environments.

**APPLICATIONS**

Designed to efficiently light corrosive and Hazardous applications such as chemical, petrochemical, marine, power generation, pharmaceutical or food processing plants.

**SPECIFICATIONS**

- Voltage Range:** 90-305VAC, 50-60Hz, 127 - 431VDC
- Light Output:** 11,500 Lumen
- Beam Angle:** 100 Degree
- Operating Temp:** -40C - 70C
- Storage Temp:** -40C - 80C
- Color Temp:** Natural White, 4500K, 75 CRI
- LED:** Bridgelux, Cree, Phillips
- Environment:** IP65
- Enclosure:** Machined Marine Grade Aluminum
- Bracket:** 304 Stainless Steel
- Vent:** Gore Breather Valve
- Wiring:** 3 Wire
- Wire Length:** 6 Foot

**Listings**

- Conforms to UL Standards 844 for use in hazardous locations (tested by Imanna Labs)
- Conforms to UL Standards 1598 Wet Location & NFPA (tested by Imanna Labs)
- Class I, Division 2, Groups A, B, C & D; T-code of 6
- Meets USCG Requirements
- Outside Type (Salt Water)