

GBC014

For GB70

BOOST HD™ Protective Case



NOCO
Boost Accessories™

Rugged storage.

Protective EVA cases designed and made exclusively to fit Boost UltraSafe® Jump Starters.

The lightweight, durable, and rugged **GBC014** EVA Protective Case has a semi-rigid custom exterior with zipper closures and a reinforced handle. The rubberized EVA exterior offers protection from moisture, impact, dust, and other environmental factors, while the molded interior perfectly fits, stores, and protects its corresponding NOCO Genius® Boost jump starter.



Made of thermoformed EVA, the lightweight and durable molded exterior has a water resistant, rubber-like finish.

Heavy-duty reverse coil zipper with built-in reinforced handle and custom over-molded pull tab.



Boost insert molded tray interior with soft black melange velvet lining for secure fit.

Reinforced pockets for securely holding clamps, extensions or other accessories.



For **GB70** BOOST HD UltraSafe® Jump Starter

The NOCO Company
30339 Diamond Parkway, #102
Glenwillow, OH 44139 | USA
1.800.456.6626

no.co

NOCO
Since 1914

GBC014

Accessory Pockets

Fits Additional
Accessories

Fits
GB70 BOOST HD™

*Boost & Accessories
Not Included.

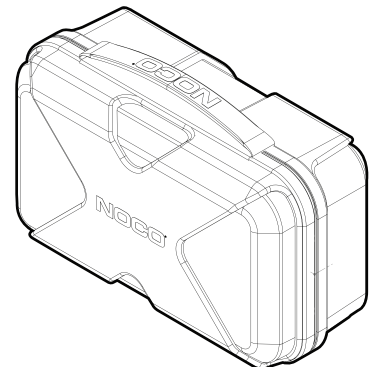
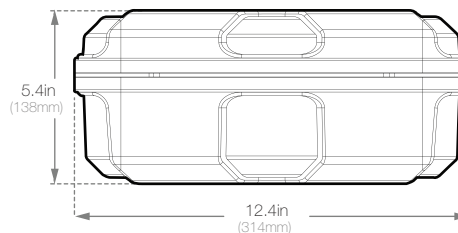
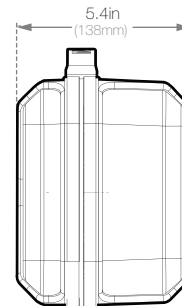
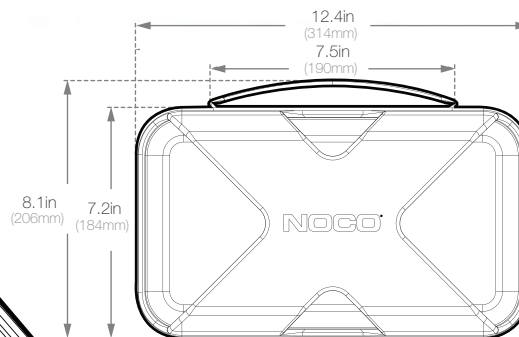

Retail Packaging:
Dimensions: 12.4"x8.1"x5.4"
Weight: 1.4lbs
UPC: 0-46221-17028-3
Inner Carton:
Dimensions: 12.4"x8.1"x5.4"
Weight: 1.7lbs

Master Carton:
Dimensions: 16.4"x12.7"x11.3"
Weight: 8.3lbs
Quantity: 4
UCC: 10046221170280
Units Per Pallet: 180 Units

The NOCO Company
30339 Diamond Parkway, #102
Glenwillow, OH 44139 | USA
1.800.456.6626

no.co

NOCO[®]
Since 1914