

200-024 – 2NM 180° WHITE LIGHT

The LED light consists of a single array of LEDs that produces light in the specified angle.

The precision machined 6082 aluminium housing with a hard coated anodized surface makes the light a rugged and durable housing for the LEDs and electronics contained within, and the polished PMMA lens delivers a clear light with colour ranging that is well within the standard for maritime use.

Lastly all the interior is completely filled with a special potting resin making it water- and vibration proof before each light is subjected to final testing for no less than 16 hours of continuous operation bringing the total test period beyond 24 hours.

Lopolight products are covered by a 5-year limited warranty. This warranty covers direct exchange of the malfunctioning product and is given under the assumption that the lights have been operated within the specifications of lights.

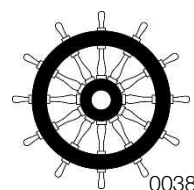

Technical specifications

Vessel size: <50m (<164')

Visibility: >2 nautical miles

Intensity: >5,4 cd

Mounting: **Vertical**

Operating voltage: 10 - 32 V DC

Number of LEDs: 12

Light colour: **White**

Operating temperature: -25°C to +55°C

IP Rating: **IP68**

Power consumption; 2,4 Watt; Current @ 12 VDC: 0,2A - Current @ 24 VDC: 0,1A

Connection: 1 cable consisting of 2 x 0,5 mm² leads, a screen and insulation.

- Red lead = Power
- Black lead = GND

Certification: The product is certified by Lloyds (LR) and certificates can be found on www.lopolight.com under certificates.

Approvals: COLREG72 / EN14744 / IEC 60945 / USCG / UL1104

Dimensions: **See drawing**

Weight: **0,18kg**

Included in the package:

- 1 Navigation light, pre-cabled with 0,75m marine grade cable
- 1 Mounting adaptor
- Installation instructions

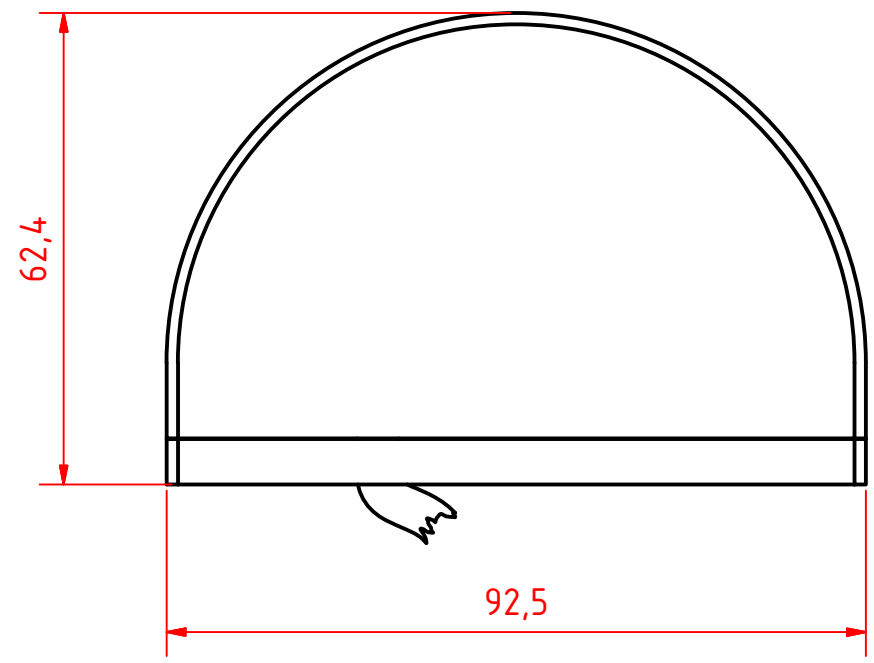

Mounting Instructions:

- Remove the two DIN 912 screws on the top side of the assembly, thus releasing the navigation light from its mounting bracket.
- Drill the holes for the machine screws and the cable as shown on the measurements. Thread the screw mounting holes if applicable to the specific situation.
- Mount the mounting bracket onto the super structure using two 6m countersunk machine screws. Make sure that the surface is flat and vertical.
- Resassemble the Navigation light

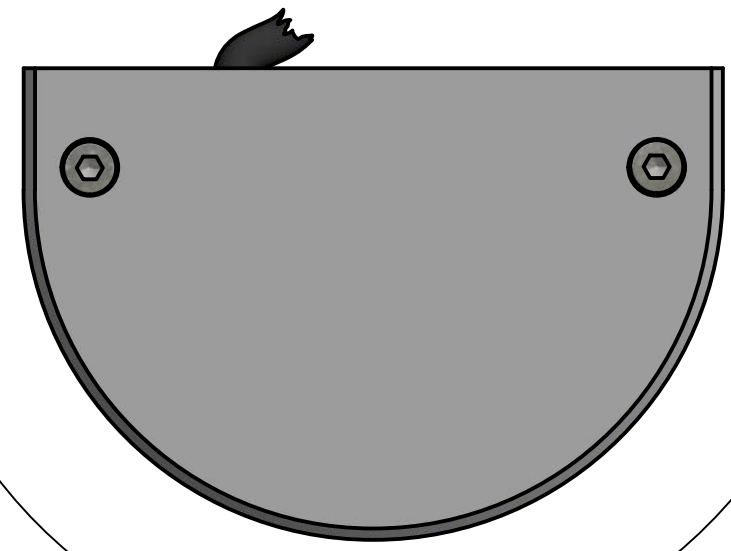
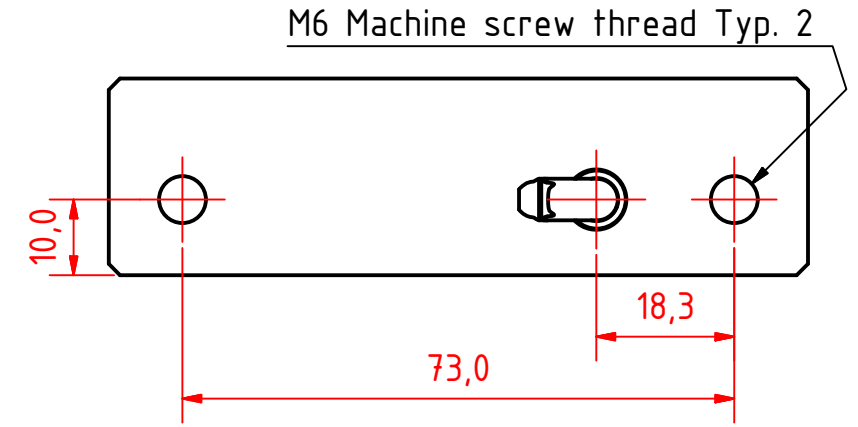
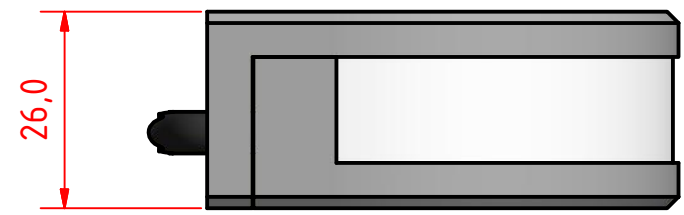
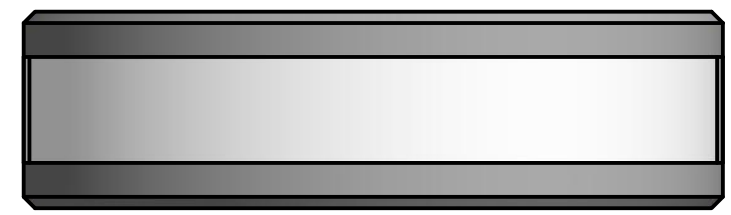
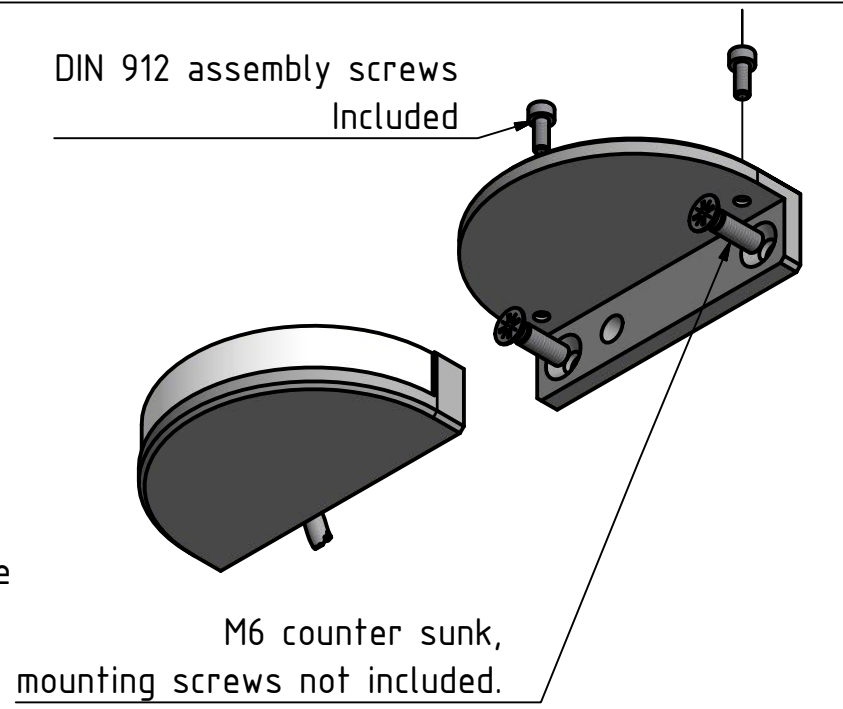

180 deg. White

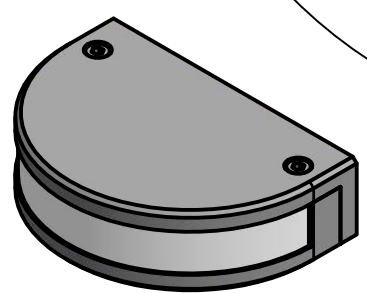

50MM AT A3

200-024 180 degree White, 2 Nautical Mile

DRAWING NO.: 200-024AA	REV. NO.: 0	SIZE: A3	DRAWN BY: Paul
SCALE: 1:1	TOLERANCES: DS/ISO 2768-f	REVIEWED BY: JM	

MATERIAL DESCRIPTION:
Anodized Aluminium & Acrylic Glass

This Drawing, and the information within, is the property of Lopolight ApS and may not be used in any form without express permission there from. Lopolight reserves the right to change this drawing and assumes no liability for the information communicated herein. Use of dimensions and other information in this drawing is at the users own risk.



Lopolight ApS
Ved Klaedebo 12
DK-2970, Hoersholm
Denmark

www.lopolight.com

Tel:(+45) 32 48 50 30 Fax:(+45) 32 48 50 32
info@lopolight.com