

8 7 6 5 4 3 2 1

D

C

B

A

D

C

B

A

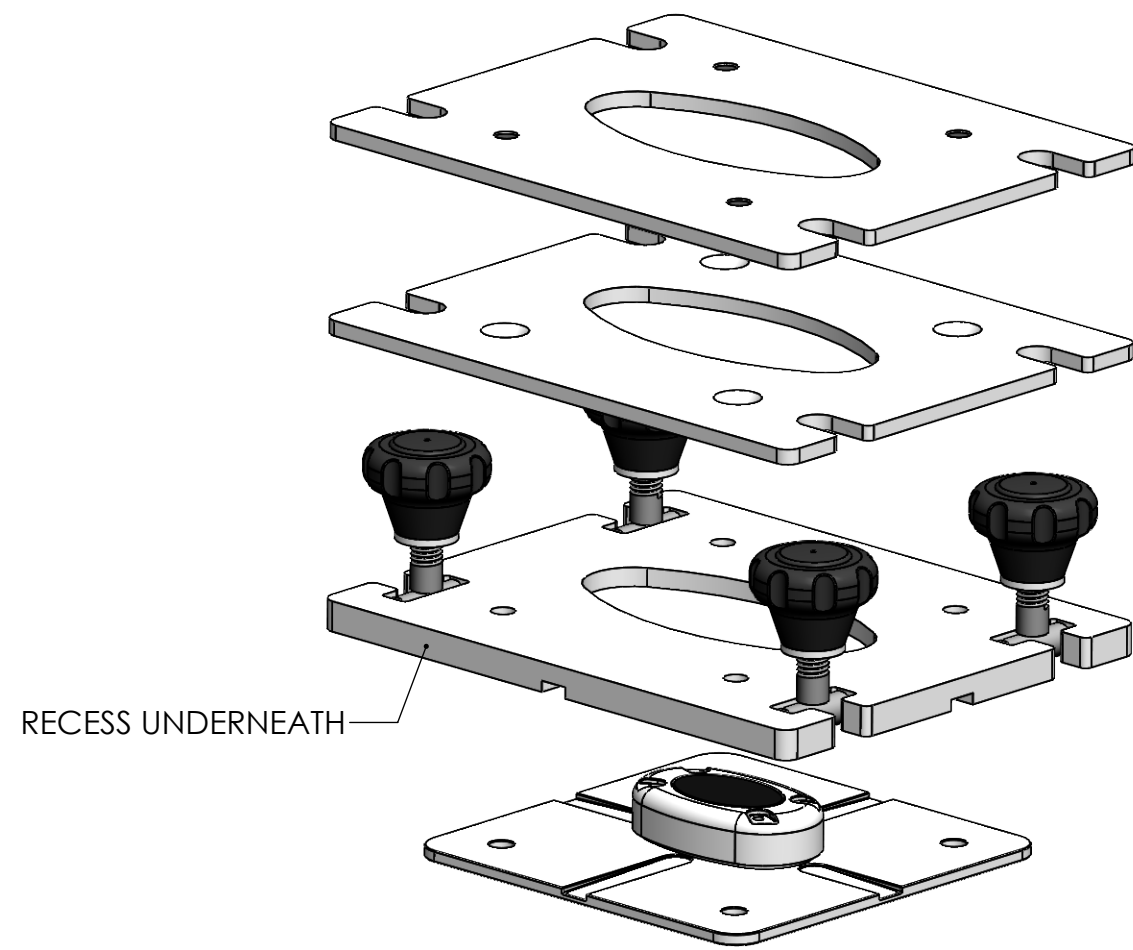

EXPLODED

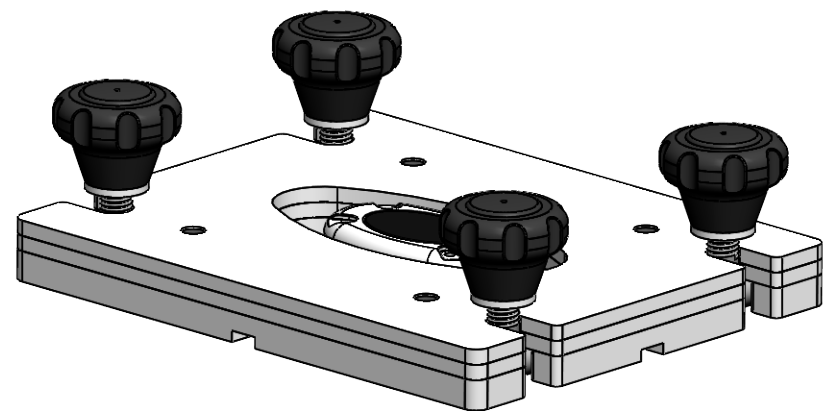

COLLAPSED

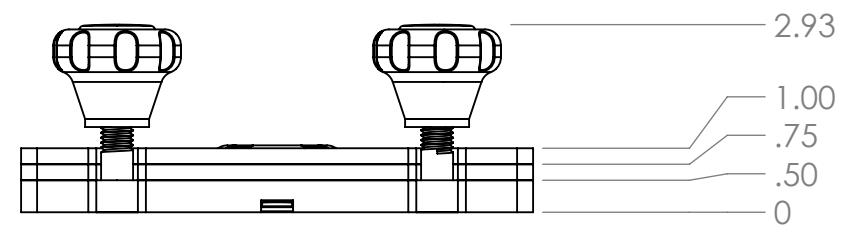
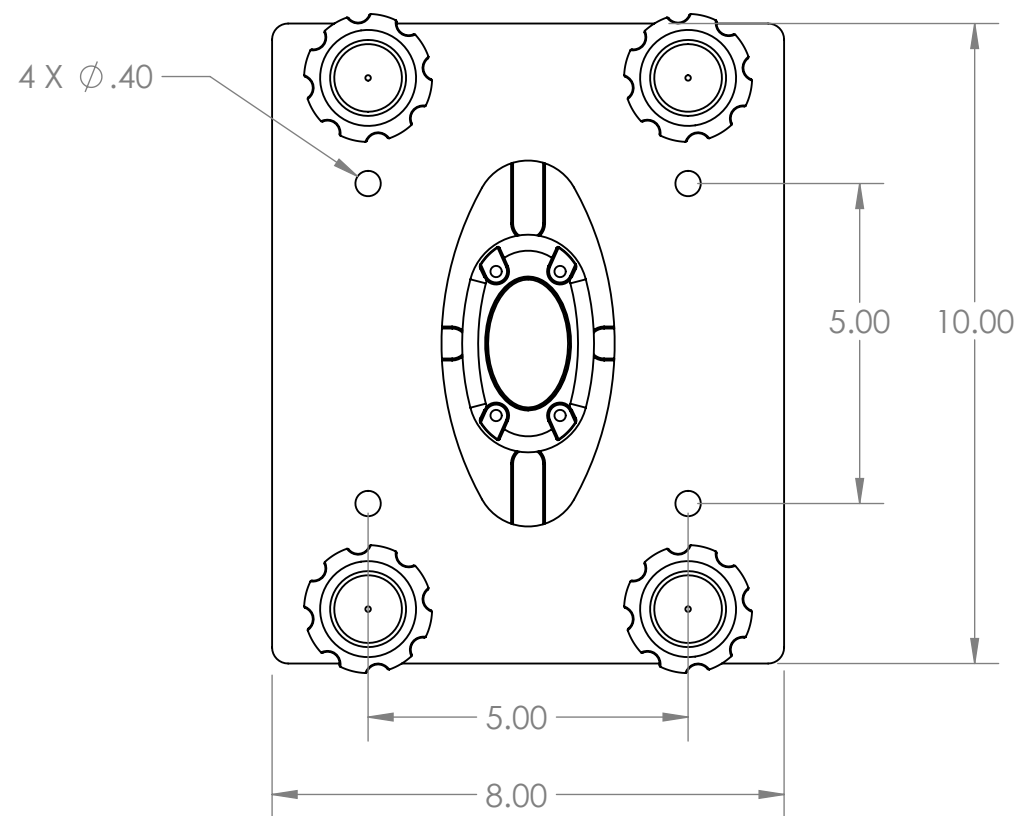

<p>PROPRIETARY AND CONFIDENTIAL THE INFORMATION CONTAINED IN THIS DRAWING IS THE SOLE PROPERTY OF SEAVIEW. ANY REPRODUCTION IN PART OR AS A WHOLE WITHOUT THE WRITTEN PERMISSION OF SEAVIEW IS PROHIBITED.</p>	<p>UNLESS OTHERWISE SPECIFIED: DIMENSIONS ARE IN INCHES</p>	<table border="1"> <tr> <td>NAME</td> <td>DATE</td> </tr> <tr> <td>S.C.</td> <td>10.23.23</td> </tr> </table>	NAME	DATE	S.C.	10.23.23							
	NAME	DATE											
	S.C.	10.23.23											
	<p>TOLERANCES: X.XX = ± 0.01 X.XXX = ± 0.003 ANGLES = ± 0.5°</p>	<table border="1"> <tr> <td>DRAWN BY:</td> <td>--</td> </tr> <tr> <td>ENGINEERED BY:</td> <td>--</td> </tr> <tr> <td>CUSTOMER:</td> <td>--</td> </tr> </table>	DRAWN BY:	--	ENGINEERED BY:	--	CUSTOMER:	--	<p>PMRB7</p>				
DRAWN BY:	--												
ENGINEERED BY:	--												
CUSTOMER:	--												
<p>THIRD ANGLE PROJECTION</p>	<p>INTERPRET GEOMETRIC TOLERANCING PER: ASME Y14.5</p> <table border="1"> <tr> <td>MATERIAL</td> <td>--</td> </tr> <tr> <td>FINISH</td> <td>--</td> </tr> </table>	MATERIAL	--	FINISH	--	<p>COMMENTS: -LIMITED DIMENSION DRAWING (TO MAINTAIN DRAWING CLARITY)</p>	<table border="1"> <tr> <td>SIZE</td> <td>DWG. NO.</td> <td>REV</td> </tr> <tr> <td>B</td> <td>PMRB7-DWG</td> <td>2</td> </tr> </table>	SIZE	DWG. NO.	REV	B	PMRB7-DWG	2
MATERIAL	--												
FINISH	--												
SIZE	DWG. NO.	REV											
B	PMRB7-DWG	2											
		<p>SCALE: 1:3 WEIGHT:</p>	<p>SHEET 1 OF 1</p>										

8 7 6 5 4 3 2 1