

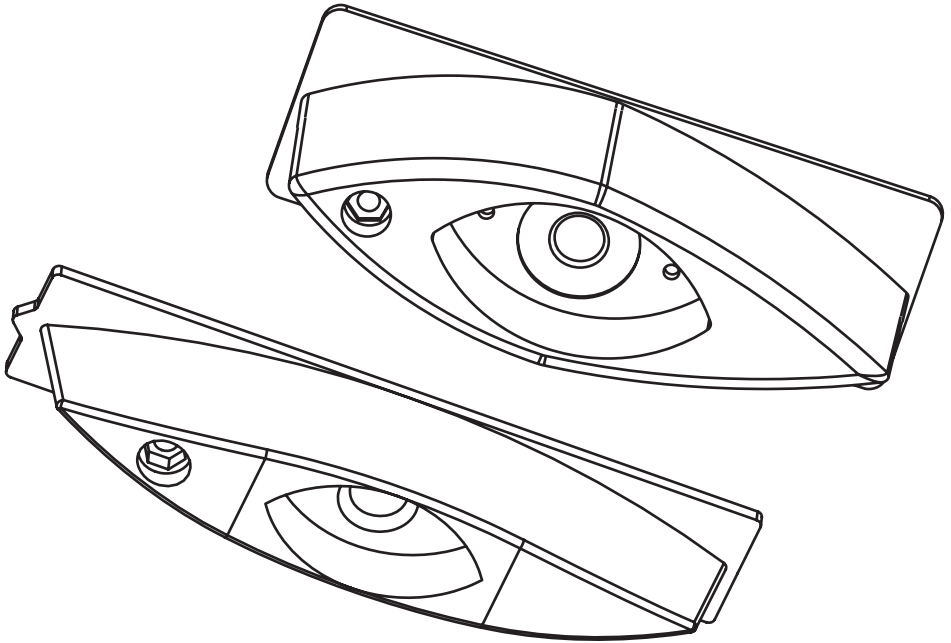

MMFBENA011

**Echonautics**®  
soundwave innovation



# High Performance Fairing Block

CB101xxx / CB131xxx series

**WARNING AND INSTALLATION MANUAL**

# 1. Warranty and Warnings

---

AvMap Srl warrants every unit to be free from defects in material and workmanship under normal use and service for a period of 36 months from original retail purchase. During the warranty period, AvMap Srl will repair or replace any component which fails in normal use without charges for parts or labour. Technological developments, modifications and upgrades of software are not covered by warranty (except commercial decision). To receive warranty service, contact your local authorized dealer for shipping instructions. The product should be securely packed with its tracking code clearly written on the outside of the package, shipping to be paid by the customer. Include a copy of the original sales receipt as the proof of purchase. This limited warranty does not extend to any product which has been subjected to misuse, neglect, accident, incorrect wiring or improper installation. AvMap Srl reserves the right to repair or replace the device at its sole discretion.

For more warranty information please see the website: [www.avmap.it](http://www.avmap.it)

For technical advice or assistance contact:

**North America:**

AvMap Satellite Navigation Inc  
25 Enterprise Zone Drive,  
Riverhead, NY 11901, USA  
+1 800 363 26 27  
[info@avmap.us](mailto:info@avmap.us)

**EMEA, APAC:**

AvMap Srl  
Viale Zaccagna 6,  
54033, Carrara (MS), Italy  
+39 0585 784044  
[support@avmap.it](mailto:support@avmap.it)

**IMPORTANT:** Use the instructions of this installation manual along with the transducer installation manual. The instructions of this installation manual supersede all other instructions where they differ.

**IMPORTANT:** Please read this installation manual completely before first operation and follow the precautions and instructions for the highest performance of the transducer and to reduce the risk of property damage or personal injury. If you have any questions, please contact customer service or your local dealer.

**WARNING:** It is mandatory to install the fairing block with the anti-rotation bolt (included). Failure to do so could result in the fairing block rotating while the vessel is moving and could cause damage to the vessel. The effect may be violent movement and loss of steering. This could result in serious injury or death to passengers and/or damage to the vessel or other property. The anti-rotation bolt holds the fairing block firmly in place.

**WARNING:** Always wear proper safety gear during installation.

**WARNING:** The fairing block must be installed parallel to the keel to ensure proper vessel handling and operation.

**WARNING:** Do not install a fairing block that has been miscut. Replace it with another fairing block.

**WARNING:** Respect the maximum indicated cutting angle of the fairing block. Exceeding the maximum cutting angle will weaken the fairing block.

**WARNING:** Do not allow any gap greater than 3mm (1/8") between the fairing block and the vessels hull. Water may enter any gaps when the vessel is underway and push against the fairing block with considerable force loosening or possibly rotating it.

**CAUTION:** Do not over-tighten the hull nut and nut on the anti-rotation bolt. Over-tightening the nut can crush and damage the fairing block and/or hull.

**CAUTION:** The transducer and the round tap that covers the anti-rotation bolt must be flush with the fairing block for smooth water flow under the transducer.

**CAUTION:** Never use solvents. Cleaners, fuel, sealant, paint and other products may contain solvents that can attack the fairing block material and reduce its strength.

## **2. Product description**

---

Echonautics fairing blocks are made for thru-hull installation of traditional stem transducers. A fairing block is recommended for installation of any traditional stem transducers to the vessels hull to protect the transducer and guarantee excellent performance while the vessel is underway. The fairing block helps to ensure a bubble free flow of water across the face of transducer.

Fairing blocks are required for the transducer to match deadrise angle at vessels mounting location. The fairing block is used to match deadrise angle by orienting the transducers sound beam straight down by mounting the transducer parallel to the water surface.

Echonautics high performance fairing blocks are made of high-impact polymer and designed for excellent transducer performance even at speeds above 15kn (17MPH).

For more product details go to website [www.echonautics.com](http://www.echonautics.com)

### **2.1 Content of the package**

- High Performance Fairing Block model CB101 / CB131;
- Anti-rotation bolt with nut, washer and round tap;
- Warning & Installation manual.

## **3. Pre-installation**

---

### **3.1 Tools and materials needed**

- Safety glasses;
- Dust mask;
- Ear protection;
- Angle finder;
- Sandpaper;
- Masking tape;
- Waterproof electrical tape;
- Drill;
- 3 mm (1/8") drill bit;
- Hole saw;
- Adjustable wrench;
- Marine sealant (suitable for below waterline);
- Mild household detergent or rubbing alcohol;
- Grommets (optional);
- Water-based anti-fouling paint (mandatory in salt water);
- Cable ties;
- Slip-joint pliers;
- Bandsaw or table saw (sharp blade);
- Rasp or power tool.

Additional items are needed for mounting in a fiberglass hull:

- Hole saw for hull interior;
- Marine grade epoxy resin for fiberglass (cored fiberglass hulls);

### 3.2 Identify your fairing block model

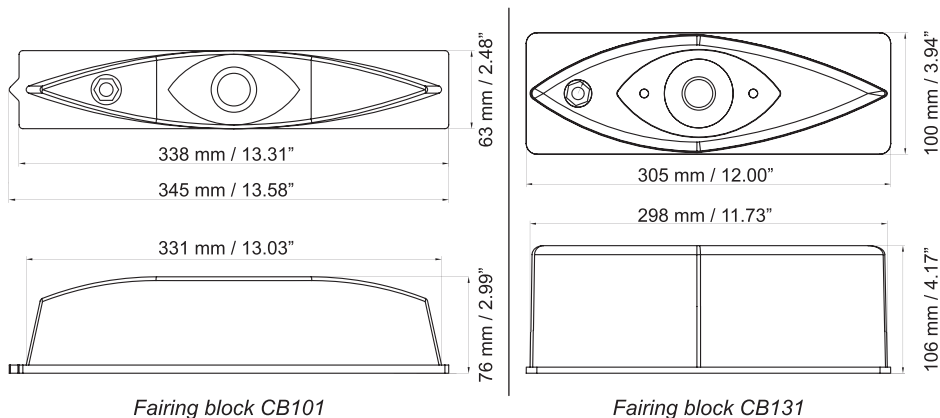

Fairing block model	Transducer model	Max. deadrise / cutting angle	Min. Fairing thickness	Hull hole saw size for transducer	Hull hole saw size for anti-rotation bolt
CB101	CB101xxx series	26°	35 mm / 1.38"	25 mm / 0.98"	11 mm / 0,43"
CB131	CB131xxx series	24°	51 mm / 2.00"	25 mm / 0.98"	11 mm / 0,43"

Table 3.2 - Cutting and hole saw size indications

### 3.3 Cutting the fairing block

**IMPORTANT:** Respect the minimum thickness for the fairing at its thinnest dimension (see table 3.2 and figure 3.3).

**IMPORTANT:** Fairing block deadrise/cutting angle must not exceed the maximum allowed angle (see table 3.2 and figure 3.3).

**WARNING:** Make sure that the anti-rotation bolt points forward to the bow when installed.

**WARNING:** Always wear proper safety gear during installation.

**WARNING:** Do not allow any gap greater than 3mm (1/8") between the fairing block and the vessels hull. Shape the fairing, with a rasp or power tool, to match the hull as precise as possible. Water may enter any gaps when the vessel is underway and push against the fairing block with considerable force loosening or possibly rotating it.

**WARNING:** The transducer must be flush with the fairing. If it is recessed more than 0.5mm (1/64") inside the fairing, you may carefully shim the transducer slightly or carefully file/sand the fairing.

Once you have identified the best location for installation (see the transducers Warning and Installation Manual), verify that you have sufficient room to tighten the mounting hardware from inside the hull. Measure at the identified location for installation the deadrise angle of the vessels hull using an angle finder and cut the fairing block to match (a band saw with sharp blade is recommended for cutting the fairing block).

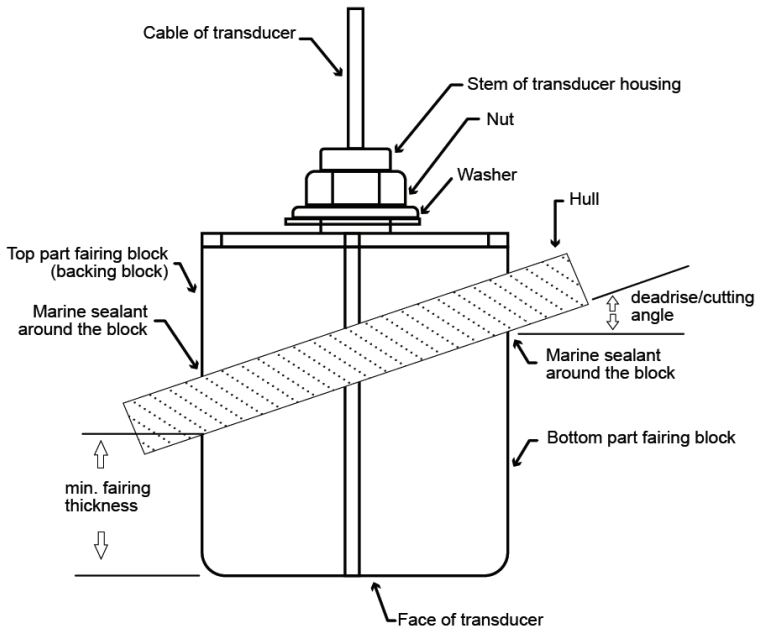

Figure 3.3 - Installation indications and measurements references

Make sure to place the fairing on the band saw in the right orientation so the angle cut matches the intended hull side and not the mirror image.

Cut the fairing in two parts. After cutting you will have the top part (backing block) and bottom part (the part the transducer fits in).

## 4. Installation of the transducer with fairing block

**WARNING:** The anti-rotation bolt must always be installed with the fairing block to prevent catastrophic failure and damage to both the boat and the transducer.

**WARNING:** Ensure that the fairing block and transducer are pointing straight downward, permitting the transducer to operate correctly. Be sure to identify the top part (backing block) versus the bottom part of the cut fairing block.

**WARNING:** The fairing block must be installed parallel to the keel to ensure proper vessel handling and operation.

**WARNING:** Make sure that the anti-rotation bolt points forward to the bow when installed.

**WARNING:** Installation on any hull, and especially on cored fiberglass, should be performed by a trained technician. If not installed properly it can lead to water leakage and/or premature hull failure.

### STEP 1: Transducer hole drilling

**IMPORTANT:** Check the hull hole saw dimensions for the transducer on table 3.2.

1. Drill a small 3mm / 1/8" hole from inside the hull where you want to place the transducer, positioning at the center of the intended transducer location. This hole will be the reference hole for external drilling.

2. From the outside enlarge the location hole to 6mm / 1/4" or whatever size needed for the pilot drill of the hole saw (see table 3.2). Drill the pilot hole vertically, followed by the hole saw.
3. When you finish drilling remove rough edges around the hole and completely clean and sand the inside and outside surfaces around the hole. If there is any petroleum residue inside the hull, remove it with either mild household detergent or rubbing alcohol before sanding.

## **STEP 2: Fairing block anti-rotation bolt hole drilling**

**IMPORTANT:** Check the hull hole saw dimensions for the anti-rotation bolt on the table 3.2.

1. Take nut off the transducer housing.
2. Place the bottom part of the fairing block in the location of the hole that was drilled for the transducer stem. Run the transducer cable through the fairing block and the hole in the hull and place the transducer into the fairing block. Make sure both the fairing block and transducer fit tightly against the hull and that the fairing block is vertically straight. The long side of the transducer must be parallel to the centerline of the vessel.
3. Hold the fairing block and transducer tightly against the hull, making sure the fairing block is vertical and straight so water will flow over it, and that the anti-rotation bolt hole is facing forward. With a pencil, trace around the fairing block on the hull and mark the position of the anti-rotation bolt hole through the actual hole itself. Remove the transducer from the fairing block and lower the block.
4. Drill a small 3mm / 1/8" hole for the anti-rotation bolt. This hole will be the reference hole. Enlarge the location hole to 6mm / 1/4" or whatever size needed for the pilot drill of the anti-rotation bolt hole (see table 3.2). Drill the pilot hole vertically, followed by the hole saw.
5. When you finish drilling remove rough edges around the hole and completely clean and sand the inside and outside surfaces around the hole. If there is any petroleum residue inside the hull, remove it with either mild household detergent or rubbing alcohol before sanding.

## **STEP 3: Mounting the transducer and fairing**

1. Inside the hull, correctly position the top part (backing block) of the fairing block with reference to the transducer stem hole and the forward-facing anti-rotation bolt hole. Trace around the block on the inside of the hull as reference for proper alignment and reference for applying the marine sealant.
2. On the outside of the hull apply a good amount (approximately 2mm / 1/16" thick) of a marine sealant/ adhesive compound around the entire base of the fairing block. Put a small bead of sealant around the trace area on the hull and pay close attention to applying a generous amount around the drilled hole area.
3. Put a good amount (approximately 2mm / 1/16" thick) of a marine sealant/ adhesive compound on the inside of the fairings pocket area where the transducer will sit. Put a good amount (approximately 2mm / 1/16" thick) of a marine sealant/ adhesive compound around the stem of the transducer that touches the fairing. The sealant/ adhesive compound should extend up the side wall of the housing, about 6mm / 1/4" higher than the combined thickness of the fairing, hull, backing block and hull nut (and washer/spacer when used). This will make sure there is sealant in the threads to seal the hull and to keep the hull nut secured.
4. Insert the transducer into the fairing block, passing the cable through the block. Properly position the fairing block with the transducer and hold them in place against the hull. On the inside of the hull put a bead of sealant around the trace area, and all along the section of the top part of the fairing (backing block). Pay close attention around the holes on the inside of the hull. Pass the cable through the hole of the top part of the fairing block, and pass the transducer nut along the cable to the stem. Slowly tighten down the stem nut, but not fully yet.

5. Put a good amount (approximately 2mm / 1/16" thick) of a marine sealant/ adhesive compound around the anti-rotation bolt including the flange. The sealant/ adhesive compound should be about 6mm / 1/4" higher than the combined thickness of the fairing, hull, backing block and hull nut (and washer/spacer when used). This will make sure there is sealant in the threads to seal the hull and to keep the hull nut secured.
6. Put a good amount (approximately 2mm / 1/16" thick) of marine sealant/ adhesive compound to the side of the washer (if used) that contacts the backing block.
7. Pass the anti-rotation bolt through the fairing block and tighten down its nut from inside the hull. Slowly tighten down both the transducer nut and anti-rotation bolt nut until both are snug. Do not over-tighten.
8. Take the round tap that will cover the anti-rotation bolt. Fill the round tap with a good amount of a marine sealant/ adhesive compound and put a good amount (approximately 2mm / 1/16" thick) of the sealant on the sides of the round tap. Make sure the sealant fills any gap between the anti-rotation bolt and the round tap. The sealant holds the round tap firmly within the fairing.
9. Push the round tap into the recess in the fairing. Excess sealant will be squeezed out while placing the round tap. Make sure the round tap is FLUSH with the outside of the fairing and if necessary, tap it into place using a mallet.

**IMPORTANT:** If the round tap is slightly recessed within the fairing, use a marine sealant/ adhesive compound to fill the gap. The round tap must be FLUSH with the fairing for good performance.

10. Remove any excess sealant on the outside of the hull to make sure there is a smooth water flow over the face of the transducer.

**WARNING:** Do not use solvents on the face of transducer. Solvents will damage the transducer.

**IMPORTANT:** Remember to allow sealant to set before putting the boat back in the water, and to monitor for leakage for at least 3 hours afterwards.

## 5. Checking for leaks

---

After installing a thru hull transducer and fairing block do not leave the boat unattended for several days. After the adhesive/sealants has setup correctly, place the vessel in the water and check around for leaks immediately. Small leaks may not be immediately seen. The vessel should not be left in the water for more than 3 hours without checking for leaks. If there is a leak, repeat the mounting installation procedure of chapter 4 step 3.

## 6. Maintenance

---

### 6.1 Anti-fouling paint

Surfaces exposed to salt water must be coated with anti-fouling paint. Water-based anti-fouling paint should be applied to the hull of your vessel every six months or at the beginning of each boating season.

**IMPORTANT:** Use water-based anti-fouling paint only.

**CAUTION:** Never use ketone-based paint, because ketones attack many types of plastic and could damage the transducer.

## **6.2 Cleaning the transducer**

Aquatic fouling accumulates quickly on the transducers surface and can reduce its performance. Remove the fouling with a soft cloth and mild detergent. If the fouling is severe, use a non-metallic scouring pad to remove growth. Wipe the transducer dry.

**IMPORTANT:** To prevent permanent damage to the surface of the transducer, do not use solvents such as mineral spirits, acetone, Methyl Ethyl Ketone (MEK), or similar products when cleaning. Do not use a power sander or pressure washer to clean the transducer.

**CAUTION:** To avoid possible transducer damage or personal injury, use care when cleaning the transducer, particularly when attempting to remove severe fouling.

## **7. Safety information**

---

AvMap disclaims any liability deriving from an improper use or installation of the product in a way that may violate the regulations and safety. It is highly recommended that the installation of the product be performed by a qualified maintenance technician. Consult the Installation manual for a correct installation procedure.

AvMap Srl  
Viale Zaccagna 6,  
54033 Carrara (MS), Italy  
support@avmap.it



[www.echonautics.com](http://www.echonautics.com)