

Specifications

Placement

Passenger side on the floor, in front seat.

Seat Configuration

Bucket

Drilling Required

None - uses existing seat bolts.

Construction/Finish

Steel/Black powder coat

Dimensions

(A) 15" (B) 8" (C) 1"

(Hole Center) 11.5" - 12"

Pole or Pedestal

Purchased separately

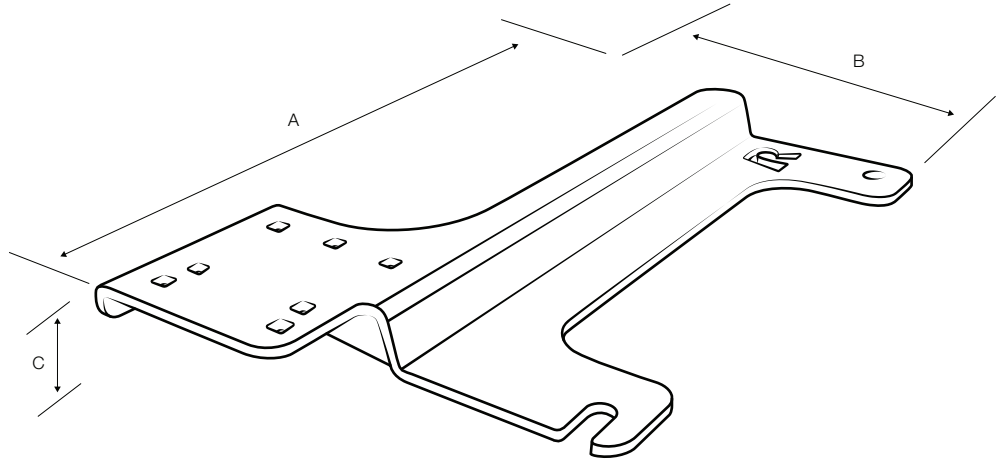

Important Note

Utilizes existing vehicle hardware. Plastic trim will not be re-installed once the RAM® No-Drill™ base has been secured into vehicle.

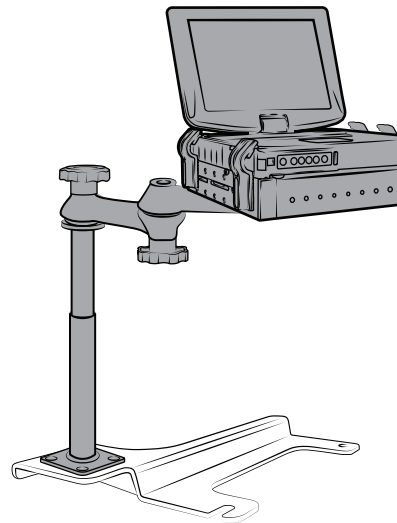

RMR-INS-VB-202-A



Safety Precaution

Do not install this product near or over an airbag deployment area or in a location that obstructs the driver's vision or interferes with vehicle operation. National Products, Inc does not assume responsibility or liability for any such personal injury, death or property damage.

Installation Instructions

If installing this base with a RAM® Tele-Pole™ assembly, attach the lower female pole prior to installing the RAM® No-Drill™ base. The carriage bolts should come up through the bottom with the rubber caps on the top side covering the nuts once attachment is complete.

- 1 Move the passenger seat to its rearmost position.
- 2 Remove the two square caps covering the seat mount bolts. Insert fingers towards the back and curl finger up to pop caps up.
- 3 Remove the front seat leg bolts using 13MM socket wrench.
- 4 Place one spacer over each bolt hole. Place washer and bolt through RAM® No-Drill™ base and hand thread into place. Use 17MM socket to tighten the bolts. Torque to manufactured specs.

Note that once installed, this base will slightly lessen the amount of forward travel available to the passenger side seat. Accessing the glove box is still possible once system is installed.

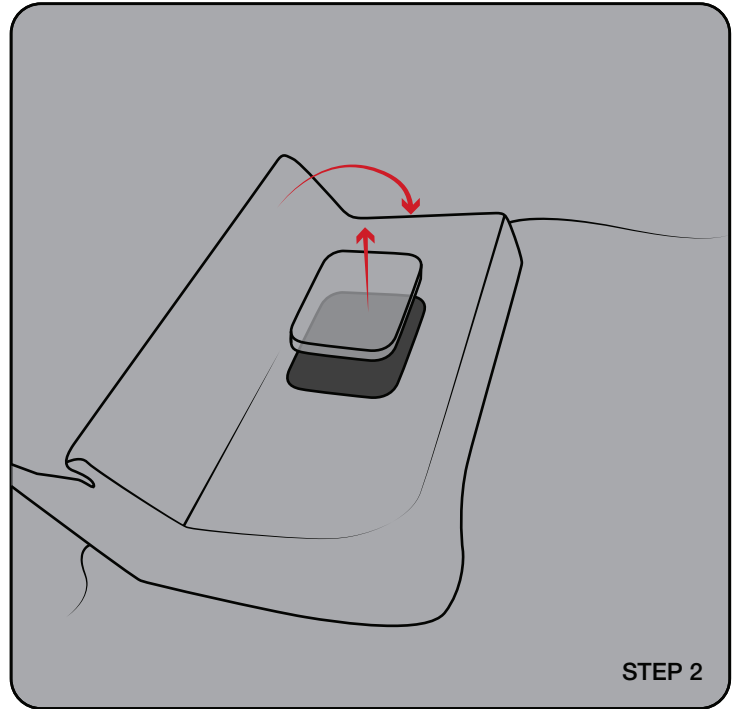

Optional Foot Stabilizer

The use of the stabilizer foot is recommended to reduce bounce in all applications. Simply replace one of the carriage bolts holding the pole system or riser in place with the stabilizer foot as shown. You will need a 1/2" box wrench to tighten the hardware. The part number for the stabilizer foot kit is RAM-FOOT2. Slide the bolt through the foot, slide a lock washer over the thread so it rest on the foot. Place a nut over the thread and tighten to secure the foot over the head of the bolt. Next, thread a nut over the bolt and slide another lock washer over the bolt. Pass the foot up through the base from the bottom. Once through the base, slide the flat washer, lock washer, then thread the nut over the bolt. Position foot while hardware is loose so it is supporting the base off the floor. Once in position, tighten the nut so that it forces the foot down against the floor. Secure with remaining nut and washers on top.

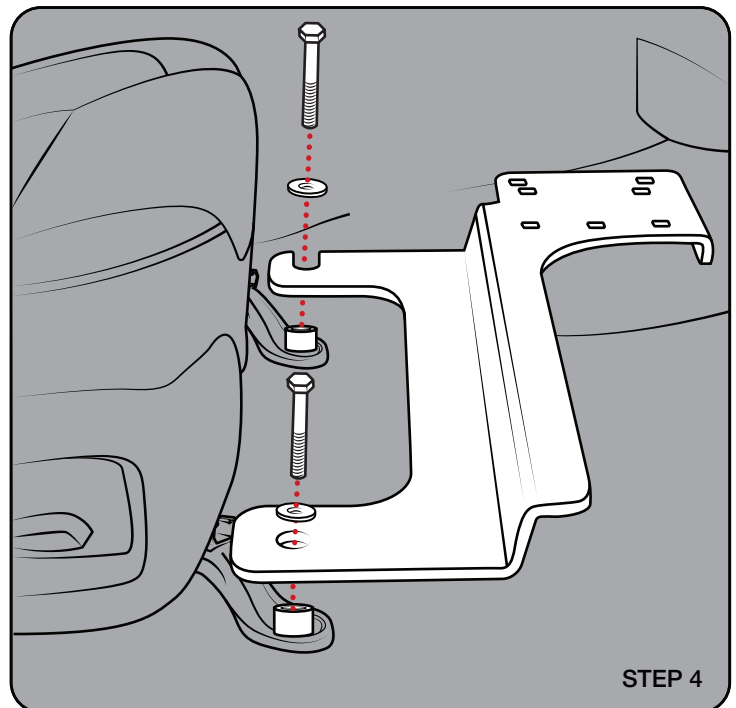
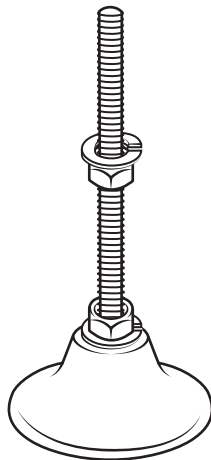

RMR-INS-VB-202-A



Safety Precaution

Do not install this product near or over an airbag deployment area or in a location that obstructs the driver's vision or interferes with vehicle operation. National Products, Inc does not assume responsibility or liability for any such personal injury, death or property damage.

Parts Index

* Not to scale

Patented & Pats. Pend.
rammount.com/ip

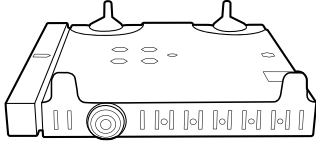

A

Tray Assembly

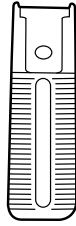

B

(x4) Long Arms



C

(x4) Short Arms



D

(x4) Angled Brackets



E

(x2) Foam Pads

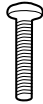

F

(x4) Screws
#8-32 x 3/4"



G

(x4) Nylock Nuts
#8-32

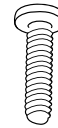

H

(x4) Screws
#10-24 x 3/4"



I

(x4) Nylock Nuts
#10-24

1 Place laptop on tray with lid open. Using a screwdriver, loosen and rotate the rear posts to seat properly against the back of your laptop.

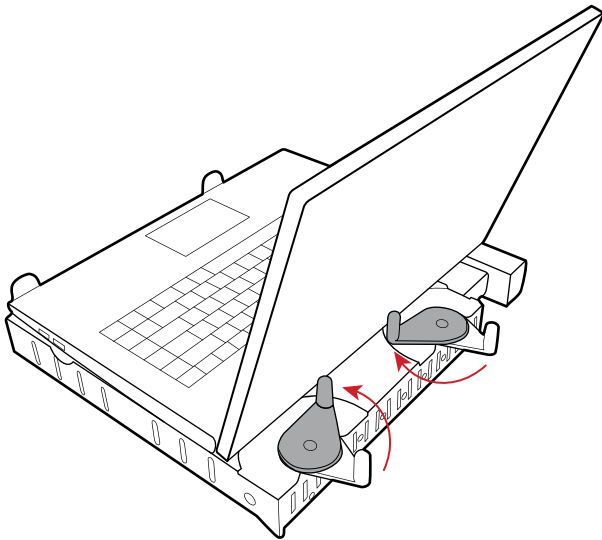

2 Select **(B)** or **(C) Arms** depending on what is most appropriate for the thickness of your laptop. Slide **(D) Angled brackets** into selected arms until you hear a satisfying "click".

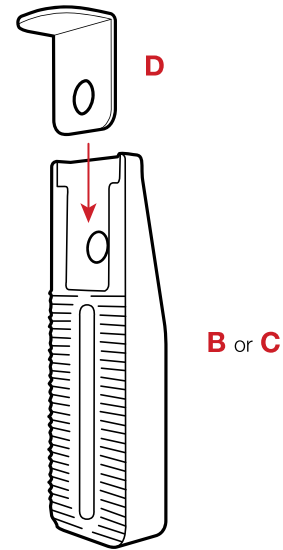

RMR-INS-2347



Safety Precaution

Do not install this product near or over an airbag deployment area or in a location that obstructs the driver's vision or interferes with vehicle operation. Electronic devices attached to this product are not to be used while vehicle is in motion. National Products, Inc. does not assume responsibility or liability for any such personal injury, death, or property damage.

- 3 Connect selected arms from Step 2 to the sides of the **(A) Tray** using **(F) Screws** and **(G) Nuts**. Select holes on the sides of the tray that will not block any necessary port or drive access.

Position the arms so that the **(D) Angled Brackets** rest flush against laptop keyboard.

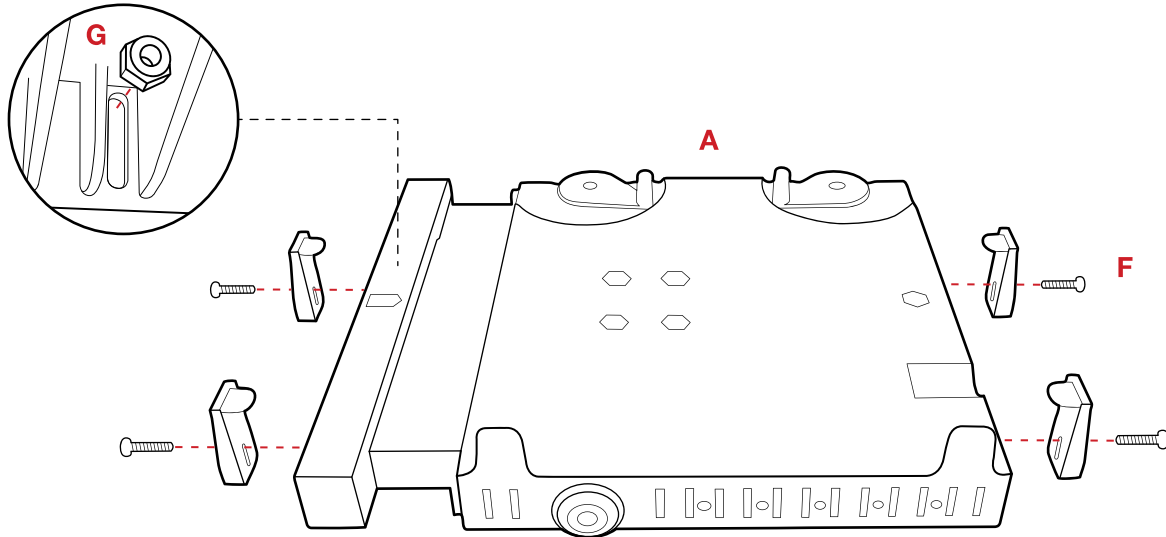

- 4 Connect **(A) Tray** to ball (not included) using **(H) Screws** and **(I) Nuts**.

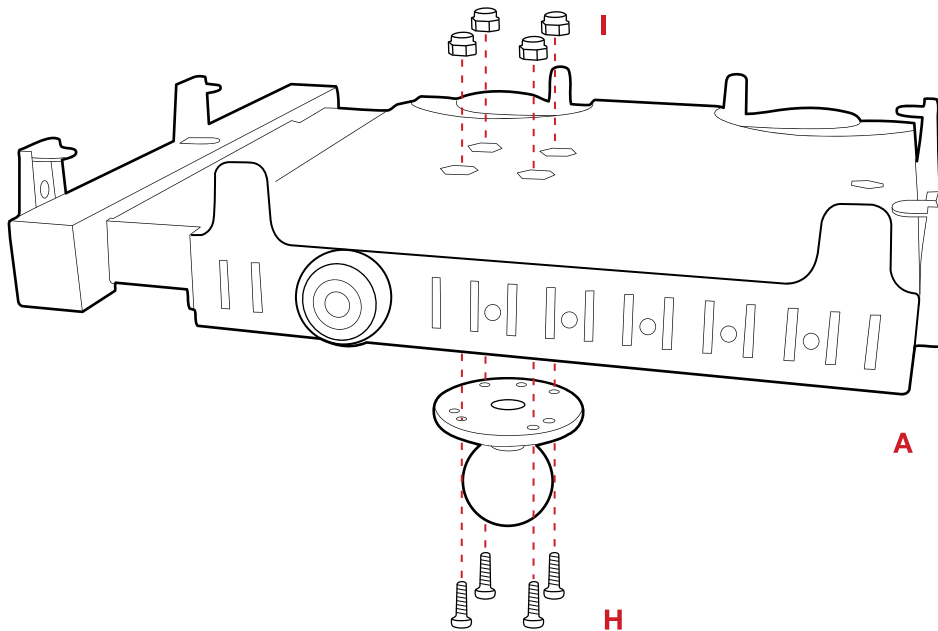

RMR-INS-2347



Safety Precaution

Do not install this product near or over an airbag deployment area or in a location that obstructs the driver's vision or interferes with vehicle operation. Electronic devices attached to this product are not to be used while vehicle is in motion. National Products, Inc. does not assume responsibility or liability for any such personal injury, death, or property damage.

Parts Index

Not to scale

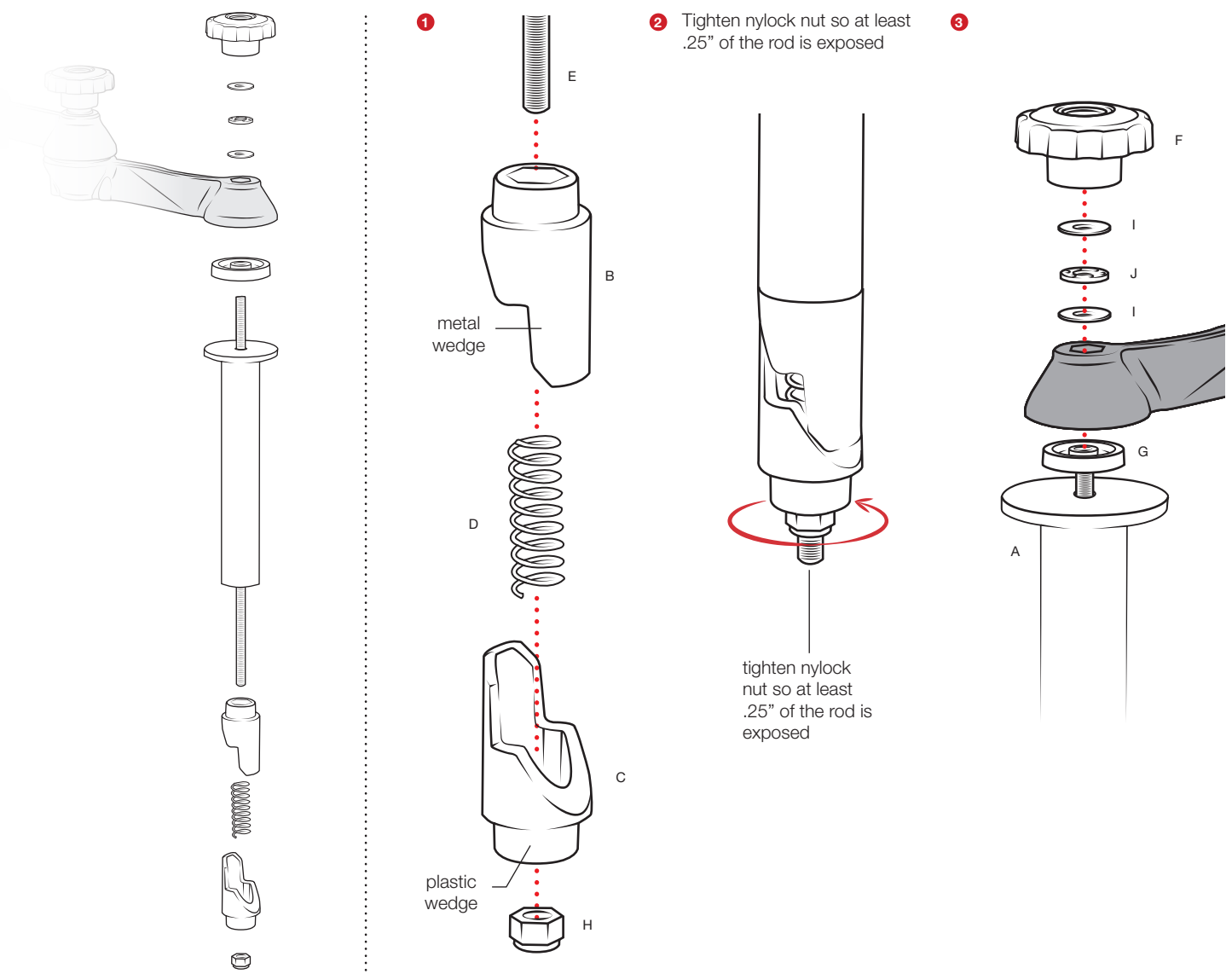
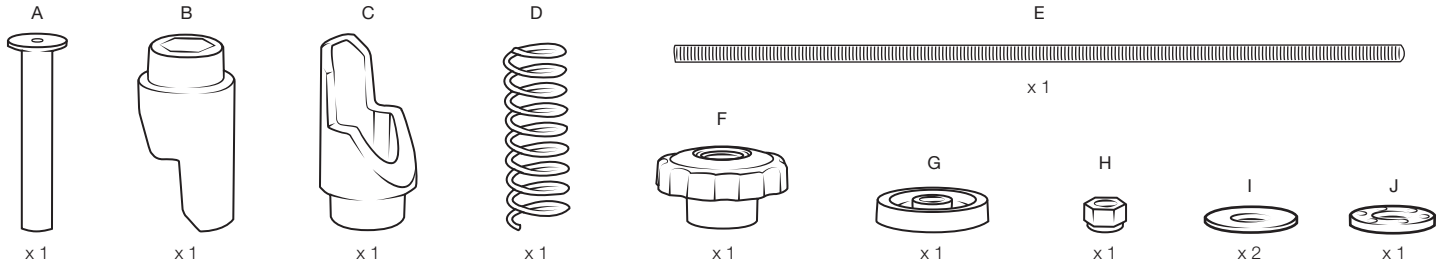

Safety Precaution

Do not install this product near or over an airbag deployment area or in a location that obstructs the driver's vision or interferes with vehicle operation. National Products, Inc does not assume responsibility or liability for any such personal injury, death or property damage.

RMR-INS-VB-TP