

CANNON®

CAUTION:
READ THIS MANUAL CAREFULLY
BEFORE OPERATING YOUR NEW
CANNON® DOWNRIGGER.
RETAIN FOR FUTURE REFERENCE.



MAG 10HS



MAG 10TS



MAG 5HS

NOTE: Do not return your CANNON® Downrigger to your retailer. Your retailer is not authorized to repair or replace this unit. You may obtain service by:

- calling CANNON® at 1-800-227-6433;
- returning your downrigger to the Factory Service Center;
- sending or taking your downrigger to any CANNON® Authorized Service Center on enclosed list.

Please include proof of purchase, serial number and purchase date for warranty service with any of the above options.

OWNER'S MANUAL

Introduction to Downriggers _____pg. 2
 Mounting Your Downrigger _____pg. 2-6
 Terminator & Line Release _____pg. 7
 Cannon Uni-Release _____pg. 7
 Attaching the Rod Holder _____pg. 8
 Wiring Your Downrigger _____pg. 9
 Operating Your Downrigger _____pg. 10-11
 The Short Stop System _____pg. 11

Maintaining Your Downrigger _____pg. 11
 Positive Ion Control _____pg. 12
 The Effects of Blowback _____pg. 12-13
 Troubleshooting _____pg. 13
 Trolling Tips _____pg. 14
 Warranty Information _____pg. 15
 Cannon Service Policy _____pg. 15
 Authorized Service Centers _____See List

Introduction to Controlled Depth Fishing

Undoubtedly there are many fishermen familiar with the methods and use of controlled depth fishing. During the mid 1960's the state of Michigan introduced Pacific salmon into the Great lakes in an attempt to revitalize its sport fishing industry. From this successful transplant, new fishing techniques and equipment were developed. One such method was controlled depth fishing which enabled fishermen to place a lure at a desired depth by utilizing downriggers.

Because of the varying factors (water temperature, thermocline, weather, tides, time of day, or time of year) it is necessary for successful fishing to maintain specific water depths that coincide with fish movements and feeding patterns.

One essential feature of the downrigger is the depth meter or gauge that indicates lure depth. This allows the angler to control as well as return to specific depths where fish have been caught.

Due to the success of controlled depth fishing, downriggers are now being used throughout the world to catch a wide variety of species in both fresh and salt water. Whether fishing for blues off Rhode Island, walleyes in Lake Erie, sailfish off the coast of Florida, or stripers in Tennessee, the use of downriggers will make your fishing more successful and more enjoyable.

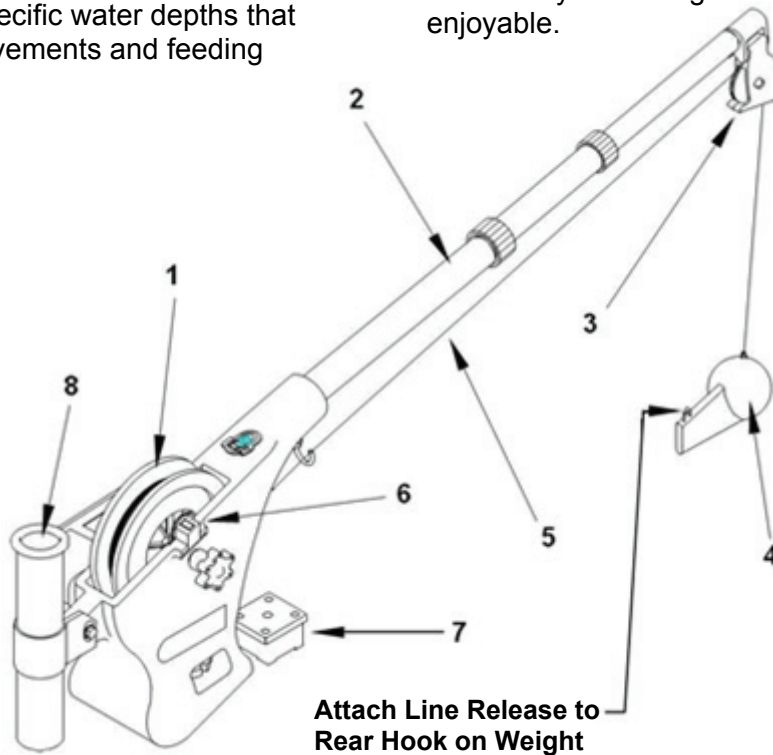

Attach Line Release to Rear Hook on Weight

Parts Description

1. **Reel** This is used to spool the cable, available in lengths ranging from 150 to 400 feet.
2. **Boom** This is used to extend the weight out from the body of the downrigger and has a pulley fixed to its end. Boom lengths range from 24 to 53 inches.
3. **Swivel Head** This relays the cable at the end of the boom to lower the weight.
4. **Weight** This is used to maintain the depth at which you want to fish. Sizes of weights range from 4 to 20 lbs.
5. **Cable** This connects to the weight. Cable material is 150 lb. test stainless steel cable.
6. **Depth Meter** This determines how much cable you have run out, enabling you to choose your trolling depth.
7. **Mounting Base** This attaches to the boat, enabling you to place the downrigger where you choose.
8. **Rod Holder** This holds your fishing rods while trolling and may also be used for storing rods.

Downrigger Mounting on Boats

A downrigger should be mounted where ever it is easy to operate and observe. You want to be able to see your fishing rod and to react quickly. So, choosing a good spot to mount your downrigger on your boat is 99% of the job.

Due to the great variety of boats available, mounting your downrigger can be a dilemma. Having proper mounting accessories is essential. Cannon has a complete line of mounting accessories to conveniently mount your downriggers on any boat.

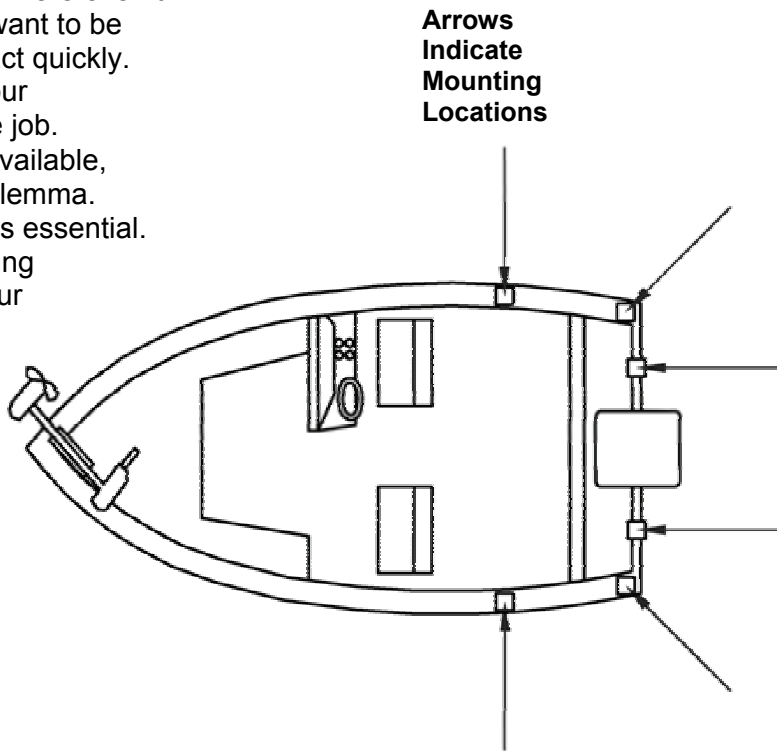

Mounting Accessories

Deck Plates are necessary when extra strength must be added to the base material of the boat and for attaching the downrigger to other mounting accessories.

Gimbal Mounts are designed to fit medium-sized flush mounted rod holders built into the gunwale of many larger fishing boats and cruisers. Only sturdy, high quality rod holders should be used for this temporary mounting system. Gimbal mounts are available in 9" or 12" post lengths.

Clamp Mounts can be mounted at the junction of two rail sections with the aid of two 1/4" pieces of plywood. They will protect your rail from any marks from the clamp and provide a non-slip urface.

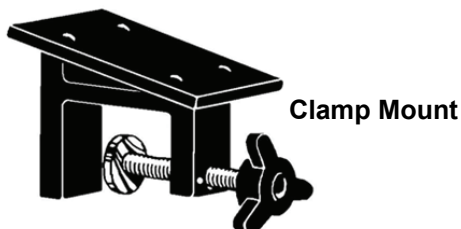
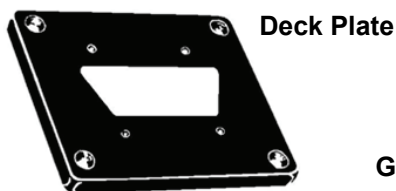

Side Rail Mounting

Side/Rail mounts can be mounted to a welded T-section. It can also be used at the two rail section butt joint. In both installations it is recommended to use a non-slip material, such as rubber or a thin wood sheet, between metal surfaces.

You can also use these for mounting to a very narrow side gunwale. There is a plate provided for back-up with bolts and washers. If the gunwale compartment is foamed in, then wellnuts should be used. It is also recommended to install two additional flat head screws through the top plate for stabilization (you will need to drill and countersink).

Side/Rail on T-Section

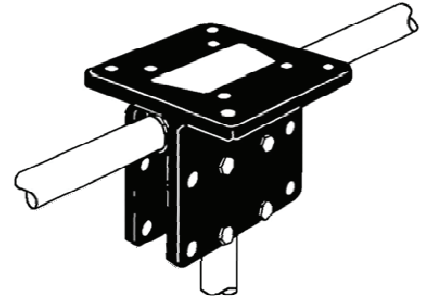

Side/Rail on Gunwale

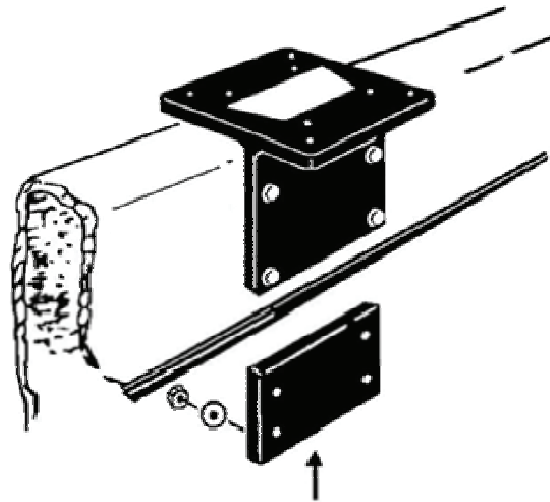

NOTE: In no case should this mount be used on fiberglass 1/4" thick or less unless it is foamed in.

Pedestal Mounting

Pedestals are used wherever additional height is needed for ease of operation or to clear obstructions, such as handrails.

Caution: When using a pedestal mount or side/rail mount, do not extend the telescopic boom on your Mag 10 HS \ Mag 10 TS. The increased leverage will cause excessive strain and possible failure of the mount.

Pedestal for Additional Height

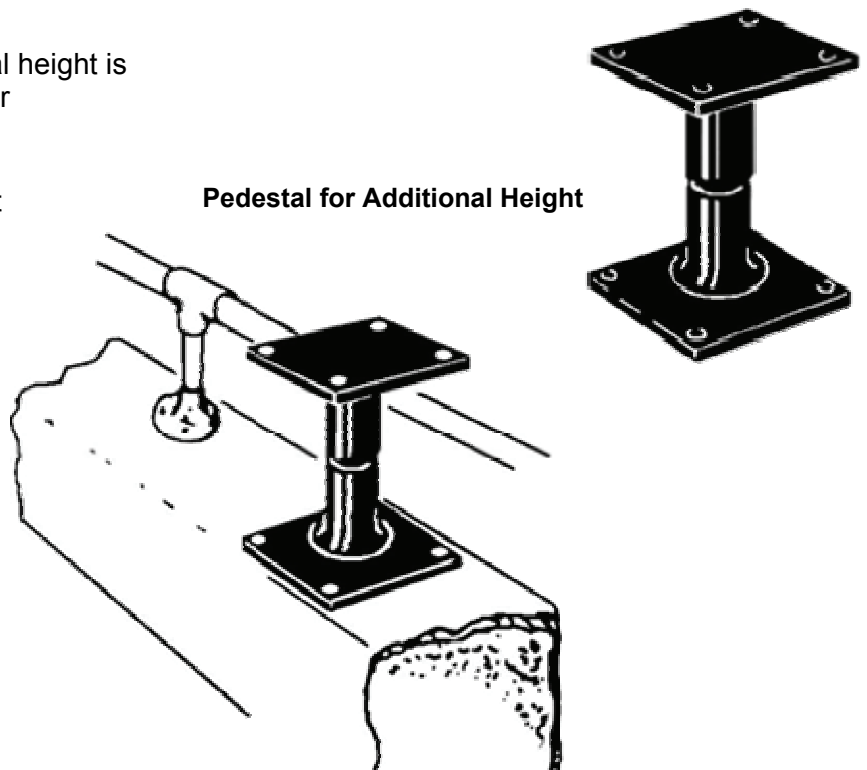

Installing the Base on Your Boat

Decks up to 7/16" thick

Where access to the underside of the deck is not available, the mounting base can be mounted using wellnuts. Use the base as a template to mark locations and drill four 1/2" holes. Mount the base using four 1/4-20 x 4" truss head screws and four wellnuts. Tighten the screws so the wellnuts are firmly compressed as pictured.

Decks thicker than 7/16"

For decks thicker than 7/16", or where the underside of the deck is accessible, mount the base with screws, nuts, and washers. Use the base as a template to mark the locations and drill four 9/32" holes. Use four 1/4-20 x 4" truss head screws and four each flat washers, lock washers, and nuts. Fasten the base to the deck as pictured. **NOTE:** Wellnuts cannot be used on decks thicker than 7/16".

Decks thinner than 1/4"

Use a Cannon deck plate to prevent deflection and add stability to decks thinner than 1/4". Use the deck plate as a template to mark the hole locations.

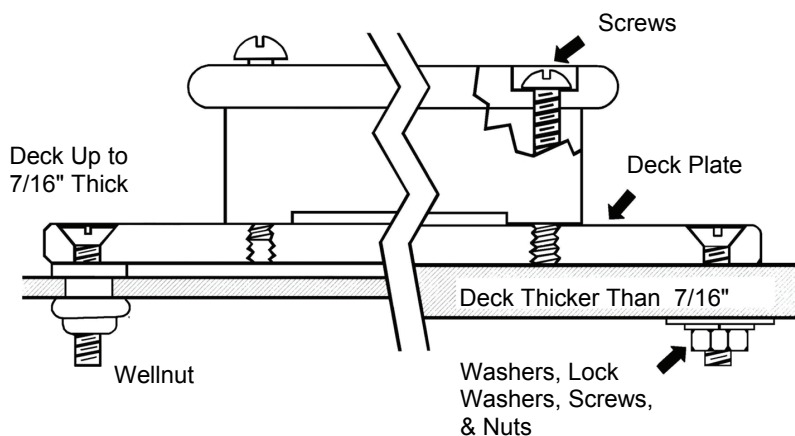

Decks up to
7/16" Thick

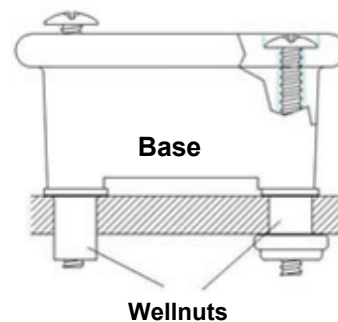

Decks Thicker
Than 7/16" Thick

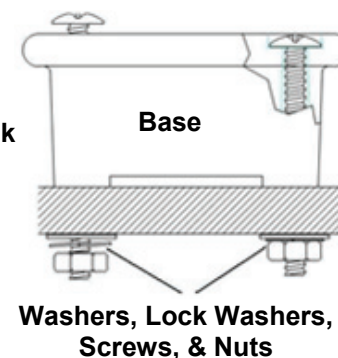

Washers, Lock Washers,
Screws, & Nuts

If access to the underside of the deck is not available, the deck plate can be mounted using screws and wellnuts. Drill 1/2" holes. Use four 1/4-20 x 2" flat head screws and four wellnuts to mount deck plate as pictured. Tighten the screws so the wellnuts are firmly compressed.

Where the underside is accessible, the deck plate can be mounted using screws, nuts, and washers. Drill 9/32" holes. Use four 1/4-20 x 2" flat head screws, nuts and washers (flat and lock). Fasten plate to deck as pictured. To secure the mounting base to the deckplate use four 1/4-20 x 2" truss head screws.

NOTE: When using the telescopic boom, we strongly recommend the use of a deck plate on all boats to provide adequate stability for the downrigger.

FOR MAG 10 HS and MAG 10 TS:

The Low-Profile Swivel Base mounting follows the same procedure as for the deck plate except that four 1/4"-20 x 2 1/2" truss head screws are used to fasten the mounting base and four additional 1/4"-20 x 2 1/2" truss head screws fix the swivel base to the boat deck.

Low-Profile Swivel Base

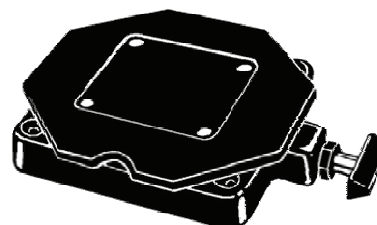

Mounting the Downrigger on the Base

Slide body over the lip of the base, with boom outboard or facing the stern. Lift Lock Knob to hold threaded shaft clear of base until body completely covers base. Turn Lock Knob clockwise to tighten the downrigger to the base.

Tip: Periodically check base to ensure integrity. The base should be replaced at least every 5 years.

Setting Up Your Downrigger

Attaching the Boom

Telescopic Boom

The intermediate section of the telescopic boom must be extended approximately 5" before the boom locking screw can engage the hole in the boom. Slip the boom end into the frame and align the holes. Secure with boom locking screw.

To adjust boom length, with the boom extending away from you, rotate clamps approximately 1/4 turn counter-clockwise to unlock, and slide boom section to desired position. To lock, rotate clamp clockwise until tight.

The Standard 24 Inch Boom inserts into the downrigger frame. Be sure that the boom is held securely by seating it firmly against the shoulder inside the frame and fastening the boom locking screw such that it engages the hole in the boom.

Assemble Swivel Head To Boom

Insert the telescopic boom-end into the boom-align holes and fasten in place with a #8x5/8 screw. Spread the swivel head side plates and slip the assembly over the boom end axle. Snap the assembly together and install two #4x1/2" screws into the swivel head.

TIP: Adjusting the angle of the boom head can help control cable wrap on the reel.

TIP: Whenever downriggers with boom lengths beyond 24" are used, Cannon's Retro-Ease Weight Retriever will make bringing in the weight safe and easy. It attaches to the cable below the boom end allowing you to pull the weight to yourself without having to lean way out or collapse the boom to reach the weight.

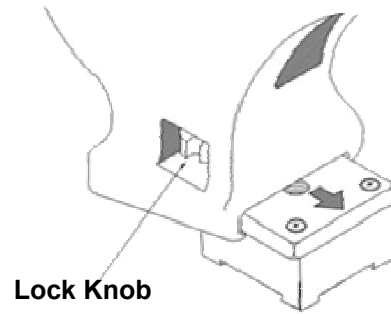

Lock Knob

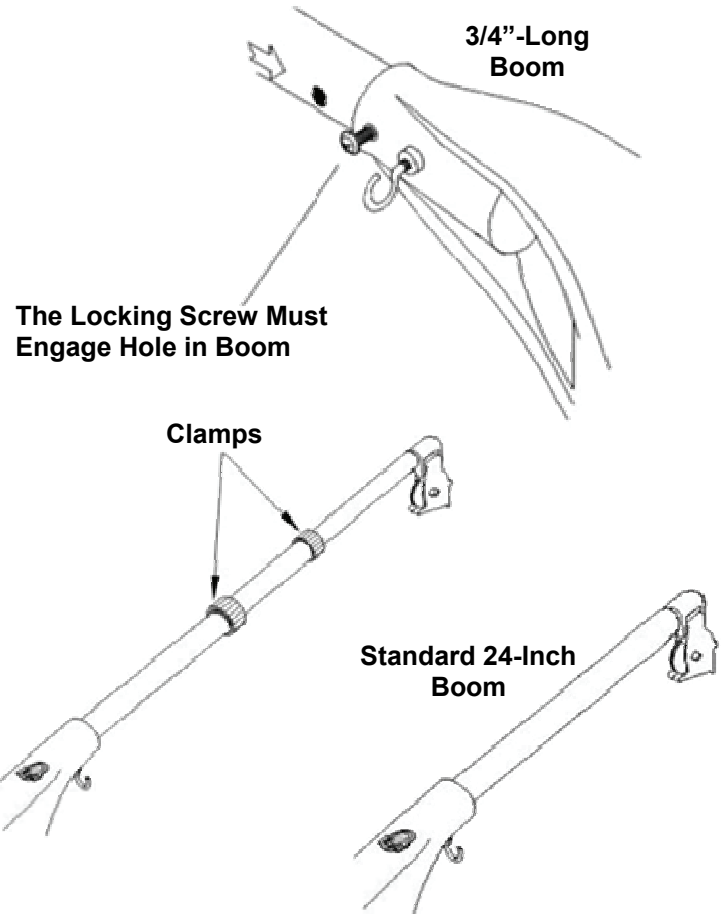

The Locking Screw Must Engage Hole in Boom

Clamps

Standard 24-Inch Boom

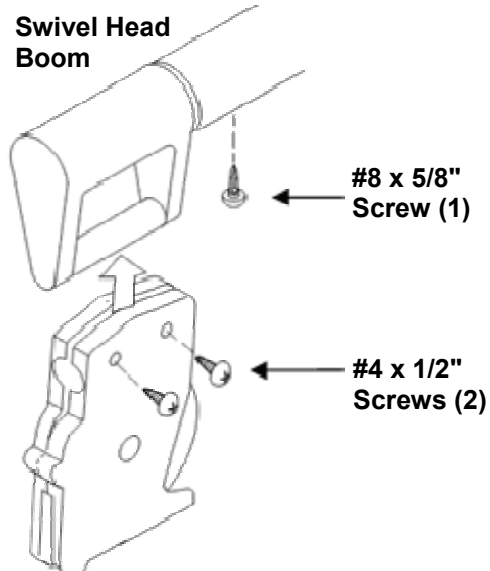

#8 x 5/8" Screw (1)

#4 x 1/2" Screws (2)

Terminating the Downrigger Cable

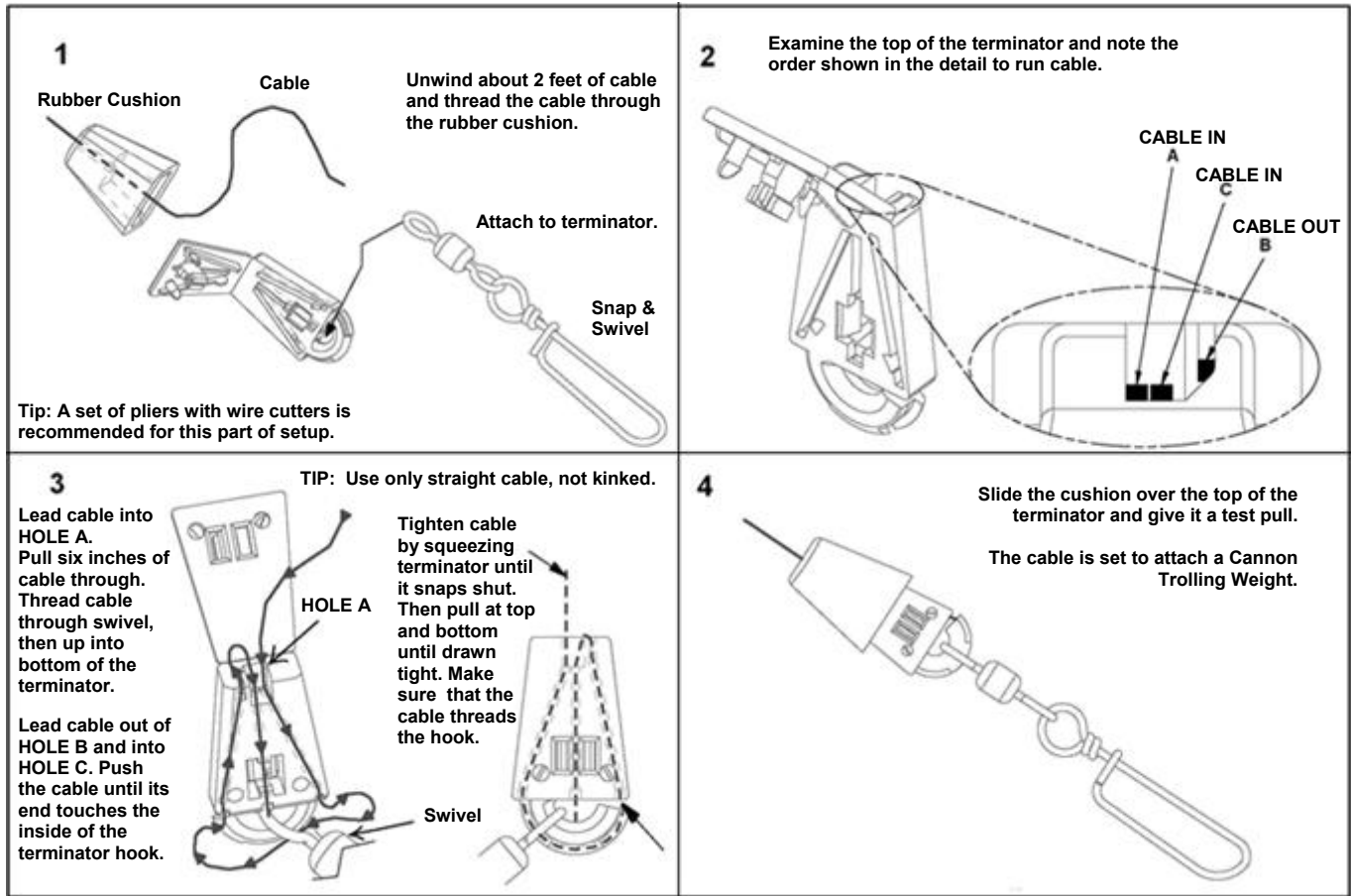

Cannon Uni-Release

The Cannon Uni-Release attaches directly to the downrigger weight. Attach fishing line to the clip at the end of the release, and then click through a series of increasing tension settings. The release can be used with any test line on salt or fresh water and may be adjusted from 2 to 22 pounds of grip tension on the line.

To change line release tension, turn tension knob to (+) to increase or (-) to decrease. Tension also may vary according to where the line is placed in the grips. Higher tension is on the line if it is set back toward the hinge, and lower if set closer to the opening. To open the release, spread the release arms with thumb and forefinger applying pressure to the sides.

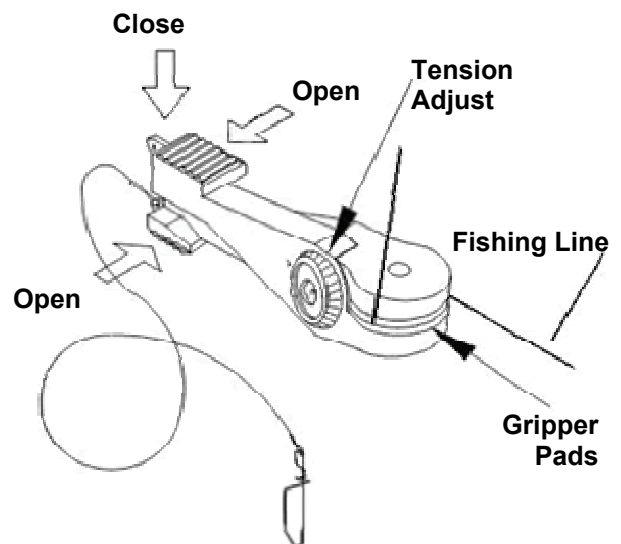

Attaching the Rod Holder

The positive lock rod holder incorporates a locking disk that allows the rod holder to be aligned in 15 degree increments. Slide the rod holder tube into the clamp to the desired position within the recommended area (see below).

Be sure the angled shoulders are facing up. Place the locking disk into the mating recess of the frame.

Slip the clamp arms in place where the obround tab on the disk fits into the slot on the clamp. Slide the star washer between the arm of the clamp and the frame. Place the flat washer onto the bolt. Then insert the bolt with washer through the clamp by entering the disk, going through the frame, the star washer, and out the other side of the clamp. Tighten the nut to secure the rod holder. Reposition the rod holder by loosening the nut and adjusting the tilt.

CAUTION: This rod holder is intended for use of up to 30 lb. test line only, and is not recommended for use with any tackle IGFA rated higher than 30 lb. A safety strap (not included) is recommended for all applications.

The rod holder assembly is not warranted when used with tackle above 30 lbs. Equipment placed in the rod holders and the loss thereof is the responsibility of the user and is in no way warranted by JOHNSON OUTDOORS, INC. Mounting must be in accordance with the above instructions and diagram to be warranted.

Single Rod Holder Assembly

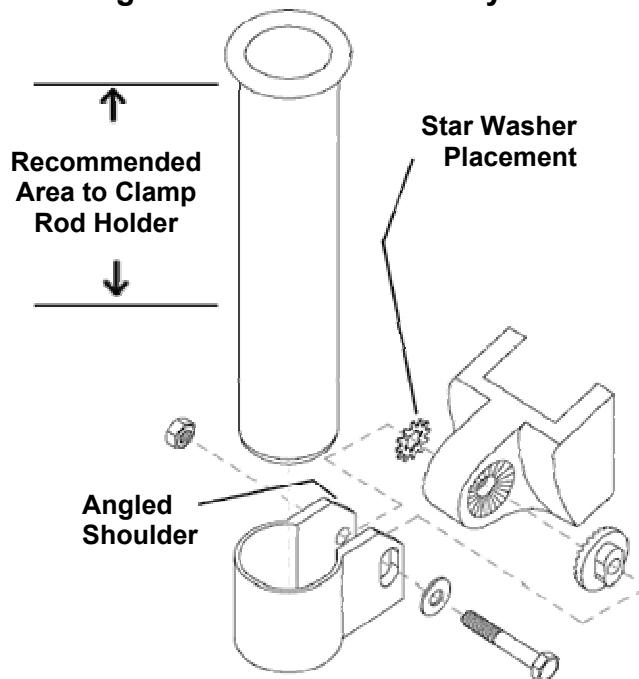

Dual Rod Holder Assembly

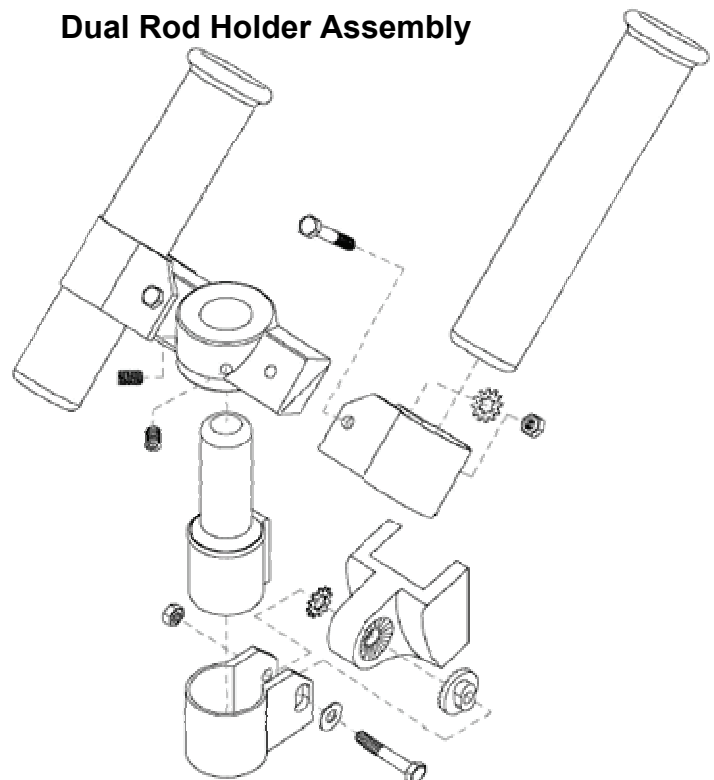

Wiring Your Downrigger Your Boat's Electrical Condition

It is important to make sure that your boat is properly set up before installing your Mag 10HS \ Mag 10TS \ Mag 5HS with Positive Ion Control. Whenever a boat is in water, various submerged parts interact to create weak electrical currents. These weak electrical currents must be controlled to extend the life of the boat's metal parts and ensure a good fish catching environment.

Check the zinc sacrificial anodes on your boat and on the outboard/outdrive. If they are more than 50% dissolved they should be replaced. Any coating of slime or growth should be cleaned off. All metal parts including the hull (if metal) must be interconnected by a grounding wire. This includes motor shafts, outdrives, and through hull fittings.

If your boat and zincs are set up correctly, the voltage on the stainless steel spool wire of your downrigger should be positive when in contact with the water. The following tips can be useful:

- Use Cannon vinyl coated lead weights. Lead, if not pure, can produce negative charges.
- Use the trolling weight insulators supplied with your downrigger. This insulates your weight from the positive charge on the cable. This will also ensure that the trolling weight will stop at water level when retrieved.
- The cable on your downrigger should be replaced every two years. Etching of the cable can weaken it physically and electrically.
- In saltwater, make sure the sacrificial zincs are replaced when half dissolved. This ensures that the boat will run with a neutral or slightly positive charge. Clean zincs on a regular basis with a non-corrosive brush.
- Always make sure the boat is properly grounded to the water. This will help ensure proper PIC voltage on the cable and that the Short Stop will function properly.

Electrical Specifications & Wiring Instructions

The Mag 10HS \ Mag 10TS \ Mag 5HS are rated at 25 amps (full load), 12 volts DC and is protected by a 30 amp manual reset circuit breaker. Be sure to measure the battery voltage of your boat.

WARNING! - DO NOT RUN THIS DOWNRIGGER ON A 24 VOLT BATTERY SYSTEM. THIS WILL DAMAGE THE UNIT AND VOID YOUR WARRANTY.

Connecting to the Battery:

It is strongly recommended that a fuse or manual-reset circuit breaker be installed at the battery on the positive lead of the power cable or that you connect the downrigger to a battery selector switch. (See Fuse and Wire Specifications below.)

Connect the positive lead (RED) to the (+) post on your battery or the downrigger will not operate. Use the new quick disconnect plug to remove the downrigger without touching the battery.

Tip: Control degradation of the power cables and limit corrosion by using Cannon Ox-Not anti-oxidant gel on all connections.

FUSE / BREAKER SPECIFICATIONS:

30 Amp, 32 Volt, waterproof, fast blow.

WIRE SPECIFICATIONS:

0-15 ft.	(0-5 meters)	10 gauge
15-25 ft.	(5-8 meters)	8 gauge
25-30 ft.	(8-9 meters)	6 gauge

CAUTION: When using wire longer than that provided with your unit, follow the above chart. When running more than 30 feet from the battery, contact a qualified electrician.

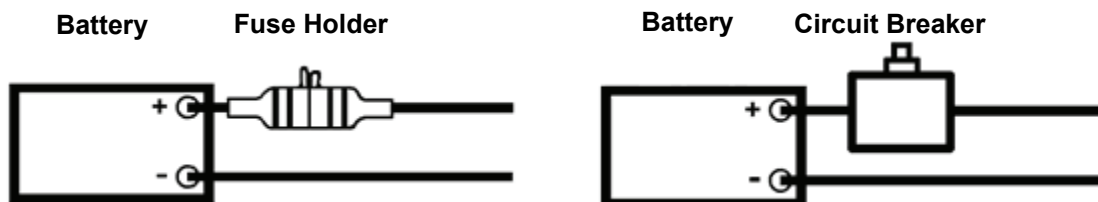

Note: Your Mag 10HS \ Mag 10TS \ Mag 5HS must be unplugged to check the natural voltage on the stainless steel cable.

Operating Your Downrigger

After mounting the Cannon downrigger to your boat, release some line from your rod and reel so that the lure is anywhere from 5 to 100 feet behind the boat. This is called drop back. Attach the fishing line firmly into the line release. Press and hold the toggle switch down to lower the weight to the desired depth as indicated on the depth meter. Place the fishing rod in the rod holder and reel up the slack so that your rod has a slight bend in it. When a fish strikes the lure, the line will separate from the release. Then you will be free to fight the fish and bring it in on your rod and reel.

Lowering the Weight

The Mag 10HS \ Mag 10TS \ Mag 5HS can lower the trolling weight manually or powered.

Manual Descent: Fast or Slow

By turning the clutch knob gently clockwise (toward the boom), you can let your trolling weight descend as fast or as slowly as you wish. Turning the knob counterclockwise (away from the boom) stops the weight. This gives you control to let it plunge rapidly or sink slowly to a predetermined trolling depth. With multiple downriggers, you could start all your weights creeping down, one at a time, and then stop them each in turn.

Powered Descent: One speed fits all.

Hold the toggle switch down until the weight reaches the desired depth and release. The motor will stop when switch is released or moved to the neutral position.

Raising the Weight

Push the toggle switch up momentarily and release. The weight will rise until it reaches the surface and then automatically stop.

If you want to raise the weight farther push the toggle switch up and hold until the weight reaches the desired position, then release.

To stop the weight during ascent, push the toggle switch down momentarily (approximately 1 second).

NOTE: If your reel continues to slip no matter how hard you tighten the brake adjust knob refer to the Troubleshooting section of this booklet.

Caution: The brake adjust knob (clutch) should be adjusted so that it is tight enough to hold the weight and the lure at the speed you are trolling. Over-tightening may cause damage to your downrigger when weight hangs up on bottom structure or other obstacles

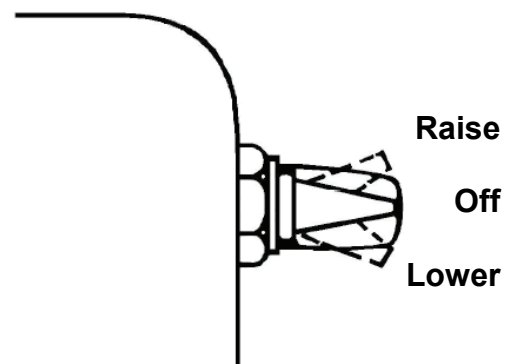
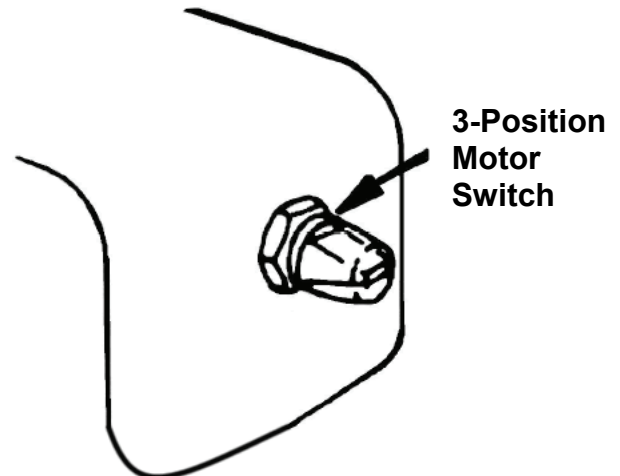
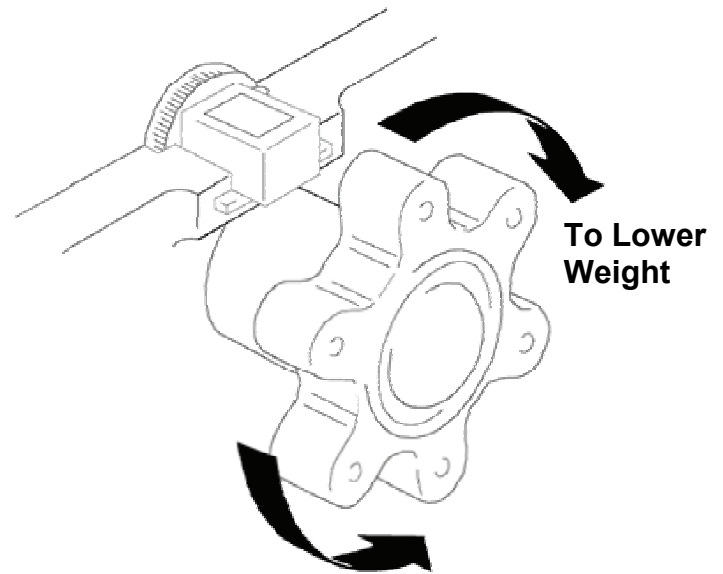

Adjusting the Depth Meter

The Cannon Depth Meter provides non-slip accuracy, plus easy resetting. To reset, just slide the meter away from the reel until the gears are disengaged. Spin meter gear to change setting.

NOTE: Actual fishing depth may vary from depth shown on meter due to trolling speed and weight of cannon ball. (See "Blowback" on page 12)

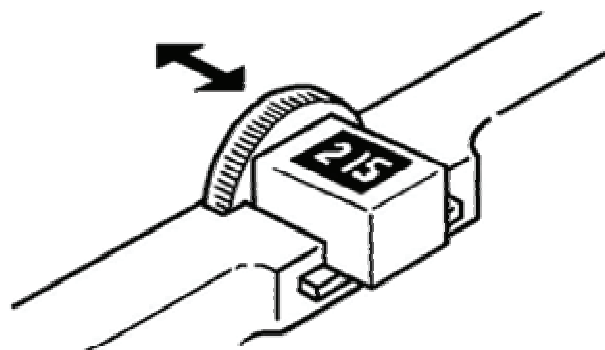

The Short Stop System

The Short Stop system is composed of three critical components: the electronic unit, the reel set screw, and the trolling weight insulator.

While the downrigger cable is in the water, there is a minute electrical current that flows between the cable and the grounded metal boat components in the water. When the cable clears the water, this current flow will stop. The Short Stop system senses this interruption and turns off the motor. The trolling weight insulator is used to break the cable contact to the water while the weight is still in the water. The reel set screw allows the circuit path to be made through the structure of the downrigger.

NOTE: It may be necessary to use two trolling weight insulators.

Stopping the weight at water level eliminates the cable strain caused by bouncing weights or weights hitting the boom end. Stopping at water level will also keep the weight from hitting the boat hull.

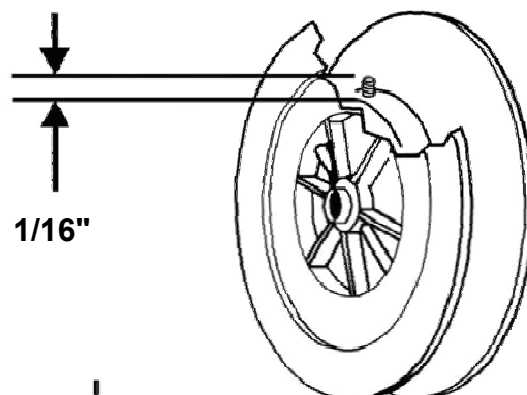

NOTICE: Short stop and Positive Ion Control features do not function when spooled with monofilament or super lines.

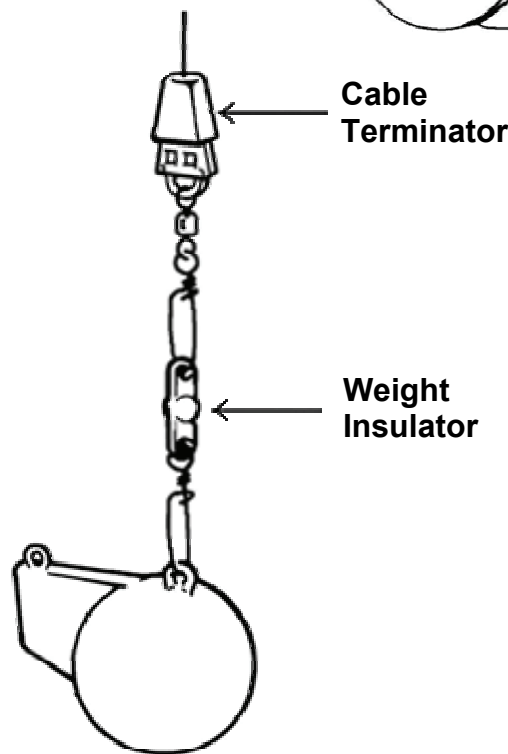

Maintaining Your Downrigger

Periodically, lightly grease the thrust bearing and bearing race found behind the clutch knob. Replace the cable at least every two years. There are no other user serviceable parts on the Mag 10HS \ Mag 10TS \ Mag 5HS. Your warranty will be void if the seal on your unit is broken. For repairs or servicing your downrigger refer to the Warranty Information section of this booklet.

The Positive Ion Control System

Your boat has an electrical charge around the hull in water. If a boat is properly bonded and properly zinced, that charge should be slightly positive when measured from ground to the downrigger cable. Positive Ion Control (PIC) is the use of electricity to control that charge and its fluctuation so that it is always maintained at a specified set voltage.

The practice of setting up and maintaining a slight positive charge on fishing gear has been used by commercial fishermen for many years. This practice has enabled some fisherman to increase yield when used along with other good fishing and boating practices.

Cannon's electric downriggers offer fishermen a big advantage in being able to stabilize and control the positive charge around their boat. Because of the Lexan® construction of the frame, Cannon downriggers are insulated from your boat's hull charge. When the stainless steel downrigger cable is lowered into the water, the natural ionization between the cable and the boat creates a positive charge of 0.7 to 0.9 volts in saltwater and 0.3 to 0.6 volts in fresh water. This natural voltage is dependent upon salinity and mineral content of the water. Your actual voltage may vary.

How the Positive Ion Control System Works

The PIC system uses an internal circuit that passes the voltage through the drive train of the Mag 10HS \ Mag 10TS \ Mag 5HS to the reel set screw. The set screw contacts the cable. Care must be taken to ensure contact between the cable and the set screw when replacing the cable. The positive Ion Control system applies a constant 0.6 volts on the trolling cable at all times.

Measuring the Natural Electrolysis and PIC Voltage on Your Boat

A voltmeter with a scale of zero to one volt will measure the natural electrolysis. Place the ground lead of the meter on the motor or the battery ground. Place the positive lead on the stainless steel downrigger cable while it is in the water. The downrigger must be unplugged. The voltage you measure on the volt meter is your boat's natural electrolysis voltage. Use the same set up to measure the PIC voltage; just plug in the Mag 10HS \ Mag 10TS \ Mag 5HS.

Using Positive Ion Control

Positive Ion Control is very effective when trolling. The zone of attraction created at the downrigger wire will attract the fish. It is best to use a short drop back between the downrigger release and the lure. Drop backs of 10 to 20 ft. are typical. A drop back of 50 to 100 ft will entirely negate the effects of the PIC circuit.

The PIC can be one of your best fishing advantages, depending on fish type and location. For example, Puget Sound Steelhead may not be effected the same as Great Lakes Steelhead. To fully benefit from PIC technology, it is important that your boat is properly grounded. For more information on this subject, refer to "Secrets of Fishing with Electricity" by Ollie Rode.

Blowback

Simply stated, blowback is what happens to the downrigger weight when you pull it through the water behind your boat. As your speed increases, so does the horizontal distance between the weight and your downrigger. The faster you go, the farther the weight is behind you. The farther the weight is behind you, the shallower the weight is.

The following charts provide you with blowback information for three sizes of Cannon downrigger weights pulled at three different speeds with no lures attached and with no current. Current drag, water salinity and the use of non-Cannon products will affect your actual trolling depth.

As an example, the first chart shows that if you are trolling at 4 MPH with an 8 pound weight and you have 100 FT. of cable in the water with no current; the downrigger ball is actually at a depth of about 80 FT.

Blowback Charts

8-Lb. Weight at 2, 4, and 6 MPH

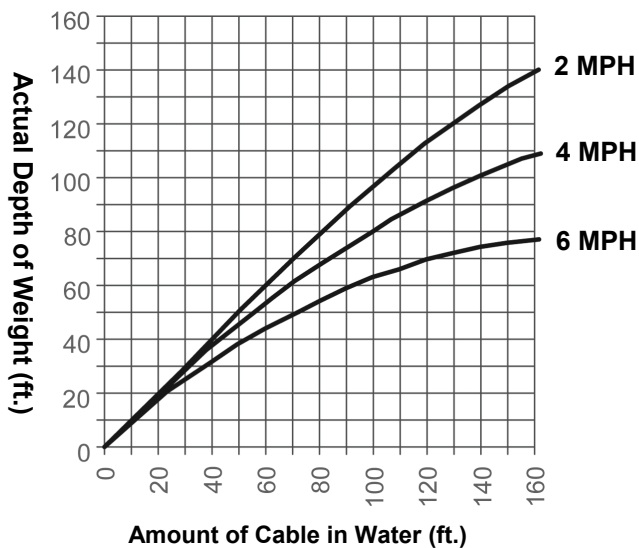

10-Lb. Weight at 2, 4, and 6 MPH

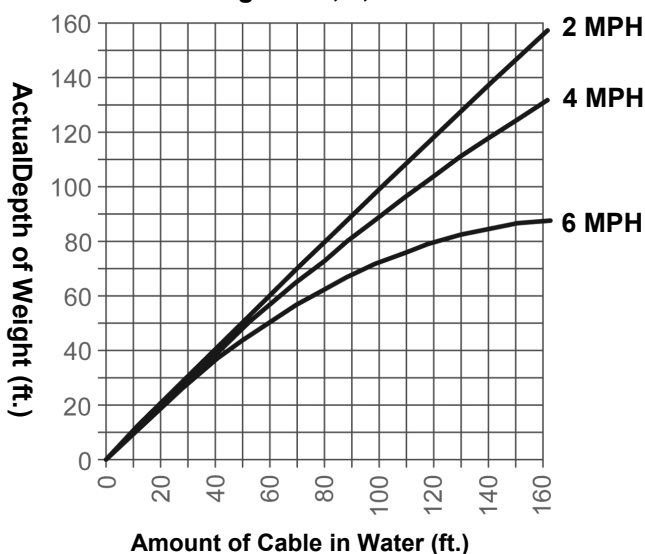

12-Lb. Weight at 2, 4, and 6 MPH

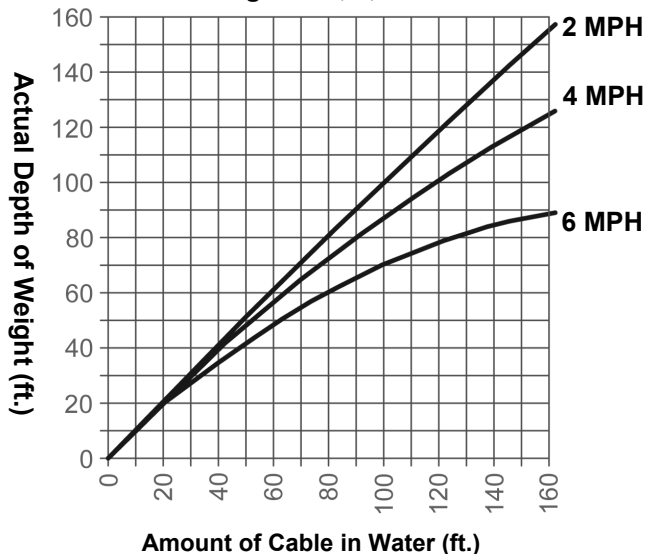

Trouble Shooting

PROBLEM: Up or down will not work.

SOLUTION:

Check the battery cable polarity then check the battery voltage.

A properly connected and charged battery is important for safety and for proper operation of the downrigger.

PROBLEM:

The Mag 10HS \ Mag 10TS \ Mag 5HS fails to continue running after toggle switch is pushed up and held momentarily, while cable is still in water, or is having problems with the PIC voltage.

SOLUTION:

Make sure your boat is properly bonded. A boat that is properly bonded has an electrical path from the negative battery terminal to all metal parts on the boat that contact water.

Additionally, in saltwater the boat must be properly zined to show a natural electrolysis voltage of 0.7 to 0.9 volts. The voltage supply to your downrigger must also be bonded to the boat.

PROBLEM:

Clutch slips

SOLUTION:

The set screw in the reel may have come loose off the shaft. Follow the instructions below:

- 1) Unwind the cable from the reel.
- 2) Remove the set screw.
- 3) Align the set screw hole in the reel with the hole in the reel shaft by inserting a 3/16" or smaller rod and rotating the reel until you feel it drop into the shaft hole.
- 4) Replace the set screw and tighten until you feel resistance.
- 5) By gently rocking the reel back and forth while tightening the set screw, you can feel it engage in the shaft hole. The half dog point on the set screw must enter the hole in the shaft; not just be tightened against the reel shaft.
- 6) The set screw should be about 1/16" above the top of the hole when it is properly seated (not so for TS models). The contact between the stainless steel cable and the set screw is important for proper operation of the Positive Ion Control system.

Ten Good Trolling Tips

1) Test your lures over the boat side before sending them down and back. Do this to make sure the lure wiggles and wobbles properly without going belly up or wandering off. Some lures can be adjusted, fine tuned actually, to impart maximum action. For example, a slight bend in the tail of a spoon or twist of the hook eye in the nose of a plug can make a noticeable difference in how the lure performs.

Also, when running two or more lures, make sure the offerings are compatible. Lures that run out of harmony with each other are bound to tangle and that means wasted time to straighten out the mess. Testing them first will avoid the problem.

2) Consider different sizes, shapes, and colors of lures. No one has ever figured out with precision what makes a fish strike or snub a lure. There is no doubt, that matching the forage (minnows, crayfish, etc.) in color, shape, action, and size can help trigger those strikes from hungry fish. On the other hand, if fish such as bluegills, small mouth bass or Coho salmon are protecting spawning beds, they may attack whatever is threatening. So, bright colors in lures may out produce bland colors.

3) Vary trolling speeds. Goosing the engine now and then or slowing to a crawl every so often will change the action of the lures and may get fish to strike them.

4) Vary trolling patterns and lead lengths. The amount of line you let out often determines how deep the lure will run and, to some extent, what degree of action it will impart. For starters, consider running lures about ten feet behind downrigger weights. If flat line trolling, put them back about fifty feet, then experiment depending on what the fish do.

Trolling patterns affect lure action too, that is why some anglers like to wheel a lazy S course. On turns, outside lures will speed up momentarily while inside lures hang for a moment or two. Fish may nail lures that change speeds. Also, zigzag patterns allow for more water coverage, plus it keeps lures out of propeller boil, an important consideration for browns and other wary species.

5) Locate fish on a vertical plane. Place lures in areas where fish might be. Skilled fishermen call these areas the "strike zones". They include the edges of the weed beds, structure along bottom, drop-offs, preferred temperature of the target species, and the thermocline. Remember that fish occupy certain areas for certain reasons (sources of food, protective cover, preferred temperatures, etc.).

6) Consider special knots and swivels. A good ball bearing swivel will all but eliminate line twist and will aid in getting maximum performance from a lure. Many anglers add the tiny swivels to split rings already on the lure itself. On the other hand, a swivel may dampen the action of a sensitive lure, such as a Rapala. Some fisherman tie tiny improved cinch or loop knots. Loop knots in particular may enhance up and down and side to side action of lures. Any good fishing manual will explain how to tie these and other knots.

7) Consider releases for flatline trolling. A good tip is to secure a piece of downrigger cable or heavy monofilament to the water ski hook or handle below the transom of most boats. To the other end of the mono or cable, add a pinch-release. After letting out your lure to the desire distance, put the rod in its holder, then bend the tip and secure the fishing line in the release.

8) Add a weed guard. Having trouble with weeds hanging up lures? Consider tying a three-inch piece of monofilament a foot above the lure. Leaves, smaller weeds and other debris may catch here momentarily then fall off to the side of the lure without tangling. Weedless lures are another smart consideration. Downrigger cables are effective weed catchers when trolling for pike, muskies, or bass in weed-infested lakes.

9) Add a stinger hook. When fish short strike, slap at lures without becoming hooked, adding a stinger hook can solve the problem. Simply tie a treble hook to one end of a four inch piece of monofilament and then tie the extra hook to the last gang of hooks on your lure. The stinger hook, which trails the lure, provides extra insurance.

10) Keep hooks sharp. Some of the best fishermen sharpen all hooks after every fish caught. Hooks get dull through both use and misuse, and probably more fish are lost to dull points than anything else.

CANNON® LIMITED WARRANTY

Johnson Outdoors Inc. warrants to the original purchaser that if the accompanying product (see exclusions below) proves to be defective in material or workmanship within the following warranty periods, Johnson Outdoors Inc. will, at its option, either repair or replace same without charge (but no cash refunds will be made):

1) The boom, motor, and reels, plus all Lexan®* parts, including but not limited to frames and bases, will be free from defects in materials and workmanship, subject to normal wear and tear, for the original purchaser's lifetime.

2) All other items will have 1-year limited warranties from the date of original retail purchase, except THE FOLLOWING ITEMS THAT HAVE NO WARRANTY WHATSOEVER: boot covers, clothing, Dacron line, rubber bands, swivel lock pin, weights, and wire cable.

This limited warranty may be enforced only by the original purchaser; all subsequent purchasers acquire the product "as is" without any benefit of this limited warranty. Repair or replacement of the product as set forth in this limited warranty shall be the original purchaser's sole and exclusive remedy and Johnson Outdoors Inc.'s sole and exclusive liability for breach of this warranty.

EXCLUSIONS

This warranty does not apply in the following circumstances:

- When the product has been connected, installed, combined, altered, adjusted, serviced, repaired, or handled in a manner other than according to the instructions furnished with the product
- When the motor housing is opened by anyone other than Cannon® Authorized service repair personnel.
- When any defect, problem, loss, or damage has resulted from any accident, misuse, negligence, carelessness, or abnormal use, or from any failure to provide reasonable and necessary maintenance in accordance with the instructions of the owner's manual

LIMITATION AND EXCLUSION OF IMPLIED WARRANTIES AND CERTAIN DAMAGES

THERE ARE NO EXPRESS WARRANTIES OTHER THAN THESE LIMITED WARRANTIES. JOHNSON OUTDOORS INC. DISCLAIMS LIABILITY FOR INCIDENTAL AND CONSEQUENTIAL DAMAGES, AND IN NO EVENT SHALL ANY IMPLIED WARRANTIES (EXCEPT ON THE BOOM, MOTOR, REELS, AND ALL LEXAN®* PARTS), INCLUDING ANY IMPLIED WARRANTY OF MERCHANTABILITY OR FITNESS FOR PARTICULAR PURPOSE, EXTEND BEYOND ONE YEAR FROM THE DATE OF PURCHASE (AND IN THE CASE OF THE BOOT COVERS, CLOTHING, DACRON LINE, RUBBER BANDS, SWIVEL LOCK PIN, WEIGHTS, AND WIRE CABLE, JOHNSON OUTDOORS INC. DISCLAIMS ALL IMPLIED WARRANTIES). THIS WRITING CONSTITUTES THE ENTIRE AGREEMENT OF THE PARTIES WITH RESPECT TO THE SUBJECT MATTER HEREOF; NO WAIVER OR AMENDMENT SHALL BE VALID UNLESS IN WRITING SIGNED BY JOHNSON OUTDOORS INC.

Some states do not allow limitations on how long an implied warranty lasts or the exclusion or limitation of consequential damages, so the above limitation or exclusion may not apply to you. This warranty gives you specific legal rights, and you may also have other rights that vary from state to state.

* Lexan is a registered trademark of General Electric.

CANNON® SERVICE POLICY

AFTER THE APPLICABLE WARRANTY PERIOD

After the applicable warranty period, or, if one of the above exclusions applies, Cannon® products will be repaired for a charge of parts plus labor. All factory repairs, after the applicable warranty period, carry a 90-Day Limited Warranty, subject to the exclusions and limitations stated above.

TO ENFORCE WARRANTY OR TO OBTAIN REPAIRS AFTER WARRANTY

To obtain warranty service in the U.S., the downrigger or part believed to be defective and the proof of original purchase (including the date of purchase) must be presented to a Cannon® Authorized Service Center or to Cannon®'s factory service center in Mankato, MN. Except as noted below, any charges incurred for service calls, transportation or shipping/freight to/from the Cannon® Authorized Service Center or Cannon®'s factory, labor to haul out, remove, re-install or re-rig products for warranty service, or any similar items are the sole and exclusive responsibility of the purchaser. Downriggers purchased outside of the U.S. (or parts of such downriggers) must be returned prepaid with proof of purchase (including the date of purchase and serial number) to any Authorized Cannon® Service Center in the country of purchase. Warranty service can be arranged by contacting a Cannon® Authorized Service Center listed on the enclosed sheet, or by contacting the factory at 1-800-227-6433 or Fax 1-800-527-4464. If the necessary repairs are covered by the warranty, we will pay the return shipping charges to any destination within the United States.

DO NOT return your Cannon® downrigger or parts to your retailer. Your retailer is not authorized to repair or replace them.

Major parts, such as the motor and main frame, must be returned to Johnson Outdoors Inc. in Mankato, Minnesota, or a Cannon® Authorized Service Center, for repair or replacement. To reduce shipping costs, we suggest removal of loose parts such as the boom and rod holders. Small parts that can be easily removed such as the handle and/or the counter, may be removed from the downrigger and returned for repair or replacement.

Retain your sales receipt! Proof of purchase must accompany product when returned.

Return Address: Johnson Outdoors Inc.
Cannon Division
121 Power Drive
Mankato, MN 56001

FOR YOUR INFORMATION:

_____ Serial No.

_____ Date Purchased

_____ Store Where Purchased

RETAIN THIS SECTION FOR YOUR RECORDS

ENVIRONMENTAL COMPLIANCE STATEMENT:

It is the intention of Johnson Outdoors Inc. to be a responsible corporate citizen, operating in compliance with known and applicable environmental regulations, and a good neighbor in the communities where we make or sell our products.

WEEE Directive:

EU Directive 2002/96/EC "Waste of Electrical and Electronic Equipment Directive (WEEE)" impacts most distributors, sellers, and manufacturers of consumer electronics in the European Union. The WEEE Directive requires the producer of consumer electronics to take responsibility for the management of waste from their products to achieve environmentally responsible disposal during the product life cycle.

WEEE compliance may not be required in your location for electrical & electronic equipment (EEE), nor may it be required for EEE designed and intended as fixed or temporary installation in transportation vehicles such as automobiles, aircraft, and boats. In some European Union member states, these vehicles are considered outside of the scope of the Directive, and EEE for those applications can be considered excluded from the WEEE Directive requirement.

This symbol (WEEE wheelee bin) on product indicates the product must not be disposed of with other household refuse. It must be disposed of and collected for recycling and recovery of waste EEE.

Johnson Outdoors Inc. will mark all EEE products in accordance with the WEEE Directive. It is our goal to comply in the collection, treatment, recovery, and environmentally sound disposal of those products; however, these requirements do vary within European Union member states. For more information about where you should dispose of your waste equipment for recycling and recovery and/or your European Union member state requirements, please contact your dealer or distributor from which your product was purchased.



To download product manuals or purchase Cannon products from an authorized dealer, please visit our web page at www.cannondownriggers.com



Johnson Outdoors, Inc. / Cannon Division
121 Power Drive, Mankato, MN 56001
1-800-227-6433

© 2008 Johnson Outdoors, Inc. All rights reserved.

All CANNON Downriggers are covered by US Pat.D-269, 992. Copyright 2006 Johnson Outdoors, Inc. All rights reserved.
Conforms to 89/336/EEC (EMC) under standards EN 55022A, EN 50082-2 since 1996 LN V9677264

WARNING: This product contains chemical(s) known to the state of California to cause cancer and/or reproductive toxicity.