

Smart choice for power™

**xantrex™**

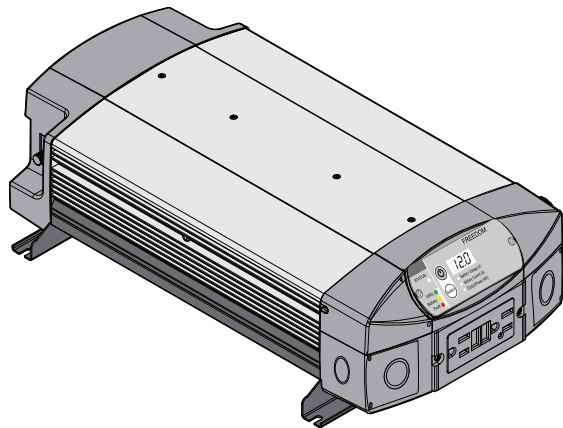

Product image shown may vary from actual product. See features for comparisons.

# Freedom Xi Inverter

## Installation Guide

### Model Product Numbers

807-1000

807-2000



Copyright © 2015 Schneider Electric. All Rights Reserved. All trademarks are owned by Schneider Electric Industries SAS or its affiliated companies.

## Exclusion for Documentation

UNLESS SPECIFICALLY AGREED TO IN WRITING, SELLER

(A) MAKES NO WARRANTY AS TO THE ACCURACY, SUFFICIENCY OR SUITABILITY OF ANY TECHNICAL OR OTHER INFORMATION PROVIDED IN ITS MANUALS OR OTHER DOCUMENTATION;

(B) ASSUMES NO RESPONSIBILITY OR LIABILITY FOR LOSSES, DAMAGES, COSTS OR EXPENSES, WHETHER SPECIAL, DIRECT, INDIRECT, CONSEQUENTIAL OR INCIDENTAL, WHICH MIGHT ARISE OUT OF THE USE OF SUCH INFORMATION. THE USE OF ANY SUCH INFORMATION WILL BE ENTIRELY AT THE USER'S RISK; AND

(C) REMINDS YOU THAT IF THIS MANUAL IS IN ANY LANGUAGE OTHER THAN ENGLISH, ALTHOUGH STEPS HAVE BEEN TAKEN TO MAINTAIN THE ACCURACY OF THE TRANSLATION, THE ACCURACY CANNOT BE GUARANTEED. APPROVED CONTENT IS CONTAINED WITH THE ENGLISH LANGUAGE VERSION WHICH IS POSTED AT WWW.XANTREX.COM.

## Document Part Number

975-0753-01-01

## Date and Revision

September 2015 Rev A

## Product Number

807-1000 (Freedom Xi 1000 120VAC)

807-2000 (Freedom Xi 2000 120VAC)

## Contact Information

Telephone: +1 800 670 0707

+1 408 987 6030

Web: [www.xantrex.com](http://www.xantrex.com)

## Information About Your System

As soon as you open your product, record the following information and be sure to keep your proof of purchase.

Serial Number \_\_\_\_\_

Product Number \_\_\_\_\_

Purchased From \_\_\_\_\_

Purchase Date \_\_\_\_\_

*To view, download, or print the latest revision, visit the website shown under Contact Information.*

# About This Guide

## Purpose

The purpose of this Installation Guide is to provide explanations and procedures for installing and configuring a Freedom Xi Sine Wave Inverter for Recreational, Fleet Vehicle, or Marine installations.

## Scope

The Guide provides safety guidelines, as well as information about operating and troubleshooting the installation. It does not provide details about particular brands of batteries. You need to consult individual battery manufacturers for this information.

## Audience

The information in this Guide is intended for qualified personnel. Qualified personnel have training, knowledge, and experience in:

- Installing electrical equipment (up to 1000 volts).
- Applying all applicable installation codes.
- Analyzing and reducing the hazards involved in performing electrical work.
- Selecting and using Personal Protective Equipment (PPE).

## Abbreviation or Acronym

A	Amps
AC	Alternating Current
DC	Direct Current
ft-lbs	Foot-pounds (a measure of torque)
kW	Kilowatts (1000 watts)
LED	Light Emitting Diode
Nm	Newton-meters (a measurement of torque)
V	Volts
VAC	Volts AC
VDC	Volts DC
W	Watts

## Related Information

You can find more information about Xantrex products and services at [www.xantrex.com](http://www.xantrex.com).

# Important Safety Instructions

---

**IMPORTANT:** READ AND SAVE THIS INSTALLATION GUIDE FOR FUTURE REFERENCE.

---

This guide contains important safety instructions for the Freedom Xi Sine Wave Inverter that must be followed during operation and troubleshooting.

**Read and keep this Installation Guide for future reference.**

Read these instructions carefully and look at the equipment to become familiar with the device before trying to install, operate, service or maintain it. The following special messages may appear throughout this bulletin or on the equipment to warn of potential hazards or to call attention to information that clarifies or simplifies a procedure.



The addition of either symbol to a “Danger” or “Warning” safety label indicates that an electrical hazard exists which will result in personal injury if the instructions are not followed.



This is the safety alert symbol. It is used to alert you to potential personal injury hazards. Obey all safety messages that follow this symbol to avoid possible injury or death.

---

## **DANGER**

**DANGER** indicates an imminently hazardous situation, which, if not avoided, will result in death or serious injury.

## **WARNING**

**WARNING** indicates a potentially hazardous situation, which, if not avoided, can result in death or serious injury.

## **CAUTION**

**CAUTION** indicates a potentially hazardous situation, which, if not avoided, can result in moderate or minor injury.

## **NOTICE**

**NOTICE** indicates a potentially hazardous situation, which, if not avoided, can result in equipment damage.

**Important:** These notes describe things which are important for you to know, however, they are not as serious as a caution or warning.

## Safety Information

1. **Before using the inverter, read all instructions and cautionary markings on the unit, the batteries, and all appropriate sections of this manual.**
2. Use of accessories not recommended or sold by the manufacturer may result in a risk of fire, electric shock, or injury to persons.
3. The inverter is designed to be connected to your AC and DC electrical systems. The manufacturer recommends that all wiring be done by a certified technician or electrician to ensure adherence to the local and national electrical codes applicable in your jurisdiction.
4. To avoid a risk of fire and electric shock, make sure that existing wiring is in good condition and that wire is not undersized. Do not operate the inverter with damaged or substandard wiring.
5. Do not operate the inverter if it has been damaged in any way.
6. This unit does not have any user-serviceable parts. Do not disassemble the inverter except where noted for connecting wiring and cabling. See your warranty for instructions on obtaining service. Attempting to service the unit yourself may result in a risk of electrical shock or fire. Internal capacitors remain charged after all power is disconnected.
7. To reduce the risk of electrical shock, disconnect both AC and DC power from the inverter before attempting any maintenance or cleaning or working on any components connected to the inverter. Turning off the inverter using the Inverter Power button on the front panel will not reduce an electrical shock hazard.
8. The inverter must be provided with an equipment-grounding conductor connected to the AC input ground.
9. Do not expose this unit to rain, snow, or liquids of any type. This product is designed for indoor use only. Damp environments will significantly shorten the life of this product and corrosion caused by dampness will not be covered by the product warranty.
10. To reduce the chance of short-circuits, always use insulated tools when installing or working with this equipment.
11. Remove personal metal items such as rings, bracelets, necklaces, and watches when working with electrical equipment.

### **DANGER**

#### **ELECTRICAL SHOCK AND FIRE HAZARD**

Installation must be done by qualified personnel to ensure compliance with all applicable installation and electrical codes and regulations. Instructions for installing the Freedom Xi Sine Wave Inverter are provided here for use by qualified personnel only.

**Failure to follow these instructions will result in death or serious injury.**

 **DANGER**

**HAZARD OF ELECTRIC SHOCK, EXPLOSION, OR ARC FLASH**

- Apply appropriate personal protective equipment (PPE) and follow safe electrical work practices. See NFPA 70E or CSA Z462.
- This equipment must only be installed and serviced by qualified electrical personnel.
- Turn off all power supplying this equipment before working on or inside equipment.
- Always use a properly rated voltage sensing device to confirm power is off.
- Replace all devices, doors, and covers before turning on power to this equipment.

**Failure to follow these instructions will result in death or serious injury.**

 **WARNING**

**FIRE AND EXPLOSION HAZARD**

- Unit's components may produce arcs or sparks.
- Do not install near batteries, in machinery space, or in an area in which ignition-protected equipment is required.

**Failure to follow these instructions can result in death or serious injury.**

Areas include any space containing gasoline-powered machinery, fuel tanks, as well as joints, fittings, or other connections between components of the fuel system.

**⚠ CAUTION**

**ELECTRICAL SHOCK AND FIRE HAZARD**

- Do not open. No serviceable parts inside. Provided with integral protection against overloads. Bonding between conduit connections is not automatic and must be provided as part of the installation.
- Read manual before installing or using.
- Do not cover or obstruct ventilation openings.
- Do not mount in zero-clearance compartment – overheating may result.
- Do not expose to rain or spray. This inverter is designed for marine applications only when additional drip protection is installed in certain orientations. See “Step 3: Mounting the Unit” on page 13 for more information.
- Use GFCIs only as specified in the manuals supplied with unit. Other types may fail to operate when connected to this unit.
- Do not connect AC OUT to any other source of power. Damage to unit may occur.
- For AC IN and AC OUT, use wires suitable for at least 75°C.

**Failure to follow these instructions can result in minor or moderate injury.**

**NOTES:**

1. Follow these instructions and those published by the battery manufacturer and the manufacturer of any equipment you intend to use in the vicinity of the battery. Review cautionary markings on these products and on the engine.
2. Freedom Xi inverter products are designed for deep cycle lead-acid batteries only. The Freedom Xi does not support lithium-ion batteries.
3. Do not use transformerless battery chargers in conjunction with the inverter due to overheating.

**⚠ CAUTION**

**PHYSICAL INJURY HAZARD**

This Freedom Xi Sine Wave Inverter is not intended for use by persons (including children) with reduced physical, sensory, or mental capabilities or lack of experience and knowledge, unless they have been given supervision or instruction concerning use of the appliance by a person responsible for their safety. Children should be supervised to ensure that they do not play with the appliance.

**Failure to follow these instructions can result in minor or moderate injury.**



## Precautions When Working With Batteries

**Important:** Battery work and maintenance must be done by qualified personnel knowledgeable about batteries to ensure compliance with battery handling and maintenance safety precautions.

### **WARNING**

#### **BURN FROM HIGH SHORT-CIRCUIT CURRENT, FIRE AND EXPLOSION FROM VENTED GASES HAZARDS**

- Always wear proper, non-absorbent gloves, complete eye protection, and clothing protection. Avoid touching your eyes and wiping your forehead while working near batteries. See note #4.
- Remove all personal metal items, like rings, bracelets, and watches when working with batteries. See notes #5 and #6 below.
- Never smoke or allow a spark or flame near the engine or batteries.

**Failure to follow these instructions can result in death or serious injury.**

#### **NOTES:**

1. Mount and place the Freedom Xi Sine Wave Inverter unit away from batteries in a well ventilated compartment.
2. Always have someone within range of your voice or close enough to come to your aid when you work near a lead-acid battery.
3. Always have plenty of fresh water and soap nearby in case battery acid contacts skin, clothing, or eyes.
4. If battery acid contacts skin or clothing, wash immediately with soap and water. If acid enters your eye, immediately flood it with running cold water for at least twenty minutes and get medical attention immediately.

5. Use extra caution to reduce the risk of dropping a metal tool on the battery. It could spark or short circuit the battery or other electrical parts and could cause an explosion.
6. Batteries can produce a short circuit current high enough to weld a ring or metal bracelet or the like to the battery terminal, causing a severe burn.
7. When removing a battery, always remove the negative terminal from the battery first for systems with grounded negative. If it is grounded positive, remove the positive terminal first. Make sure all loads connected to the battery and all accessories are off so you don't cause an arc.

## Precautions When Placing the Inverter

### **WARNING**

#### **FIRE HAZARD**

Do not install the inverter or any part of its supplied wiring in engine compartments.

**Failure to follow these instructions can result in death or serious injury.**

### **CAUTION**

#### **BURN HAZARD**

Avoid touching the external surfaces - heatsink may be hot.

**Failure to follow these instructions can result in minor or moderate injury.**

### **NOTICE**

#### **RISK OF DAMAGE TO THE INVERTER**

- Never allow battery acid to drip on the inverter when reading gravity, or filling battery.
- Never place the Freedom Xi Sine Wave Inverter unit directly above batteries; gases from a battery will corrode and damage the inverter.
- Do not place a battery on top of the inverter.

**Failure to follow these instructions can damage the unit and/or equipment.**

## Regulatory

The Freedom Xi Sine Wave Inverter is certified to appropriate US and Canadian standards. For more information see “Regulatory Approvals” on page 33.

The Freedom Xi Sine Wave Inverter is intended to be used for mobile or commercial applications. This inverter is designed for marine applications only when additional drip protection is installed in certain orientations. See the section on Specifications for information.

## FCC Information to the User

This equipment has been tested and found to comply with the limits for a Class B digital device, pursuant to part 15 of the FCC Rules. These limits are designed to provide reasonable protection against harmful interference in a residential installation. This equipment generates, uses, and can radiate radio frequency energy and, if not installed and used in accordance with the instructions, may cause harmful interference to radio communications.

However, there is no guarantee that interference will not occur in a particular installation. If this equipment does cause harmful interference to radio or television reception, which can be determined by turning the equipment off and on, the user is encouraged to try to correct the interference by one or more of the following measures:

- Reorient or relocate the receiving antenna.
- Increase the separation between the equipment and receiver.
- Connect the equipment into an outlet on a circuit different from that to which the receiver is connected.
- Consult the dealer or an experienced radio/TV technician for help.

 <b>CAUTION</b>
Unauthorized changes or modifications to the equipment could void the user's authority to operate the equipment.



# Contents

Important Safety Instructions . . . . .	iii
Materials List. . . . .	1
Safety Instructions. . . . .	2
Installation Tools and Materials . . . . .	3
High Level Overview of Installation Steps . . . . .	4
Basic Installation Procedures . . . . .	5
Marine Installation . . . . .	29
Specifications . . . . .	32

---



# Materials List

The Freedom Xi base package includes the minimum following items:

- one Freedom Xi unit
- one set of owner's and installation guides
- one display panel with 7-inch (0.17 m) cable
- one communications cable (25 feet) (7.5 m)
- two DC terminal covers
- two strain-relief bushings
- one GFCI cover plate
- one pair AC compartment cover plates
- one display panel blanking plate (not shown)
- one display panel mounting bezel (not shown)
- one set of lock washers and nuts (not shown)

**NOTE:** If any of the items are missing, contact Xantrex or any authorized Xantrex dealer for replacement. See "Contact Information" on page i.

Other Freedom Xi OEM models may include other DC and/or AC connectors.

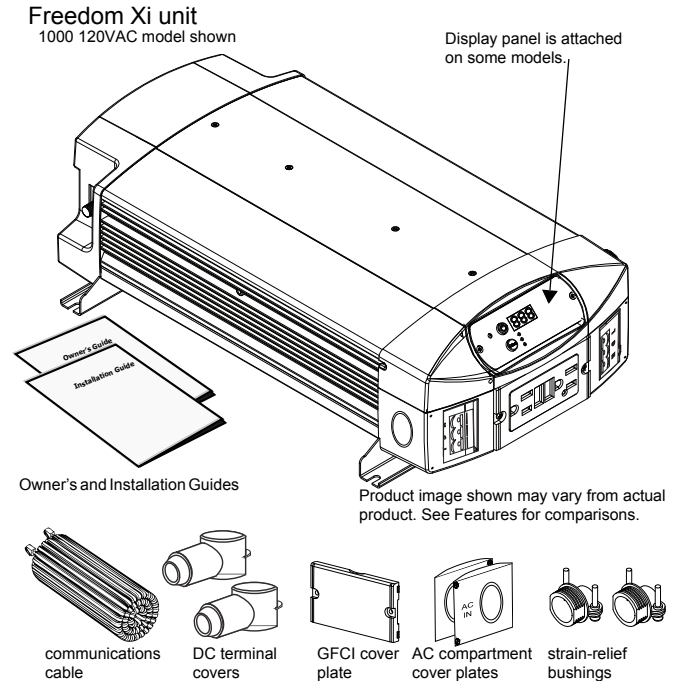

**Figure 1** What's In The Box

This guide for use by qualified personnel only.

# Safety Instructions

## Before You Begin the Installation

Before beginning your installation:

- Read the entire Installation Guide so you can plan the installation from beginning to end.
- Assemble all the tools and materials you require for the installation.
- Review the Important Safety Instructions on page iii.
- Be aware of all safety and electrical codes which must be met.

### **WARNING**

#### **ELECTRICAL SHOCK AND FIRE HAZARD**

- All wiring should be done by qualified personnel to ensure compliance with all applicable installation codes and regulations.
- Disconnect all AC and DC power sources.
- Disable and secure all AC and DC disconnect devices and automatic generator starting devices.

**Failure to follow these instructions can result in death or serious injury.**

## Installation Codes

Governing installation codes vary depending on the specific location and application of the installation. Some examples include the following:

- The U.S. National Electrical Code (NEC)
- The Canadian Electrical Code (CEC)
- The U.S. Code of Federal Regulations (CFRs)
- Canadian Standards Association (CSA) and the RV Industry Association (RVIA) for installations in RVs
- The American Boat and Yacht Council (ABYC) for Marine installations in the U.S.

It is the installer's responsibility to ensure that all applicable installation requirements are met.



# Installation Tools and Materials

You will need the following to install the Freedom Xi:

- Wire stripper
- Mounting screws or bolts
- #2 Phillips screwdriver
- 3.5mm slot long neck screwdriver for WAGO<sup>1</sup> terminals
- Wrench for DC terminals (1/2" or adjustable)
- AC cable (that is, two-conductor-plus-ground cable), sized appropriately for load and application
- Wire nuts or crimp connectors for AC wire and appropriate tools
- Two 1/2" strain-relief bushings (supplied) for AC cables
- DC cable, sized appropriately for load and application
- Lugs for DC cables to fit 5/16" DC stud terminals as well as appropriate tools (like a crimping tool)
- AC and DC disconnects and over-current protective devices

---

1. WAGO® manufactures connection devices such as terminal blocks and related accessories. Many Freedom Xi models use WAGO terminal blocks as AC input and output connections.

# High Level Overview of Installation Steps

Installing the Freedom Xi includes the following steps.

1. Ensure that power sources are OFF, like opening the DC disconnect switch and opening circuit breakers on the AC source panel.
2. Mount the inverter securely and permanently in one of the acceptable orientations.
3. Connect the Equipment Grounding Terminal to the equipment ground bus.
4. Connect the AC input wiring to the AC source panel.
5. Connect the AC output wiring to the AC load panel.
6. Connect one end of the DC negative cable to the negative terminal of the battery and the other end to the negative terminal of the unit.
7. Install an appropriately sized fuse and DC disconnect in the positive cable.
8. Connect the DC positive cable to the positive terminal of the battery and to the positive terminal of the unit.
9. Close the DC disconnect switch. Close the circuit breakers on the AC source panel.

Do not proceed with installation until you have read “Safety Instructions” on page 2.

# Basic Installation Procedures

This section provides sample installation information as a guide for your installation. For your convenience, the overall procedure is divided into these main steps:

- ❑ Step 1: Designing the Installation on page 6
- ❑ Step 2: Choosing a Location for the Unit on page 12
- ❑ Step 3: Mounting the Unit on page 13
- ❑ Step 4: Connecting the AC Input Wires on page 15
- ❑ Step 5: Connecting AC Output to an Existing AC Circuit on page 18
- ❑ Step 6: Connecting the DC Cables on page 20
- ❑ Step 7: Mounting the Display Panel on page 26
- ❑ Step 8: Testing Your Installation on page 27

This guide for use by qualified personnel only.

## Step 1: Designing the Installation

Most Freedom Xi installations share common components, and some of these are briefly described in Figure 2.

Figure 2 shows some components and their relationship to each other in a typical recreational vehicle or fleet vehicle installation. Also, see “Marine Installation” on page 29.

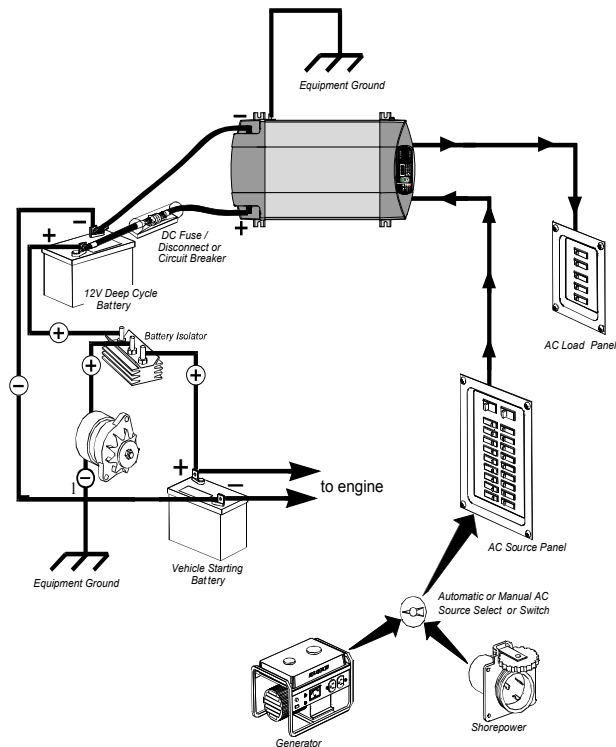

Figure 2 Typical Recreational Vehicle and Fleet Vehicle Installation

## AC Shore Power

A source of 120 volts AC 60Hz sine wave alternating current provides energy to pass power through to AC loads. This source is usually the utility grid (power company) or an AC generator. An automatic or manual AC source selector switch can be used to switch between the multiple sources of shore power to the Freedom Xi system.

The AC source feeding the Freedom Xi must have the neutral conductor bonded to ground. When the inverter passes shore power through, it will lift the bonding relay on the output and will rely on the input being bonded in order to ensure that the power delivered to a sub panel is properly bonded. See “AC Output Neutral Bonding” on page 9 for more information on bonding relay operation.

**Important:** Throughout this manual, the term “shore power” refers to AC input power from a utility grid, generator, or other AC source.

## AC Disconnect and Over-Current Protection Device

Most safety requirements and electrical codes require the Freedom Xi’s AC and DC inputs and outputs to be provided with over-current protection (such as circuit breakers or fuses) and disconnect devices.

**AC Input:** The circuit breaker or fuse (connected through hard wiring) that is used to supply the Freedom Xi must be rated at no more than 30A and must be approved for use on 120 volts AC branch circuits. The wire used between the breaker and the Freedom

Xi input must be sized adequately to carry current up to the rating of the input breaker and in accordance with the electrical codes or regulations applicable to your installation.

**AC Output:** The circuit breaker or fuse must be rated at no more than the rating of the input breaker in the installation and must be approved for use on 120 volts AC branch circuits. The wire used between the Freedom Xi and the AC output breaker must be of adequate size to match the AC input circuit breaker’s rating. The wiring from each AC output breaker to each of the loads must be adequately sized to carry the current rating of the individual AC output breaker.

**Disconnect Devices:** Each system requires a method of disconnecting the AC circuits. If the over-current protection devices are circuit breakers, they will also serve as the disconnects. If fuses are used, separate AC disconnect switches will be needed ahead of the fuses. These will have to be a branch circuit rated for 120 volts AC and have an appropriate current rating.

## AC Distribution Panels

Most systems incorporate distribution centers both ahead of the Freedom Xi (the AC source panel) and between the Freedom Xi and the loads (the AC load panel). An AC source panel includes a main circuit breaker, which serves as over-current protection and as a disconnect for the AC shore power supply line. Additional circuit breakers serve individual circuits, one of which serves the Freedom Xi. The AC load panel can incorporate an AC output circuit breaker and breakers for individual load circuits.

### **NOTICE**

#### **RISK OF DAMAGE TO THE INVERTER**

Do not connect the Freedom Xi to a 120/240V, 3-pole, 4-wire circuit.

**Failure to follow these instructions can damage the unit and/or equipment.**

## AC Cabling

AC cabling includes all the wires and connectors between the AC source and the Freedom Xi, as well as all cabling between the Freedom Xi and the AC output panels, circuit breakers, and loads. The type and size of the wiring varies with the installation and load. For example, in high vibration environments, such as marine or RV applications, wire nuts may not be acceptable, so crimp splices would be required. In other applications, flexible multiple-strand wire may be required. Installation codes usually specify solid or stranded, overall size of the conductors, and type and temperature rating of the insulation around the wire.

AC breakers and fuses must be sized to adequately protect the wiring that is installed on the input and output AC circuits of the Freedom Xi. All breakers and wiring must be sized and connected in accordance with the electrical codes or regulations applicable to your installation. Table 1 gives some examples of wiring sizes based on the U.S. National Electrical Code and the Canadian Electrical Code. These examples are based on using a two-conductor-plus-ground cable rated at 75 °C, and assuming an ambient temperature of up to 30 °C. Ensure that your breakers and fuses have suitable temperature ratings for your wiring. Other codes and regulations may also be applicable to your installation.

**Table 1** Required AC Wire Size vs Breaker Rating

Breaker Size (amps)	10A	15A	20A	30A
Minimum Wire Size	14AWG	14AWG	12AWG	10AWG

## AC Output Neutral Bonding

The neutral conductor of the Freedom Xi's AC output circuit (that is, AC Output Neutral) is automatically connected to the safety ground during inverter operation. **When AC utility power is present this connection is not present, so that the utility neutral (that is, AC Input Neutral) is only connected to utility ground at your source. This conforms to the National Electrical Code (NEC), which requires that separately derived AC sources (such as inverters and generators) have their neutral conductors tied to ground in the same way that the neutral conductor from the utility is tied to ground in only one place.** Check the regulations for your specific application to ensure that the installation will comply with the necessary requirements. In other words, the AC Input Neutral and Output Neutral must be isolated from each other.

## AC Grounding

As per UL458 SA29.5, for all permanently connected marine inverters: The Freedom Xi models should be connected to a grounded, metal, permanent wiring system. Also, make sure that an AC ground wire is connected to the AC ground terminal on the unit. Do not just connect the line and neutral wires.

All connections to the unit should comply with all local codes and ordinances.

This guide for use by qualified personnel only.

## DC Cabling

This includes all the cables and connectors between the batteries, the DC disconnect and over-current protection device, and the Freedom Xi. Most mobile installations require multi-strand insulated cables for flexibility and durability in high vibration environments and require disconnects and over-current devices. Electrical wiring sizes in North America are indicated by AWG notation. In other parts of the world, the metric system is used. Under the AWG standard, a larger gauge number indicates a smaller wire diameter. Wire size is usually marked on the larger sized cables. Table 2 specifies the minimum recommended DC cable size and maximum fuse size for the Freedom Xi. **The DC cables must be copper and must be rated 75 °C minimum.** The cables should be terminated with lugs that fit the DC stud terminals snugly (5/16" hole size).

**Table 2** Recommended Cable and Fuse Sizes

Inverter	Cable Length: Battery to Inverter (one way)	Minimum Cable Size	Maximum battery Fuse Size
Freedom Xi 1000 120VAC	Less than 5 feet (1.5 meters)	No. 2 AWG	150 Adc
Freedom Xi 2000 120VAC		No. 2/0 AWG	250 Adc

**Note:** It is not recommended using a cable longer than 5 feet (1.5 meters) in each direction. North American cable sizes above are based on the US National Electrical Code Table 310.17 - 75 °C cables, assuming an ambient temperature of 30 °C cables.

**Important:** Using the correct cable size is critical to achieving the rated performance of the Freedom Xi unit. When starting a heavy load the Freedom Xi can draw current surges from the battery of up to 400A. If the DC wiring is too small the voltage drop from this surge will result in a voltage at the Freedom Xi terminals that is too low for the Freedom Xi to operate correctly. The Freedom Xi may appear to operate correctly with smaller cables until a heavy load such as a microwave or refrigerator attempts to start - then the unit may work correctly sometimes and not work correctly other times.



## DC Disconnects and Over-Current Devices

The DC circuit from the battery to the Freedom Xi must be equipped with a disconnect and over-current device. This usually consists of a circuit breaker, a “fused-disconnect”, or a separate fuse and DC disconnect. Do not confuse AC circuit breakers with DC circuit breakers. They are not interchangeable. The rating of the fuse or breaker must be matched to the size of cables used in accordance with the applicable installation codes. The breaker or disconnect and fuse should be located as close as possible to the battery, in the positive cable. Applicable codes may limit how far the protection can be from the battery.

## Batteries

The Freedom Xi uses 12-volt battery banks. Every Freedom Xi system requires a deep-cycle battery or group of batteries that provide the DC current that the Freedom Xi converts to AC.

## Ground Fault Circuit Interrupters (GFCIs)

A GFCI is a device that de-energizes a circuit when a current to ground exceeds a specified value that is less than that required to blow the circuit breaker. GFCIs are intended to protect people from electric shocks and are usually required in wet or damp locations.

Installations in marine and recreational vehicles require GFCI protection of branch circuits connected to the AC output of the Freedom Xi.

The following GFCIs will work correctly with the Freedom Xi. Here are the recommendations:

Make	Model
Hubbell	GF15WLA
Leviton	N7599
Pass & Seymour	1595

## Step 2: Choosing a Location for the Unit

### **WARNING**

#### **FIRE AND EXPLOSION HAZARDS**

- Do not install the Freedom Xi in compartments containing batteries or flammable materials, or in locations that require ignition-protected equipment. This includes any space containing gasoline-powered machinery, fuel tanks, or joints, fittings, or other connections between components of the fuel system. This equipment contains components that tend to produce arcs or sparks.
- Do not cover or obstruct the ventilation openings. Do not install the Freedom Xi in a zero-clearance compartment. Overheating may result.

**Failure to follow these instructions can result in death or serious injury.**

The Freedom Xi should only be installed in locations that meet the following requirements:

- Dry.** Do not allow water or other fluids to drip or splash on the Freedom Xi. **Do not mount the Freedom Xi in an area subject to splashing water or bilge water.**
- Cool.** Normal air temperature should be between 32 °F and 104 °F (0 °C and 40 °C)—the cooler the better.
- Ventilated.** Allow at least 5 inches of clearance at the DC end of the Freedom Xi for air flow, 1 inch on each side, and 2 inches at the AC end. The more clearance for ventilation

around the unit, the better the performance. Do not allow the ventilation openings on the ends of the unit to become obstructed.

- Safe.** Do not install the Freedom Xi in the same compartment as batteries or in any compartment capable of storing flammable liquids like gasoline.
- Close to the battery compartment and the AC source and load panels.** Avoid excessive cable lengths (which reduce input and output power due to wire resistance). Use the recommended cable lengths and sizes, especially between the battery banks and the Freedom Xi.
- Protected from battery acid and gases.** Never allow battery acid to drip on the Freedom Xi or its wiring when reading specific gravity or filling the battery. Also do not mount the unit where it will be exposed to gases produced by the batteries. These gases are very corrosive, and prolonged exposure will damage the Freedom Xi.

## Step 3: Mounting the Unit

### To mount the Freedom Xi:

1. Remove the Freedom Xi from its shipping container, verify that all components are present, and record relevant product information on “Information About Your System” in the Owner’s Guide.
2. Select an appropriate mounting location and orientation. (See Figure 3 below.) To meet regulatory requirements, for use in on-land applications, the Freedom Xi must be mounted in one of the following orientations:
  - Under a horizontal surface (see 1)
  - In a horizontal position on a vertical surface (see 2)

**NOTE:** For marine installations, only this orientation is allowed, due to the probability of moisture finding access into the enclosure.

- On a horizontal surface (see 3)

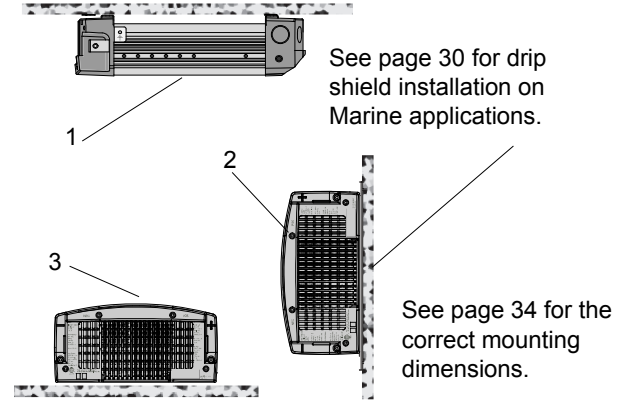

**Figure 3** Approved Mounting Orientations

3. Mark the desired number of mounting holes on the wall using measurements from the Freedom Xi “Dimensions for Mounting” on page 34 and pilot-drill the mounting holes.
4. Fasten the Freedom Xi to the mounting surface. If you are mounting the unit on a wall or bulkhead, use #12 or #14 pan-head wood or sheet metal screws to secure it to the framing behind the wall or bulkhead. Alternatively, use nut inserts and 1/4"-20 machine screws.

This guide for use by qualified personnel only.

## Connecting the Equipment Ground

### **⚠ WARNING**

#### **FIRE HAZARD**

Never operate the Freedom Xi without properly connecting the equipment ground. A fire hazard could result from improper grounding.

**Failure to follow these instructions can result in death or serious injury.**

The Freedom Xi has a ground stud on the side of the unit as shown in Figure 4. Follow the guidelines in “Grounding Locations” to connect the inverter’s chassis to the ground.

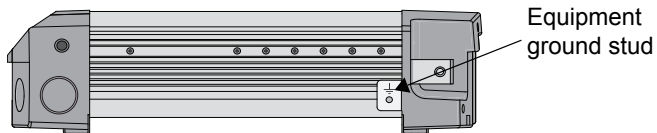

**Figure 4** DC Panel Connections

## Grounding Locations

You must connect the equipment ground stud to a grounding point—usually the vehicle’s chassis or DC negative bus ground—using recommended copper wire (if insulated then green insulation with or without one or more yellow stripes) or larger.

For recommended equipment ground cable size, see below.

**Table 3** Recommended Equipment Ground Cable size

<b>Application</b>	<b>Minimum equipment ground cable size (Stranded cable is recommended)</b>
Recreational Vehicle <sup>a</sup>	No. 8 AWG (All models)
Marine <sup>b</sup>	No. 3 AWG (Freedom Xi 1000) No. 1/0 AWG (Freedom Xi 2000)

**NOTE:** There are no restrictions on length for the equipment ground cable.

a. Based on US National Electrical Code NFPA70, Article 551, par. 551-20c.

b. Based on ABYC E-11 11.18.

In general, the equipment ground cable size must not be smaller than one AWG size than the supply cable.

## Step 4: Connecting the AC Input Wires

### **WARNING**

#### **FIRE, SHOCK, AND ENERGY HAZARDS**

Make sure wiring is disconnected from all electrical sources before handling. All wiring must be done in accordance with local and national electrical wiring codes. Do not connect the output terminals of the Freedom Xi to any incoming AC source.

**Failure to follow these instructions can result in death or serious injury.**

### General AC Wiring Considerations

**AC Wiring Connectors** Where applicable, connect AC wires with crimp-on splice connectors. The amount of insulation you strip off individual wires will be specified by the connector manufacturer and is different for different types of connectors.

**AC and DC Wiring Separation** Do not mix AC and DC wiring in the same conduit or panel. Where DC and AC wires must cross, make sure they do so at 90° to one another. Consult applicable codes for details about DC and AC wiring in close proximity to each other.

**AC Wiring and GFCIs** You can plug loads, 15 amps for 1000-watt models and 20 amps for 2000-watt models, directly into the GFCI receptacle on the front panel of the Freedom Xi. You can also connect the inverter to an existing AC installation and then plug loads into GFCI receptacles connected to that circuit.

If you plan to use the Freedom Xi with the GFCI installed on the unit, proceed to “Step 6: Connecting the DC Cables” on page 20.

AC wiring includes all the wires and connectors between the AC source and the Freedom Xi and all wiring between the inverter, the AC panels, circuit breakers, and the GFCIs. The type and size of the wiring varies with the installation and load. For some RV applications, flexible multiple-strand wire is required.

AC wiring must be sized appropriately to carry full load current on the input and output AC circuits in accordance with the electrical codes or regulations applicable to your installation. Table 4 is based on the U.S. National Electrical Code and the Canadian Electrical Code, assuming two-conductor-plus-ground cable, using 75 °C wiring, at an ambient temperature of 30 °C. Other codes and regulations may be applicable to your installation.

This guide for use by qualified personnel only.

**Table 4** Required AC wire size vs. required breaker rating

	Required Breaker Size (amps)	Required Wire Size
<b>Freedom Xi 1000 120VAC</b>	30 A maximum	10 AWG
<b>Freedom Xi 2000 120VAC</b>	30 A maximum	10 AWG

The AC input terminal is located on the front panel and is labeled properly as **AC IN** or **AC INPUT**. Depending on the model, you can have three types of wire terminals.

The Standard models come with WAGO-type terminals where individual wires can be attached securely.

***NOTICE***

**EQUIPMENT DAMAGE**

Make sure the wires are connected properly. The AC wiring terminal blocks are split into input and output sections.

**Failure to follow these instructions can damage the unit and/or equipment.**

When making the AC input and AC output connections, observe the correct color code for the appropriate AC wire, as described in Table 5.

**Table 5** Color codes for typical AC wiring

Color	AC Wire
Black	Line
White	Neutral
Green or bare copper	Ground (Earth)

**NOTICE****REVERSE POLARITY DAMAGE**

Make sure the wires are connected properly. Improper connections (connecting a line conductor to a neutral conductor, for example) will cause the Freedom Xi to malfunction and may permanently damage the inverter. Damage caused by a reverse polarity connection is not covered by your warranty.

**Failure to follow these instructions can damage the unit and/or equipment.**

**Wiring Knockouts** When installing wires to AC terminals, always remove the appropriate wiring knockouts (there are two on each side, two on each AC compartment cover plate) and install the proper strain-relief bushings.

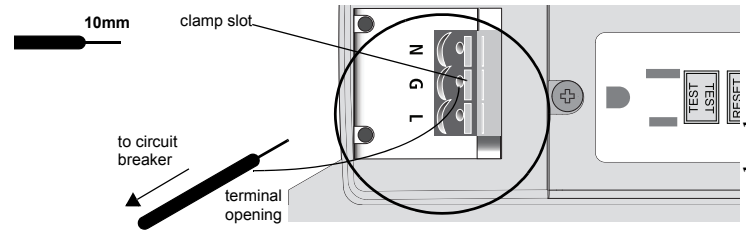
**AC Input Connections for Standard Models**

1. Ensure AC and DC power sources are turned off.
2. Install the required circuit breaker in the AC distribution panel supplying AC power to the unit.
3. Remove the AC compartment cover plate.
4. Strip a single strand (e.g. Romex®)<sup>1</sup> AC input wire, as appropriate.
5. Locate the Line, Ground and Neutral terminals on the AC input terminal labeled as **L**, **G**, and **N** respectively.
6. Using a 3.5mm slot long neck screwdriver, open the WAGO cage clamp by inserting the tool in the clamp slot and gently pulling the screwdriver handle forward, for Ground terminal.
7. Insert Ground AC wire into Ground terminal slot on the unit.
8. Repeat steps 6 and 7 for Line and Neutral connections.
9. Replace the AC compartment cover plate onto the unit.
10. Connect the other end of the wires to the circuit breaker in the AC distribution panel supplying AC power to the unit.

<sup>1</sup> Romex is a brand name owned by Southwire and used here as an example but not as an endorsement of a particular brand.

## Step 5: Connecting AC Output to an Existing AC Circuit

**⚠ WARNING**

**FIRE, SHOCK, AND ENERGY HAZARDS**

Make sure wiring is disconnected from all electrical sources before handling. All wiring must be done in accordance with local and national electrical wiring codes.

**Failure to follow these instructions can result in death or serious injury.**

**NOTICE**

**EQUIPMENT DAMAGE**

Do not connect any AC source (such as a generator or utility power) to the AC wiring output of the Freedom Xi.

The Freedom Xi will not operate if its output is connected to AC voltage from another source, and potentially hazardous or damaging conditions may occur. These conditions can occur even if the inverter is off.

**Failure to follow these instructions can damage the unit and/or equipment.**

A manufacturer-tested and approved GFCI must be connected to the Freedom Xi AC output, and on every receptacle connected to the AC hard wired installation. Other types may fail to operate properly when connected to the Freedom Xi. Although you can reuse the factory-installed GFCI, the manufacturer has also tested and approved the following GFCIs for use with the Freedom Xi inverter. See “Ground Fault Circuit Interrupters (GFCIs)” on page 11.

Do not connect the Freedom Xi to an AC branch circuit that has high-power consumption loads.

The Freedom Xi will not operate electric heaters, air conditioners, stoves, and other electrical appliances that consume more than 1000 watts (Freedom Xi 1000 models) or 2000 watts (Freedom Xi 2000 models).



## AC Output Connections for the Standard Models

To make a permanent connection to existing AC wiring:

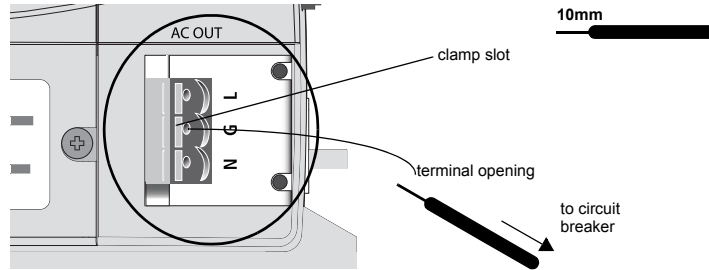

1. Ensure AC and DC power sources are turned off.
2. Install the required circuit breaker in the inverter distribution panel receiving AC power from the inverter.
3. Remove the AC compartment cover plate.
4. Strip a single strand (e.g. Romex) AC output wire, as appropriate.
5. Locate the Line, Ground and Neutral terminals on the AC OUT terminal labeled as **L**, **G**, and **N** respectively.
6. Using a 3.5mm slot long neck screwdriver, open the WAGO cage clamp by inserting the tool in the clamp slot and gently pulling the screwdriver handle forward, for Ground terminal.
7. Insert Ground AC wire into Ground terminal slot on the unit.
8. Repeat steps 6 and 7 for Line and Neutral connections.
9. Replace the AC compartment cover plate.
10. Connect the other end of the wires to a circuit breaker in the inverter distribution panel.

## Step 6: Connecting the DC Cables

The following instructions only apply to the standard models.

### **NOTICE**

#### **REVERSE POLARITY DAMAGE**

Check cable polarity at both the battery and the Freedom Xi before making the final DC connection. Positive must be connected to positive; negative must be connected to negative.

Reversing the positive and negative battery cables will damage the Freedom Xi and void your warranty.

**Failure to follow these instructions can damage the unit and/or equipment.**

### **⚠ WARNING**

#### **FIRE HAZARD**

Use only copper wire rated 75 °C minimum. Make sure all DC connections are tight to a torque of 108–120 inch-pounds (12.2–13.6Nm). Loose connections will overheat.

**Failure to follow these instructions can result in death or serious injury.**

Follow the procedure given below to connect the battery leads to the terminals on the DC end. The cables should be as short as possible and large enough to handle the required current, in accordance with the electrical codes or regulations applicable to your installation. Table 2 on page 10 specifies the minimum DC cable size and maximum fuse size for the Freedom Xi.

Do not route your DC cables through an electrical distribution panel, battery isolator, or other device that will cause additional voltage drops.

Figure 5 shows the DC end for your reference.

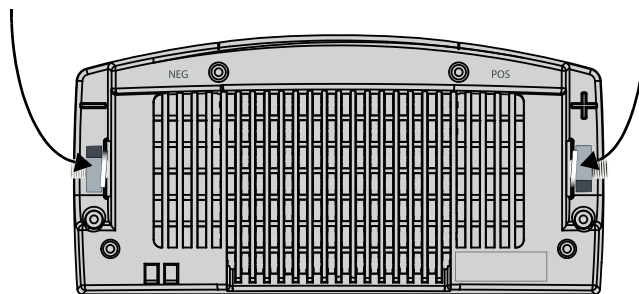

**Figure 5** DC End for Standard Models

#### **To make the DC connections**

Refer to Figure 6.

1. Make sure the inverter is off and no AC or DC is connected to the unit.
2. Remove the nuts and washers from the Freedom Xi positive and negative DC terminals.

3. Strip 1/2 inch (13 mm) to 3/4 inch (19 mm) insulation from one end of each cable. The amount stripped off will depend on the terminals chosen.
4. Attach the connectors that will secure the cables to the battery, to the disconnect/battery selector switch, and the fuse block. The connectors you use must create a permanent, low-resistance connection. If crimp connectors are required, it is recommended to use approved and certified connectors, and to use the tool recommended by the terminal manufacturer. Make sure no stray wires protrude from the connector or terminal. (You may find it more convenient to have the crimp connectors attached by the company that sells you the cable and/or connectors.)
5. For each cable end that will be connected to the inverter, strip 1/2 inch (13 mm) to 3/4 inch (19 mm) of insulation from the cable. The amount stripped off will depend on the terminals chosen.
6. Thread a supplied DC terminal cover over the positive and negative cables. The red cover goes on the positive cable; the black cover on the negative cable.
7. Attach the connector that will join the cable to the inverter DC terminal.
8. Install a fuse and fuse holder in the cable that will be used for the positive side of the DC circuit. The fuse must:
  - be as close to the battery positive terminal as possible
  - be rated for DC circuits
  - have an Ampere Interrupting Capacity (AIC) that exceeds the short-circuit current available from the battery (that is, Class T fuse)
9. To prevent sparking when making the connection, ensure the disconnect/battery selector switch is off.
10. Attach the connector on the positive cable to the positive DC terminal on the inverter.
11. Install the lock washer and nut that are supplied with the inverter. Tighten the nut to a torque of 108–120 in-lbf (12.2–13.6 N-m). Make the connection snug enough so the ring terminal does not move around on the DC terminal, but do not overtighten. See Figure 6, “DC Cable Connections” on page 22.

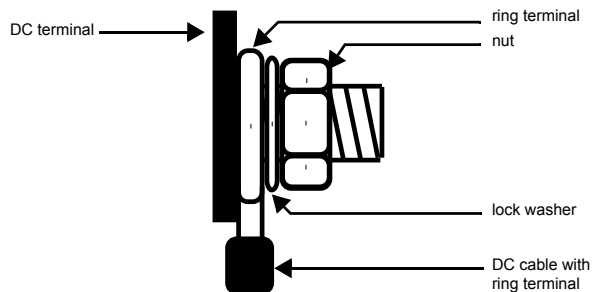

**Figure 6** DC Cable Connections

**NOTICE**

**EQUIPMENT DAMAGE**

Tighten the nuts on terminals properly. Loose connections cause excessive voltage drop and may cause overheated wires and melted insulation.

Do not over-tighten the nut on the DC input terminals. Damage to the DC input terminals may result. The maximum torque setting is **120 in-lbf (13.6 N-m)**.

**Failure to follow these instructions can damage the unit and/or equipment.**

**NOTICE**

**REVERSE POLARITY DAMAGE**

Check cable polarity at both the battery and the Freedom Xi before making the final DC connection. Positive must be connected to positive; negative must be connected to negative.

Reversing the positive and negative battery cables will blow a fuse in the Freedom Xi and void your warranty.

**Failure to follow these instructions can damage the unit and/or equipment.**

12. Before proceeding, double check that the cable you have just installed connects the positive DC terminal of the inverter to the disconnect/battery selector switch, fuse holder, and that the other end of the fuse holder is connected to the positive terminal of the battery.

**WARNING**

**FIRE HAZARD**

Do not complete the next step if flammable fumes are present. Explosion or fire may result if the disconnect/battery selector switch is not in the off position. Thoroughly ventilate the battery compartment before making this connection.

**Failure to follow these instructions can result in death or serious injury.**

13. Connect the cable from the negative post of the battery to the negative DC terminal of the inverter.
14. Install the lock washer and nut that are supplied. Tighten the nut to a torque of 108–120 in-lbf (12.2–13.6 N-m). Make the connection snug enough so the ring terminal does not move around on the DC terminal, but do not overtighten.
15. Slip the DC terminal covers over the Freedom Xi DC terminals.

## DC Grounding

### To connect the DC ground:

The equipment grounding lug on the DC end of the Freedom Xi is used to connect the chassis of the Freedom Xi to your system's DC negative connection or grounding bus point as required by electrical regulations. Use copper wire that is either bare or provided with green insulation. Do not use the DC Ground Lug for your AC grounding. See the AC wiring instructions in this section.

Follow the guidelines below that correspond to the specific type of installation. These guidelines assume you are using the DC supply cable and fuse sizes recommended in this manual. If you are using different sizes, refer to the applicable installation code for DC grounding details.

**Recreational Vehicle** Use 8AWG copper wire and connect it between the Chassis Ground lug and the vehicle's DC grounding point (usually the vehicle chassis or a dedicated DC ground bus).

**Marine** Use copper wire that is bare or has insulation rated minimum 105 °C, and connect it between the Chassis Ground lug and the boat's DC grounding bus or engine negative bus. For the Freedom Xi 1000 models, use a wire of gauge 4AWG minimum. For the Freedom Xi 2000 models, use a wire of gauge 1/0AWG minimum.

## Inverter Ignition Control (All Models)

The Freedom Xi can be wired to inhibit inverter operation in the absence of a vehicle's (or vessel's) ignition control signal. This feature can avoid unnecessary battery drain that would otherwise occur if the inverter was operated without a charging source such as the vehicle alternator. The feature is standard on the Freedom HF platform.

### To enable ignition control:

1. Ensure that AC and DC power are both OFF.
2. Ensure the vehicle's ignition is turned to OFF position. It is highly recommended to remove battery power by disconnecting the vehicle's battery cables. Refer to the vehicle's user manual for proper instructions on how to disconnect the battery cables.

## Basic Installation Procedures

3. Locate the vehicle's ignition control wire from the vehicle's ignition circuit. This wire must be fused appropriately at no more than five amps. Refer to the vehicle's user manual for guidance.
4. Using a #1 Phillips screw driver, remove the screw securing the DC wiring cover on the left hand side of the unit.

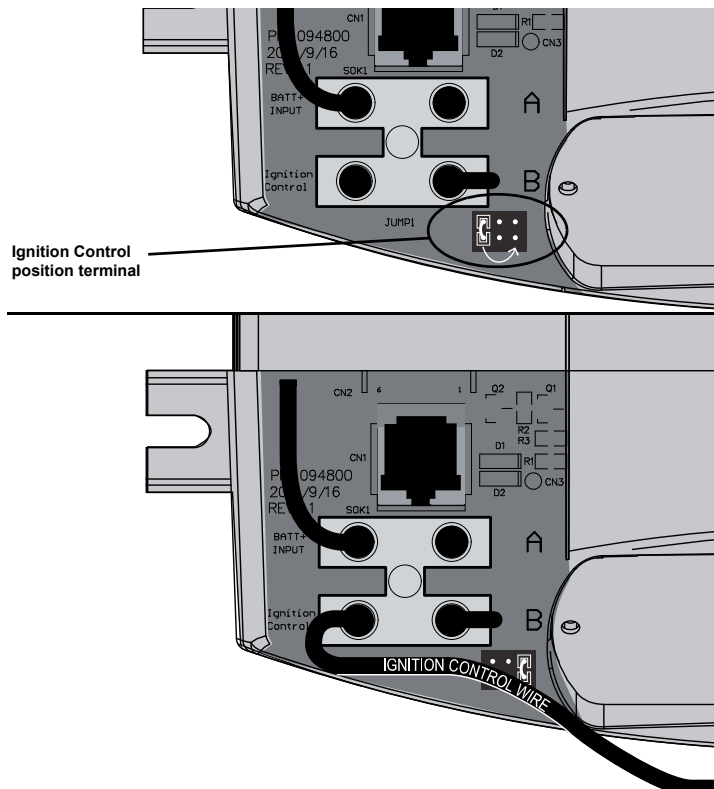

**Figure 7** Exposed Ignition Control Terminals

5. Remove the DC wiring cover to expose the ignition control terminals of the DC wiring compartment.
6. Move the jumper wire from the left-side position (factory installed) to the right-side position on the **Ignition Control** position terminal.  
The jumper wire, depending on which position it is installed, acts to disable (factory left-side position), lock-out (middle position), and switch to auto-on (right-side position) the ignition control. See “Description of Ignition Control Methods” on page 25 for more details.  
**NOTE:** Do not make any external connections to terminal **A**. This can result in non-warranty damage to the unit.
7. Route the ignition control wire to the left side of the display panel.
8. Replace the DC wiring cover onto the DC wiring compartment.  
The ignition control wire should pass-through the hole on the side of the DC wiring cover.

### Description of Ignition Control Methods

Off (Disabled)	This is the default position. In this position, there is no ignition control capability.
----------------	--

Ignition Lock-out	In this position, when ignition voltage is detected at the ignition input terminal, inverter mode remains on "standby" until the Power button on the front panel is pressed to turn on inverter power. When the ignition voltage stops, inverter power stops.
Ignition Auto-on	In this position, when ignition voltage is detected at the ignition input terminal, inverter power is automatically turned on. When the ignition voltage stops, inverter power stops.

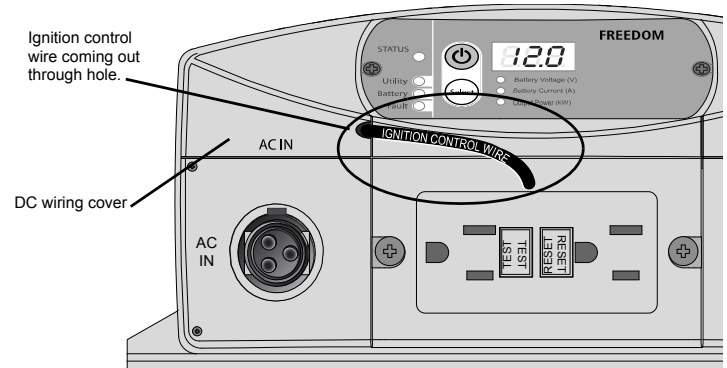

This guide for use by qualified personnel only.

## Step 7: Mounting the Display Panel

The communications cable supplied with the display panel is 25 feet (7.6 meters) long. If you want to replace the cable with one that is shorter, use a high quality, six-wire telephone extension cable.

Flush mounting the panel on a wall or bulkhead requires an opening that is approximately  $3.25 \times 1.25$  inches ( $8.25 \times 3.18$  cm). About 1.5 inches (3.81 cm) of free space is required within the wall to accommodate the depth of the panel. Be sure there is no wiring or other obstructions within the wall before you make an opening.

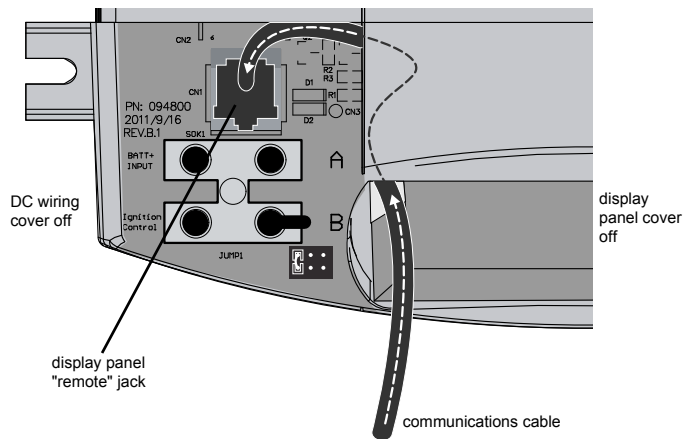

**Figure 8** Communications Cable

### To mount the display panel:

1. Choose a location that is dry, out of direct sunlight, free from corrosive or explosive fumes, and otherwise appropriate for mounting an electronic device.
2. Mark the mounting holes onto the mounting surface and the area to be cut away using the display panel itself as a guide.
3. Pilot-drill the mounting holes and cut out the hole in which the panel will be inserted.
4. Route the communications cable(s) inside the wall and through the opening.
5. Insert one of the cable's connectors in either jack on the bottom of the panel.
6. Place the panel in the opening and secure it with appropriate fasteners.
7. Route the communications cable to the Freedom Xi and insert the connector in the jack located near the battery select dip switch.

**Important:** Do not route the communications cable in parallel and in conduit with the AC and DC wires. In situations where the cable must cross with the AC and DC wires, make sure they cross at a 90° angle to each other.



## Step 8: Testing Your Installation

### **WARNING**

#### **ELECTRICAL SHOCK HAZARD**

Pressing the Inverter button to turn OFF the Freedom Xi inverter function on display panel does not disconnect DC or AC input power to the Freedom Xi. If shore power is present at AC input terminals, it will pass through to the AC output.

**Failure to follow these instructions can result in death or serious injury.**

There are two tests to be performed. The first test verifies that the Freedom Xi is inverting DC battery power and delivering AC power to its output.

The second test is intended for installations where AC input and output is hard wired to the Freedom Xi. This test verifies that the Freedom Xi transfers from inverter power to shore power when shore power is present.

**NOTE:** Shore power (pass-through) refers to the AC input power from a utility grid, generator or external AC source.

When you are ready to test your installation and operate the Freedom Xi, close the DC fuse and Disconnect or the DC circuit breaker to supply DC power to the Freedom Xi.

## Testing in Invert Mode

**To test the Freedom Xi in invert mode:**

1. For hard wired installations, ensure shore power is not present.
2. Press the Inverter button to turn the inverter on.  
The status LED on the display panel glows yellow and the LED display illuminates.
3. Plug an appliance within the power rating of the inverter into the Freedom Xi GFCI or an AC outlet hard wired to the Freedom Xi.
4. Turn the appliance on to verify that it operates.

If the appliance operates, your installation is successful. If your installation has AC input and output hard wired to the Freedom Xi, proceed to “Testing in Shore Power Mode”.

If the status LED on the display panel glows red, see the Troubleshooting chapter.

This guide for use by qualified personnel only.

## Testing in Shore Power Mode

### To test the Freedom Xi in shore power mode:

- ◆ With the appliance from the previous test still connected and operating, connect the shore power source.

The Freedom Xi transfers the appliances to shore power. The status LED on the display panel will change from yellow to a ten-second flashing yellow and then green.

If the appliance operates, your installation is successful.

---

**NOTE:** If the Inverter button on the Freedom Xi is turned ON, the Freedom Xi will automatically supply the appliances with inverter power if the shore power source fails or becomes disconnected.

If the Inverter button on the Freedom Xi is turned ON and shore power voltage is too low (less than 90 volts AC), the unit will transfer to inverter power to continue running your appliances.

---

**NOTE:** Whether or not the Inverter button is turned ON, shore power will pass through the Freedom Xi to the output when shore power is within normal operating range.

---

# Marine Installation

Figure 9 illustrates a typical marine installation with the following components:

1. AC power supplied from a shore power connector
2. An AC source panel that includes a Max 30A circuit breaker that supplies the Freedom Xi
3. An AC load panel with branch circuit breakers that supply only loads that run off the Freedom Xi
4. Engine negative bus / DC ground bus
5. DC power supplied by a battery bank and protected by a DC fuse in the positive cable
6. Battery isolator
7. DC alternator
8. Starting battery
9. Drip shield (see next page)

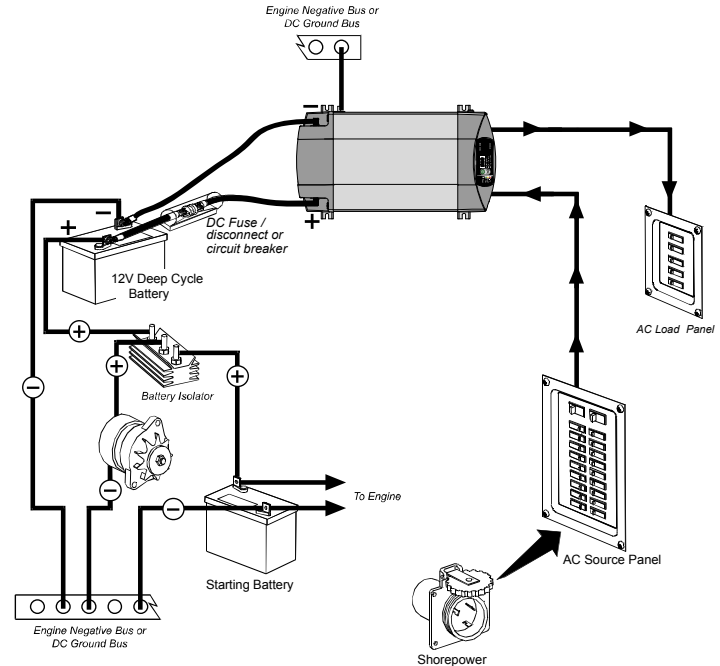

This guide for use by qualified personnel only.

Figure 9 Typical Marine Installation

## Drip Shield Installation

The drip shields help to protect the unit from dripping or splashing liquids, which will cause a shock hazard when moisture comes in contact with electrical circuits in the unit. The drip shields are especially useful in marine installations where water from condensation, rain, or sea may come into contact with the Freedom Xi.

**⚠ WARNING**

**ELECTRICAL SHOCK HAZARD**

Place this unit in normally dry areas only. Operating the unit under wet conditions may expose you to a shock hazard. Installing drip shields may not entirely protect you from this hazard. Do not operate the unit when it is wet.

**Failure to follow these instructions can result in death or serious injury.**

You may purchase the drip shield set by contacting customer support. When ordering, mention part number 808-1050.

### Different Views

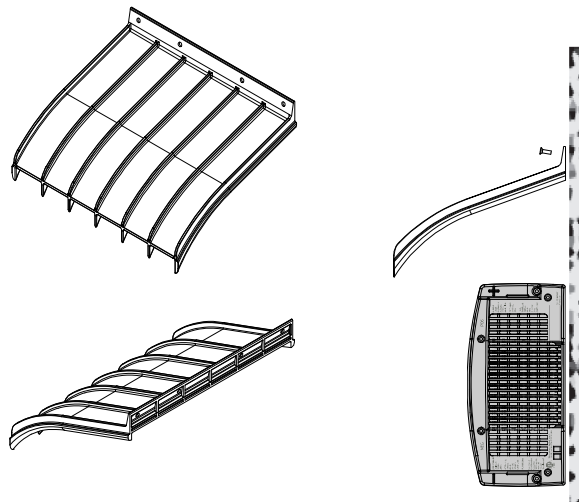

Drip Shield set part# 808-1050

**Figure 10** Drip Shields

**To install the drip shields:**

1. Gather the four screws needed to fasten a single drip shield to a wall.
2. Locate an appropriate setting for the drip shields above the Freedom Xi making sure you cover the entire width of the unit. You can overlay the shields as shown in Figure 11 below.
3. Fasten the screws through the holes in the drip shield into the wall. See Figure 10.

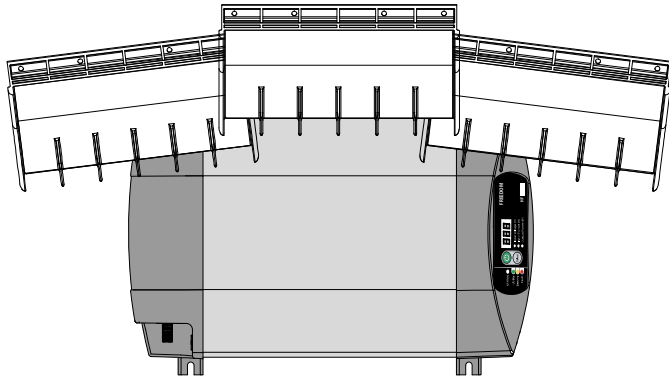

**Figure 11** Typical Drip Shield Placement on a Freedom Xi 2000

# Specifications

**NOTE:** Specifications are subject to change without prior notice.

Physical Specifications	Freedom Xi 1000	Freedom Xi 2000
L × W × H	19.2" (487mm) × 9.4" (240mm) × 4.7" (120mm)	19.2" (487mm) × 9.4" (240mm) × 4.7" (120mm)
Net Weight	11 lbs (5 kg)	14.4 lbs (6.5 kg)

Environmental Specifications	Freedom Xi 1000	Freedom Xi 2000
Ambient Temperature: Operating Temperature Range Storage Temperature Range	-4 –122 °F (-20 –50 °C), with output derated above 77 °F (25 °C) -40–158 °F (-40–70 °C)	
Humidity: Operation/Storage	5–95% RH, non-condensing	

System Specifications	Freedom Xi 1000	Freedom Xi 2000
Transfer relay rating	30A, 2.0hp (24A required derating by electrical code in North America)	
Transfer time (shore to inverter)	<40 milliseconds	
Transfer time (inverter to shore)	<40 milliseconds with a 20-second delay	
Transfer voltage (shore to inverter)	<95 V and >135 V	
Transfer voltage (inverter to shore)	<130 V and >100 V	
Cooling	Fan, activated by any of the following: •High internal temperature •High AC output power	

<b>DC Input</b>	<b>Freedom Xi 1000</b>	<b>Freedom Xi 2000</b>
Operating voltage range for all models	10.5–16.5 VDC (low limit) 11.8–16.5 VDC (mid limit) 12.1–16.5 VDC (high limit)	10.5–16.5 VDC (low limit) 11.8–16.5 VDC (mid limit) 12.1–16.5 VDC (high limit)
Safe non-operating voltage range	0–24 VDC	0–24 VDC
Nominal voltage for all models	12.5 VDC	12.5 VDC
Nominal current at full load	92 ADC	200 ADC

<b>AC Output</b>	<b>Freedom Xi 1000</b>	<b>Freedom Xi 2000</b>
Output voltage range	110–125 VAC	110–125 VAC
Continuous power	1.0kW @ 40 °C	2.0kW @ 25 °C
Continuous current	8.3 A	16.6 A
Surge power	2000 W	4000 W
Max short-circuit current	55 A peak	55 A peak
Frequency	60 Hz	60 Hz
GFCI protection for 120VAC models only	Yes	Yes
Wave shape	True Sine Wave	True Sine Wave
Peak efficiency	≥87%	≥87%
Full load efficiency	≥82%	≥82%

<b>Regulatory Approvals</b>	<b>Freedom Xi 1000</b>	<b>Freedom Xi 2000</b>
EMC and Safety	ETL listed to CSA 107.1 UL458 and UL458 Marine Supplement (drip shield with product number 808-1050 required) ABYC E11, A20, A25, A31	

This guide for use by qualified personnel only.

## Dimensions for Mounting

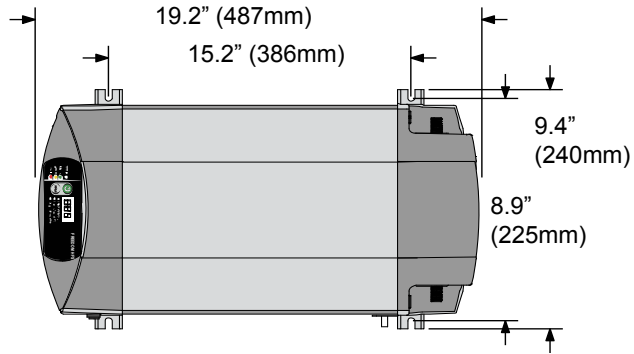





**Schneider Electric Solar  
Inverters USA Inc.**

+1 800 670 0707  
+1 408 987 6030  
[www.xantrex.com](http://www.xantrex.com)

975-0753-01-01

Printed in China