

SEAVIEW

ELEVATE YOUR ELECTRONICS

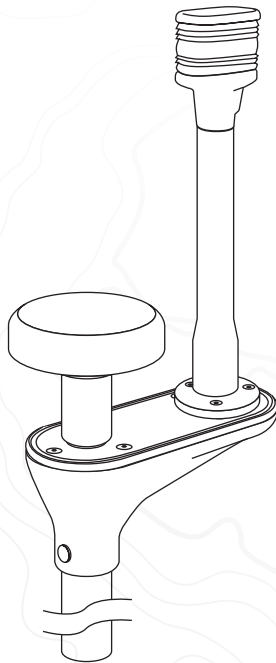

INSTALLATION INSTRUCTIONS

For Seaview Light Bar Top:

LTBU1A1197

Refer to website for most up to
date instructions and videos.

WWW.SEAVIEWGLOBAL.COM

PARTS INCLUDED

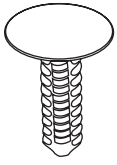

x2

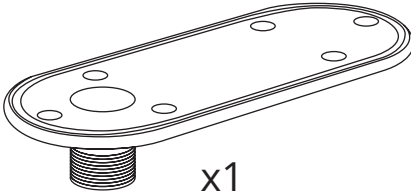

x1

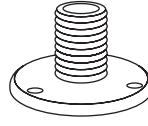

x2

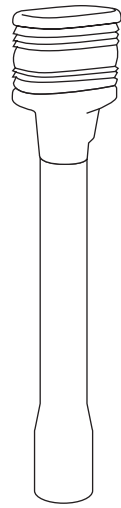

x1

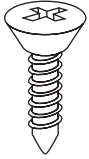

x6

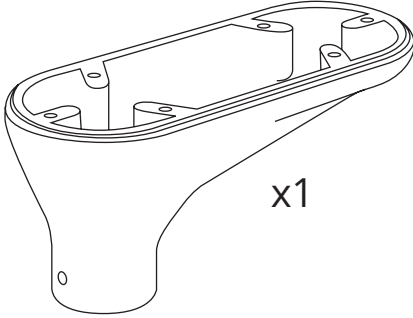

x1

TOOLS NEEDED

Sudbury Elastomeric Marine Sealant is recommended. To purchase call 800-655-7922 or visit www.seaviewglobal.com



1/16 inch = 5mm

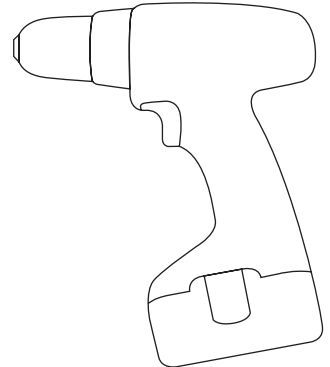

1 Drill a hole to run cables for the light. This may have already been done for you.

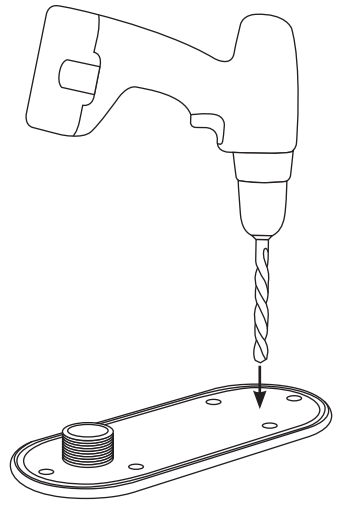

2 Apply marine adhesive sealant around the top of the Light bar as shown, then slide on to the Light Bar.

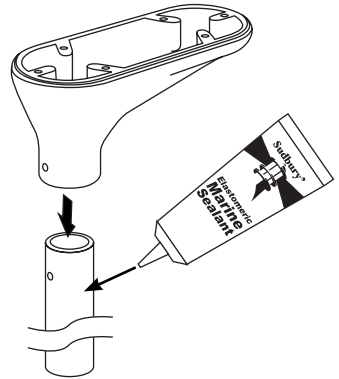

3 Apply marine adhesive sealant to the mounting holes. Then insert the two plastic rivets into holes as shown.

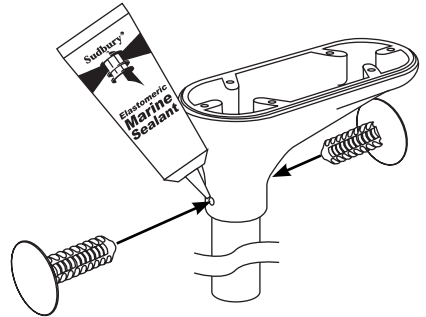

4 Apply marine adhesive sealant into the groove of as shown.

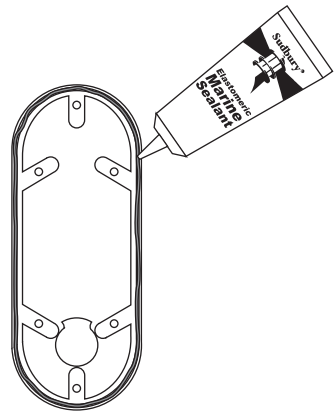

5 Apply marine adhesive sealant around the three holes for the light and the three holes for the GPS.

Then route all cabling through and secure the electronics.

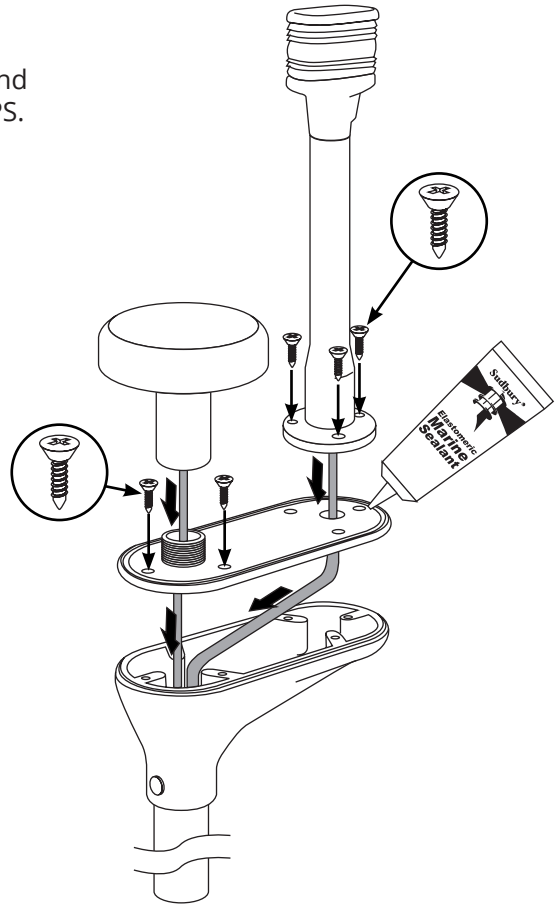

OPTIONAL ACCESSORIES

Call 800-655-7922 or visit www.seaviewglobal.com for available accessories.

SPREADER KIT

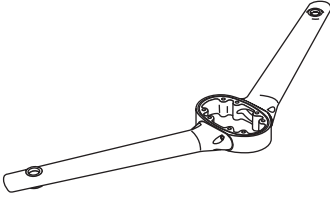

SP1-MOD

Allows user to mount GPS units or antennas onto a Seaview Modular Mount.

WEDGES

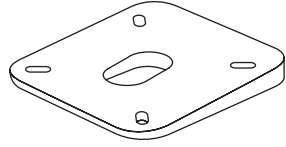

Compensates for plane angle.
Available in 2, 4 or 6 degree wedges.

HINGES

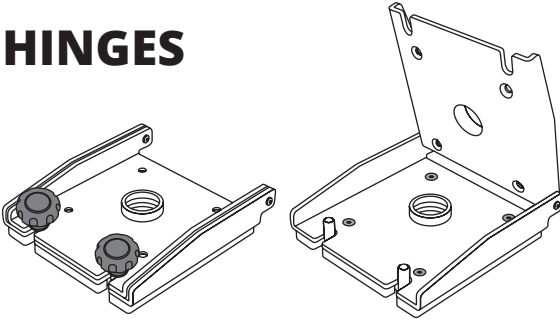

Seaview Hinge Adapters fold in any direction necessary for added height clearance.

PERKO®

Fig. Nos. 1183 Series Combination Masthead and All-Round White (Anchor) Lights.
Fig. Nos. 1196 Series Combination Masthead and All-Round White (Anchor) Lights.
Fig. Nos. 1197 Series Combination Masthead and All-Round White (Anchor) Lights.

The above lights are designed for use on sail or power driven vessels under 20 meters (65. 6 ft) in length, operating at a nominal 12 volt or 24 volt system. In order to comply with '72 COLREGS and U.S. Inland Navigation Rules', the following must be adhered to:

Mounting Information

Read all instructions before proceeding.

- 1). These instructions show the orientation of each light. For proper light selection, positioning and configuration, refer to A.B.Y.C. Standard A-16*, the '72 COLREGS and the U.S. Inland Navigation Rules'. These lights are supplied complete with 12 volt bulbs (Cat No. 0071DPOCLR, 12V, 10W), however, 24 volt bulbs (Cat No. 0072001CLR, 24V, 10W) are available for 24 volt systems.

- 2). These lights are designed to be mounted on a horizontal surface.

- 3). Cat. Nos. 1183DP0CHR, 1183DP0CHR, 1196DP1CHR, 1196DP1CHR, 1196DP2CHR and 1196DP2CHR: These lights are furnished for mounting such that the long dimension of the mounting base is parallel to the fore-aft centerline of the boat. If a mounting is desired such that the long dimension of the mounting base is perpendicular to the fore-aft centerline of the boat, substitute instruction d) below for instructions a) to c).

- a). Draw a 4 inch long reference line through the center of the selected mounting location and parallel to the fore-aft centerline of the boat.
- b). Cut out the mounting template below. Tape it on the mounting surface such that the reference line (drawn above) is directly underneath the reference line marked on the template.
- c). Drill 2 holes through the template to accommodate #8 round head mounting screws. Drill one 3/8 inch hole to accommodate the electric wiring. (Proceed with instruction #5 below).
- d). Special Instruction only for mounting with the long dimension of the mounting base perpendicular to the fore-aft centerline of the boat:

- 1). Draw a 4 inch long reference line through the center of the selected mounting location and perpendicular to the fore-aft centerline of the boat.
- 2). Remove the holding screw (see illustration) and rotate light assembly on the tube 90° in one direction or the other until a second hole appears on the tube. Re-insert the holding screw into the Light assembly such that it enters the new tube hole to anchor the assembly 90° from its original position.
- 3). Cut out the mounting template below. Tape it on the mounting surface such that the reference line (drawn above) is directly underneath the reference line marked on the template.
- 4). Drill 2 holes through the template to accommodate #8 round head mounting screws. Drill one 3/8 inch hole to accommodate the electrical wiring.

- 4). Cat. No. 1197000CHR: This light is furnished with a 3/4 inch tube and is designed to be mounted vertically into a 3/4 inch hole.
- 5). Attach supply connections to the light making sure to wire in accordance with both A.B.Y.C. Standard E4* and U.S. Coast Guard Safety Standards for Boat Electrical Systems (33 CFR 183)*.

The supply leads are coded as follows:

Wiring Diagram for Combination Masthead/Anchor Lights

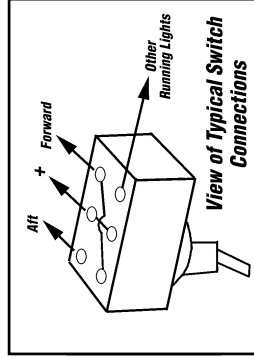
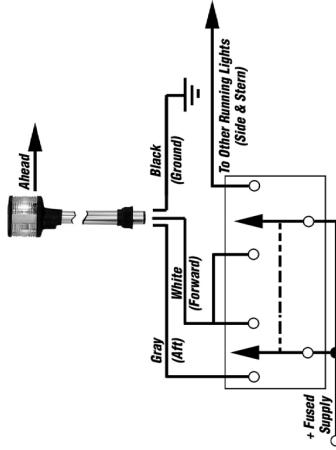

USCG APPROVAL
 33 CFR 183.810
Visibility: 3nm
 Tested By: IMANNA Labs.
 Date: 9/9/03
 Meets ABYC A-16

WHITE: Forward compartment (masthead light) positive lead supply.
 GRAY or RED: Aft compartment (when energized with the forward compartment: all-round light) positive lead supply.
 BLACK: Negative lead supply. (CAUTION: Negative lead connected to case. To avoid energizing case, observe polarity).

Electrical connections are to be made such that only the forward compartment (masthead light) is energized with the other running lights (sidelights, stern lights etc.) while underway. Both compartments are energized simultaneously by themselves to create the all-round (anchor) light. Be sure to use double-pole switches; other-wise feedback will cause all lights in the system to be energized at the wrong time. SEE WIRING DIAGRAM.

- 6). Mount the base in accordance with both the template and instruction #7 below.
- 7). Make the top of the light is vertical during operation (see illustration) and the arrow on the top cover points ahead (not astern), with the reference mark parallel to the fore-aft centerline of the boat.
- 8). Relamp only with PERKO Cat. No. 0071DP0CLR bulbs (12V, 10W) or PERKO Cat. No. 0072DP1CLR bulbs (24V, 10W) to remain in compliance.

*The above referenced standards can be obtained from:

- (1). American Boat & Yacht Council, Inc.
 3069 Solomans Island Road
 Edgewater, Maryland 21037
- (2). U.S. Coast Guard
 Washington D.C. 20593
 (or your local C.G. office)

MOUNTING TEMPLATE

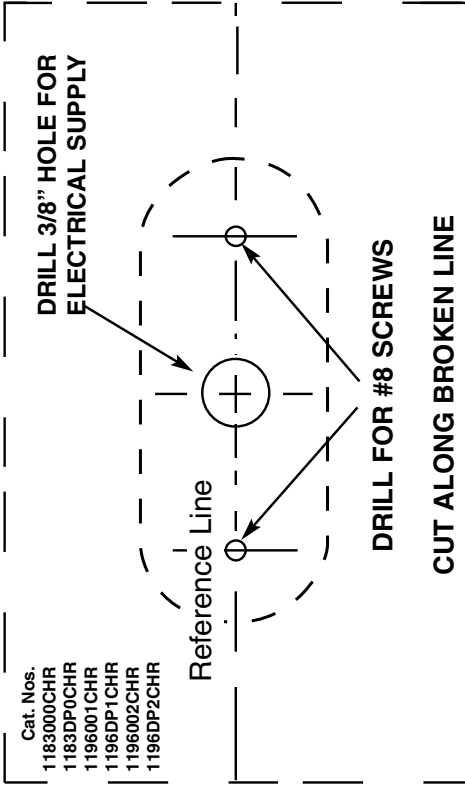

- Double-pole, double throw switch (center off)
- One position illuminates running lights (masthead, side & stern)
- Other position illuminates anchor light (forward & aft compartments or combination masthead/anchor light)

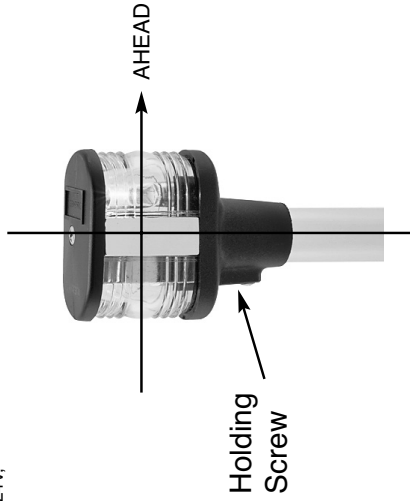

NOTE: TOP OF LIGHT MUST BE VERTICAL DURING OPERATION

PERKO, INC.
 16490 N.W. 13th Avenue
 Miami, FL 33169-5707
www.perko.com

2/04
 1183INS1

The background of the entire page is a light gray topographic map with white contour lines. The lines are irregular and wavy, representing elevation changes across a landscape. The map is centered and covers the entire area.

SEAVIEW///
ELEVATE YOUR ELECTRONICS

SEAVIEW///

Tel: 800-655-7922
www.seaviewglobal.com

EUROPEAN OFFICE

Tel: +33 4 94 53 27 70
www.seaviewprogress.com

1-121718