

SEAVIEW

ELEVATE YOUR ELECTRONICS

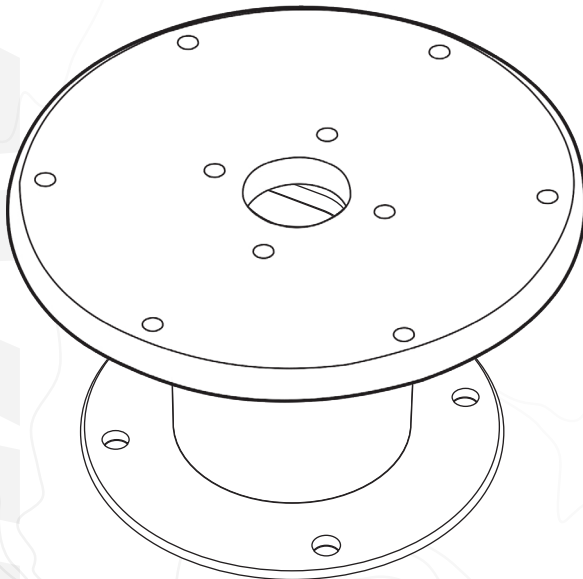

INSTALLATION INSTRUCTIONS

For Seaview Camera Mount:

PM5FM38

Refer to website for most up to
date instructions and videos.

WWW.SEAVIEWGLOBAL.COM

PARTS INCLUDED

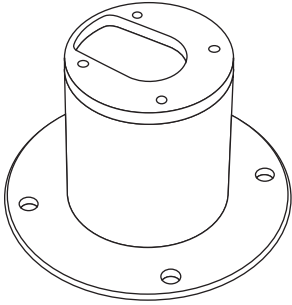

x1

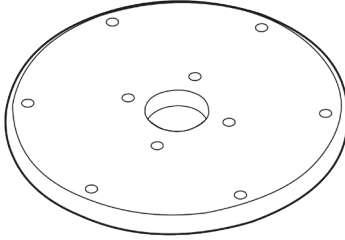

x1

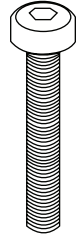

M6 x 45mm

x6

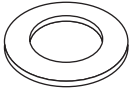

x6



x4 s.s.

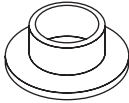

x4



x4



x6



1/4-20 x 1 1/2"

x4

TOOLS NEEDED

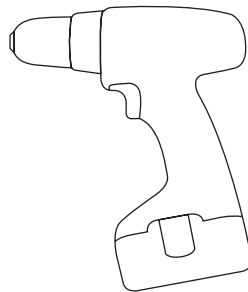
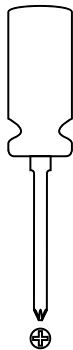
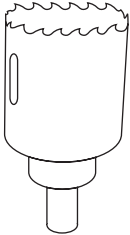

1 Mark the four holes for the base.

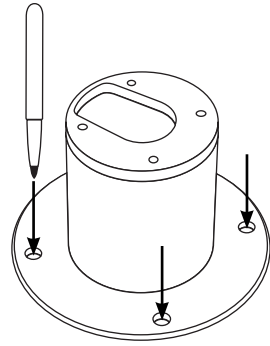

2 Drill the four holes for the base.

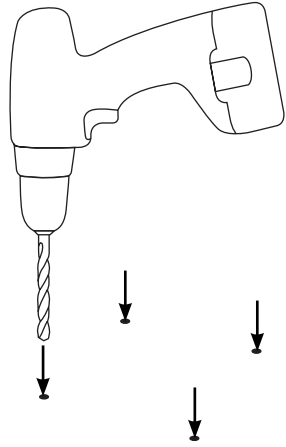

3 Using a hole saw, cut a hole for the electronics cable.

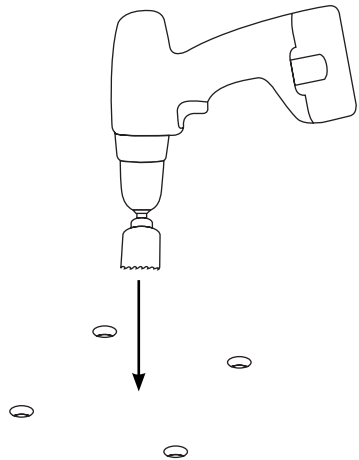

4 Route the electronics cable through the FLIR top down riser and place the camera on top of the riser.

Secure the FLIR M300 to the riser with the supplied hardware. Refer to FLIR instructions on how to bolt them together.

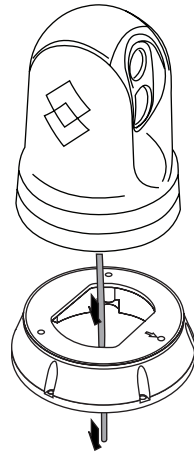

5 Place the top mounting plate onto the PM5FM38. Be sure that the four mounting holes are lined up.

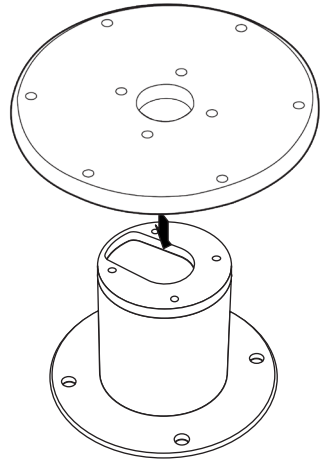

6 Secure the mounting plate to the mount using four nylon washers and bolts using an allen wrench.

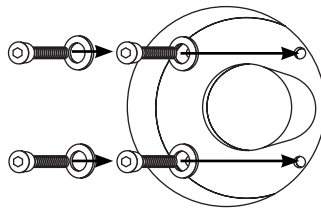
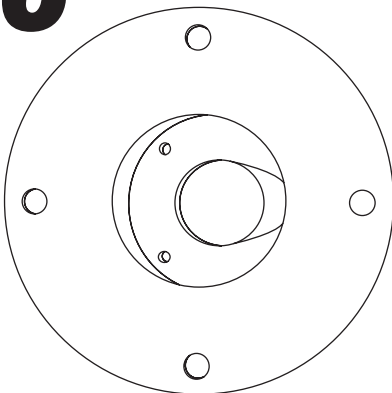

7 Place a S.S. washers over each 1/4-20 bolt followed by the nuts to secure.

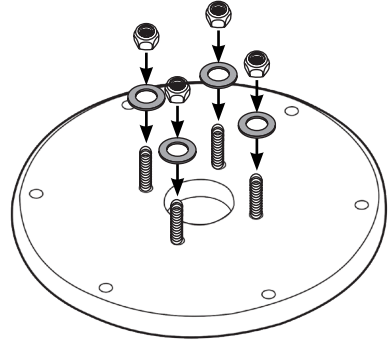

8 Place the camera on top of the mounting plate, making sure to line up the six mounting holes.

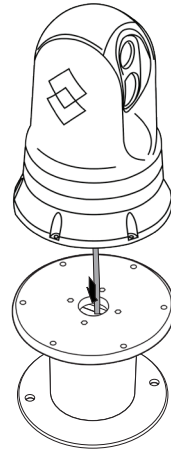

9 Screw the adapter plate to the PM5FM38 using the six M6 x 45mm bolts with an allen wrench

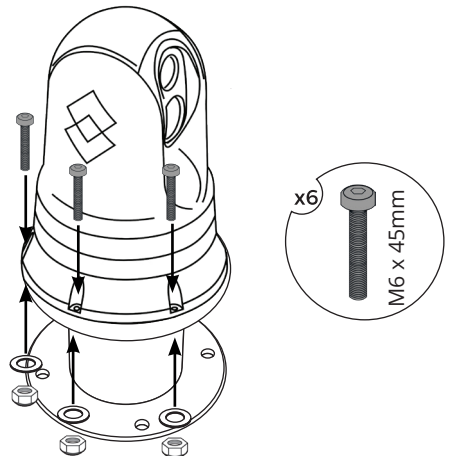

10

Apply marine adhesive sealant around the bottom of the mount. Be sure to go around the bolt holes.

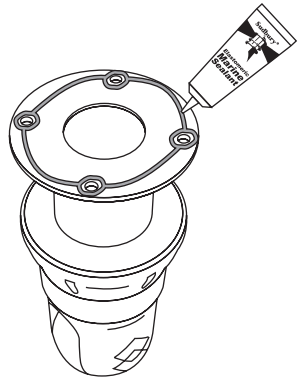

11

Place the mount onto the mounting surface.

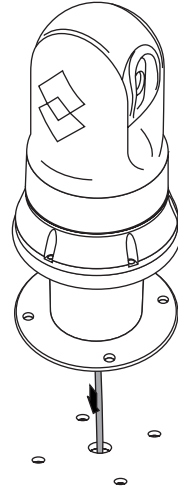

12

Insert the four nylon washers into the base bolt holes. Apply marine adhesive sealant around the nylon washers.

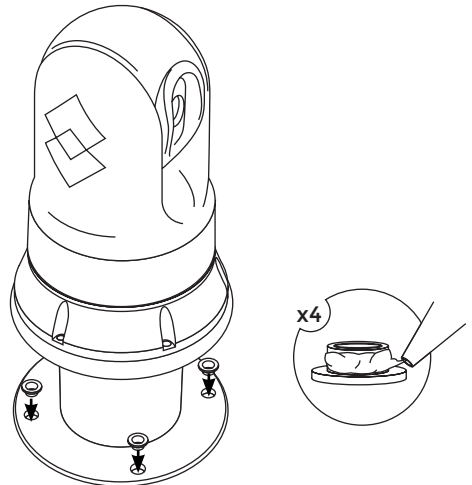

A background of a topographic map with contour lines, rendered in a light gray color. The map shows various landmasses and water bodies, with the lines indicating elevation or depth.

SEAVIEW///
ELEVATE YOUR ELECTRONICS

SEAVIEW///

Tel: 800-655-7922
www.seaviewglobal.com

EUROPEAN OFFICE

Tel: +33 4 94 53 27 70
www.seaviewprogress.com

5-071 820