

MIRROR BRACKET INSTALLATION

- BEFORE PERMANENTLY INSTALLING THE MIRROR BRACKET ①, PLACE THE ASSEMBLY ONTO THE RAILING OF THE PONTOON IN A DESIRABLE POSITION AS SHOWN.
- BE SURE THAT THE MIRROR BRACKET WILL PIVOT DOWN IN EITHER THE FORWARD OR BACKWARD POSITIONS (DEPENDING ON PONTOON BOAT) WITHOUT CONTACTING THE CONSOL OR THE BIMINI SUPPORT BRACKETS.
- ONCE THE DESIRED POSITION IS IDENTIFIED, REMOVE THE MIRROR BRACKET ASSEMBLY FROM THE PONTOON BOAT.
- TO PERMANENTLY LOCK THE MIRROR MOUNT IN PLACE APPLY A SMALL BEAD OF THE THREAD LOCKER ③ TO THE THREADS OF BOTH THE 1/2" SET SCREWS ②.
- REMOVE THE FILM FROM THE ADHESIVE BACKING ON THE FOAM STRIP ON THE INSIDE OF THE CLAMP AREA.
- CAREFULLY REPOSITION THE MIRROR BRACKET ONTO THE PONTOON RAILING IN ITS PREDETERMINED POSITION.
- TIGHTEN THE 1/2" SET SCREWS ② TO 40 IN-LBS (3.3 FT-LBS) OF TORQUE.
- INSTALL VR-100 MIRROR ④ BY SLIDING THE SCOOP PLATE ⑦ OVER THE THREADED STUD AND INSERTING THEM THROUGH THE MIRROR BRACKET ①.
- THEN INSTALL THE WASHER ⑤ AND KNOB ⑥.

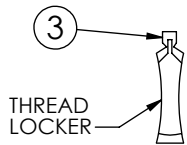
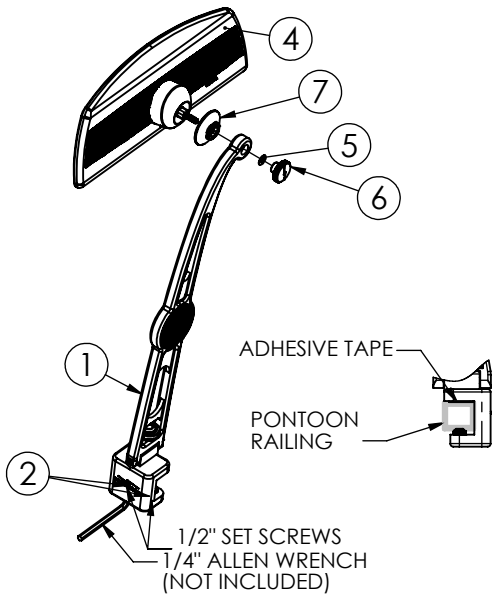

PXR-100-PRO Series - Instructions

CONTENTS OF BOX:

ITEM NO.	DESCRIPTION	QTY.
1	MIRROR BRACKET ASSEMBLY	1
2	1/2-13 X 3/4" CUP POINT SET SCREW	2
3	THREADLOCKER	1
4	VR-100 PRO PLASTIC MIRROR	1
5	WASHER, DELRIN	1
6	KNOB	1



1010 Larson Drive, Oak Ridge, TN 37830
(865) 425-0600 www.ptmedge.com

MIRROR BRACKET INSTALLATION

- BEFORE PERMANENTLY INSTALLING THE MIRROR BRACKET ①, PLACE THE ASSEMBLY ONTO THE RAILING OF THE PONTOON IN A DESIRABLE POSITION AS SHOWN.
- BE SURE THAT THE MIRROR BRACKET WILL PIVOT DOWN IN EITHER THE FORWARD OR BACKWARD POSITIONS (DEPENDING ON PONTOON BOAT) WITHOUT CONTACTING THE CONSOL OR THE BIMINI SUPPORT BRACKETS.
- ONCE THE DESIRED POSITION IS IDENTIFIED, REMOVE THE MIRROR BRACKET ASSEMBLY FROM THE PONTOON BOAT.
- TO PERMANENTLY LOCK THE MIRROR MOUNT IN PLACE APPLY A SMALL BEAD OF THE THREAD LOCKER ③ TO THE THREADS OF BOTH THE 1/2" SET SCREWS ②.
- REMOVE THE FILM FROM THE ADHESIVE BACKING ON THE FOAM STRIP ON THE INSIDE OF THE CLAMP AREA.
- CAREFULLY REPOSITION THE MIRROR BRACKET ONTO THE PONTOON RAILING IN ITS PREDETERMINED POSITION.
- TIGHTEN THE 1/2" SET SCREWS ② TO 40 IN-LBS (3.3 FT-LBS) OF TORQUE.
- INSTALL VR-100 MIRROR ④ BY SLIDING THE SCOOP PLATE ⑦ OVER THE THREADED STUD AND INSERTING THEM THROUGH THE MIRROR BRACKET ①.
- THEN INSTALL THE WASHER ⑤ AND KNOB ⑥.

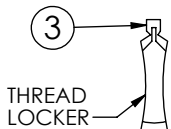
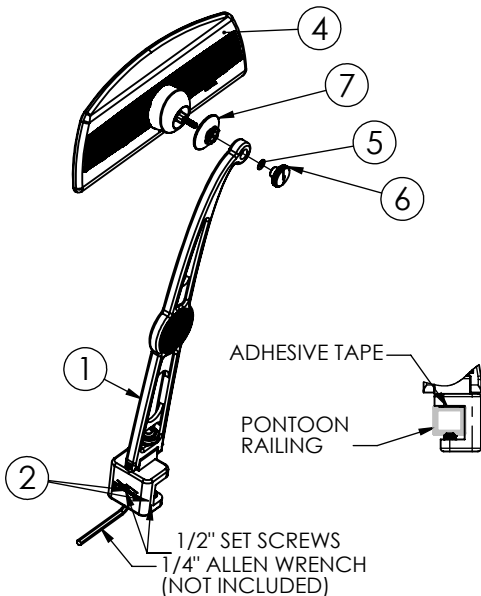

PXR-100-PRO Series - Instructions

CONTENTS OF BOX:

ITEM NO.	DESCRIPTION	QTY.
1	MIRROR BRACKET ASSEMBLY	1
2	1/2-13 X 3/4" CUP POINT SET SCREW	2
3	THREADLOCKER	1
4	VR-100 PRO PLASTIC MIRROR	1
5	WASHER, DELRIN	1
6	KNOB	1
7	SCOOP PLATE, PSC	1



1010 Larson Drive, Oak Ridge, TN 37830
(865) 425-0600 www.ptmedge.com



Cleaning Instructions for MIRROR LENS, ALUMINUM HOUSING, and ALUMINUM BRACKET

IMPORTANT - There are certain precautions necessary when cleaning anodized aluminum. DO NOT Use Window Cleaners containing AMMONIA

Aggressive alkaline or acid cleaners must never be used. Cleaning hot, sun-heated surfaces is not recommended as this may accelerate a chemical reaction with the surface. Excessive rubbing should not be necessary.

Mild soaps (defined by ph range of 5.0 – 8.0), i.e., Cascade, Ivory Liquid, Ivory Snow, Joy are recommended for cleaning aluminum surfaces. However, it is important to adequately rinse all surfaces after cleaning. Other cleaning solutions that may be used include...

- Aluminum Cleaner HC-22 (Klenzade Products)
- Clepo 83-M – (Frederick Gumm)
- Fels Soap Granules (Fels & Company)
- Fleetline JC-5 (Oakite Products)

IMPORTANT – When cleaning the VR Series mirror lens, please make sure excess cleaning solution is not left to dry on the aluminum housing or bracket components. PITTING WILL OCCUR.

PTM Edge is a division of Protomet Corporation. Protomet has a 14 year history of manufacturing products for the Military, Aerospace, Automotive, Scientific, and Marine Industries. Products are diverse as to include components supplied for Mercedes as well as the U.S. Military.



PTMEdge/Protomet Corp 1010 Larson Dr. Oak Ridge, TN 37830 865.425.0600 www.ptmedge.com



Cleaning Instructions for MIRROR LENS, ALUMINUM HOUSING, and ALUMINUM BRACKET

IMPORTANT - There are certain precautions necessary when cleaning anodized aluminum. DO NOT Use Window Cleaners containing AMMONIA

Aggressive alkaline or acid cleaners must never be used. Cleaning hot, sun-heated surfaces is not recommended as this may accelerate a chemical reaction with the surface. Excessive rubbing should not be necessary.

Mild soaps (defined by ph range of 5.0 – 8.0), i.e., Cascade, Ivory Liquid, Ivory Snow, Joy are recommended for cleaning aluminum surfaces. However, it is important to adequately rinse all surfaces after cleaning. Other cleaning solutions that may be used include...

- Aluminum Cleaner HC-22 (Klenzade Products)
- Clepo 83-M – (Frederick Gumm)
- Fels Soap Granules (Fels & Company)
- Fleetline JC-5 (Oakite Products)

IMPORTANT – When cleaning the VR Series mirror lens, please make sure excess cleaning solution is not left to dry on the aluminum housing or bracket components. PITTING WILL OCCUR.

PTM Edge is a division of Protomet Corporation. Protomet has a 14 year history of manufacturing products for the Military, Aerospace, Automotive, Scientific, and Marine Industries. Products are diverse as to include components supplied for Mercedes as well as the U.S. Military.



PTMEdge/Protomet Corp 1010 Larson Dr. Oak Ridge, TN 37830 865.425.0600 www.ptmedge.com