

SEAVIEW

ELEVATE YOUR ELECTRONICS

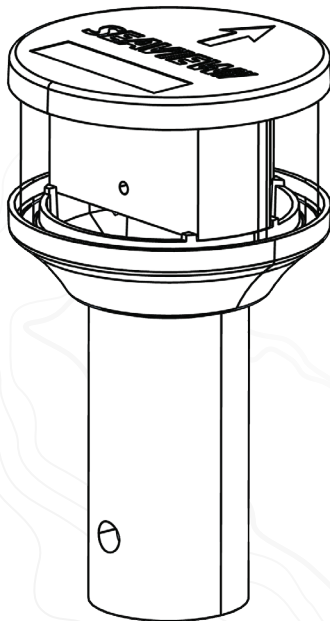

INSTALLATION INSTRUCTIONS

For Seaview Lights:

LTBLED12

Refer to website for most up to
date instructions and videos.

WWW.SEAVIEWGLOBAL.COM

PARTS INCLUDED

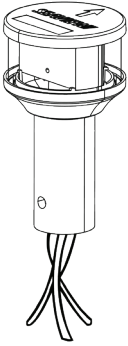

x1
(LTBLED12)

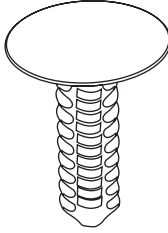

x2
(LTBRVT)

TOOLS NEEDED



Sudbury Elastomeric Marine Sealant is recommended. To purchase call 800-655-7922 or visit www.seaviewglobal.com

1

Apply marine adhesive sealant around the shaft of the LTBLED12 and then slide into the top end of the lightbar.

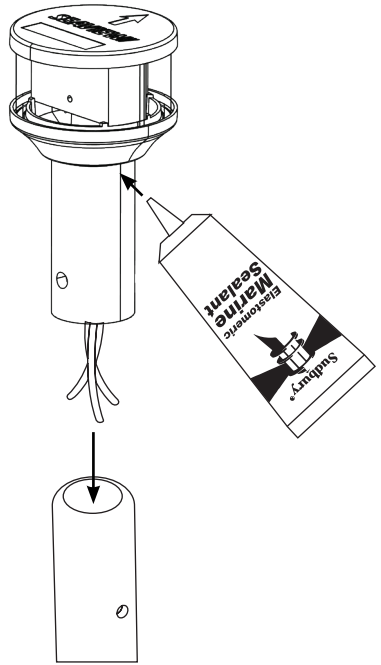

2

Be sure that the light is facing the correct direction. The arrow on top of the Seaview light should be facing forward (FWD).

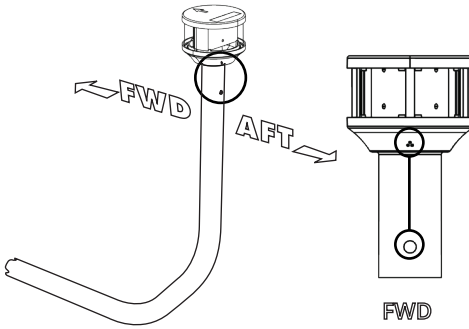

3

Insert the two push pins into the light bar and light to secure.

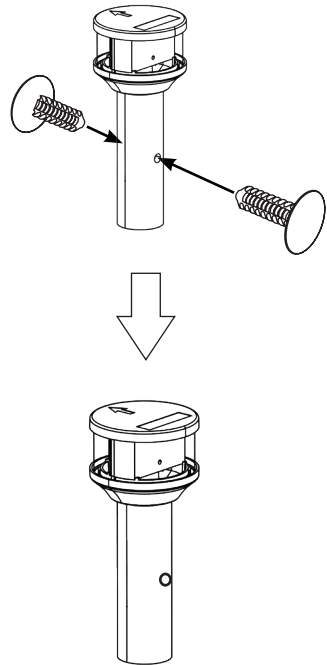

OPTIONAL ACCESSORIES

Call 800-655-7922 or visit www.seaviewglobal.com for available accessories.

LIGHT BARS

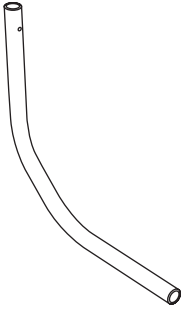

LTBR

Fits closed dome radars.

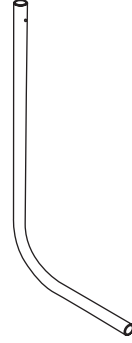

LTBS

Fits 20" or smaller satdomes.

SPREADER KIT

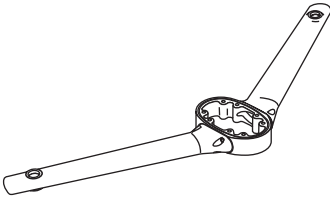

SP1MOD

Allows user to mount GPS units or antennas onto a Seaview Modular Mount.

WEDGES

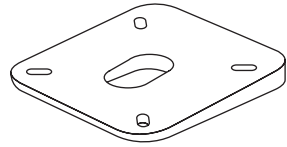

Compensates for plane angle.
Available in 2, 4 or 6 degree wedges.

HINGES

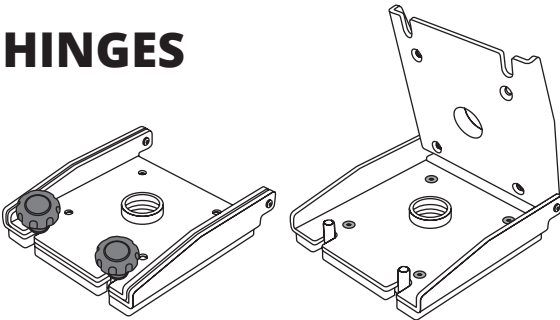

Hinge back your Seaview Modular Mount with a Seaview Hinge for added height clearance.

LTBLED12 LED Combination Masthead and All-Round White (Anchor) Light

The above light is designed for use on sail or power driven vessels under 20 meters (65.6 ft.) in length operating on a nominal 12 volt system. In order to comply with '72 COLREGS and U.S. Inland Rules, the following must be adhered to:

MOUNTING INFORMATION

Read all instructions before proceeding.

- 1) These instructions show the orientation of each light. For proper light selection, positioning and configuration, refer to A.B.Y.C. Standard A-16*, the '72 COLREGS and the U.S. Inland Navigation Rules*. These lights are supplied complete with 12 volt LED's. LED lights have no user serviceable parts.
- 2) These lights are designed to be mounted on a horizontal surface.
- 3) These lights are furnished for mounting such that the long dimension of the mounting base is parallel to the fore-aft centerline of the boat.
- 4) This light is furnished with a 3/4 inch tube and is designed to be mounted vertically into a 3/4 inch hole.
- 5) WIRING: Please choose from the configurations that meet your current wiring.

Attach supply connections to the light making sure to wire in accordance with both A.B.Y.C. Standard E4* and U.S. Coast Guard Safety Standards for Boat Electrical Systems (33 CFR 183)*.

The connection wires are coded as follows:

WHITE: Steaming: Forward compartment only (masthead light) positive lead supply.
 RED: Anchor: Forward compartment and aft compartment (anchor light) positive lead supply.
 BLACK: Ground: Negative lead supply.

Electrical connections are to be made such that only the forward compartment (masthead light) is energized with the other running lights (sidelights, stern lights etc.) while underway. Both compartments are energized simultaneously by themselves to create the all-round (anchor) light.

- 6) Make sure the top of the light is vertical during operation (see illustration) and the arrow on the top cover points ahead (not astern), with the reference mark parallel to the fore-aft centerline of the boat.

*The above referenced standards can be obtained from:

- (1). American Boat & Yacht Council, Inc.
613 Third Street, Suite 10
Annapolis, MD 21403
- (2). U.S. Coast Guard
Washington D.C. 20593
(or your local C.G. office)

WIRING DIAGRAMS

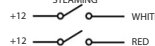

Diagram A
(Rotary Switch)



White	Red	Light Status
0	0	OFF
+12	0	Steaming
0	+12	Anchor

Diagram B
(Two Switches)



White	Red	Light Status
0	0	OFF
+12	0	Steaming
0	+12	Anchor
+12	+12	Anchor

Diagram C
(SPDT Toggle Switch)

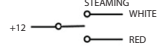

White	Red	Light Status
+12	0	Steaming
0	0	OFF
0	+12	Anchor

CONFIRM LIGHT MOUNTING

Arrow should be pointing forward (Ahead)



APPROPRIATE WIRE INSTALLATION

Using Waterproof Butt Connectors (not included)

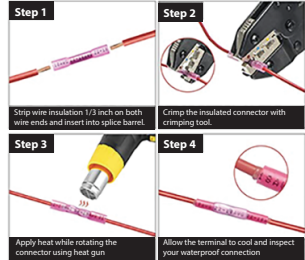

Prop. 65 Warning for California Residents
 WARNING: This product may contain chemicals known to the State of California to cause cancer, birth defects, or other reproductive harm.

A background of a topographic map with contour lines, rendered in a light gray color. The map shows various landmasses and water bodies, with the lines indicating elevation or depth.

SEAVIEW///
ELEVATE YOUR ELECTRONICS

SEAVIEW///

Tel: 800-655-7922
www.seaviewglobal.com

EUROPEAN OFFICE

Tel: +33 4 94 53 27 70
www.seaviewprogress.com

1-04212022