

Controller Locator Tool Manual

Seakeeper Ride | Controller Locator Tool Manual

1. Introduction

Updated 5/11/2023



ATTENTION: The Seakeeper Ride Controller Locator Tool and instructions are for certified dealers and OEM boat installers.

This document is intended to give details and guidance for assembling and using the Seakeeper Ride Controller Locator Tool.

Due to the quantity of parts and careful installation requirements, set aside a clean workspace, take inventory of necessary tools and parts, and review the entirety of this manual before setting to work.

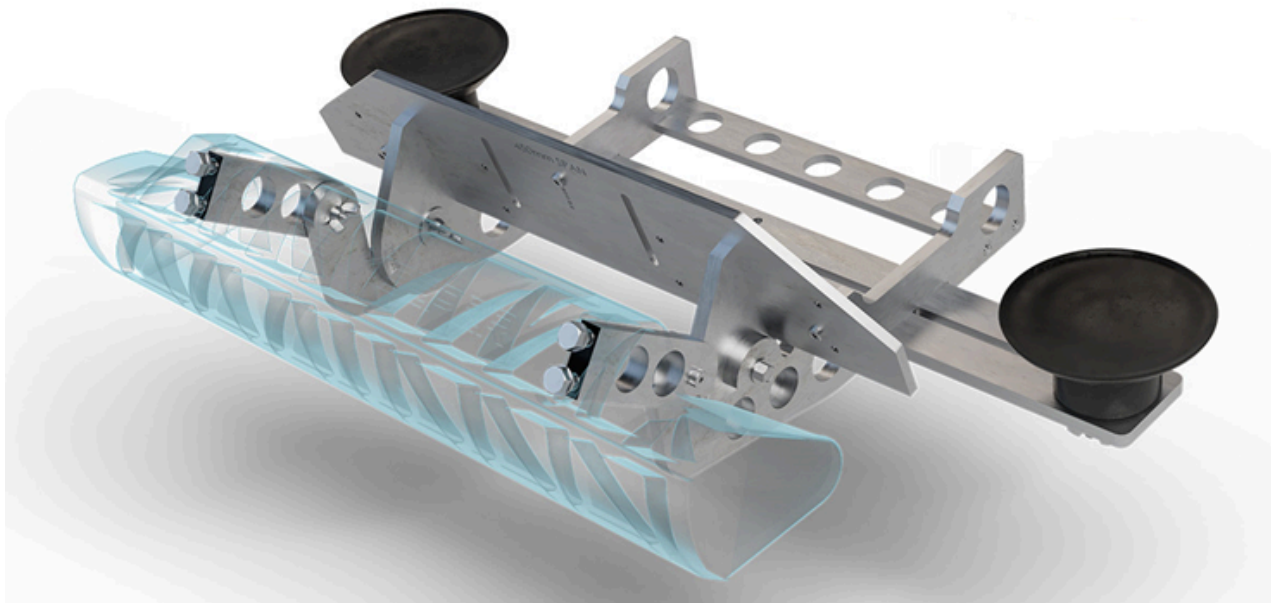

Figure 1- Seakeeper Ride Controller Locator Tool

2. Controller Locator Tool Kit

The Seakeeper Ride Controller Locator Tool comes with all pieces and parts, but some assembly will be required before the tool can be used.

The Controller Locator Tool works for the installation of the Seakeeper Ride models: 450, 525, and 600 mm.

Three Blades are provided in the kit depending on the planned span for the vessel. Three Transom Plate assemblies are also provided with the kit depending on the planned span on the vessel.

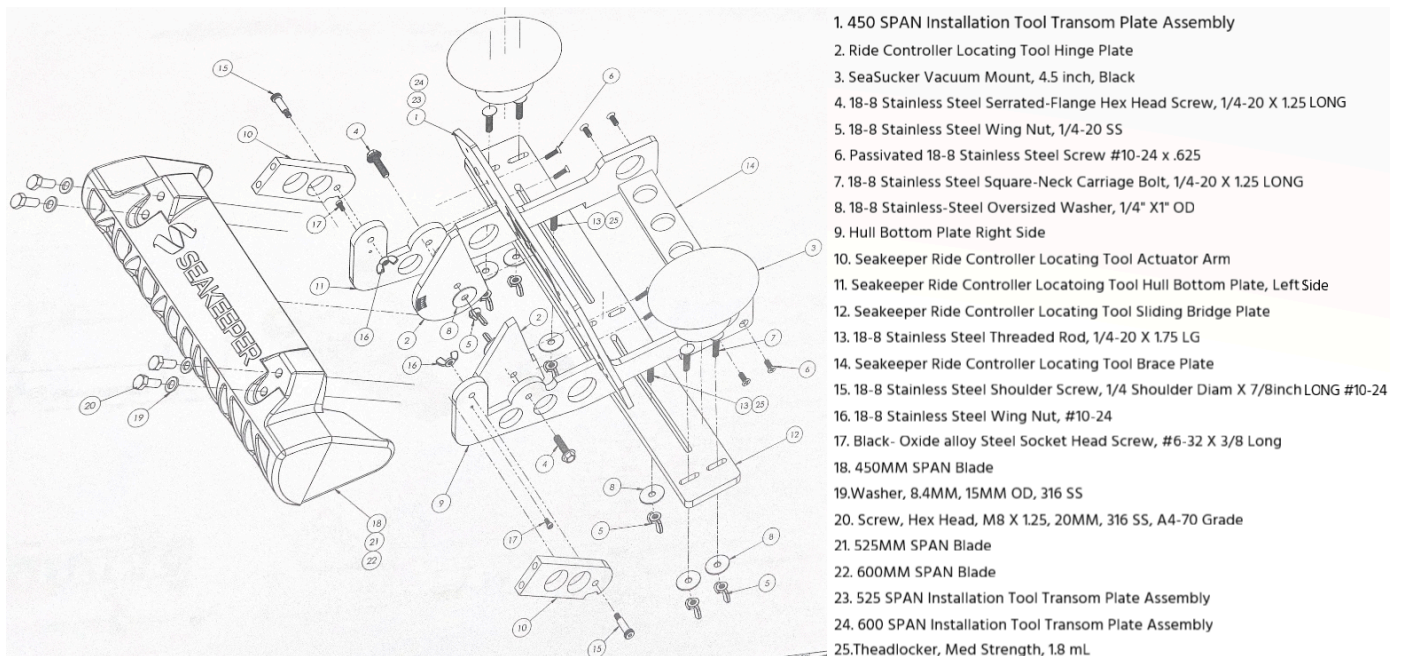

Figure 2- Kit provided pieces.

3. Controller Locator Assembly

Assembly Steps:

1. Review parts and make sure all parts are included and accounted for.
2. Assemble the Locating Tool Hull Bottom Plate, right side (#9) to the Locating Tool Brace Plate (#14) by using 18-8 Stainless Steel phillips flat head screw, #10-24 x .625 (#6).
3. Repeat previous step using the Locating Tool Hull Bottom Plate, left side (#11).
4. Install the Locating Tool Hinge Plate (#2) to the Locating Tool Hull Bottom Plate (#9 & #11).
Note: The Hinge Plate is interchangeable.
5. Put the Locating Tool Actuator Arm (#10) to the end of the Locating Tool Hull Bottom Plate (#9 & #11). **Note:** The Black-oxide Alloy Steel Socket head screw, #6-32 x 3/8 long (#17) may be installed already. If it is not installed already, install first.
6. Installation of the Transom Plate Assembly (#1) will be based on the size of the system the customer needs.
7. Locating Tool Sliding Bridge Plate (#12) will be installed on the Bottom of the Two Studs from the Locating Tool Hull Bottom Plate.
8. Assembly of the Sea Suckers will require the removal of the four phillips head screws on the Bottom of the Sea Sucker to install two 18-8 Stainless Steel Square-neck Carriage Bolts, 1/4-20 x 1.25 long.
9. **Tech Tip:** Use the two Fender Washers and Wing nuts to hold the bolts in place and glue the Stainless Steel Square-neck Carriage bolt in place please allow to dry. Then assemble the Sea Sucker back together.
10. The Sea Suckers can be placed anywhere on the Locating Tool Sliding Bridge Plate as need be to adhere to the Bottom of the boat to accommodate for strakes and chines in the hull of the boat.

Note: Sea Suckers will not adhere to a Hull that has bottom paint.

Note: Tool can be used without the Sea Sucker by holding tight to the Hull by hand.

Note: Locating Tool will need approximately 8-10 inches in depth on the bottom of the Hull for clearance. If the boat is on a trailer, the bunks of the trailer may interfere with tool placement. If possible, slide the boat back on the trailer to accommodate.



ATTENTION: DO NOT TRAILER BOAT WITH IT IN THIS POSITION.

4. How to use the Controller Locator Tool

Once the Locating Tool is assembled, and the correct size Blade is installed, it can now be used to determine if the Seakeeper Ride system will work on the boat and have the correct clearances.

1. Place the assembled Locator Tool on the transom to align the transom plate, as per mechanical installation, to the outside edge of hull.
2. Check alignment of Sea Suckers to make sure that there are no Strakes or Chines preventing the Sea Suckers from adhering to the Hull of the boat.
3. If adjustment is needed, the Locating Tool Slide Bridge can be loosened and will slide from left to right.
4. The Sea Suckers can be placed on the Slide Bar as needed if that adjustment is not enough,
5. If more adjustments are needed, the Transom Plate assembly has three positioning holes to move just the Transom Plate from right to left.

Note: For position of the tool, you do not need to have the Blade and the Actuator Arms installed to help reduce weight. The Arms and the Blade can be installed after the tool is adhered to the Hull of the boat.

- With tool placed in the correct position, you now can trace the Hull for grinding and drill the three positioning screws indicated by the brass bushings.
- To place tool on the opposite side of the hull, all settings will have to be reversed.

6. When the Locating tool is on the Hull location needed, check the Transom angle that is located on both sides of the Hinge Plate (Check mechanical installation for transom angle wedge pack assembly.) The angle the Hinge Plate shows will have a matching angle marker on the 450, 525, or 600 Plates in the Controller Locator Tool kit. The number that the Hinge Plate is lined up with will be the height you drill through the example size Actuator Plate for where the Cable Gland hole will need to be drilled. The hole drilled will reflect the top of the key.

Tip: Instead of removing the Sea Suckers and resetting, remove the slide bar with the two wing nuts and rotate slide bar 180 degrees.

- Remember to check both sides for Transom angle. Transoms can vary from Port to Starboard as much as 4 degrees.

- Sea Suckers will not adhere to the Hull on boats with bottom paint. If this happens remove the Sea Suckers and hold the tool in position by hand.

5. Drawings

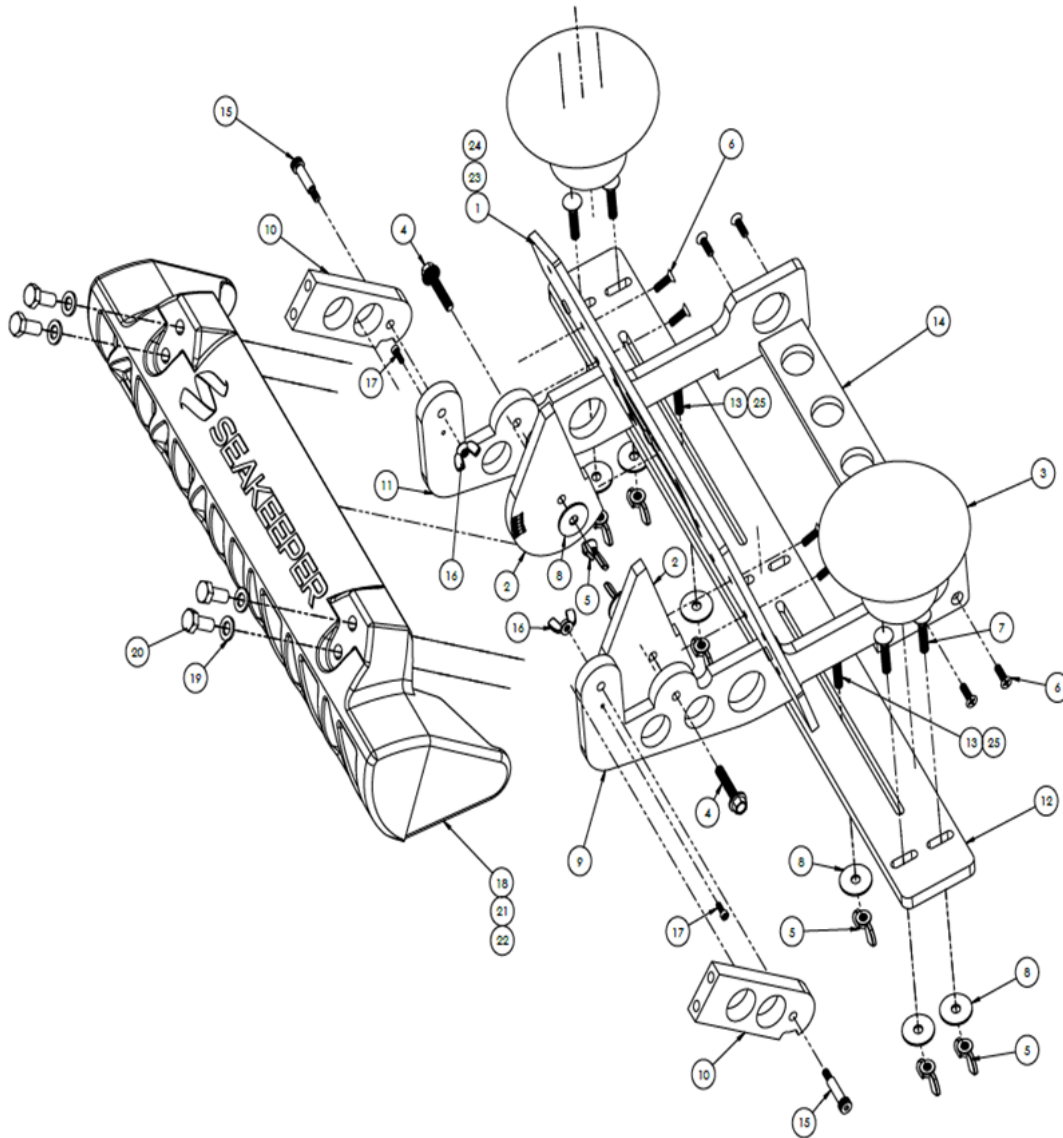

PROPRIETARY AND CONFIDENTIAL THE INFORMATION CONTAINED IN THIS DRAWING IS THE SOLE PROPERTY OF SEAKEEPER INCORPORATED. ANY REPRODUCTION IN PART OR AS A WHOLE WITHOUT THE WRITTEN PERMISSION OF SEAKEEPER IS PROHIBITED. THIS DRAWING SUPERSEDES ALL OTHER FILE FORMAT TYPES UNLESS OTHERWISE SPECIFIED. DO NOT SCALE DRAWING	THE ANGLE PROJECTION 	SEAKEEPER <small>Seakeeper Inc. 40511 Hillwood Lane, Suite 100 Columbia, MD 21047</small> RIDE CONTROLLER LOCATING TOOL ASSEMBLY
	WEIGHT - LBS: --- MATERIAL: ---	

NOTES:

- 1) TOOL IS USED TO LOCATE TRANSOM PLATE POSITIONING SCREWS FOR RIDE CONTROLLER INSTALLATION FOR 450, 525, OR 600 MM SPAN CONTROLLERS. TOOL CAN ALSO BE USED TO CONFIRM CLEARANCES FOR MOUNTING LOCATION ON THE VESSEL'S TRANSOM.
- 2) THREE BLADES ARE PROVIDED IN THE KIT DEPENDING ON THE PLANNED SPAN FOR THE VESSEL.
- 3) THREE TRANSOM PLATE ASSEMBLIES ARE PROVIDED WITH THE KIT DEPENDING ON THE PLANNED SPAN ON THE VESSEL.

REVISIONS			
REV.	DATE	DESCRIPTION	APPROVED
1		INITIAL RELEASE	BHS

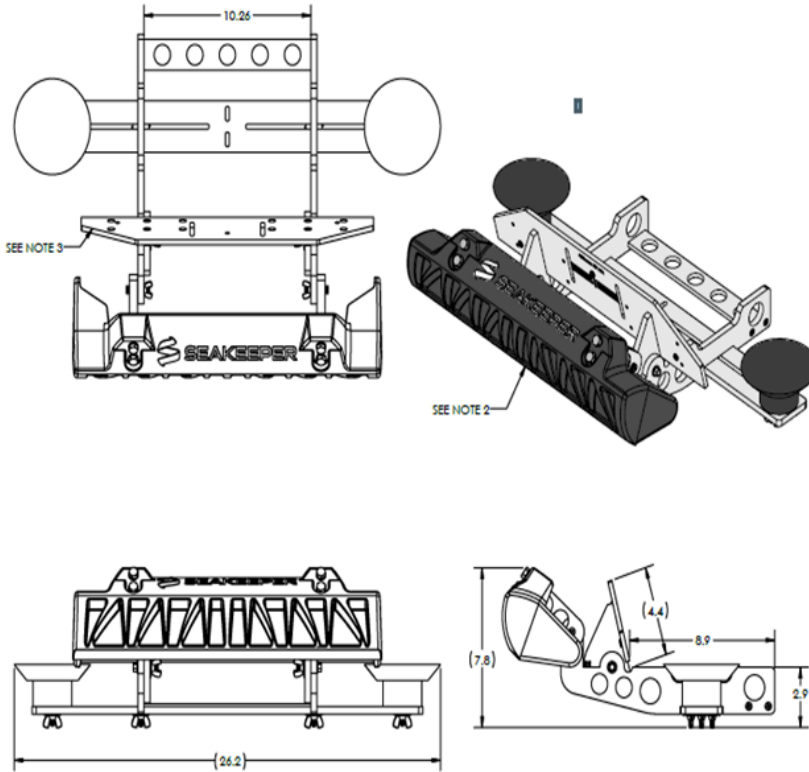

25	70101	THREADLOCKER, MED STRENGTH, 1.8 ML	1
24	13258	600 SPAN INSTALLATION TOOL TRANSOM PLATE ASSEMBLY	1
23	13257	525 SPAN INSTALLATION TOOL TRANSOM PLATE ASSEMBLY	1
22	12805	600MM SPAN BLADE	1
21	12752	525MM SPAN BLADE	1
20	60871	SCREW, HEX HEAD, M8 X 1.25, 20MM, 316 SS, A4-70 GRADE	4
19	60858	WASHER, 8.4MM, 15 MM OD, 316 SS	4
18	12476	450MM SPAN BLADE	1
17	60983	Black-Oxide Alloy Steel Socket Head Screw, #6-32 X 3/8 LONG	2
16	60975	18-8 Stainless Steel Wing Nut, #10-24	2
15	60974	18-8 Stainless Steel Shoulder Screw, 1/4 SHOULDER DIAM X 7/8 INCH LONG, #10-24	2
14	13214	RIDE CONTROLLER LOCATING TOOL BRACE PLATE	1
13	60982	18-8 Stainless Steel Threaded Rod, 1/4-20 X 1.75 LG	2
12	13213	RIDE CONTROLLER LOCATING TOOL SLIDING BRIDGE PLATE	1
11	13211	RIDE CONTROLLER LOCATING TOOL HULL BOTTOM PLATE, LEFT SIDE	1
10	13215	RIDE CONTROLLER LOCATING TOOL ACTUATOR ARM	2
9	13212	RIDE CONTROLLER LOCATING TOOL HULL BOTTOM PLATE, RIGHT SIDE	1
8	60981	18-8 Stainless Steel Oversized Washer, 1/4" X 1" OD	8
7	60980	18-8 Stainless Steel Square-Neck Carriage Bolt, 1/4-20 X 1.25 LONG	4
6	60978	Passivated 18-8 Stainless Steel Phillips Flat Head Screw, #10-24 X .625	8
5	60979	18-8 Stainless Steel Wing Nut, 1/4-20 SS	8
4	60976	18-8 Stainless Steel Serrated-Flange Hex Head Screw, 1/4-20 X 1.25 LONG	2
3	41060	Seasucker Vacuum Mount, 4.5 Inch, Black	2
2	13119	RIDE CONTROLLER LOCATING TOOL HINGE PLATE	2
1	13256	450 SPAN INSTALLATION TOOL TRANSOM PLATE ASSEMBLY	1
ITEM NO.	PART NO.	DESCRIPTION	QTY.

<p>CONFIDENTIAL AND PROPRIETARY</p> <p>THE INFORMATION CONTAINED IN THIS DRAWING IS THE SOLE PROPERTY OF SEAKEEPER INCORPORATED. ANY REPRODUCTION IN PART OR AS A WHOLE WITHOUT THE WRITTEN PERMISSION OF SEAKEEPER IS PROHIBITED.</p> <p>THIS DRAWING IS PERMITTED FOR ALL OTHER FILE FORMAT TYPES UNLESS OTHERWISE SPECIFIED.</p> <p>DO NOT SCALE DRAWING</p>	<p>3RD ANGLE PROJECTION</p> <p>WEIGHT - LBS: ---</p> <p>MATERIAL: ---</p>	<p>SEAKEEPER</p> <p>13207</p> <p>RIDE CONTROLLER LOCATING TOOL ASSEMBLY</p>