



s130N

1.25m Maritime Satellite TV
Antenna System

Installation & Operation User Guide

Serial number of the product

This serial number will be required for all troubleshooting or service inquiries.

Intellian

© 2022 Intellian Technologies, Inc. All rights reserved. Intellian and the Intellian logo are trademarks of Intellian Technologies, Inc., registered in the U.S. and other countries. The s130N is a trademark of Intellian Technologies, Inc. Intellian may have patents, patent applications, trademarks, copyrights, or other intellectual property rights covering subject matter in this document. Except as expressly provided in any written license agreement from Intellian, the furnishing of this document does not give you any license to these patents, trademarks, copyrights, or other intellectual property. All other logos, trademarks, and registered trademarks are the property of their respective owners. Information in this document is subject to change without notice. Every effort has been made to ensure that the information in this manual is accurate. Intellian is not responsible for printing or clerical errors.

Disclaimer

The information in this user manual is subject to change without prior notice throughout the product life cycle. The printed version of the user manual is periodically updated, so this copy may contain inaccuracies or omissions compared to the most recent product information. The most up-to-date information is available on our website at www.intelliantech.com.

Table of Contents

Chapter 1. Precautions	7
1.1 Warnings, Cautions, and Notes	7
1.2 General Precautions	7
Chapter 2. Certifications	8
Chapter 3. Introduction	11
3.1 Introduction of s130N	11
3.2 Features of s130N	12
Chapter 4. Planning Installation	13
4.1 Selection of Installation Site	13
4.1.1 Minimize Satellite Blockage	13
4.1.2 Avoid RF Interference	14
4.2 System Package	15
4.2.1 Above Deck Unit (ADU)	15
4.2.2 Antenna Control Unit (ACU)	16
4.2.3 Multi Switch Module (MSM)	16
4.2.4 Packing List	17
4.3 System Cables (Customer Supplied)	18
4.3.1 RF Cables (Customer Supplied)	18
4.3.2 Gyrocompass Cable (Customer Furnished)	18
4.4 Unpacking System Package	19
Chapter 5. Installing Above Deck Unit (ADU)	21
5.1 Antenna Dimensions	21
5.2 Antenna Mounting Hole Pattern	23
5.3 Designing Mast (Example Only)	24
5.4 Routing RF Cable on Mast (Example Only)	26
5.5 Removing Antenna from Wooden Pallet	27
5.6 Moving Antenna Above Mast	29
5.7 Mounting Antenna on Mast	30
5.8 Connecting RF Cable to Antenna	32
Chapter 6. Installing Below Deck Unit	35
6.1 Selection of BDU Installation Site	35
6.2 ACU Dimensions	35
6.3 MSM Dimensions	36
6.4 Mounting ACU/MSM	37
6.5 System Configurations	38
6.5.1 Single Antenna System Configuration	38
6.5.2 Dual Antenna System Configuration (Optional)	39
6.6 BDU Cable Connection	40
6.6.1 ACU Back Panel Connectors	40
6.6.2 MSM Back Panel Connectors	40
6.6.3 ACU Connector Pinout Guide	41

6.6.4 MSM Connector Pinout Guide	44
6.6.5 Connecting Power to ACU	45
6.6.6 Connecting ACU to ADU	45
6.6.7 Connecting ACU to Ship's Gyrocompass	46
6.6.8 Connecting RF Cables (RF1-4) to the Multi-Switch Module	47
6.7 ACU to PC Communication Setup	49
6.7.1 TCP/IP Connection	49
6.7.2 USB Connection	50
6.7.3 Wi-Fi Connection	51
Chapter 7. Operating Install Wizard	52
7.1 Turning On System	52
7.2 Accessing AptusNTV	52
7.3 Starting Install Wizard	53
Chapter 8. Operating ACU	58
8.1 Introduction	58
8.1.1 ACU Front Panel View	58
8.1.2 ACU Display Menu	59
8.2 Startup	60
8.3 Satellite Information	61
8.4 Interface Information	63
8.5 Antenna Information	64
8.6 Diagnosis	65
8.7 USB Function	67
8.7.1 Log Download	68
8.7.2 Firmware Upload	69
8.7.3 Backup to USB	70
8.7.4 Restore From USB	71
Chapter 9. Using AptusNTV	72
9.1 Introduction	72
9.2 Accessing AptusNTV for ACU	72
9.3 Main Page (Page Login)	73
9.4 Top Menus	74
9.5 Account Menu	75
9.5.1 Account	76
9.5.2 User Management	77
9.5.3 System Information	78
9.5.4 Support	79
9.6 Dashboard	80
9.6.1 How to Add & Remove Panels (Dashboard Setting)	80
9.6.2 How to Use Shortcut Settings	82
9.7 Setup	83
9.7.1 Ship	83
9.7.2 Antenna Setting	85
9.7.3 Satellite Set	88
9.7.4 Network	89
9.7.5 Wi-Fi	90

9.7.6 Mediator (Optional)	91
9.8 System Tools	92
9.8.1 ACU Upgrade	92
9.8.2 Firmware Upgrade	94
9.8.3 Library	96
9.8.4 Satellite Preset	97
9.8.5 Backup & Restore	98
9.8.6 Reset	99
9.8.7 Logs	100
9.8.8 Diagnostic	101
9.9 Install Wizard	102
Chapter 10. Specification	103
10.1 Technical Specification	103
10.2 Environmental Specification	105
Chapter 11. Warranty	106
Chapter 12. Appendix	107
12.1 Appendix A. Tightening Torque Specification	107



List of Figures

Chapter 4. Planning Installation	13
Figure 1: Elevation Limit of Obstacles	13
Figure 2: Potential RF Interference	14
Figure 3: Radome and Pedestal	15
Figure 4: Front Panel of ACU	16
Figure 5: Back Panel of ACU	16
Figure 6: Front Panel of MSM	16
Figure 7: Back Panel of MSM	16
Chapter 5. Installing Above Deck Unit (ADU)	21
Figure 8: Antenna Side View	21
Figure 9: Antenna Bottom View (Outside/Inside)	22
Figure 10: Antenna Mounting Hole Template	23
Figure 11: Recommended Size of Mast	25
Figure 12: Routing Cable Through Outside of Mast	26
Figure 13: Installing Bolts for Antenna-Mast Assembly	30
Figure 14: Installing Sequence of Bolts	30
Figure 15: Cable Connection Inside Radome	34
Figure 16: Cable Connections on Power Switch Unit	34
Chapter 6. Installing Below Deck Unit	35
Figure 17: ACU Dimensions	35
Figure 18: MSM Dimensions	36
Figure 19: 19" Rack Mount ACU (MSM)	37
Figure 20: Single Antenna System Configuration (Basic Antenna System)	38
Figure 21: Dual Antenna System with Multi-Switch Connection Configuration	39
Figure 22: ACU Back Panel Connectors	40
Figure 23: MSM Back Panel Connectors	40
Figure 24: Connecting Power to ACU	45
Figure 25: ACU to Antenna Cable Connection	45
Figure 26: ACU to Ship's Gyrocompass Cable Connection	46
Figure 27: NMEA 0183 Gyrocompass Cable Connection	46
Figure 28: Multi-Switch Module Connection	47
Figure 29: Front Panel Management LAN Port Connection	49
Figure 30: Front Panel USB Port Connection	50
Figure 31: Rear Panel Wi-Fi Dongle Connection	51
Chapter 7. Operating Install Wizard	52
Figure 32: Front Panel Management LAN Port Connection	52
Chapter 8. Operating ACU	58
Figure 33: ACU Front Panel View	58

Chapter 1. Precautions





1.1 Warnings, Cautions, and Notes

WARNING, CAUTION, and NOTE statements are used throughout this manual to emphasize important and critical information. You must read these statements to help ensure safety and to prevent product damage. The statements are defined below.

	<p>WARNING</p> <p>WARNING indicates a potentially hazardous situation that, if not avoided, could result in death or serious injury.</p>
	<p>CAUTION</p> <p>CAUTION indicates a potentially hazardous situation that, if not avoided, could result in minor or moderate injury. It may also be used to alert users about unsafe practices.</p>
	<p>NOTE</p> <p>A NOTE statement is used to notify people of installation, operation, programming, or maintenance information that is important, but not hazard-related.</p>

1.2 General Precautions

Before you use the antenna, make sure that you have read and understood all safety requirements.

	<p>THIS WAY UP</p> <ul style="list-style-type: none"> Place the boxes/crates on the floor with the arrow pointing up.
	<p>FRAGILE</p> <ul style="list-style-type: none"> Since the Radome is fragile, handle it with care. Do not apply excessive pressure or shock. This can cause surface cracking or other damage.
	<p>DO NOT STACK</p> <ul style="list-style-type: none"> Do not stack boxes/crates as there is a risk boxes/crates may fall and be damaged.
	<p>KEEP DRY</p> <ul style="list-style-type: none"> Always make sure the antenna is stored on a dry surface in a dry, well-ventilated area. The antenna is designed to withstand a normal rain shower; however, water resistance cannot be guaranteed if the antenna is submerged.

* **DO NOT SHIP VIA RAIL:** Ensure not to ship any system via rail.

* **DO NOT STORE THE ANTENNA WRAPPED IN A TARP, TENT, VINYL, OR OTHERS:**

To avoid damage to radome paint, do not use a cover on the radome. Using any type of cover may cause paint damage. Intellian radomes are designed to withstand exposure to rain, humidity, and sun/UV rays when assembled according to Intellian instructions, and when the supplied approved hardware and sealants are used. Under no circumstances should an Intellian radome be covered by any protective covering that adheres, bonds, or clings to the surface, whether by self-adhesion or tension.

* **DO NOT FORCE THE LOGO FILM OFF FROM THE RADOME:**

The Intellian label sheet film has strong adhesive, and attempting to remove it forcefully may damage the paint. Therefore, removal is not recommended. If a radome without a logo is preferred, please ensure that a non-logo radome is specifically ordered. For logo repairs, use a heat gun with special care; otherwise, there is a risk of damaging the paint, and the warranty might be void.

Chapter 2. Certifications

FCC Part 15 Subpart B Declaration of Conformity (DoC)

We, Intellian Technologies, Inc. located at 18-7, Jinwisandan-ro, Jinwi-myeon (Chungho-ri), Pyeongtaek-si, Gyeonggi-do 17709 Korea declare under our sole responsibility that the product(s) described in the below to which this declaration relates is in conformity with the requirement of the FCC Part 15 Subpart B.

Product Information:

Product Name(s):	Intellian s100N, 109cm Ku-band Maritime TVRO Antenna System Intellian s130N, 125cm Ku-band Maritime TVRO Antenna System
Model Number(s):	T4-107XXX, T4-137XXX

Test Result

Standard	Requirement	Rule Section	Test Report Number	Result
FCC Part 15 Subpart B	Conducted Disturbance	ANSI C63.4:2014	DREKFCC2206-0117	Pass
	Radiated Disturbance	ANSI C63.4:2014	DREKFCC2206-0117	Pass

Supplementary Information:

Testing Organization	DT&C Co., Ltd. 42, Yurim-ro, 154 beon-gil, Cheoin-gu, Yongin-si, Gyeonggi-do 17042, Korea
Technical/Compliance File Held by:	Intellian Technologies, Inc. 18-7, Jinwisandan-ro, Jinwi-myeon, Pyeongtaek-di, Gyeonggi-do 17709 Korea
Place and Date of issue:	Gyeonggi-do, Korea on 17 June, 2022

Authority: **Yeonho Kim**
/ CTO, R&D

Signature:  _____

Date: August, 23, 2022

APAC
Headquarter/Innovation Center
18-7, Jinwisandan-ro, Jinwi-myeon
Pyeongtaek-si, Gyeonggi-do
17709 Korea
T +82 31 379 1000

EMEA
Rotterdam Office
Sheffieldstraat 18, 3047AP, Rotterdam,
The Netherlands
T +31 1 0820 8655

AMERICAS
Irvine Office
11 Studebaker
Irvine, CA 92618 U.S.A.
T +1 949 727 4498

RED Declaration of Conformity (DoC)

We, Intellian Technologies, Inc. located at 18-7, Jinwisandan-ro, Jinwi-myeon, Pyeongtaek-si, Gyeonggi-do 17709, Korea declare under our sole responsibility that the product(s) described in the below to which this declaration relates is in conformity with the *essential requirements* and *other relevant requirements* of the Radio Equipment Directive (2014/53/EU).

Product Information:

Product Name(s):	Intellian s100N, 109cm Maritime TVRO Antenna System Intellian s130N, 125cm Maritime TVRO Antenna System
Model Number(s):	T4-107XXX, T4-137XXX

To provide the presumption of conformity in accordance to Annex III(encompassing Annex II) of Directive 2014/53/EU; the following harmonized standards and normative documents are those to which the product’s conformance is declared, and by specific reference to the essential requirements of Article 3 of the Directive 2014/53/EU.

2014/53/EU Article	Standard(s) Applied in Full	Result
SAFETY (Art 3.1.a)	EN IEC 62368-1:2020+A11:2020	Pass
EMC (Art. 3.1.b)	EN 301 843-1	Pass
SPECRTUM (Art. 3.2)	EN 303 372-1	Pass

Supplementary Information:

Notified Body Involved: (Testing Organization) - Safety, EMC, SPECTRUM	DT&C Co., Ltd. 42, Yurim-ro, 154 beon-gil, Cheoin-gu, Yongin-si, Gyeonggi-do 17042, Korea
Technical/Compliance File Held by:	Intellian Technologies, Inc. 18-7, Jinwisandan-ro, Jinwi-myeon, Pyeongtaek-di, Gyeonggi-do 17709, Korea
Place and Date of issue:	Gyeonggi-do, Korea on 23 June. 2022

Authority: **Yeonho Kim**
 / CTO, R&D

Signature: _____

Date: _____ **23th Aug 2022**

Intellian Technologies USA, Inc.
US Headquarters
11 Studebaker
Irvine, CA 92618 USA
Tel: +1 949 727 4498

Intellian Technologies, Inc.
EMEA & APAC Headquarters
348-5 Chungo-Ri, Jinwi-Myeon
Pyeongtaek-Si, Gyeonggi-Do, 451-862 Korea
Tel: +82 31 379 1000

Doc Number IT22-DC0207-02

UK-CA Declaration of Conformity

We, Intellian Technologies, Inc. located at 18-7, Jinwisandan-ro, Jinwi-myeon, Pyeongtaek-si, Gyeonggi-do 17709, Korea declare under our sole responsibility that the product(s) described in the below to which this declaration relates is in conformity with the *essential requirements* and *other relevant requirements* according to UK legislation Electrical Equipment (Safety) Regulations 2016 (S.I. 2016/1101).

Product Information:

Product Name(s):	Intellian s100N TVRO Antenna System Intellian s130N TVRO Antenna System
Model Number(s):	T4-107BT3, T4-137BT3

To provide the presumption of conformity in accordance to Annex III(encompassing Annex II) of Directive 2014/53/EU; the following harmonized standards and normative documents are those to which the product’s conformance is declared, and by specific reference to the essential requirements of Article 3 of the Directive 2014/53/EU.

2014/53/EU Article	Standard(s) Applied in Full	Result
SAFETY (Art 3.1.a)	EN 62368-1	Pass
EMC (Art. 3.1.b)	EN 301 843-1	Pass
SPECTRUM (Art. 3.2)	EN 301-360 EN 301-459 EN 303-978	Pass

Authority: Yeonho.Kim
/ CTO, R&D

Signature:  _____

Date: August 1, 2022

Doc Number IT22-DC0721-05

APAC
Headquarter/Innovation Center
18-7, Jinwisandan-ro, Jinwi-myeon
Pyeongtaek-si, Gyeonggi-do
17709 Korea
T +82 31 379 1000

EMEA
Rotterdam Office
Tempelhof 12
3045 PV, Rotterdam
The Netherlands
T +31 1 0820 8655

AMERICAS
Irvine Office
11 Studebaker
Irvine, CA 92618 U.S.A.
T +1 949 727 4498

Chapter 3. Introduction

3.1 Introduction of s130N

Intellian's s130N WorldView™ is a digital marine satellite antenna system specifically designed for reception of worldwide Ku-band satellites, as well as the DIRECTV® services, enabling seamless and uninterrupted satellite TV reception across multiple coverage areas and service providers.

The dual-band 3-axis marine satellite antenna system is capable of receiving two Ka-band satellite signals and one Ku-band signal for DIRECTV® North American programming, making all channels available for viewing simultaneously. The Intellian Ku and Ka-band WorldView™ Trio LNB™ with triple feed horn selects a satellite television provider and connects to a satellite receiver. The WorldView™ Trio LNB can then automatically switch frequency, depending on the region the antenna is operating in.

All Intellian antenna systems are designed, manufactured, and tested to meet industry standards for vibration and shock in nominal weather conditions.

3.2 Features of s130N

Simultaneous Reception of DIRECTV® Ka and Ku-band

The antenna solution incorporates 3 feed horns to simultaneously receive 3 satellites: 2 DIRECTV® 99° and 103° Ka-band satellites and 1 DIRECTV® 101° Ku-band satellite. This allows viewers of satellite programs to watch every DIRECTV® channel without changing satellites.

User Friendly Five Cable Configuration

A user friendly, five cable configuration for global TVRO installers and engineers. There are four independent RF cables that connect the Worldview™ LNB to the multi-switch directly and one power cable that is connected to the ACU.

All New Hardware & Standardized Modular Components

All New hardware and pedestal based on our quality proven VSAT terminals. Modular components are used throughout the new TVRO range, such as dynamic motor brakes with integrated encoders, the Main Control Unit, and the skew assembly. By sharing common modules across Intellian's new TVRO antenna line, the number of spare parts required is reduced.

Hands-Free WorldView™ Trio LNB

The built-in Worldview™ Trio LNB module will automatically switch to the corresponding polarization and local frequency to receive the target satellite signal. This allows users to enjoy any satellite TV service around the world without the need to switch LNBS.

Unlimited Azimuth Range

This Intellian-only solution allows the system to operate in an unlimited azimuth rotating range. It prevents cable problems, such as disconnecting, cutting, and wrapping, that might otherwise occur in the field.

DVB-S2 Digital TV Receptions

Some of the HD TV services have moved to DVB-S2 transmission formats and there will be more in the future. Thanks to Intellian's groundbreaking DVB-S2 digital TV technology, now boaters are able to enjoy their favorite Sat TV entertainment at sea—just like at home.

19-inch Rack-mount Type ACU (Antenna Control Unit)

Intellian s130N ACU offers a pre-programmed global satellites library and provides the power to the antenna. Detailed information and satellite changes are displayed on an OLED display on the ACU front panel.

Multi Switch Module

The Intellian multi-switch module provides simple connections to different types of satellite receivers. The built-in SWM outputs and standard multi-switch outputs support both single wire and standard installations. This reduces the need for additional hardware and reconfiguration of the system when viewing programs on multiple TV screens.

AptusNTV Wireless Connectivity

Intellian's all new integrated M&C platform AptusNTV provides a responsive web user interface. The Installation Wizard function configures the antenna system automatically and minimizes operators' work on system installation and operation. Any kind of wireless device, such as a PC, laptop or smartphone, can connect to the ACU to manage and control the antenna system.

Chapter 4. Planning Installation

The antenna installation requires extreme precaution and safety measures given its size and weight. Failure to follow the correct installation process may lead to injury of the installer and/or cause damage to the system. To maximize the performance of the system, a thorough review of this installation guide is strongly recommended. In addition, you should execute the installation process as it is noted in this manual.



CAUTION

DO NOT OPERATE THE ANTENNA WITHOUT THE RADOME. THIS WILL RESULT IN DAMAGE TO THE ANTENNA AND ABNORMAL OPERATION.

4.1 Selection of Installation Site

The system should be placed in an area onboard the vessel with little to no RF signal blockage. The antenna unit should have direct line-of-sight with the desired satellite without any obstacles in the beam path. Minimum distances between the antenna and other onboard devices must also be considered during installation. Install the antenna in accordance with the following procedures to ensure maximum performance.

4.1.1 Minimize Satellite Blockage

The ideal antenna site should have a clear view of the horizon or satellite with all around clearance. Make sure there are no obstacles within the EL range -15° to $+115^{\circ}$ from the center of the antenna. Any obstacles can prevent the antenna from tracking the satellite signal.

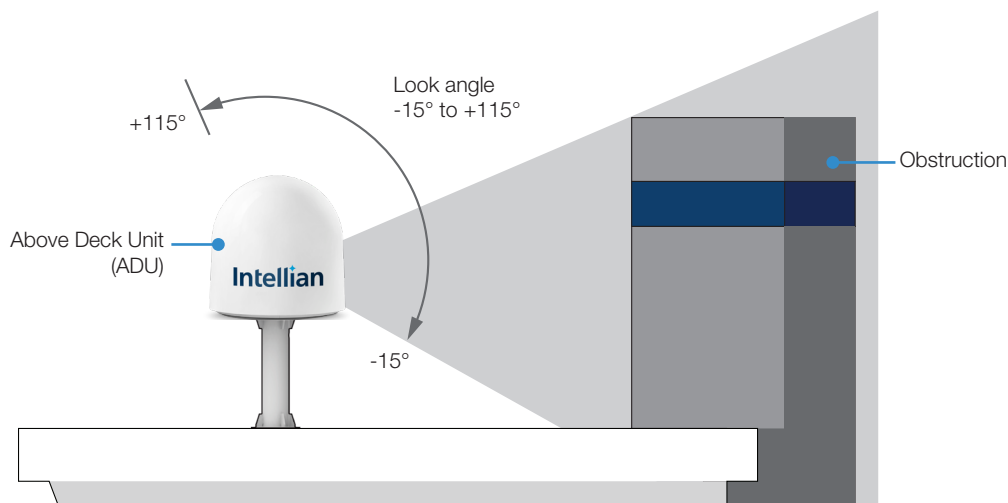

Figure 1: Elevation Limit of Obstacles

4.1.2 Avoid RF Interference

Do not install the antenna near the high power shortwave radar. Most radar transmitters emit RF energy within an elevation range of -15° to $+15^{\circ}$. For this reason, you should position the antenna at least 15 feet (4.6 m) away from the radar.

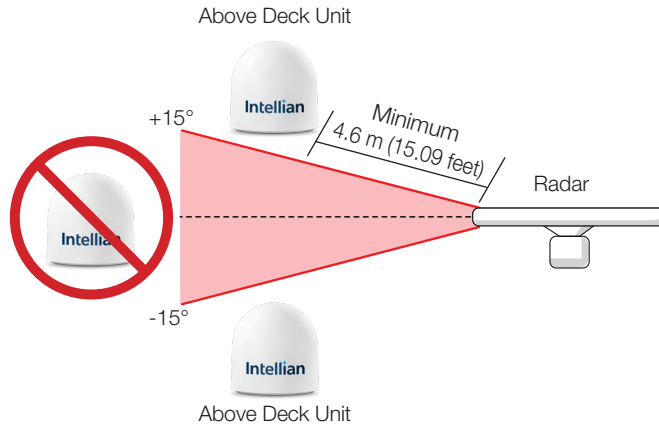

Figure 2: Potential RF Interference



WARNING

Never place the antenna in the beam path of the radar, regardless of distance. The high power shortwave radar may impair its performance or damage the antenna.

4.2 System Package

4.2.1 Above Deck Unit (ADU)

The ADU includes an antenna pedestal inside a radome assembly unit. The pedestal consists of a satellite antenna main dish with RF components mounted on a stabilized pedestal. The radome protects the antenna pedestal assembly unit from the severe marine environment.



Figure 3: Radome and Pedestal

4.2.2 Antenna Control Unit (ACU)

The ACU provides power to and controls the various settings of the antenna. ACU features include the following:

- OLED display
- USB port to download logs and upgrade firmware (no PC required)
- Wi-Fi access
- AptusNTV web application



Figure 4: Front Panel of ACU



Figure 5: Back Panel of ACU

4.2.3 Multi Switch Module (MSM)

The Intellian Multi-Switch Module provides built-in SWM and standard multi-switch outputs, allowing configuration with DIRECTV satellite receivers and standard satellite receivers.



Figure 6: Front Panel of MSM

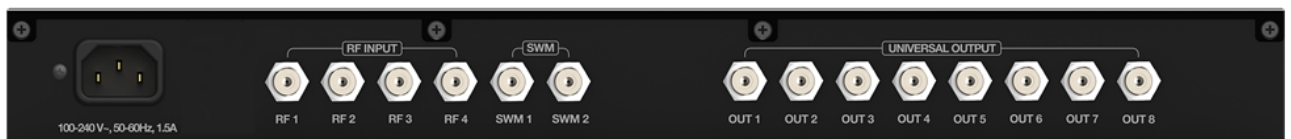

Figure 7: Back Panel of MSM

4.2.4 Packing List

Before beginning installation, make sure you have all the included components.

s130N Package

Item	Q'ty	Size	Description
Above Deck Unit (ADU)	1		Radome and pedestal
Below Deck Unit (BDU)	1	431 mm x 411 mm x 44 mm	Antenna Control Unit (ACU)
Quick Installation Guide (QIG)	1		Installation guide
Mounting Template	1		Real size drawing of antenna mounting hole pattern
ACU Rack Mount Bracket	2		For installing ACU to 19-inch rack
Flat Head Screw	10	M4 x 12L	
AC Power Cord (CEEE7/7)	1	1.5 m	Power cord for ACU (220 V)
Ethernet Cable (RJ45 to RJ45)	1	1 m	To connect ACU to PC
Wi-Fi Dongle	1		For Wi-Fi connection
Hex Bolt-S F	5	M12 x 80L	Bolt kit for antenna-deck (mast) assembly (1 spare set included)
Hex-S Bolt-S F	5	M6 x 40L	Bolt kit for radome assembly (1 spare set included)
Cable Tie	20	140 mm	For mounting cables

MSM Package

Item	Q'ty	Size	Description
Multi-Switch Module (MSM)	1	431 mm x 411 mm x 44 mm	Multi-Switch Module for s-Series
MSM Rack Mount Bracket	2		For Installing MSM to 19-inch rack
Flat Head Screw	10	M4 x 12L	
8-way splitter for SWM	2		SWM (on MSM) to DIRECTV receivers
AC Power Cord (CEEE7/7)	1	1.5 m	Power cord for MSM (220 V)

4.3 System Cables (Customer Supplied)

4.3.1 RF Cables (Customer Supplied)

Due to the signal loss across the length of RF coaxial cable on L-Band, only use 75 Ω coaxial cable types for the RF cables in a standard system installation. The use of different types of cables (50 Ω coaxial types, etc.) can cause problems. If you need RF cables that run longer than the maximum cable length recommended, contact Intellian Technical Support for assistance.

Cable Requirements(Antenna Cable/ RF1 ~ RF4 Cable)

Coaxial Cable Type	Connector	Max. DC Resistance	Attenuation @ 2GHz	Max. Cable Length (\leq 16dB loss @ 2GHz)
LMR300-75	F (M) to F (M)	0.8 Ω (Antenna cable only)	0.279 dB/m	50 meters
LMR400-75			0.187 dB/m	80 meters



NOTE

- Optimal tightening torque for F type RF connector: 1.0 N-m
- Maximum RF loss at 2 GHz: 16 dB including connectors

4.3.2 Gyrocompass Cable (Customer Supplied)

The following general types of gyrocompass cables are recommended for compatible connection to Intellian antennas used in various environments.

Standard	NMEA 2000	NMEA 0183
Connector Type	Micro-C 5 pin connector	2 pin terminal block connector
Cable Type	5-wire single cable	2-wire cable with one enclosed shield cable
Heading Information	Supports PGN, 127250: Vessel Heading	Supports \$HEHDT, baud rate 4800, format 8N1 as standard

4.4 Unpacking System Package



CAUTION

- The package box on the pallet should be lifted by a forklift.
- Follow the steps in order for easy and safe unpacking.

The pallet should be lifted by a forklift. To unpack the wooden crate, follow the procedure below.

1. Open the side panel with an attached sticker paper (*Wooden Crate Unpack Guide*) by removing the fixing screw (1 ea) and clips (8 ea).

1-1 : 1 ea

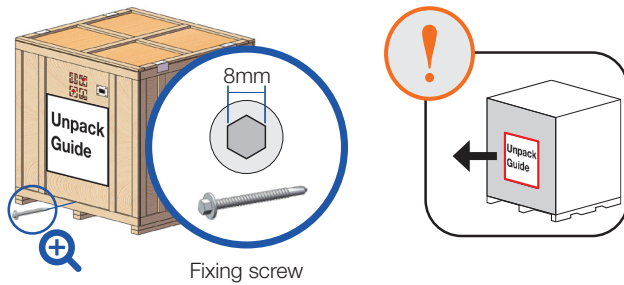

1-2 : 8 EA

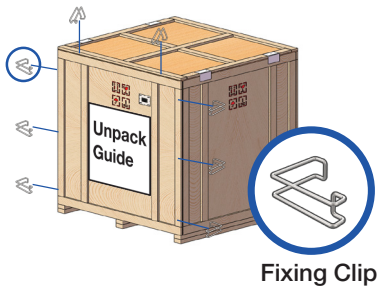

1-3

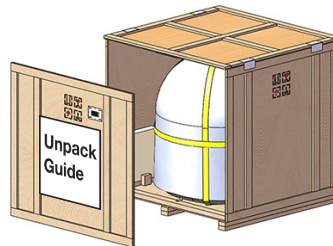

2. The ACU box is placed inside of the side panel. Remove the fixing screws (2 ea) from the holding bracket, and then remove the ACU box from the crate.

2

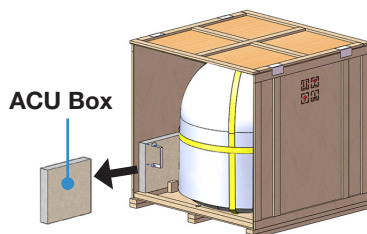

3. Remove the clips (6 ea) on the top panel, and then detach the top panel by carefully pulling it as shown in the figure below.

3-1 ⇐ : 6 ea

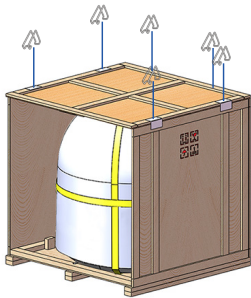

3-2

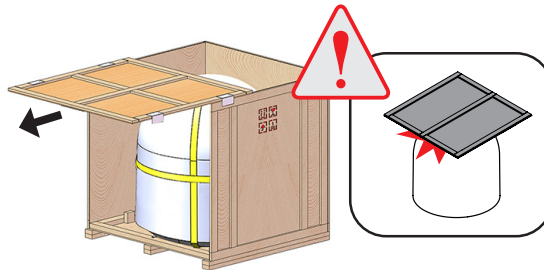

4. Remove the fixing screws (3 ea side/1 ea back) that secure the side panel (right) and back panel, and then detach the panels.

4 ⇐ : 4 ea

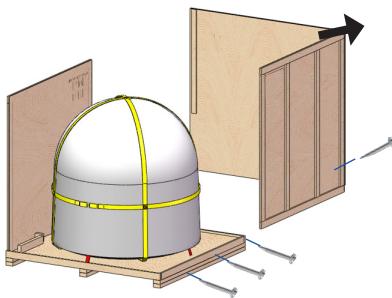

5. Remove the fixing screws (2 ea) from the MSM box holding bracket (located on the left side panel), and then remove the MSM box from the crate.

5

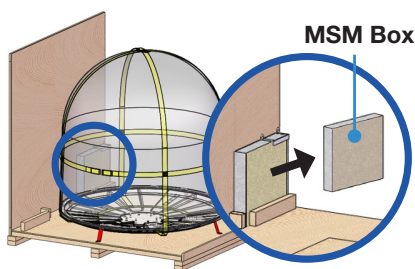

6. Remove the fixing screws (3 ea) that secure the side panel (left), then detach the panel.

6-1 ⇐ : 3 ea

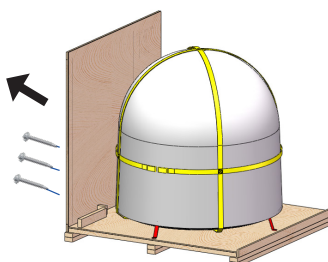

6-2

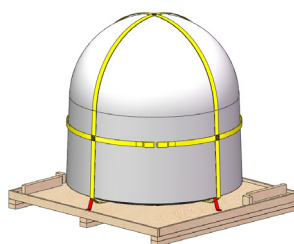

Chapter 5. Installing Above Deck Unit (ADU)

5.1 Antenna Dimensions

Before installing the antenna unit, confirm its height and diameter (see figure below). The mounting surface and overall space occupied by the antenna must be sufficient for the fully constructed radome on top of its base frame. Using a crane during the antenna installation is strongly suggested.

Unit: mm (inches)



Figure 8: Antenna Side View



NOTE

Position the antenna with the BOW direction parallel to the center line of the ship.

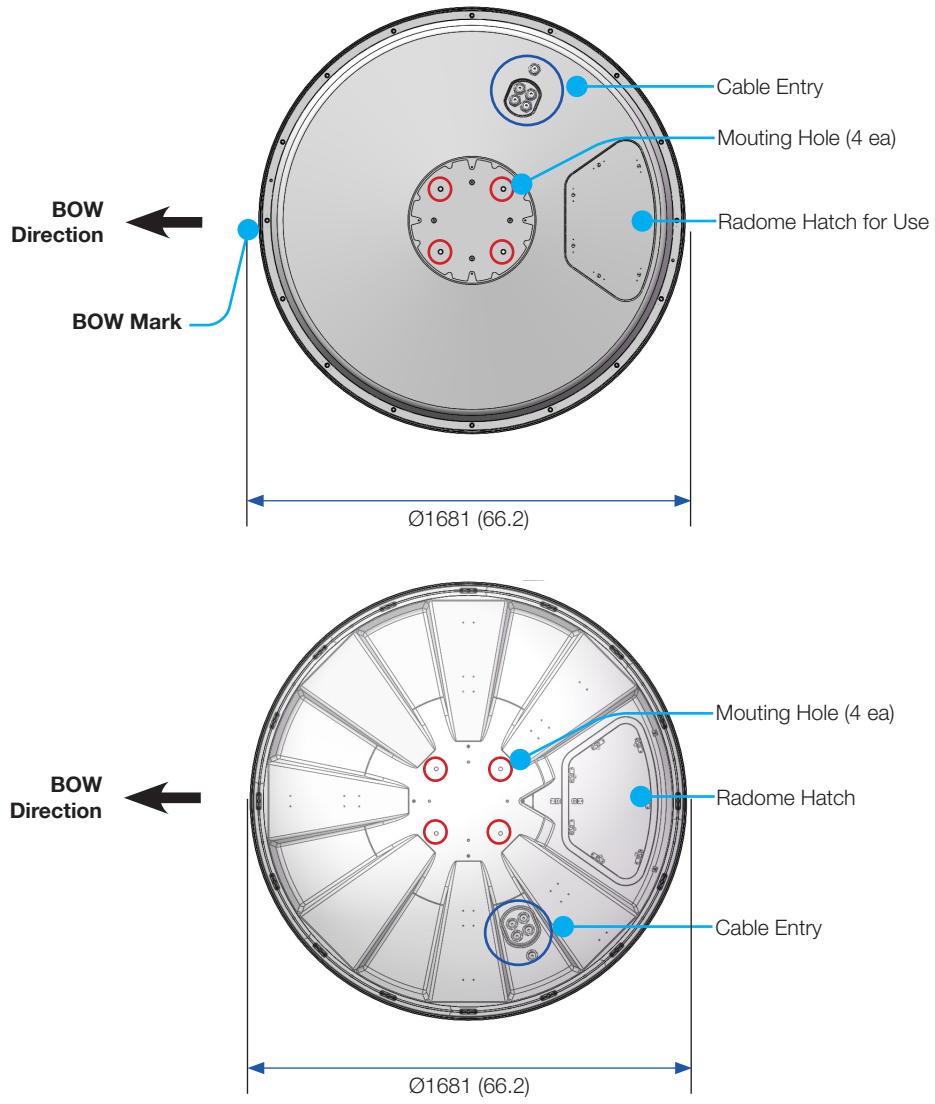

Figure 9: Antenna Bottom View (Outside/Inside)

5.2 Antenna Mounting Hole Pattern

Use the supplied mounting template when drilling mounting holes on the mast. The hole placement for the antenna must match the mounting hole pattern on the template.



WARNING

When reusing an existing mast, make sure the location of the holes on the mast correspond to the hole locations and sizes printed on the mounting template.

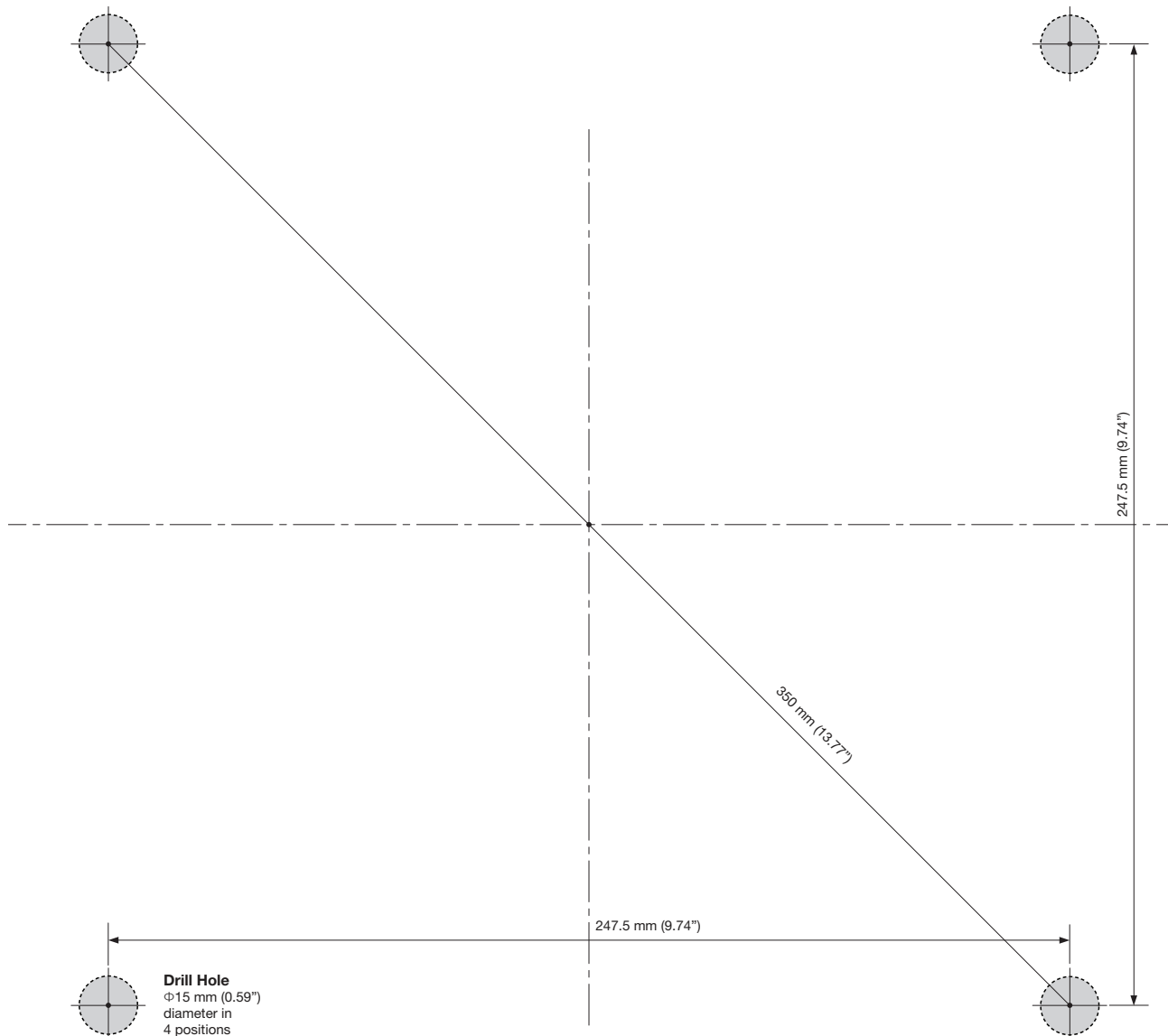

Figure 10: Antenna Mounting Hole Template

5.3 Designing Mast (Example Only)

The installation mast must be robust enough to prevent flex, vibration, and sway when an external force is exerted on the mast with antenna and radome attached. Refer to the following mast drawings for more details.



NOTE

- This is a general example of designing a mast. The shape of mast may differ depending on the ship's environment.
- Follow the Intellian installation recommendations for safety.

WARNING

- When designing a mast, consider the minimum and maximum thickness of the mast plate marked on the diagram. If the thickness of the mast plate is different from the recommended size (Min. 10.0 mm/ Max. 20.0 mm), choose the bolt size for mounting the antenna on the mast according to the table below.



Mast Plate Thickness	Recommended Bolt Size
10 ~ 28 mm (Recommended)	M12 x 80L (Supplied)
28 ~ 35 mm	M12 x 90L

- To use the supplied bolts (M12 x 80L) for mounting the antenna on a mast, the thickness of the mast plate must be 10 ~ 20 mm. The minimum thickness of the mast plate is 10 mm. If the mast plate is thicker than 20 mm, the supplied antenna mast mounting bolts may be too short to mount the antenna on the mast securely.

Unit: mm (inches)

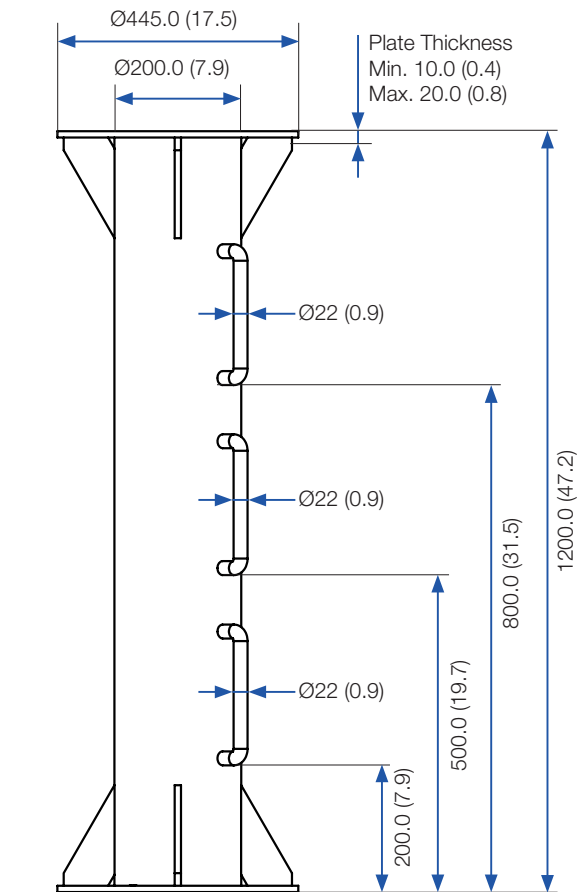
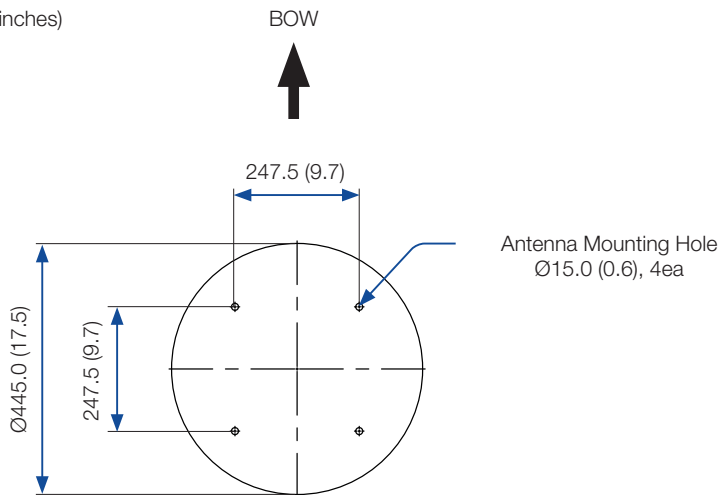

Figure 11: Recommended Size of Mast

5.4 Routing RF Cable on Mast (Example Only)

The cable must be routed from the antenna and through the ship to end up at the antenna control unit. When pulling the cables in place, avoid sharp bends, kinking, and excessive force. After placement, seal the deck penetration gland and tie the cable securely in place. Cable brackets must be installed on the mast to secure the cable. The gooseneck must be installed on the side of the mast to protect the cable from water.



WARNING

Ensure that cable has been run through watertight fittings to prevent water entry into the vessel when installation is completed.



NOTE

This is a general example of routing cables on the mast. The routing method may differ depending on the ship's environment.

Routing Cable on Outside of Mast

This method is generally recommended.

1. Route the cable from the gooseneck on the deck to the antenna as shown in the figure below.
2. Maintain sufficient cable length (at least 2 m) when routing the cable on the surface of the mast. After connecting the cable to the connector inside the radome, adjust the length and fix the cable on the cable brackets using cable ties.

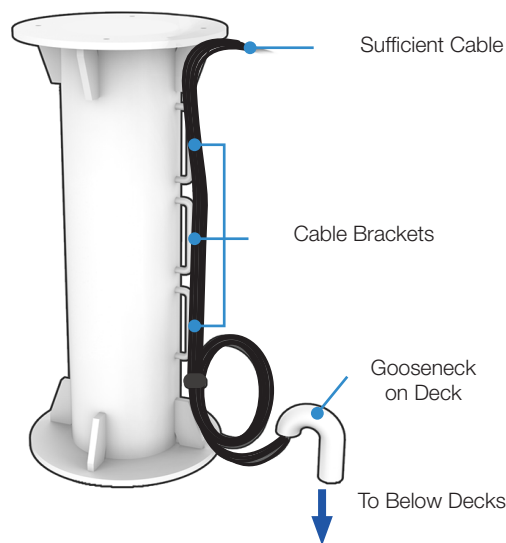
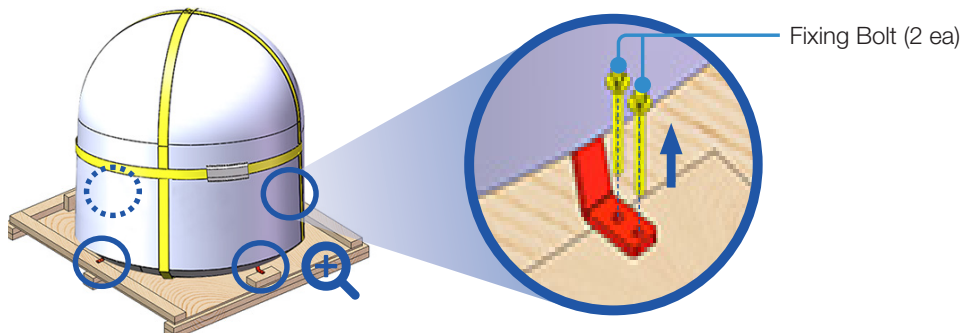

Figure 12: Routing Cable Through Outside of Mast

5.5 Removing Antenna from Wooden Pallet

Four radome brackets secure the antenna to the pallet. To remove the radome from the pallet and the brackets from the radome, use the following procedure.

1. Remove the hex head wrench bolts (2 ea) from each of the radome brackets (4 ea) using a wrench.



2. Check the condition of the lifting straps, and make sure the shackles (2 ea) are tightened. After checking the shackles, re-wrap them with the existing protection to avoid radome damage.

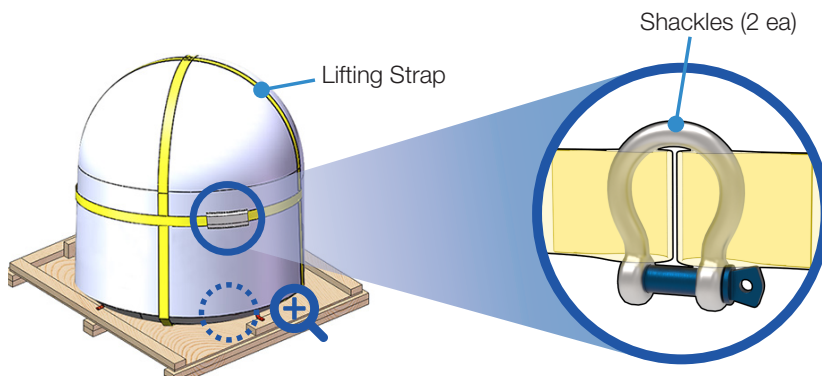

3. Lift the antenna above the pallet using a crane, and maintain a sufficient space (max. 100 mm) between the bottom of the antenna and the pallet to remove the shipping brackets.

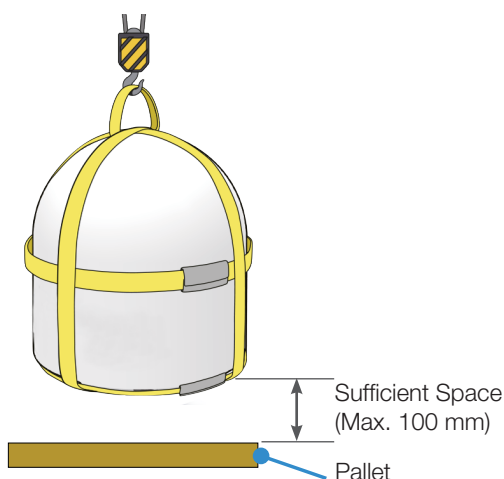

WARNING

- Before lifting the antenna, make sure that you have removed the bolts that secure the radome brackets to the pallet. Otherwise, the pallet will not separate from the antenna.
- Be careful when lifting heavy objects. Incorrect handling of heavy objects may lead to personal injury or significant equipment damage.

4. Remove the radome bracket bolt (1 ea) using a wrench, and then detach the radome bracket from the radome.
5. Find the supplied hex head wrench bolts (M6 x 40L), spring washers, and flat washers in the ACU box.
6. Apply Loctite #243 on the bolt, and assemble the bolt and washers to the radome by turning the bolt clockwise using a wrench.

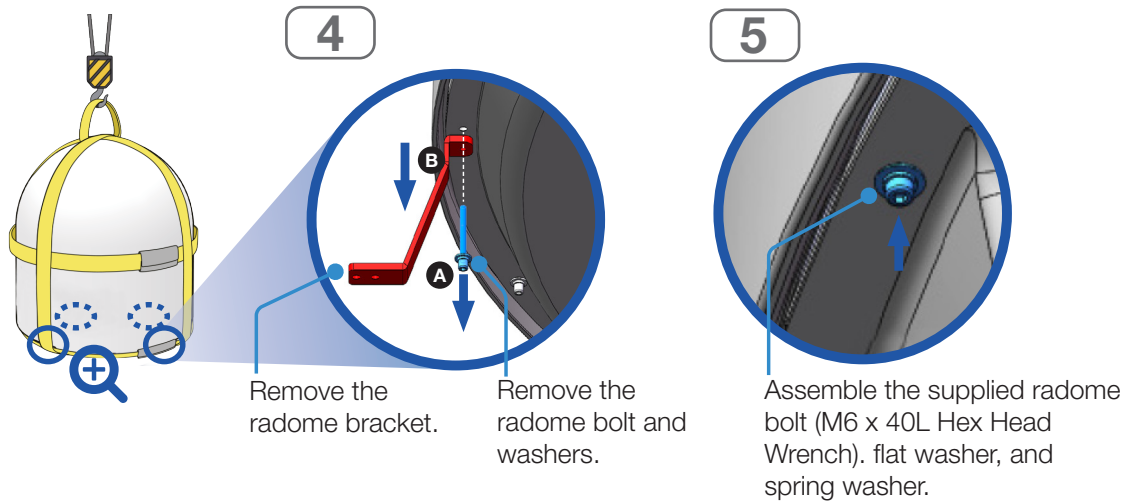

7. Repeat steps 4 through 6 for each remaining radome bracket.



CAUTION

- Fully tighten the radome bolt.
- Use the radome bolt and washers supplied in the ACU box.
- DO NOT reuse the removed bolts and washers.

5.6 Moving Antenna Above Mast

The Intellian antenna comes from the factory with the lifting straps pre-mounted.

1. Check the condition of the lifting straps and ensure the shackle is tightened up.
2. Lift and move the antenna above the mast using a crane, and then carefully move the antenna over the mast. Leave at least 150 mm of space between the bottom of the radome and the top of the mast.



WARNING

The antenna may sway in the wind when suspended by a crane. Be careful when handling the antenna.



NOTE

Position the antenna with the BOW direction parallel to the center line of the ship.

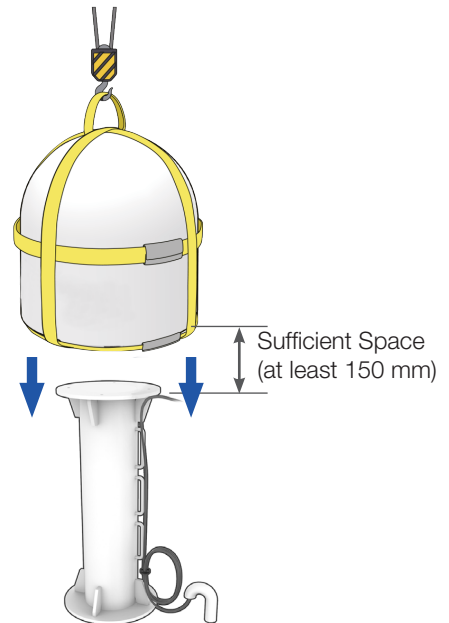

5.7 Mounting Antenna on Mast

1. Bring M12 x 80L hex bolt sets (4 ea) for antenna-mast assembly from the ACU box.
2. Lower the antenna onto the mast using the crane, making sure the mounting holes of the antenna are aligned with those of the mast. Check the positions of the BOW mark, cable glands, and cable brackets (see Figure 13) when mounting the antenna on the mast. Make sure the cable from the mast is aligned with the cable entry on the bottom of the antenna for stable connection.
3. Apply Loctite #263 to the bolt threads, insert the bolts and washers from under the mast into the built-in nuts on the bottom of the radome (see Figure 13), and then lightly tighten them by hand. Use a crisscross sequence as shown in Figure 14.
4. After installing all 4 bolts, fully tighten the bolts using a torque wrench in the crisscross sequence. Refer to **"12.1 Appendix A. Tightening Torque Specification"** on page 107.
5. Remove the lifting strap from the antenna.

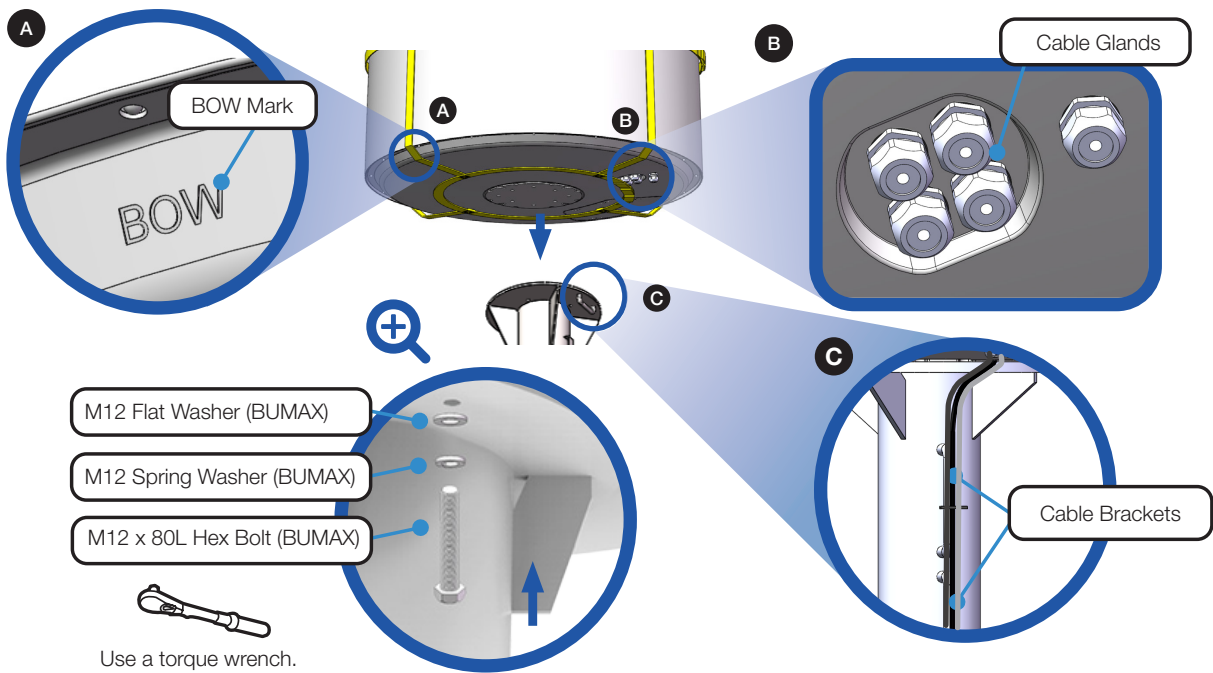

Figure 13: Installing Bolts for Antenna-Mast Assembly

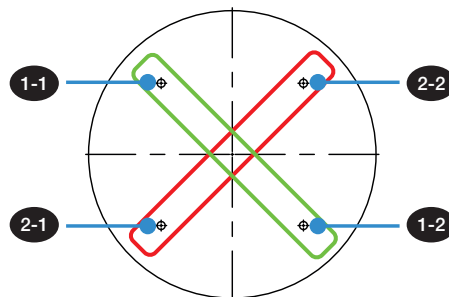

Figure 14: Installing Sequence of Bolts



NOTE

- Check the positions of the **A** BOW mark, **B** cable glands, and **C** cable brackets when mounting antenna on the mast.
- Make sure the cable from the mast is aligned with the cable entry on the bottom of antenna for stable connection.
- Refer to "**12.1 Appendix A. Tightening Torque Specification**" on page 107 for the bolt tightening torque.



WARNING

If a bolt does not fit into the mounting hole when installing the bolt by hand, stop installing and check the bolt size. **DO NOT** tighten the bolts forcefully. Forceful tightening can damage the inner threads of the antenna mounting holes. This type of damage is not covered by the warranty.

5.8 Connecting RF Cable to Antenna

To connect the system cable, access the inside of the radome through the radome hatch. Make sure that there is sufficient space to open the hatch underneath the radome. For the cable connections, terminate cables at each end using proper tools. After connecting the cables inside the radome, adjust the cable lengths and use cable ties to securely fix the cables on the cable brackets of the mast.



NOTE

Make sure of the following before installing system cables.

- All cables need to be well clamped and protected from physical damage and exposure to heat and humidity.
- Don't use any acutely bent cable.
- Use watertight glands or swan neck tubes at exposed bulkheads or deck heads where the cable passes through.
- Install recommended size cables. Refer to **"4.3.1 RF Cables (Customer Supplied)" on page 18** to see cable requirements.

1. Loosen the locking screws (slotted) (7 ea) using a flat head screwdriver, and then open the radome hatch.

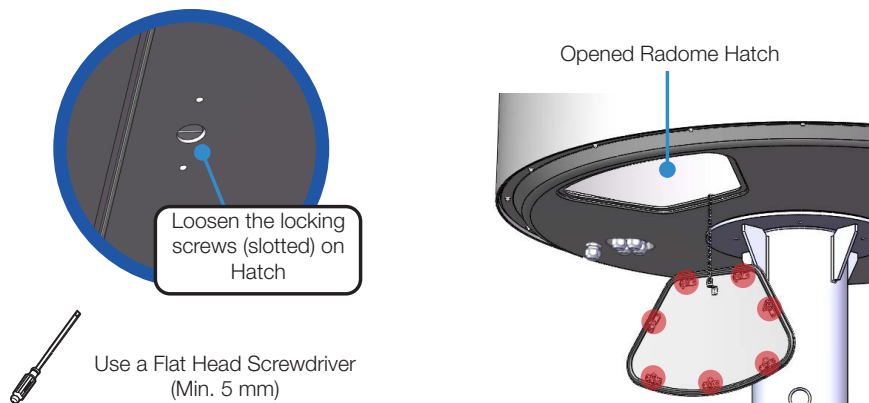

2. Insert the antenna cable from the ACU and the four RF cables (RF1, RF2, RF3 and RF4) through the cable glands into the base of the radome. Initially, assemble cable glands to temporarily to hold the cable in position. Use the cable gland assembly sequence shown in the figure below, but do not tighten the cable glands completely yet.

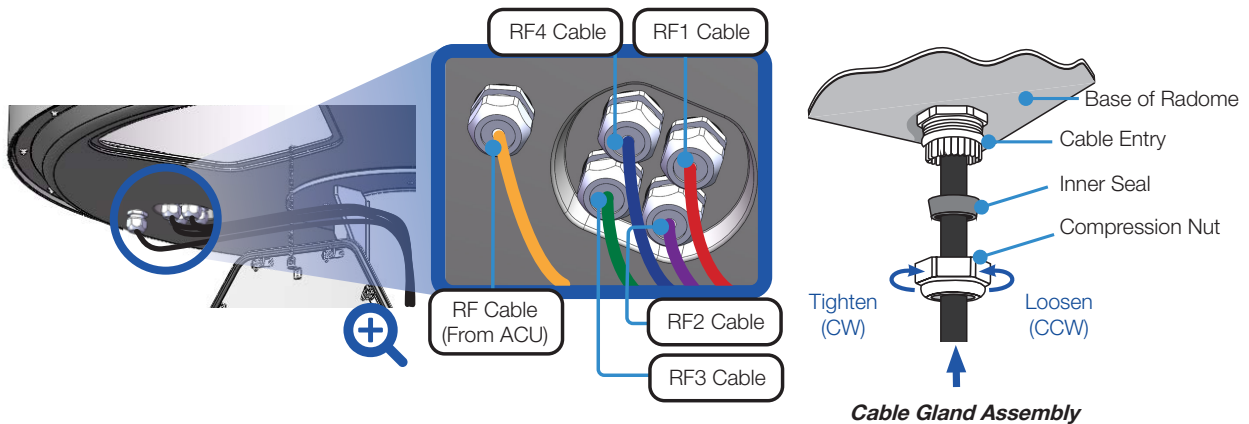
**NOTE**

- To prevent cable damage, insert the RF cable into the radome through the cable gland.
- The RF cable length inside the radome is approximately 0.7 m ($\pm 10\%$).
- The above descriptions are references. The cable location can be changed for user convenience.

3. Loosely tie the cables on the cable bracket using cable ties. Later in the procedure, after connecting the cables inside the radome, you'll be able to adjust the cable length and then securely fix the cables on the cable brackets.

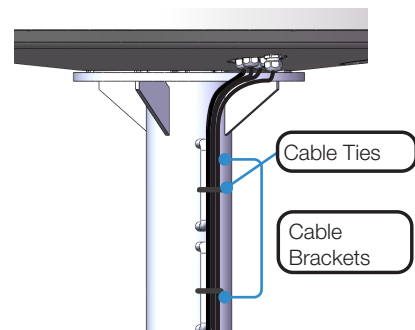

4. Terminate the RF cables with F (M) connectors inside the radome. Intellian recommends using genuine cable connectors and tools. Refer to the cable termination instructions provided by the connector manufacturers.
5. Connect the antenna cable (from ACU) to the power switch unit inside the radome (see Figure 15 and Figure 16).
6. Connect the RF1, RF2, RF3 and RF4 cables to the F-connectors on the RF1~RF4 bracket (see Figure 15).
7. Ensure the cables are firmly fastened to the connectors and fix them on the cable mounts inside the radome using cable ties (see Figure 15).
8. Fully tighten the cable glands at the base of the radome that you assembled temporarily in step 2.
9. Position the radome hatch, and then close it by installing the locking screws (slotted) (7 ea) using a flat head screwdriver.
10. Securely fix the cables on the mast cable brackets using the cable ties.

**WARNING**

Ensure that the power switch is off during installation. Do not turn on the power until after full installation is finished for both ADU and BDU.

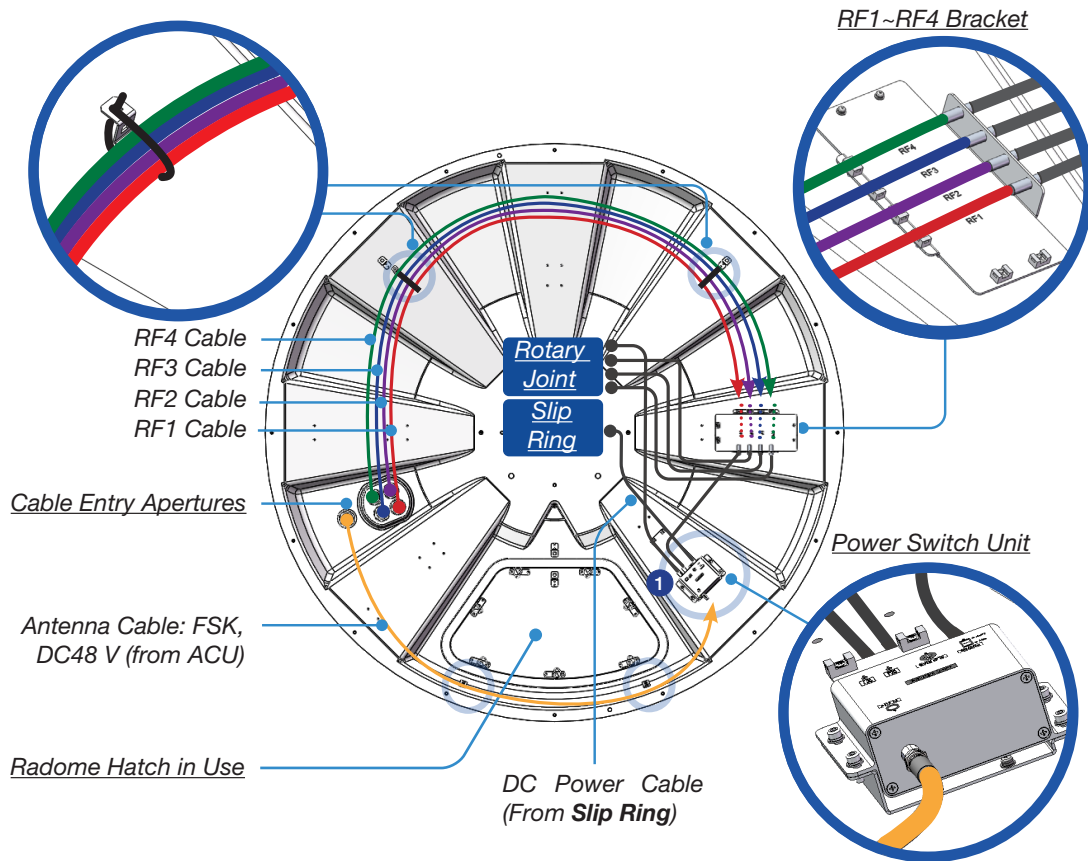

Figure 15: Cable Connection Inside Radome

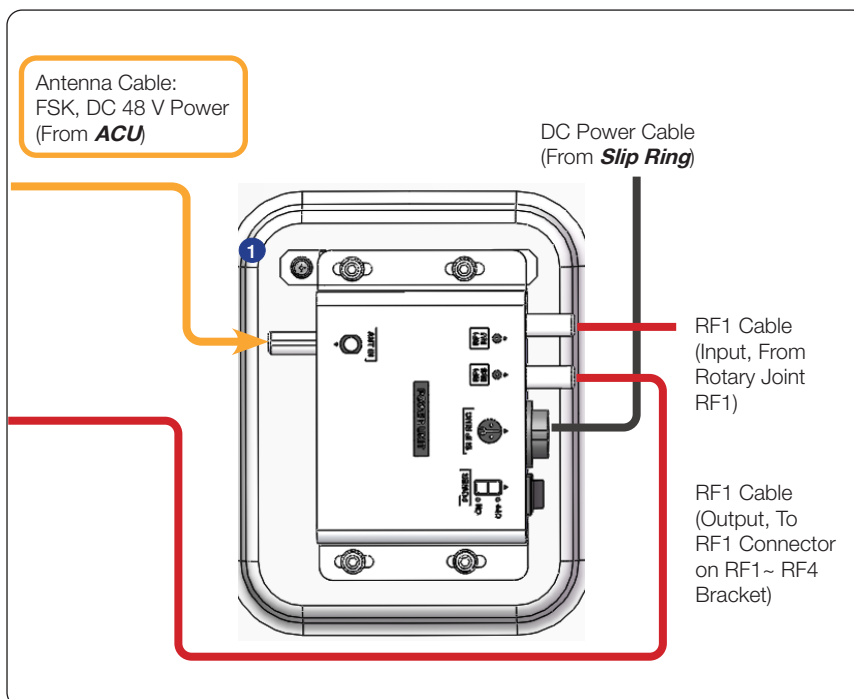

Figure 16: Cable Connections on Power Switch Unit

Chapter 6. Installing Below Deck Unit

6.1 Selection of BDU Installation Site

The ACU and MSM should be installed below the deck in a location that is dry, cool and ventilated. The front panel of the ACU and MSM should be easily accessible to users.



WARNING

This product is installed where the circuit breaker is connected to the power source.

6.2 ACU Dimensions

Confirm the dimensions of the ACU before installing it.

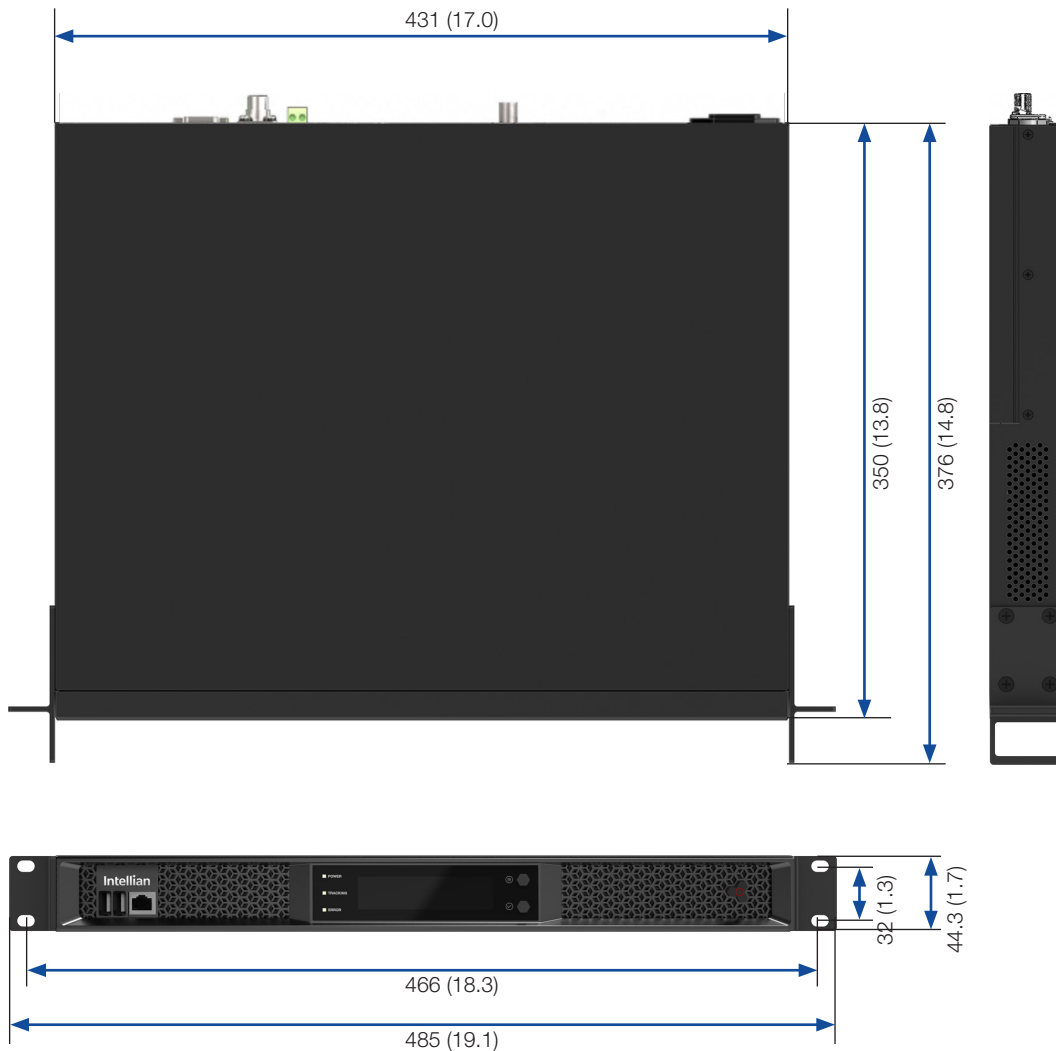

Figure 17: ACU Dimensions

6.3 MSM Dimensions

Confirm the dimensions of the MSM before installing it.

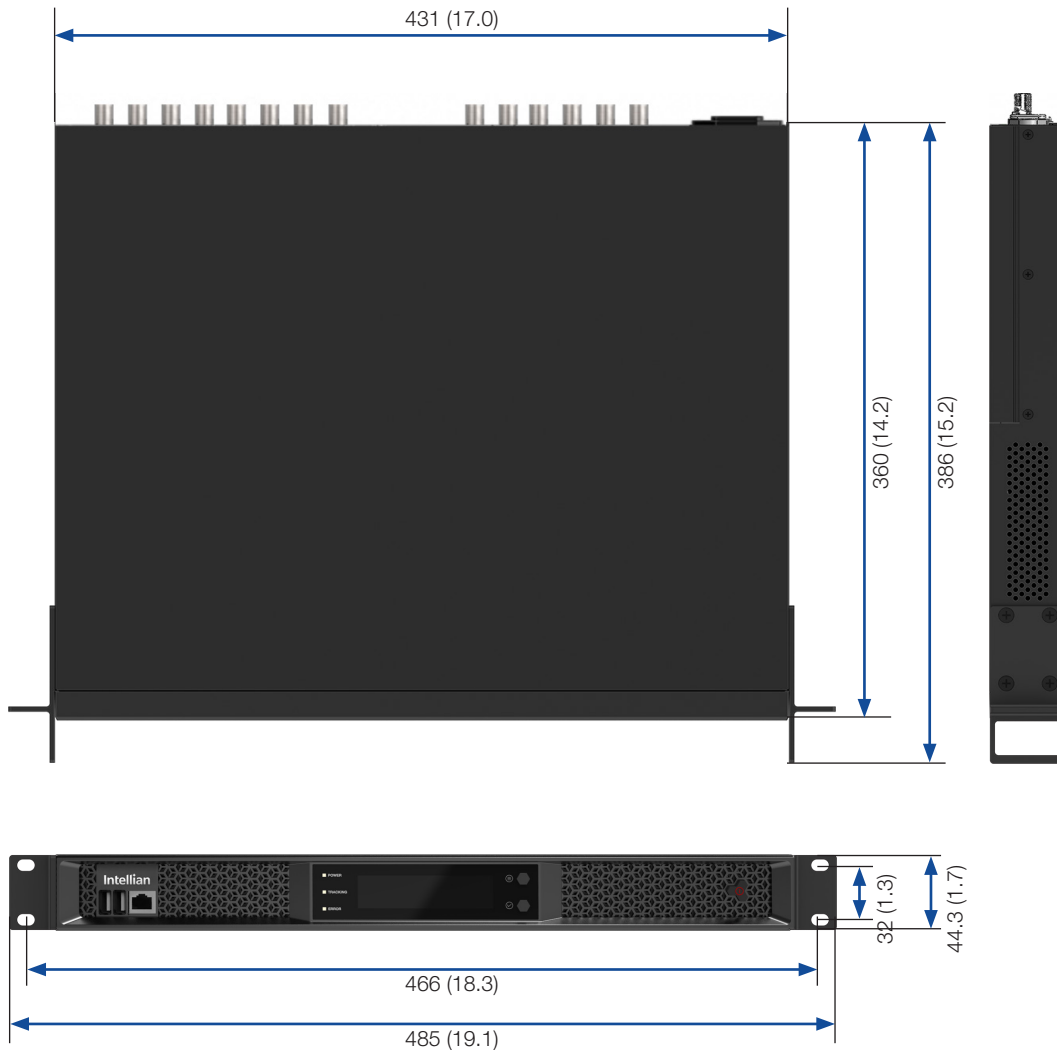

Figure 18: MSM Dimensions

6.4 Mounting ACU/MSM

Mounting ACU and MSM in a 19" Rack

The ACU and MSM can be installed in a 19" rack using the 4 rack mount brackets that are included in the ACU and MSM boxes. Attach the rack mount brackets to the sides of the ACU and MSM using the included M4 x 12L flat head screws (16 ea). Connect cables to the back side of the ACU and MSM.



Figure 19: 19" Rack Mount ACU (Applies to MSM)



WARNING

Ensure that the cables connected to the ACU and MSM are long enough to prevent damage when they are pulled out from the rack.

6.5 System Configurations

For the proper operation of the satellite communication system, the required components must be connected as shown in the figure. Separate purchase of a ship's gyrocompass may be needed.

6.5.1 Single Antenna System Configuration

The basic system consists of one antenna and one ACU. Connect the cables as shown in the configuration below.

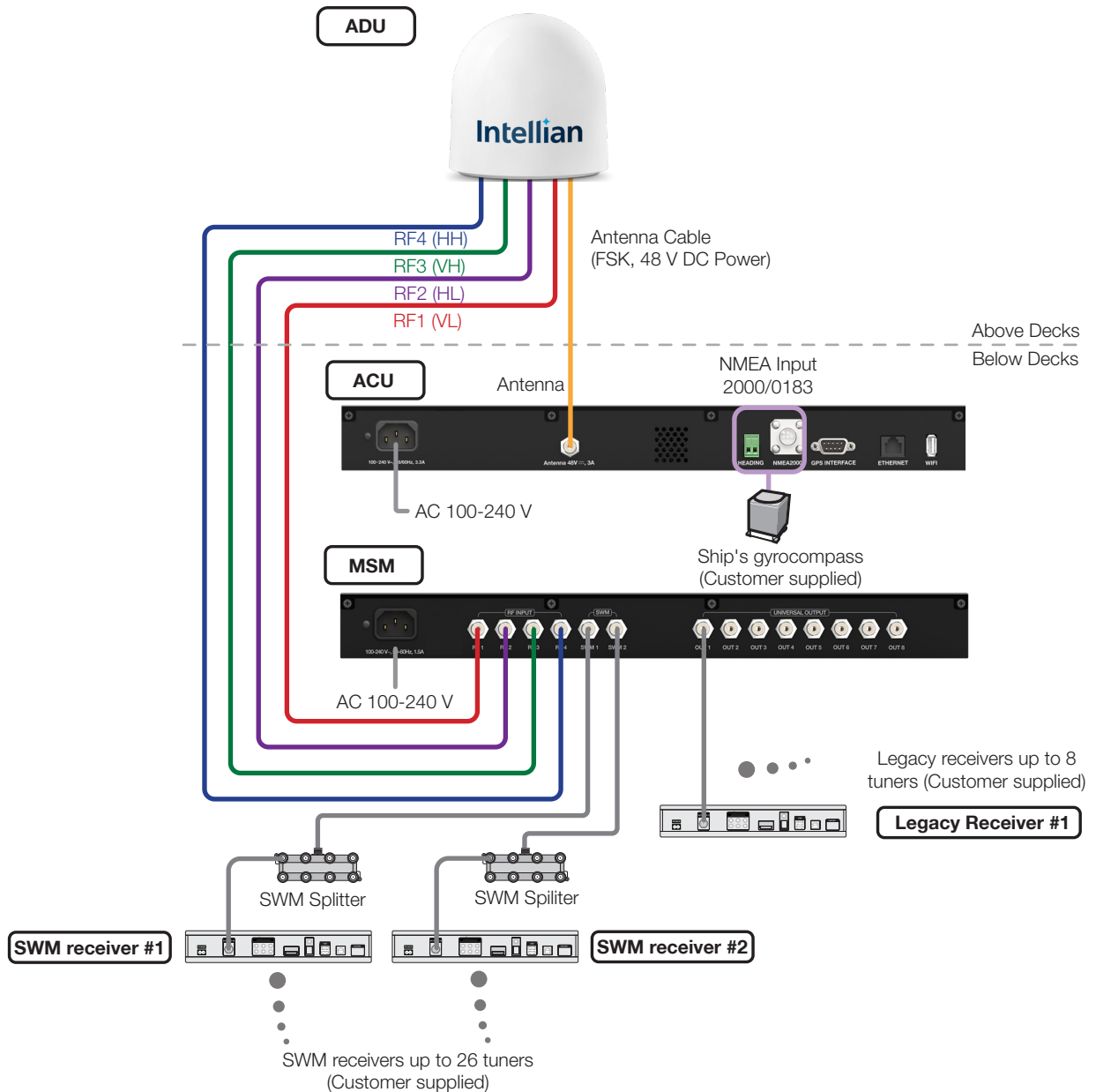

Figure 20: Single Antenna System Configuration (Basic Antenna System)

6.5.2 Dual Antenna System Configuration (Optional)

The dual system configuration consists of two TVRO antennas, two ACU and one Mediator. The new TVRO Mediator which is capable of controlling and managing two TVRO antenna systems simultaneously is sold separately. Connect the cables as shown in the configuration below.

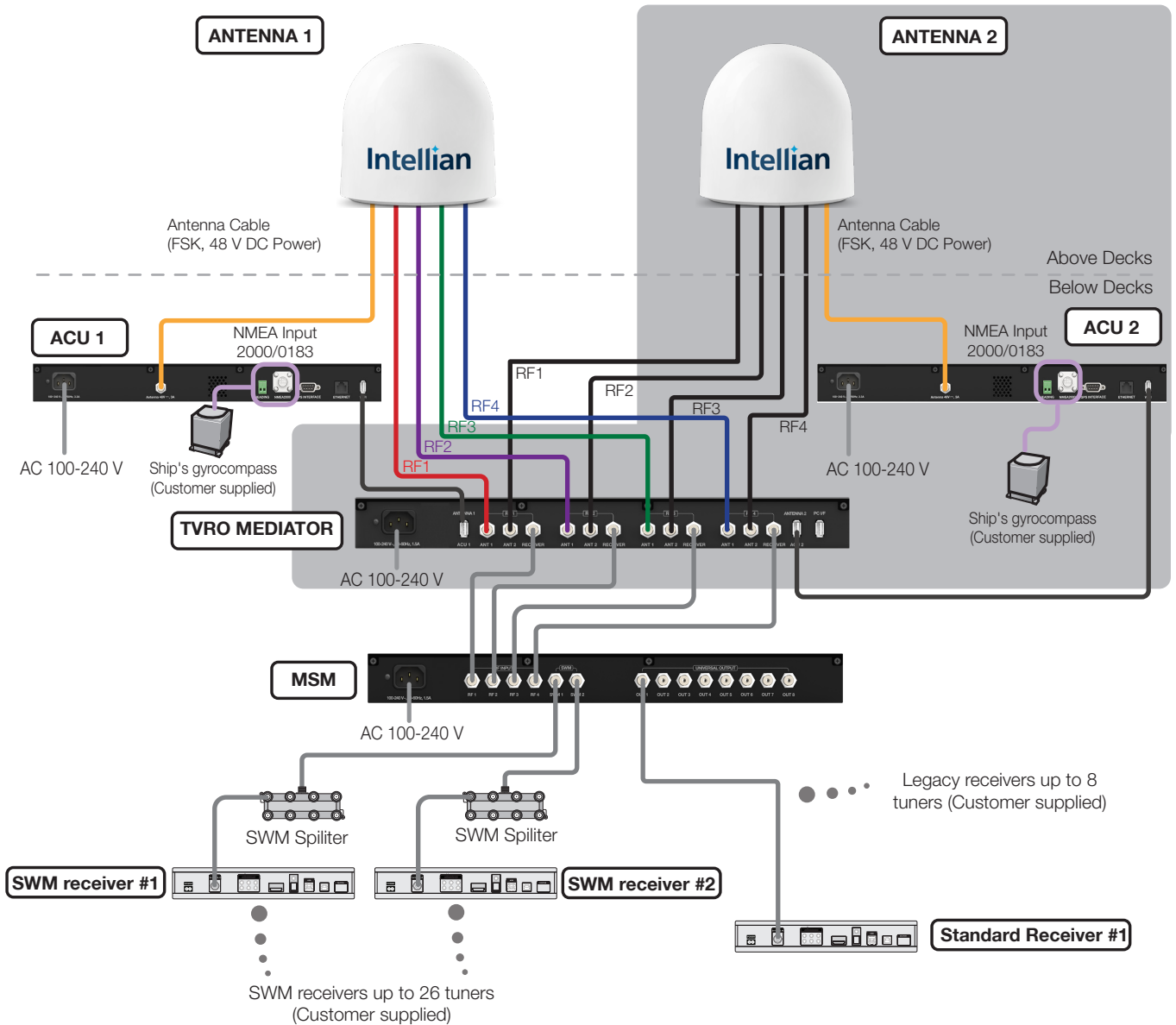

Figure 21: Dual Antenna System with Multi-Switch Connection Configuration



NOTE

The New Dual TVRO Mediator is sold separately.

6.6 BDU Cable Connection

6.6.1 ACU Back Panel Connectors

The following figure shows the ACU back panel connectors.

Below Deck -- (ACU)

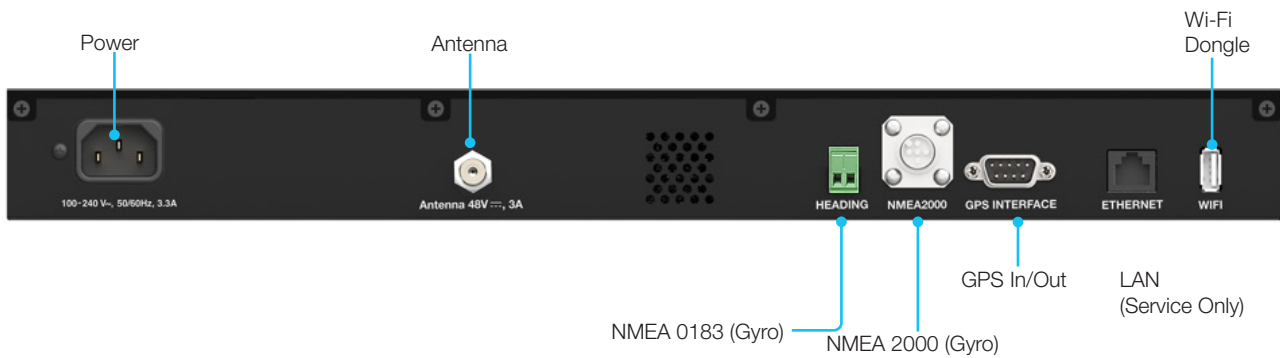

Figure 22: ACU Back Panel Connectors

6.6.2 MSM Back Panel Connectors

The following figure shows the MSM back panel connectors.

Below Deck -- (MSM)

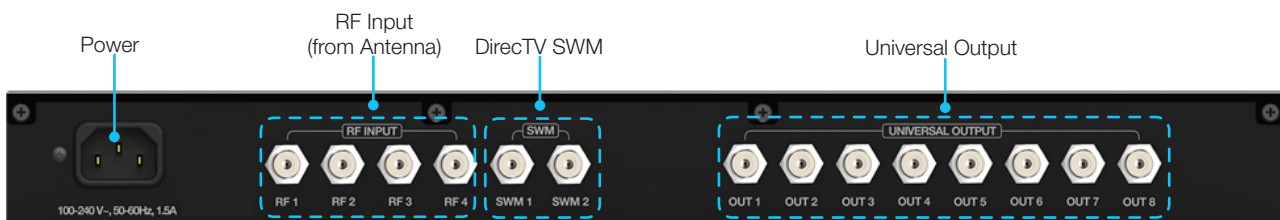
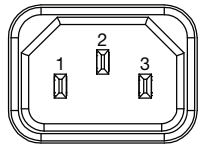

Figure 23: MSM Back Panel Connectors

6.6.3 ACU Connector Pinout Guide

Reference the following connector pinout information for the connection ports of the ACU.

Power Connector



IEC 320 C14 Plug Male

Pin	Signal
1	LIVE
2	GND
3	NEUTRAL

Antenna Connector

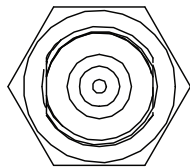

RF F Type Female

Conductor	Function
Inner	DATA, POWER
Outer	GND

HEADING (NMEA 0183) Connector

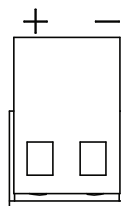

2-Pin Terminal Block

Conductor	Function
+	HEADING IN
-	HEADING GND

NMEA 2000 (Heading) Input

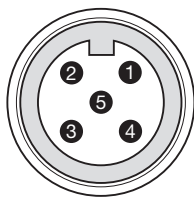

Micro-C 5-Pin Male

Pin	Signal
1	Shield
2	NETS, (power supply positive, +V)
3	NETC, (power supply common, -V)
4	NET-H (CAN-H)
5	NET-L (CAN-L)

GPS Connector

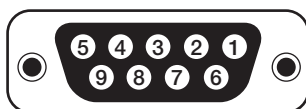

D-Sub 9-Pin Female

Pin	Signal
1	GND
2	GPS OUTA
3	N/C
4	N/C
5	GPS_IN
6	GPS_OUTB
7	N/C
8	N/C
9	GPS_GND

ETHERNET (LAN) Connectors

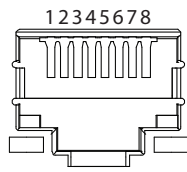

RJ-45 Female

Pin	Signal
1	TX-
2	TX+
3	RX-
4	N/C
5	N/C
6	RX+
7	N/C
8	N/C

Wi-Fi Dongle USB Connector

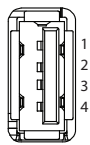

USB A Female

Pin	Signal
1	+5 V
2	DATA-
3	DATA+
4	GND

6.6.4 MSM Connector Pinout Guide

Check the following connector pinout information applied to the connection ports of the MSM.

Power Connector

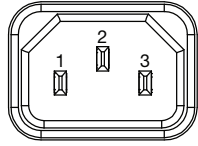

IEC 320 C14 Plug Male

Pin	Signal
1	LIVE
2	GND
3	NEUTRAL

Cable Connector

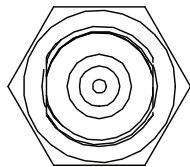

RF F Type Female

Conductor	Function
Inner	DATA
Outer	GND

6.6.5 Connecting Power to ACU

Connect the power cord from the power supply to the power connector (100-240 V AC) of ACU.



Figure 24: Connecting Power to ACU

6.6.6 Connecting ACU to ADU

Connect an **Antenna Cable (F to F)** (customer supplied) from the ANTENNA (F) port of the ACU to the Antenna RF (F) port of radome (antenna).

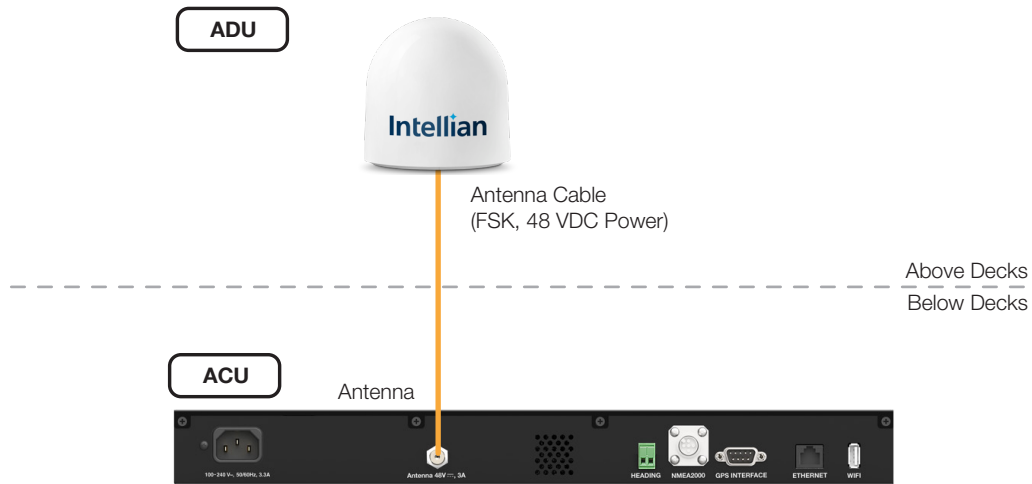

Figure 25: ACU to Antenna Cable Connection

6.6.7 Connecting ACU to Ship's Gyrocompass

For satellite tracking, connect a ship gyrocompass to the antenna system through the gyrocompass interface of the ACU. The Intellian ACU supports NMEA 0183 and NMEA 2000 gyrocompass inputs. If the gyrocompass has a different output standard, use a compass converter to supply the required NMEA input. The NMEA 2000 gyrocompass needs to be purchased separately. Refer to **"6.6.3 ACU Connector Pinout Guide" on page 41** for the pin configuration.

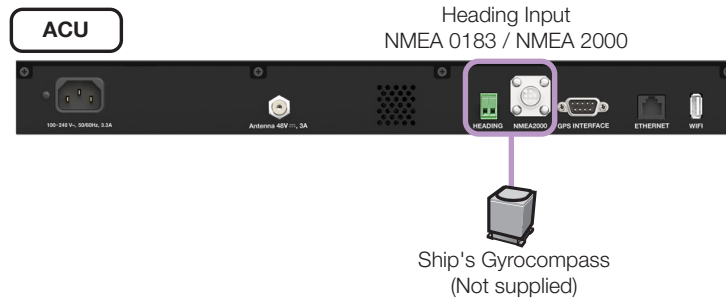
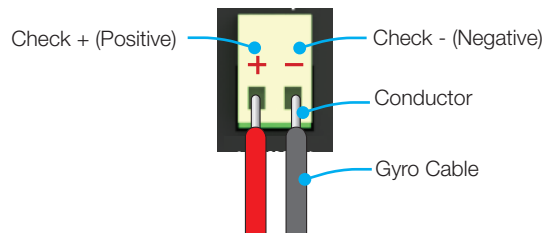

Figure 26: ACU to Ship's Gyrocompass Cable Connection

How to Connect NMEA 0183 Gyrocompass Cable

1. Using a flat head screwdriver, loosen the two screw terminals by rotating them counterclockwise.
2. Strip wires up to 5 mm (0.2"). Do not solder the cables.
3. Insert the conductor and gyro cable wires into the – (negative) and + (positive) terminals, respectively, of the terminal block. Check the polarity to make sure the wires are inserted correctly.



4. Fully tighten the terminal block screws by rotating them clockwise to clamp the wires securely.
5. Insert the terminal block with gyro cables to the NMEA 0183 (GYRO) port of ACU.

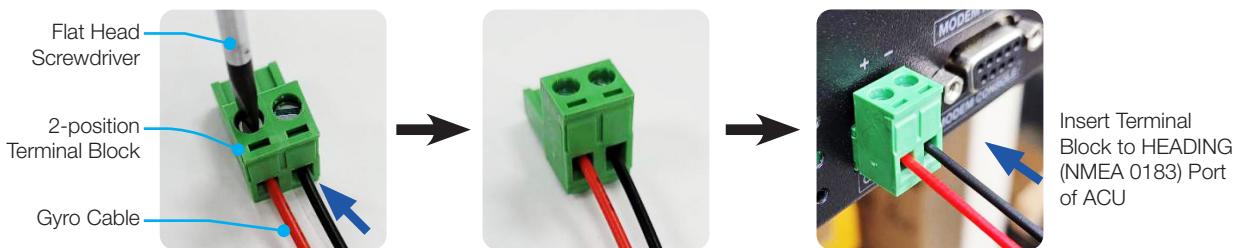

Figure 27: NMEA 0183 Gyrocompass Cable Connection

6.6.8 Connecting RF Cables (RF1-4) to the Multi-Switch Module

The Intellian s130N is capable of receiving multiband and multi-polarization satellite TV service around the globe using the Intellian WorldView™ Trio LNB module.

1. Connect the antenna cable from the ACU Antenna connector in the radome to the Antenna connector on the rear of the ACU.
2. Connect RF1 cable to the VL (13 V+0 KHz) port of the Multi-Switch Module.
3. Connect RF2 cable to the HL (18 V+0 KHz) port of the Multi-Switch Module.
4. Connect RF3 cable to the VH (13 V+22 KHz) port of the Multi-Switch Module.
5. Connect RF4 cable to the HH (18 V+22 KHz) port of the Multi-Switch Module.
6. Connect between Multi-Switch Module and receivers using RF cables.
(Up to 26 SWM compatible receivers and up to 8 non-SWM compatible receivers can be connected through the supplied Multi-Switch Module.)

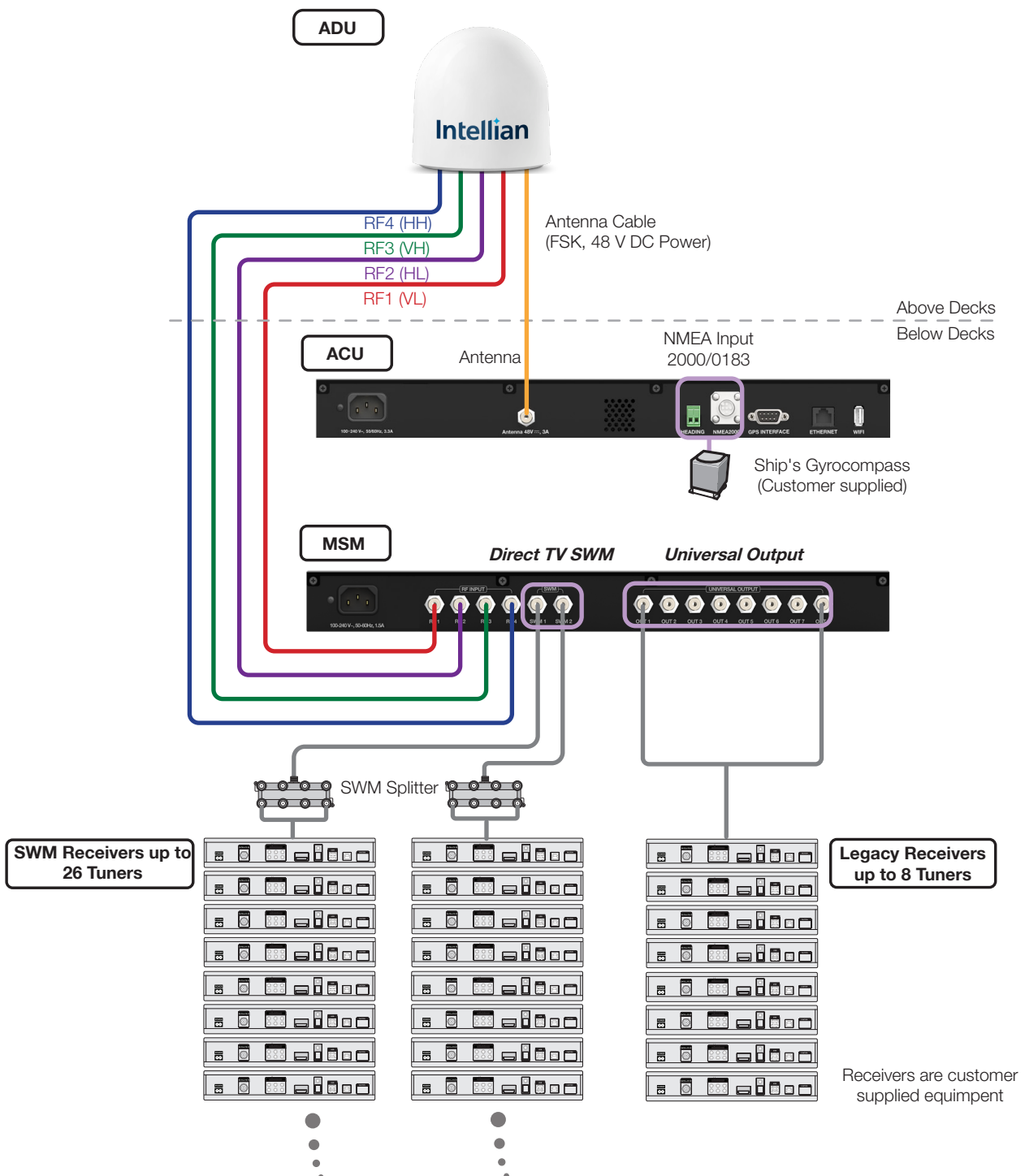

Figure 28: Multi-Switch Module Connection



NOTE

Intellian s130N system includes a multi-switch module.

Make sure the followings before installing system cables.

1. When you select a target satellite that is configured in single LNB mode (such as 10750 or 11250), the RF1 (VL) and RF2 (HL) have signals from the Worldview LNB module and each signal will be distributed from the RF1 (VL) port to the RF3 port and from the RF2 (HL) port to the RF4 port.

LNB Mode	RF1	RF2	RF3	RF4
Multi LNB Mode	13 V + 0 KHz	18 V + 0 KHz	13 V + 22 KHz	18 V + 22 KHz
	VL (Vertical Low)	HL (Horizontal Low)	VH (Vertical High)	HH (Horizontal High)
Single LNB Mode	13 V + 0 KHz	18 V + 0 KHz	*13 V + 0 KHz	**18 V + 0 KHz
	VL (Vertical Low)	HL (Horizontal Low)	*VL (Vertical Low)	**HL (Horizontal Low)

*:Distributed from the RF1 (VL) in the Single LNB Mode.

**Distributed from the RF2 (HL) in the Single LNB Mode.

2. The system must have the four inputs x multi outputs multi-switch unit. Do Not connect receivers to the RF1~RF4 cables directly.

6.7 ACU to PC Communication Setup

You can establish data communication between the Below Deck Unit (ACU) and a PC using a TCP/IP (Ethernet), USB, or Wi-Fi connection and a PC the using one of the following methods.

6.7.1 TCP/IP Connection

Connection through Front Panel Management Port

The network is automatically configured by DHCP with no additional PC IP configuration required.

1. Connect an Ethernet cable from the Management LAN port on the front of the ACU to the LAN port of PC. The network connection is established automatically.
2. Open a web browser (Chrome, Firefox, etc.), and then enter the following IP address to access the Intellian AptusNTV Login page.
 - **IP Address: 192.168.2.1 (Default)**

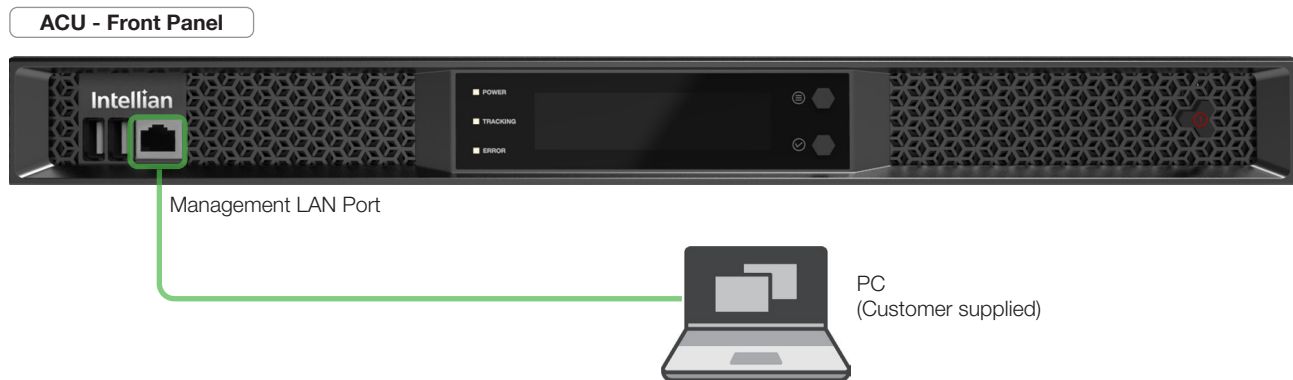

Figure 29: Front Panel Management LAN Port Connection

6.7.2 USB Connection

Using Right Side USB Port on ACU Front Panel

Connect a USB flash drive to the right side USB port on the front panel of ACU to download logs, backup/restore antenna settings, and upgrade firmware.



NOTE

- The left side USB port is a serial connection and for certified engineer use only.
- AptusNTV access and iARM upgrade are NOT supported through the serial USB connection.



Figure 30: Front Panel USB Port Connection

6.7.3 Wi-Fi Connection

Connection through Wi-Fi Dongle

Intellian provides the Wi-Fi Dongle for Wi-Fi connection to AptusNTV. You can connect a PC to the ACU via Wi-Fi for easy management and control whenever you are on the vessel.

1. Connect an Ethernet cable from the Management LAN port on the front panel of ACU to a LAN port of a PC. The network connection is established automatically.
2. Find the Wi-Fi Dongle in the ACU box, and then insert the Wi-Fi Dongle into the USB port on the back panel of ACU.



Figure 31: Rear Panel Wi-Fi Dongle Connection

3. Open a web browser, and then enter the following IP address to access Intellian AptusNTV page.
 - **IP Address: 192.168.2.1 (Default)**
4. Log in to AptusNTV by typing the User Name and Password. If the system has not been changed from the factory default:
 - **User Name: intellian**
 - **Password: intellian1@1**
5. Select **Setup** on the main menu, and then select the **Wi-Fi** menu.
6. Choose **Enable** for the **Activate** option to edit the configuration.
7. Note the **SSID** (Wi-Fi Access point/network name) information.
8. Choose **Enable** for the **SSID Broadcast** option to show the **SSID** (Wi-Fi Access point/network name) information.
9. Click the **Apply** button to apply the settings to the system. Then perform "**9.7.5 Wi-Fi**" on page 90.
10. After a reboot, you can connect to the Wi-Fi with any network enabled device.

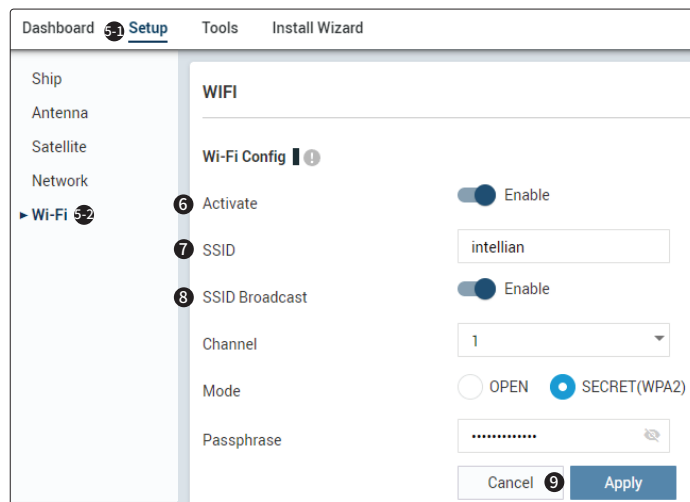

Chapter 7. Operating Install Wizard

7.1 Turning On System

Make sure the antenna has a clear view of the sky. Press the **POWER** button on the front panel of the Below Deck Unit (ACU), and then wait a few minutes for system startup. Once the antenna finds the satellite, the **TRACKING** indicator light on the ACU display will turn green.

7.2 Accessing AptusNTV

1. Connect an Ethernet cable from the Management LAN port on the front of the ACU to the LAN port of a PC. The network connection is established automatically.
2. Open a web browser (Chrome, Firefox, etc.), and then enter the following IP address to access the Intellian AptusNTV Login page.
 - **IP Address: 192.168.2.1 (Default)**
3. Log in to AptusNTV by entering the User ID and Password.
 - **User ID: intellian (Default)**
 - **Password: intellian1@1 (Default)**



Figure 32: Front Panel Management LAN Port Connection

7.3 Starting Install Wizard

The Install Wizard will give you a guide by going through the steps of setup for the antenna system commissioning. We highly recommend using this wizard to complete the installation and commissioning of the system. You can exit the wizard at any time. You can also skip steps by clicking the > (Next) button. Before you start, make sure the basic devices (antenna, gyrocompass, etc.) are connected to the ACU properly. After accessing the AptusNTV main page, go to the **Install Wizard** on the main menu then follow these steps.

✓ Welcome Page

Welcome message is displayed. Click the > (Next) button to go to the next step.

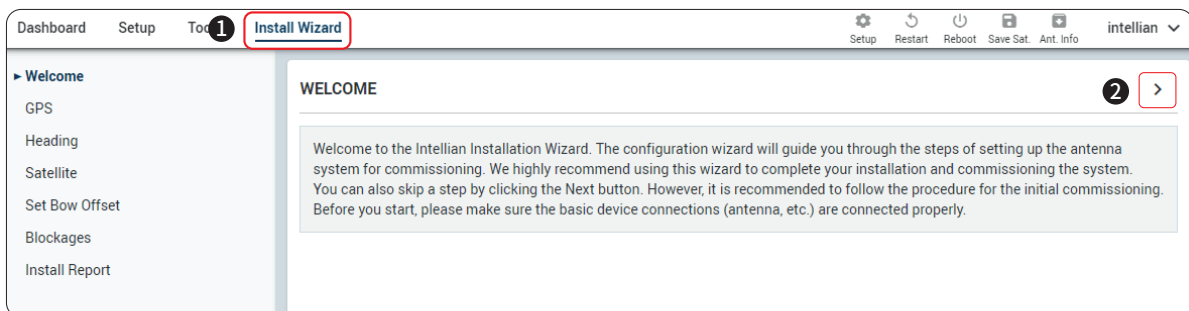

✓ Step 1: GPS

In this step you check the status of the GPS connected to the antenna system and, if necessary, set the GPS position of the antenna for satellite searching.

- GPS indicator: The colored indicator next to the title shows the GPS status. Make sure the GPS indicator is Blue.
 - Blue: The system received a correct GPS signal.
 - Black: The system has not received any GPS signal. You can enter the GPS value manually to set the GPS position.
- Longitude (°): Set Longitude information (East / West).
- Latitude (°): Set Latitude information (North / South).

Click the **Apply** button to apply the settings to the system and the > (Next) button to go to the next step.

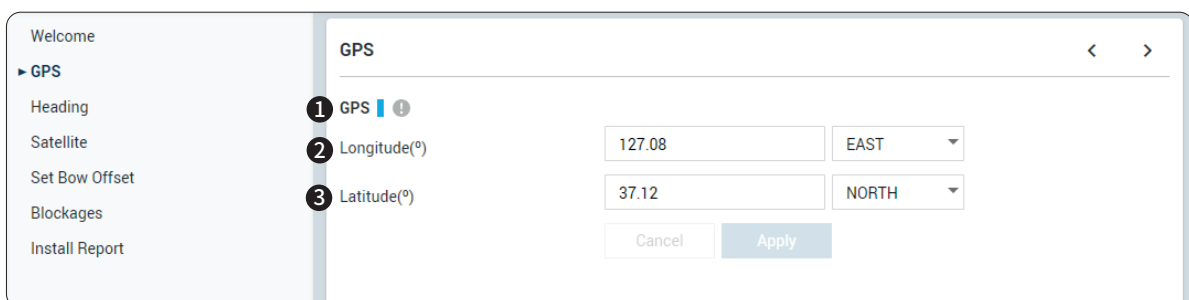

✓ **Step 2: Heading**

Set the Heading Device to NMEA.

- **Heading Device:** The colored indicator next to the title shows the heading device connection status.
 - Blue: Ship's heading device is connected.
 - Black: Ship's heading device is not connected.
- **Current Device:** Select NMEA from the drop-down list, and then click the Apply button to apply the Heading Device setting to the system. Other heading device options include None, NMEA2000 and Static.
- **Heading (°):** Displays the current heading angle from the ship's gyrocompass. To manually set the heading value, enter the value in the box, then click the Apply button. Note, however, that the value will be updated with the actual heading value immediately.
-

Click the > (Next) button to go to the next step.

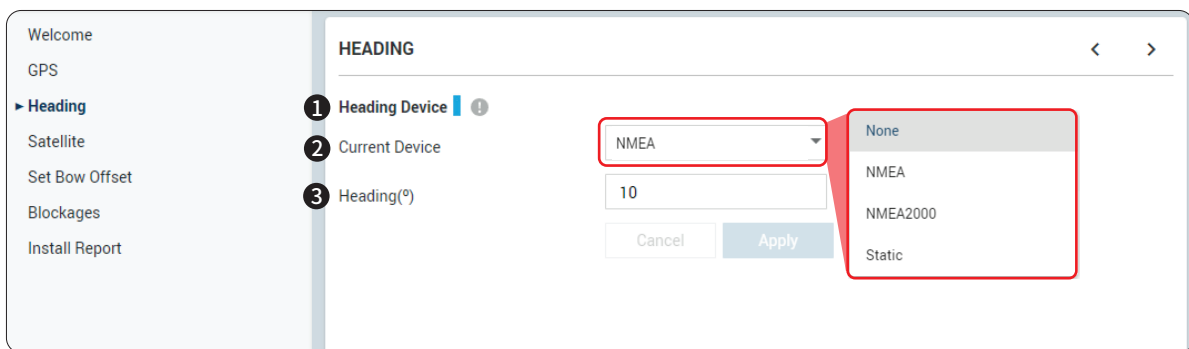

✓ Step 3: Satellite

Display, track, and edit the satellites in the satellite set. For more information about using the Satellite Set, refer to "9.7.3 Satellite Set" on page 88.

- Satellite Set: Displays the five satellites in the current satellite set. The tracked satellite has a green Active icon. Track another satellite in the set by clicking its gray Inactive icon.
- Load from Preset: Displays the Select From Library window with all the satellite sets from the preset library.
- Set: In the Select From Library window, click the Set button for the satellite set you want loaded into the Satellite Set window.

Click the > (Next) button to go to the next step.

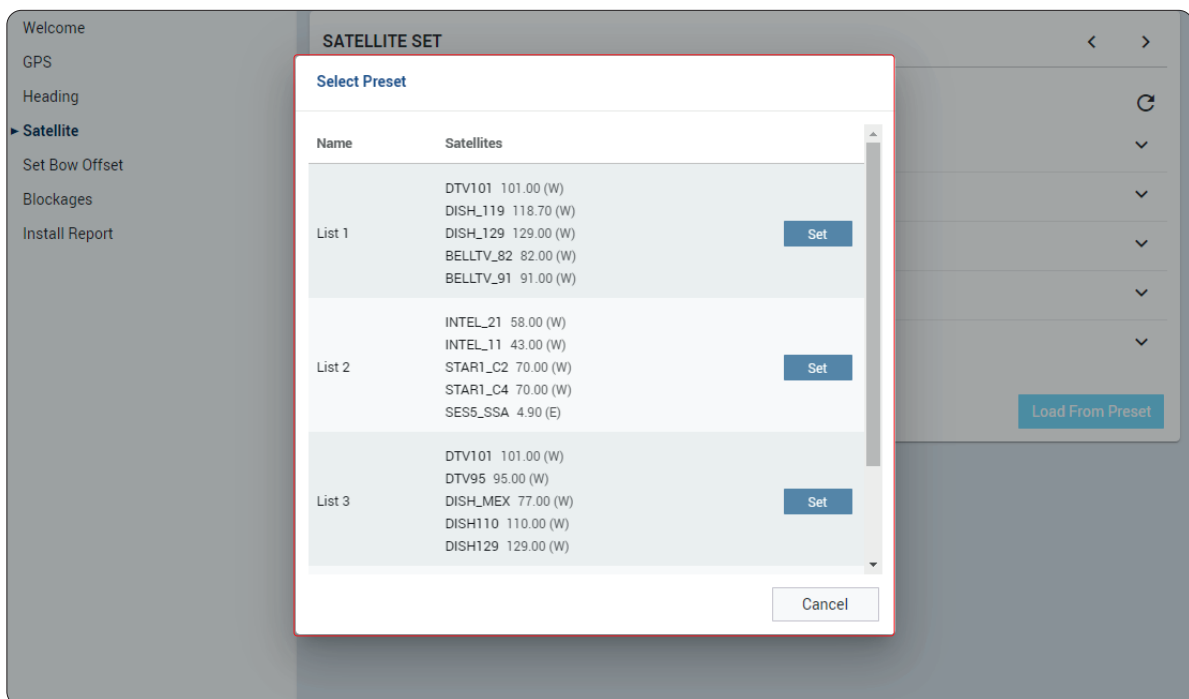
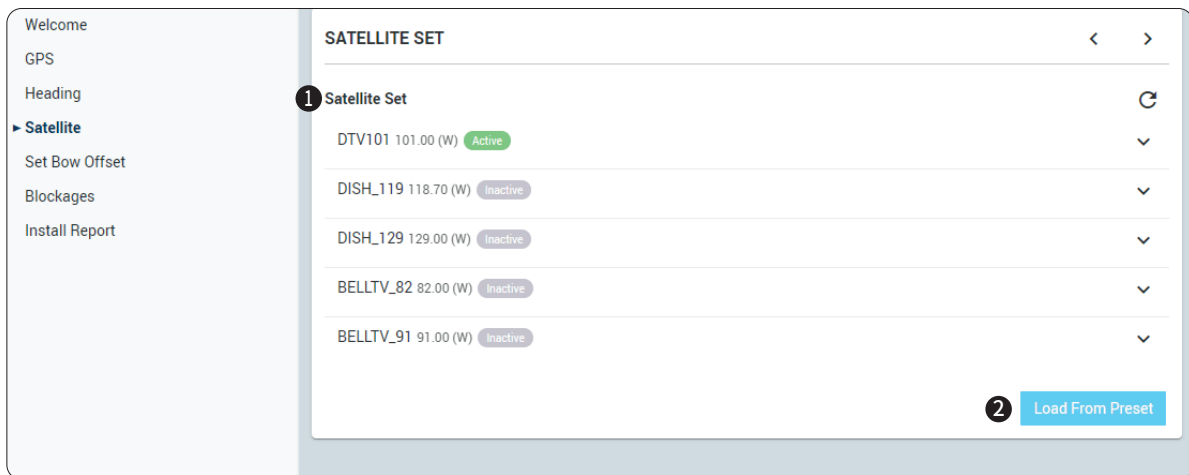

✓ **Step 4: Set Bow Offset**

Set the bow offset by tracking a satellite with a strong signal. First make sure you have selected a satellite with a strong signal on the previous step, Satellite Set.

- **Search:** Click the Start Searching button to detect the bow offset based on the location of the currently tracked satellite.
- **Set Bow Offset:** Sets the Bow Offset automatically when antenna is tracking a satellite. When the Current Bow Offset displays and the Lock icon turns green, the bow offset is set.

First, select the satellite from the library and update the satellite information. Then, click the Start Searching button.

Make sure the Lock icon turns green, and then click the Save satellite button.

Click > (Next) button to go to the next step.

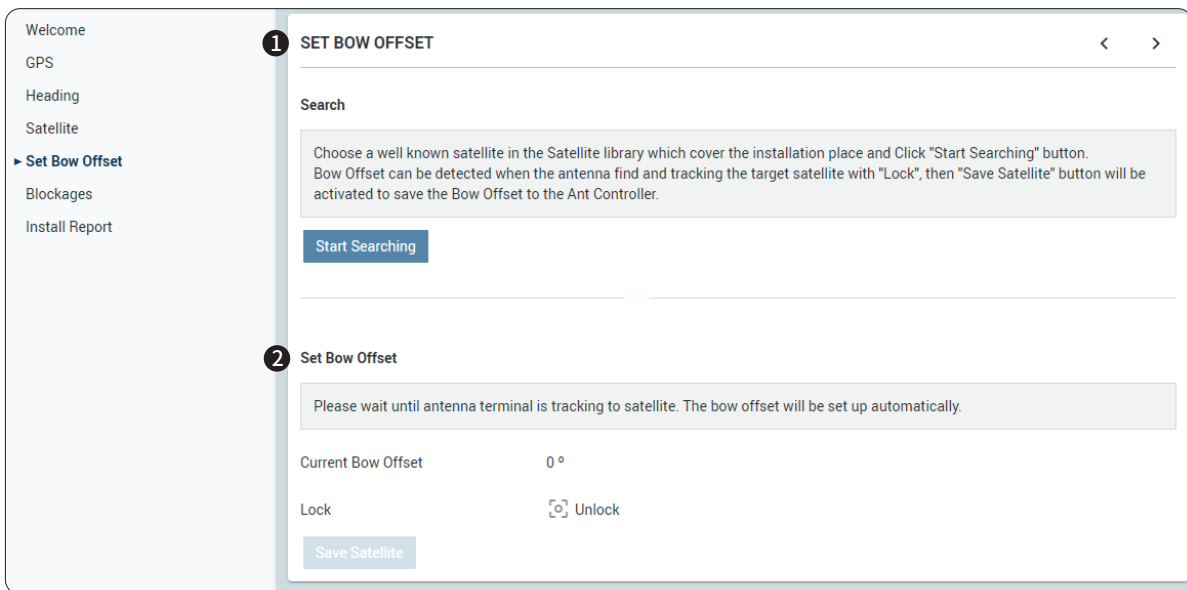

✓ **Step 5: Blockage**

Up to five antenna blockage zones can be set by entering the relative azimuth and elevation sectors where line of site will be blocked. Setting blockage zones ensures that the programs viewers watch won't be interrupted by keeping the antenna from pointing to those zones.

The **Az. Start** is the relative azimuth angle where the blockage starts, and the **Az. End** is the relative azimuth where the blockage ends (Range: 0 ~ 360). The **EI.** is the elevation angle where the blockage is set (Range: 0 ~ 90). The blockage is activated below the set elevation angle.

Click the **Apply** button to apply the settings to the system and the > (Next) button to go to the next step.

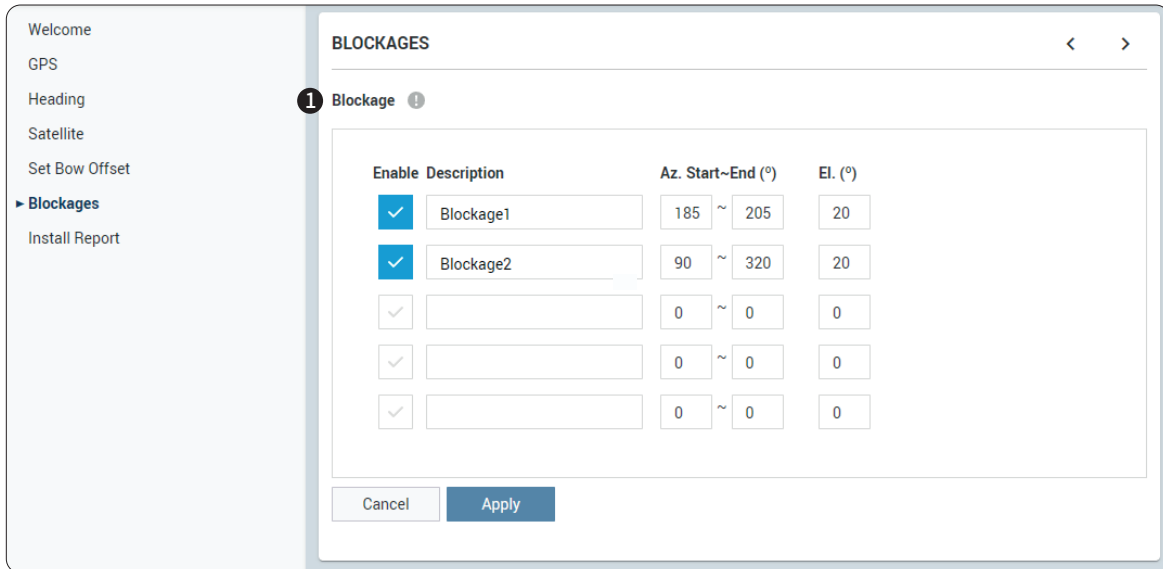

✓ **Step 6: Install Report**

The configuration install report is displayed. If you enter a Name, Company, ID, and e-mail, they will be saved with the report.

- Save: Save the results to your PC.
- Export: Download the report file (.json) to the PC or print the report to your system printer.
- View Last Report: Display a window containing the most recently saved report information, including the date and time saved.

This completes the steps of the wizard.

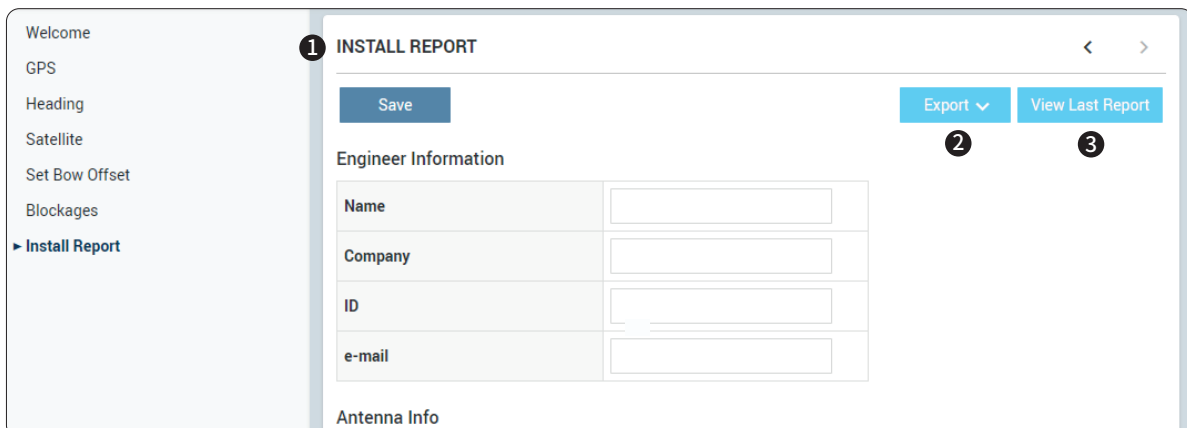

Chapter 8. Operating ACU

8.1 Introduction

8.1.1 ACU Front Panel View

The following figure shows the front panel the ACU.

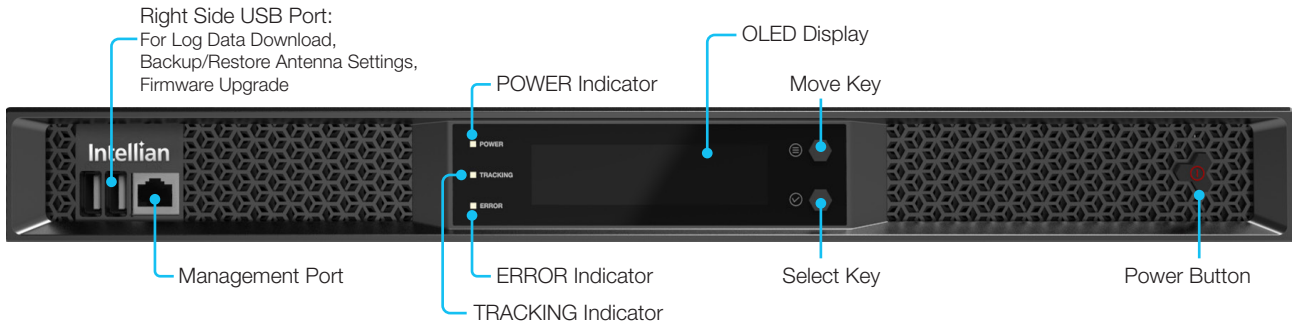

Figure 33: ACU Front Panel View

The following table describes the function of each touch key.

Touch key	Function
Power Button	Powers on/off the System (ACU and ADU).
Move Key	Moves to the desired screen/menu.
Select Key	Selects the desired screen/menu.

The following table describes status indicators on the face of ACU.

LED Display	Color	Description
POWER	Steady Green	The ACU is powered on.
	Off	The ACU is powered off.
TRACKING	Steady Green	The antenna is in tracking mode.
ERROR	Steady Red	The antenna is in an error status.

8.1.2 ACU Display Menu

The following figure shows the ACU display menu.

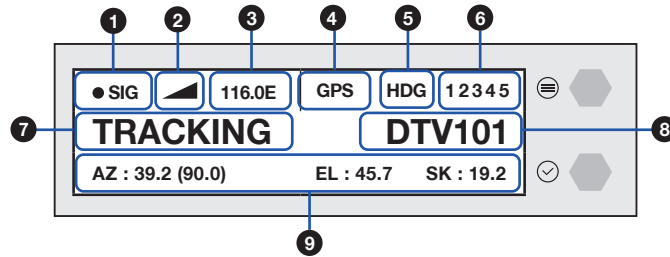

The following table describes the function of each touch key.

No.	Item	Description
①	Satellite Lock	Displays the satellite lock status.
②	Signal Level	Displays the antenna signal level.
③	Target Satellite	Displays the target satellite longitude (E: East, W: West).
④	GPS Lock Status	Displays the GPS lock status.
⑤	Heading Information	Displays heading information (e.g., gyrocompass).
⑥	Active Target Satellite	Displays the active target satellite from among the current satellite set.
⑦	Antenna Status	Displays the antenna status (TRACKING, SEARCH 1, SEARCH 3, BLOCKING).
⑧	Target Satellite Name	Displays the target satellite name.
⑨	Satellite Position	Displays the satellite position using AZ (azimuth), EL (elevation angle), and SK (skew).

8.2 Startup

With the system is installed and power is applied, the ACU display will show the following sequence.

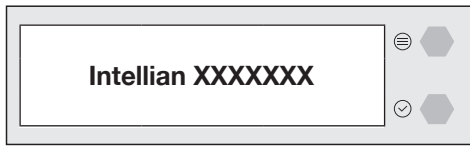

✓ **Startup**

Intellian's model name is displayed.

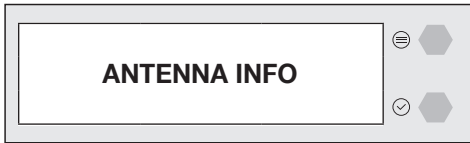

✓ **Initialize Antenna Information**

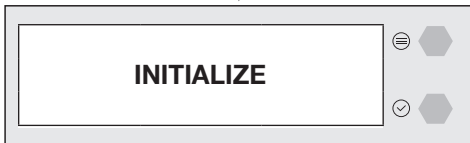

✓ **Initialize Elevation Angle or Azimuth Angle**

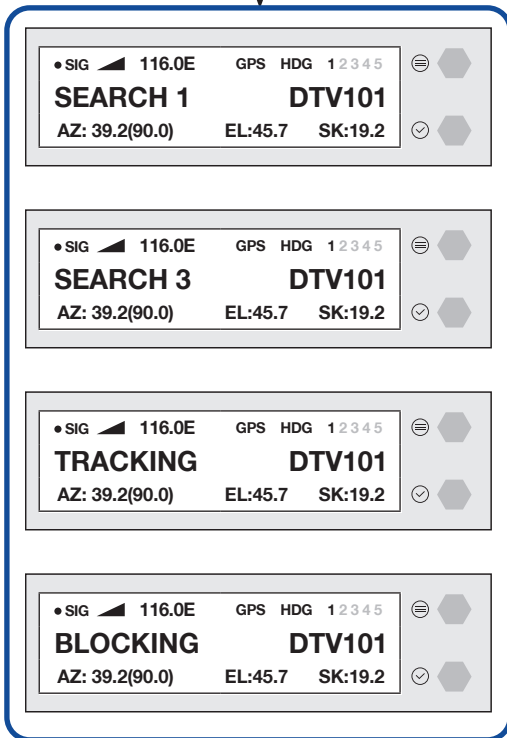

✓ **Antenna's Status**

SEARCH 1 (Global Search), SEARCH 3 (Local Search), TRACKING, BLOCKING

When the antenna is controlled by Aptus NTV, the ACU displays the control mode status.

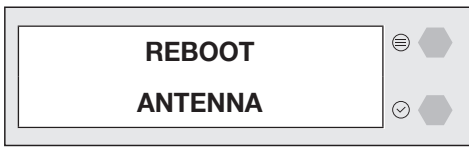

✓ **Control Mode Status**
 (Displays REBOOT ANTENNA mode or SETUP MODE)

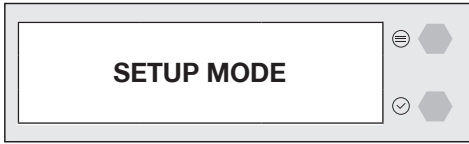

If the antenna does not communicate with ACU, the **COMMUNICATION ERROR** is displayed.

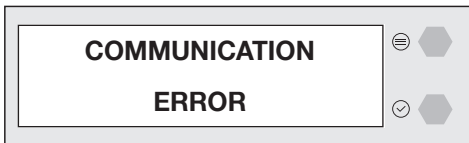

8.3 Satellite Information

Displays the currently registered list of the satellite.



Press
Move Key

✓ **Main Display**

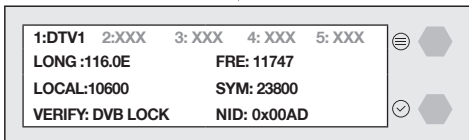

✓ **Satellite Information Display**

Selecting other satellites information



✓ Main Display

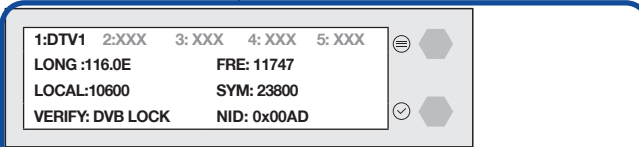

✓ Satellite Information Display

Select the satellite from among the satellite set.

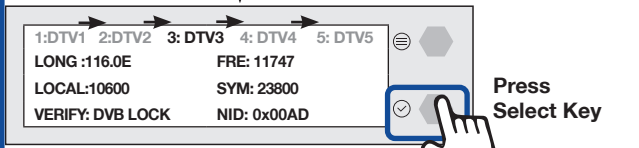

Confirm the selected satellite.

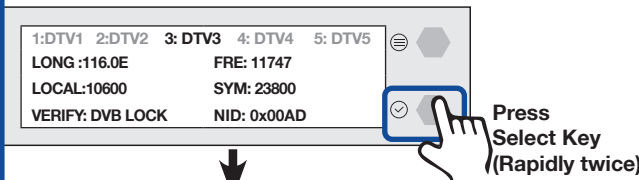

✓ Main Display

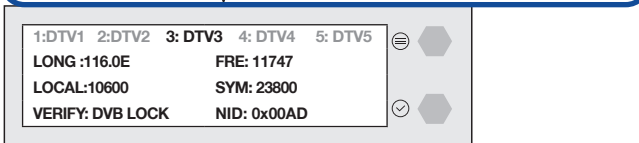

✓ Satellite Information Display

Refer to the Satellite Information display.

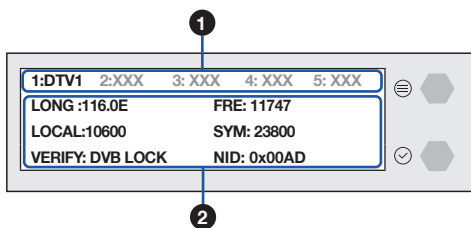

No.	Item	Description
①	Satellite List	Displays the registered satellite list (The target satellite name is displayed bright white, while the other four satellites in the set are dimmed.).
②	Satellite Information	Displays the satellite information (Longitude, Frequency, Local, Verify, etc.)

8.4 Interface Information

Displays the GPS/heading type in use and the connection status.

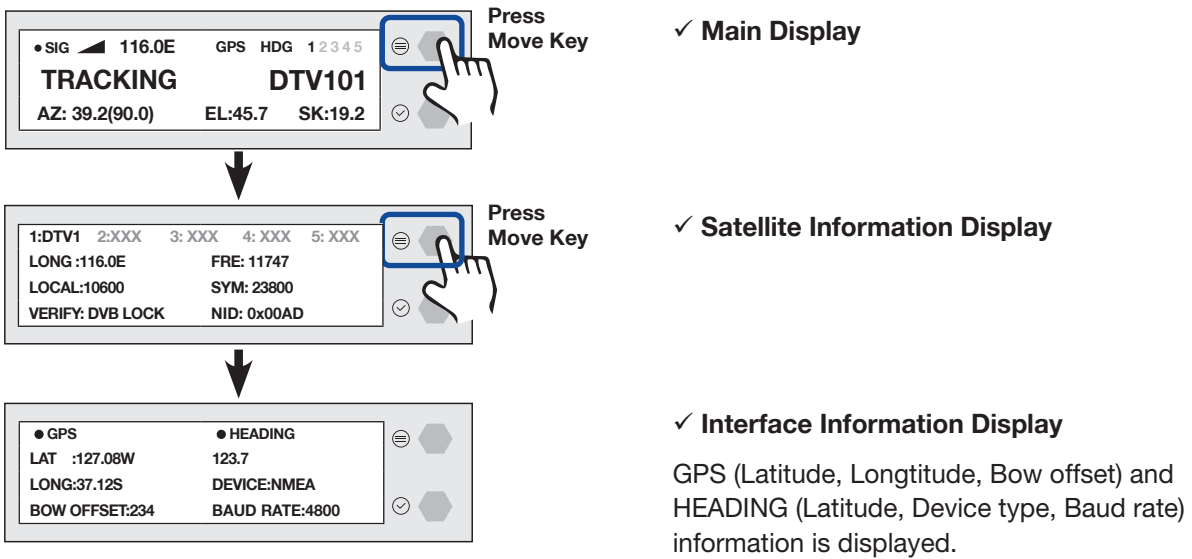

Refer to the Interface Information display.

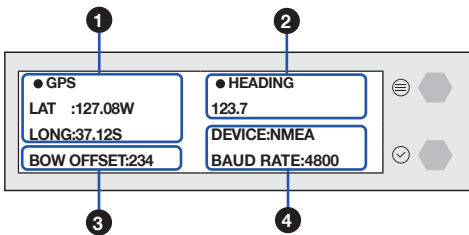

No.	Item	Description
①	GPS Status/Data	Displays GPS status (displayed white if receiving, dimmed if not) and GPS data (Latitude and Longitude).
②	HEADING Status/Data	Displays heading status and data.
③	Bow Offset	Displays bow offset
④	Heading Device	Displays the heading type in use (NONE, NMEA, STATIC) and BAUD rate. NOTE: Baud rate will be displayed for NMEA Only.

8.5 Antenna Information

Displays antenna serial number, ACU serial number, firmware version, and ACU software version of the system.

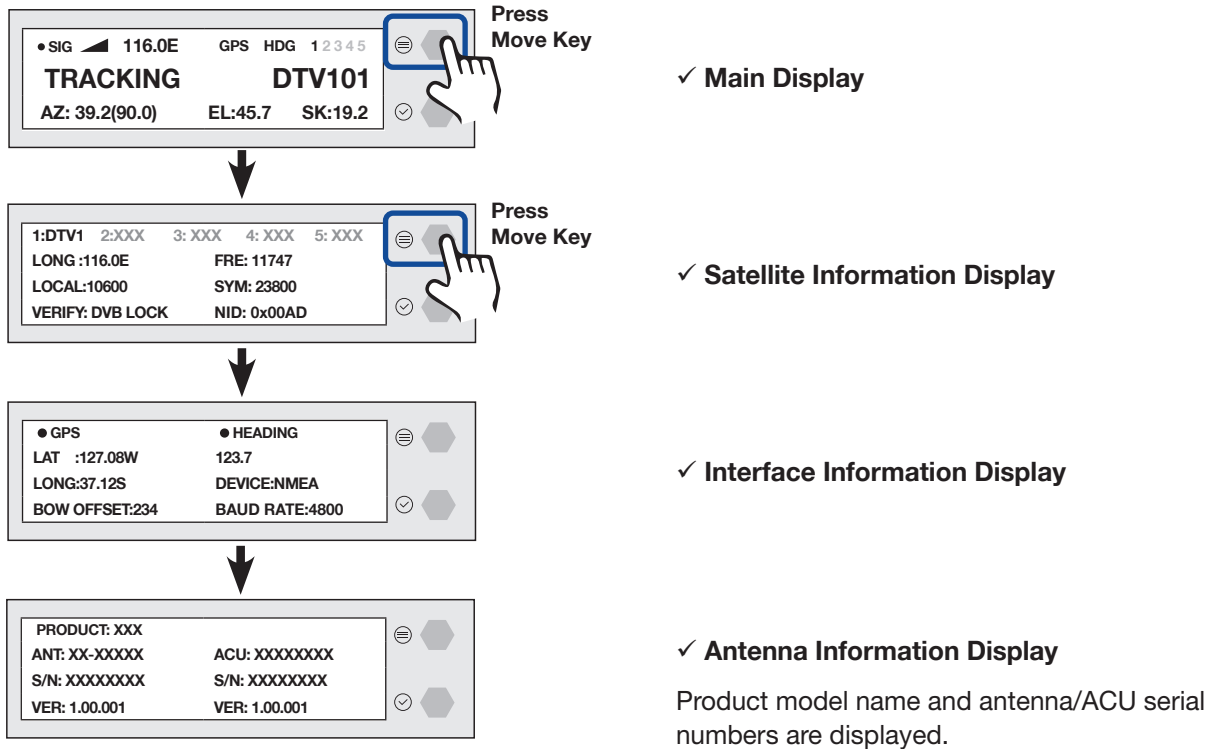

Refer to the Antenna Information.

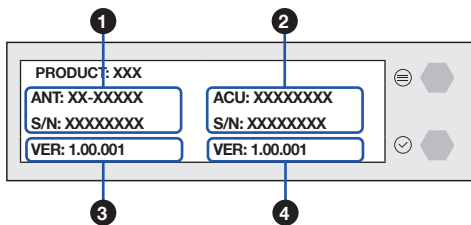

No.	Item	Description
①	Antenna Serial Number	Displays the Antenna serial number. The serial number is displayed depending on the product.
②	ACU Serial Number	Displays the ACU serial number. The serial number is displayed depending on the product.
③	F/W Version	Displays the Firmware version.
④	ACU Version	Displays the Software version.

8.6 Diagnosis

Executes antenna Diagnosis tests and shows the real-time diagnostic results.



✓ Main Display

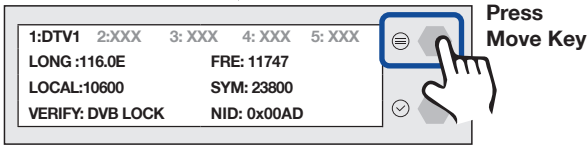

✓ Satellite Information Display

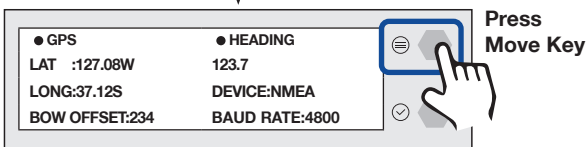

✓ Interface Information Display

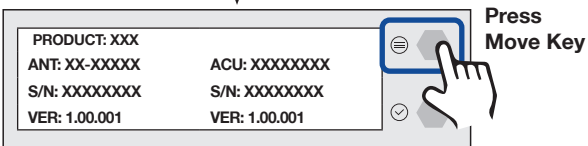

✓ Antenna Information Display

Product model name and antenna/ACU serial numbers are displayed.

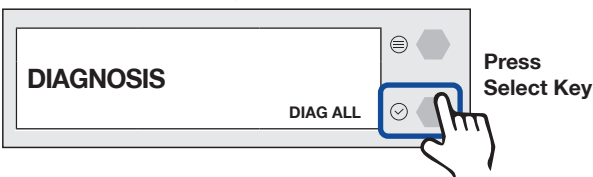

✓ Diagnosis Display

Press the Select key to run the diagnostics.

Refer to the diagnosis codes for the test results.

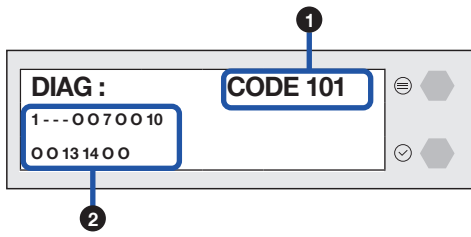

No.	Item	Description																																		
①	Diagnosis Code	<p>Displays the diagnosis code for the test that is currently running. When all tests are complete, DONE is displayed.</p> <table border="1"> <thead> <tr> <th>Code</th> <th>Test</th> </tr> </thead> <tbody> <tr> <td>101</td> <td>The data communication between the antenna and the ACU is tested.</td> </tr> <tr> <td>102</td> <td>The azimuth axis is tested.</td> </tr> <tr> <td>103</td> <td>The elevation axis is tested.</td> </tr> <tr> <td>104</td> <td>The cross-level axis is tested.</td> </tr> <tr> <td>105</td> <td>Not Available</td> </tr> <tr> <td>106</td> <td>Not Available</td> </tr> <tr> <td>107</td> <td>The rate sensor is tested.</td> </tr> <tr> <td>108</td> <td>Not Available</td> </tr> <tr> <td>109</td> <td>Not Available</td> </tr> <tr> <td>110</td> <td>The LNB / NBD is tested.</td> </tr> <tr> <td>111</td> <td>Not Available</td> </tr> <tr> <td>112</td> <td>Not Available</td> </tr> <tr> <td>113</td> <td>The antenna power is tested.</td> </tr> <tr> <td>114</td> <td>The ACU power is tested.</td> </tr> <tr> <td>115</td> <td>Not Available</td> </tr> <tr> <td>116</td> <td>The home sensor is tested.</td> </tr> </tbody> </table>	Code	Test	101	The data communication between the antenna and the ACU is tested.	102	The azimuth axis is tested.	103	The elevation axis is tested.	104	The cross-level axis is tested.	105	Not Available	106	Not Available	107	The rate sensor is tested.	108	Not Available	109	Not Available	110	The LNB / NBD is tested.	111	Not Available	112	Not Available	113	The antenna power is tested.	114	The ACU power is tested.	115	Not Available	116	The home sensor is tested.
Code	Test																																			
101	The data communication between the antenna and the ACU is tested.																																			
102	The azimuth axis is tested.																																			
103	The elevation axis is tested.																																			
104	The cross-level axis is tested.																																			
105	Not Available																																			
106	Not Available																																			
107	The rate sensor is tested.																																			
108	Not Available																																			
109	Not Available																																			
110	The LNB / NBD is tested.																																			
111	Not Available																																			
112	Not Available																																			
113	The antenna power is tested.																																			
114	The ACU power is tested.																																			
115	Not Available																																			
116	The home sensor is tested.																																			
②	Diagnosis Result	<ul style="list-style-type: none"> Below is an example of a diagnosis result: <table border="1"> <tbody> <tr> <td>1---0070010</td> <td>← Diagnosis Result of Code 101-110</td> </tr> <tr> <td>00131400</td> <td>← Diagnosis Result of Code 111-116</td> </tr> </tbody> </table> <p>Each place in the results corresponds to the last one (codes 101 through 109) or two (codes 110 through 116) digits of a diagnosis code.</p> <ul style="list-style-type: none"> - If a dash (-) is displayed, the system passed the test. In the above example, the system passed the tests for codes 102, 103, and 104. - If the last 1 or 2 digits of a diagnosis code are displayed, the system failed the test. In the above example, the system failed the tests for codes 101, 107, 110, 113, and 114. - If O is displayed, the test was not performed. In the above example, the tests for codes 105, 106, 108, 109, 111, 112, 115 and 116 were not performed. 	1---0070010	← Diagnosis Result of Code 101-110	00131400	← Diagnosis Result of Code 111-116																														
1---0070010	← Diagnosis Result of Code 101-110																																			
00131400	← Diagnosis Result of Code 111-116																																			

8.7 USB Function

To use this function, insert a USB flash drive into the right side USB port on the front of the ACU. The USB Function includes four menus (LOG DOWNLOAD, FIRMWARE UPLOAD, BACKUP TO USB, RESTORE FROM USB). Follow the sequence below to access the USB functions. For detailed information about each function, refer to the following subsections.



NOTE

The USB function is activated only when a flash drive is detected in the front panel USB port (right side).



✓ Main Display

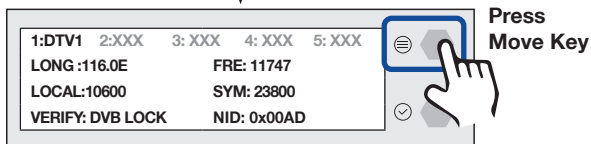

✓ Satellite Information Display

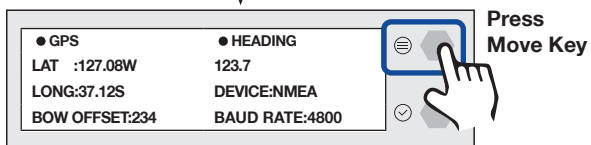

✓ Interface Information Display

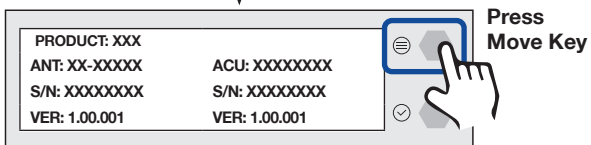

✓ Antenna Information Display

Product model name and antenna/ACU serial numbers are displayed.

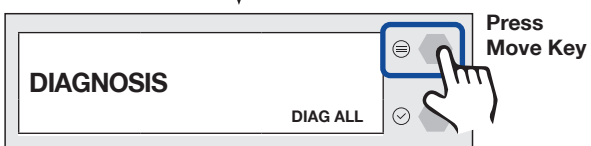

✓ Diagnosis Display



✓ USB Function Display

The USB function is activated only when a flash drive is detected in the front panel USB port (right side).



✓ USB Function Menu Display

8.7.1 Log Download

Downloads all data logs to the USB flash drive.

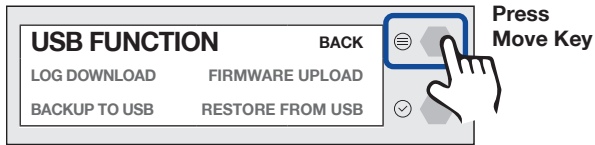

✓ **USB Function Menu Display**

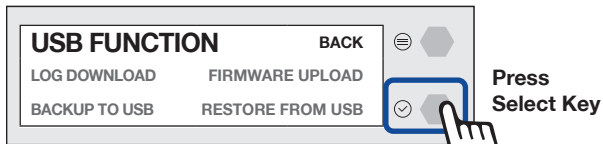

✓ **Log Download Menu Display**

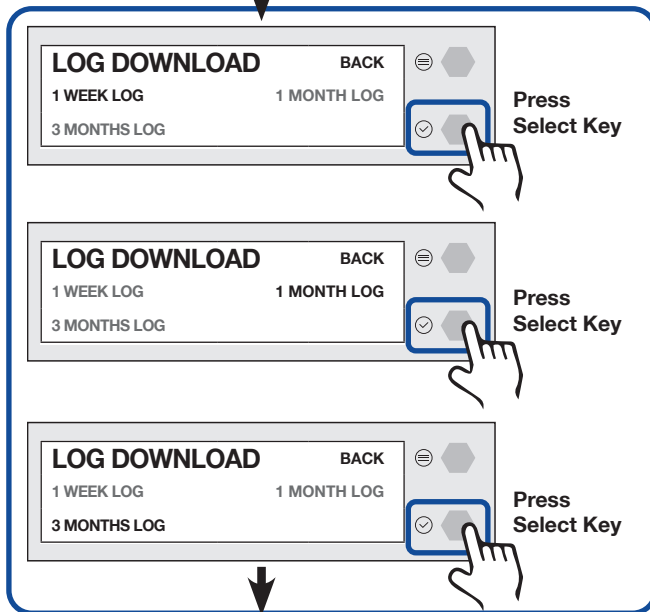

✓ **Download Log File to USB**

Select one of three options: 1 WEEK LOG, 1 MONTH LOG or 3 MONTHS LOG.

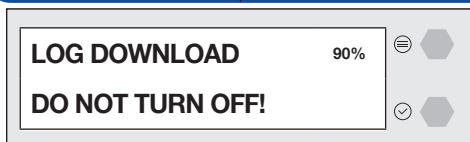

✓ **Download Process Display**

If there is not enough free space on the USB drive, the **NOT ENOUGH SPACE** message is displayed.

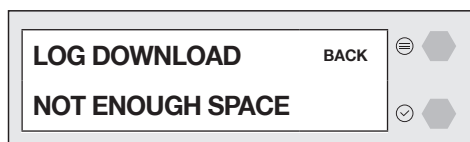

NOTE

If you want to go back to the previous screen, select the **BACK** option by pressing the **Select** key.

8.7.2 Firmware Upload

To use the Firmware Upload function, you must use the exact folder structure in the figure below. The function supports FAT32 or older formatted drives. You upgrade the antenna system by copying the FWP file to the /intellian/s130N/firmware folder on a USB flash drive. You also must rename the FWP file to CTR_T4.fwp.



NOTE

The FWP file name must be renamed to CTR_T4.fwp.

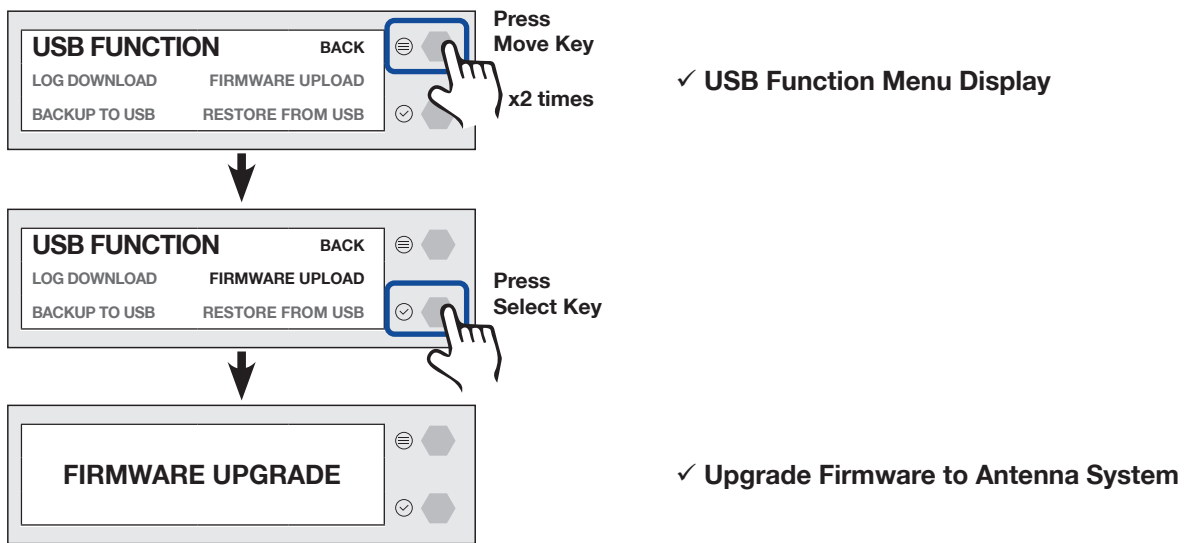

If the firmware file in USB is in invalid format, the **INVALID FILE FORMAT** message is displayed.

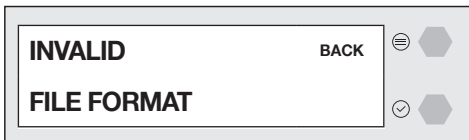

If any firmware file is not on the USB drive with the correct name and in the correct file structure, the **FILE NOT FOUND** message is displayed.

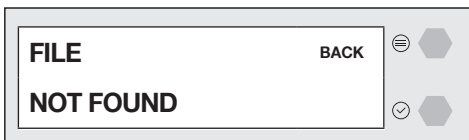

NOTE

If you want to go back to the previous screen, select the **BACK** option by pressing the **Select** key.

8.7.3 Backup to USB

Backs up the antenna setting files to the USB flash drive.

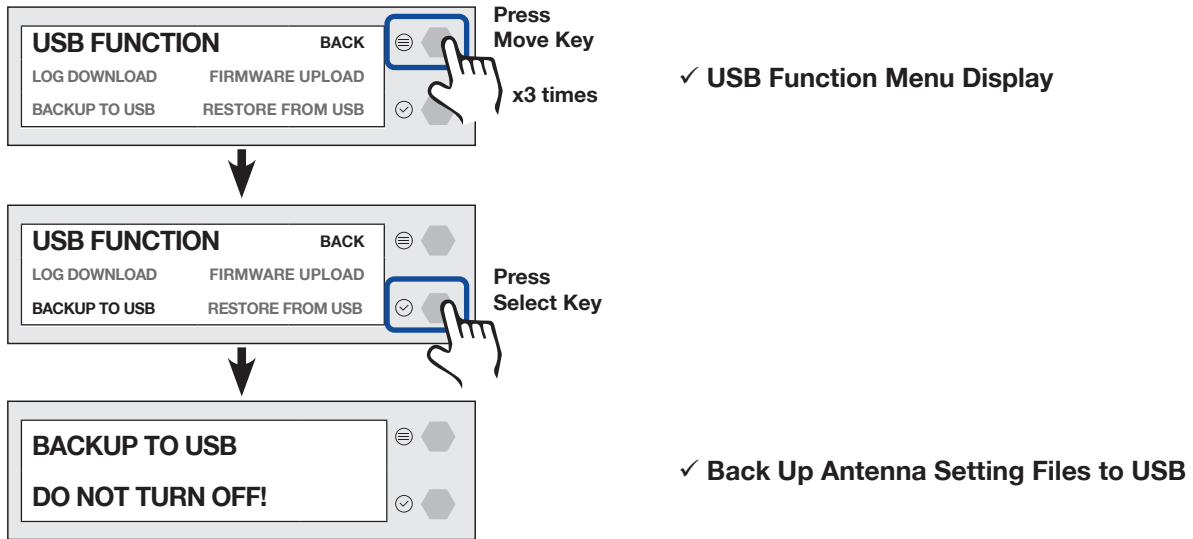

If there is not enough free space on the USB drive, the **NOT ENOUGH SPACE** message is displayed.

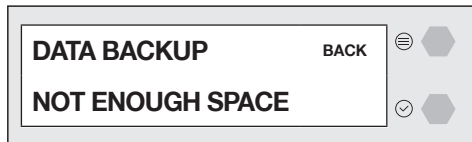

NOTE

If you want to go back to the previous screen, select the **BACK** option by pressing the **Select** key.

8.7.4 Restore From USB

Restores the antenna setting by using the setting files saved on the USB flash drive.

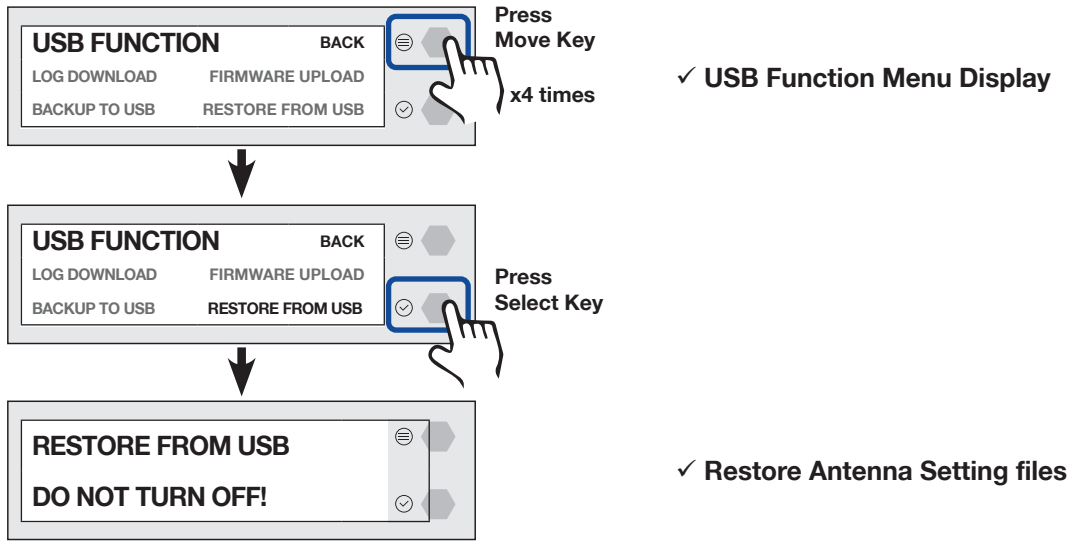

NOTE

If you want to go back to the previous screen, select the **BACK** option by pressing the **Select** key.

Chapter 9. Using AptusNTV

9.1 Introduction

With the embedded **AptusNTV** software, the antenna can be monitored, controlled, and diagnosed remotely from anywhere, anytime through TCP/IP protocol. This saves the time and cost generated by various maintenance activities, such as upgrading firmware, tracking parameter resets, and diagnosing system issues.

9.2 Accessing AptusNTV for ACU

This method is generally recommended.

1. Connect an Ethernet cable from the management LAN port on the front panel of the ACU to the LAN port on a PC.
2. Enter the ACU IP address (**Default: 192.168.2.1**) into the address bar of your web browser. The **AptusNTV** Login page displays.



NOTE

AptusNTV works on Internet Explorer 11 or higher (Windows 7 or higher editions), Firefox, Microsoft Edge and Chrome web browsers.

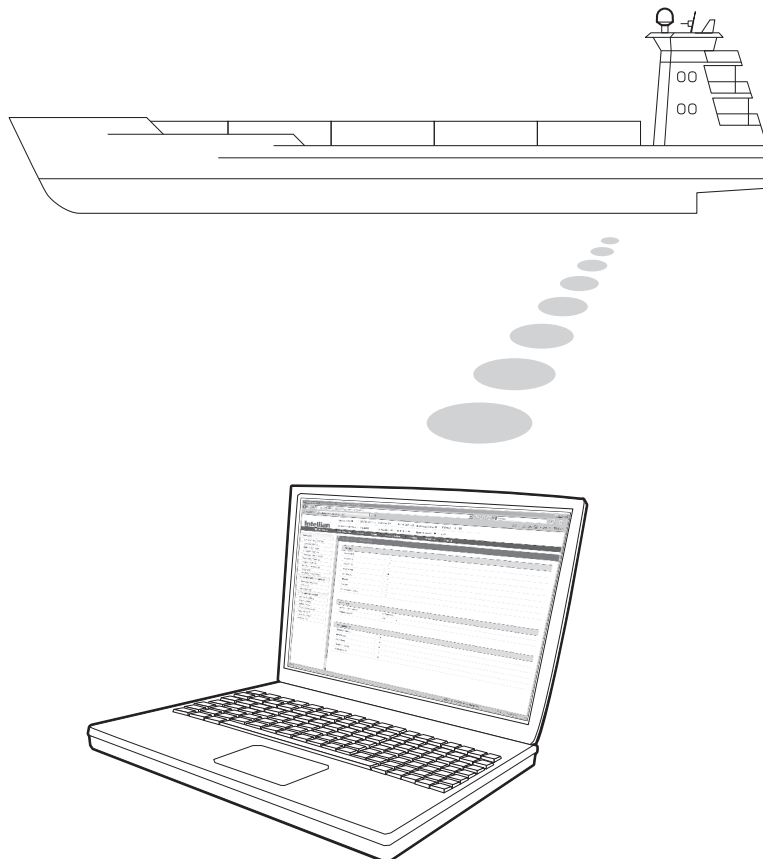

9.3 Main Page (Page Login)

The Intellian software Aptus provides different user access levels to protect the system for safe operation. The user level determines the accessible range of functions in the software (see the table below).

Log into the ACU by typing in a User ID and Password. The table below contains the factory default values.

User Type	User ID	Password	Access Authority
Admin	sysadmin	sysadmin1@1	All menus for monitoring and setting up the system, as well as account management
Operator	intellian	intellian1@1	All menus for monitoring and setting up the system, but limited menus for account management
User	guest	guest	Dashboard only

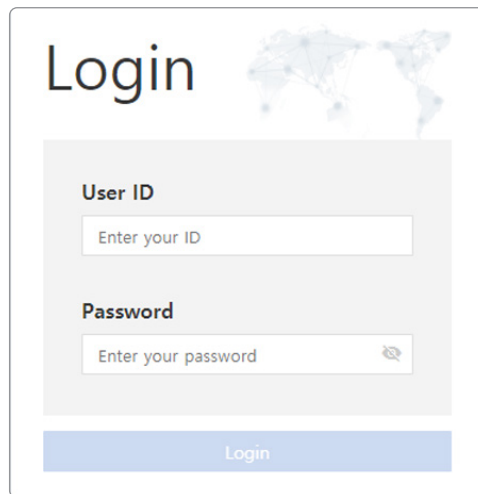

NOTE

You must change the default password to a new password for security. When you access the Aptus with a default password, the pop-up window for changing the password will appear. Click the Confirm button. The User Management page displays, where you can change the user password.

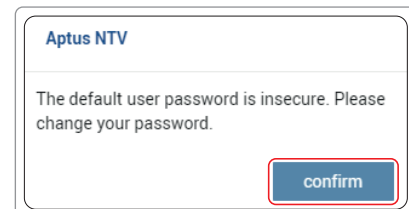

9.4 Top Menus

Once you log in, the following information and menus are displayed.



No.	Item	Description								
①	Target Satellite	Displays the the target satellite.								
②	Lock	<p>Displays the satellite lock status. If the lock icon is lit green, the antenna has locked on the satellite.</p> <table border="1"> <thead> <tr> <th>Icon</th> <th>Status</th> </tr> </thead> <tbody> <tr> <td></td> <td>Tracking</td> </tr> <tr> <td></td> <td>Both DVB lock and DVB/DSS decode with mismatched NID</td> </tr> <tr> <td></td> <td>Both DVB lock and DVB/DSS decode with NID matching</td> </tr> </tbody> </table> <p>NOTE Lock information can be checked by moving the mouse pointer over the Lock icon.</p>	Icon	Status		Tracking		Both DVB lock and DVB/DSS decode with mismatched NID		Both DVB lock and DVB/DSS decode with NID matching
Icon	Status									
	Tracking									
	Both DVB lock and DVB/DSS decode with mismatched NID									
	Both DVB lock and DVB/DSS decode with NID matching									
③	Signal Level	Displays the current signal level using a yellow bar indicator. The length of the bar increases with signal strength.								
④	Antenna Status Info	<p>Displays the antenna status/mode.</p> <ul style="list-style-type: none"> Initialize: The antenna system is initializing. Searching: The antenna is searching for the target satellite. Tracking: The antenna is tracking the target satellite. Setup: The antenna is in setup mode. Diagnostic: The antenna is in dianostic mode. Idle: The antenna is idle mode. Communication Error: AptusNTV is unable to communicate with the ACU. 								
⑤	Main Menu	Select a main menu item (Dashboard, Setup, Tools, Install Wizard). Each main menu item displays side menus on the left of the screen.								
⑥	Setup	Enters the setup mode to modify settings.								
⑦	Restart	Exits the Setup mode and switches to the normal mode (Searching/Tracking mode).								
⑧	Reboot	Powers off and restarts the antenna system. After system initialization, the antenna switches to normal mode (Searching/Tracking mode).								
⑨	Save Sat.	Adjusts and saves bow offset automatically. NOTE: Save Sat Button working at Search 3 conditions								
⑩	Ant. Info	Obtains current antenna information.								
⑪	Account Button	Click the button to manage the user account The Account, User Management , and System Information menus are for the user management. Click the Logout button to log out of the AptusNTV web page.								

9.5 Account Menu

1. Click the User ID to manage the user account.
2. Select **Account**, **User Management**, **System Information** or **Support** for user management. Select **Logout** to log out of *AptusNTV*.



9.5.1 Account

The screenshot shows the 'Account' settings page. On the left is a sidebar with 'Account' selected. The main area is titled 'USER'. Under '2 User Password Change', there is an 'ID' field with the value 'intellian', an 'Old Password' field, and a 'New Password' field, both with eye icons. An 'Apply' button is below. Under '3 Session Timeout Change', there is a 'Session Time' field with '60' and 'min' units, and an 'Apply' button.

No.	Item	Description
①	Account	Updates your password and sets time-outs.
②	User Password Change	<p>You can change your Password.</p> <ul style="list-style-type: none"> • ID: Displays your user ID. • Old Password: Enter the current password. • New Password: Enter the new password. <ul style="list-style-type: none"> - 8-32 Characters - A mixture of letters, speacial characters and numbers. - Inclusion of at least one letter, one numner and one special character. <p>Click the Apply button to apply the settings to the system.</p>
③	Session Timeout Change	<p>Enter the value in minutes (60 is default) for setting the session timeout.</p> <p>Click the Apply button to apply the settings to the system.</p>

9.5.2 User Management

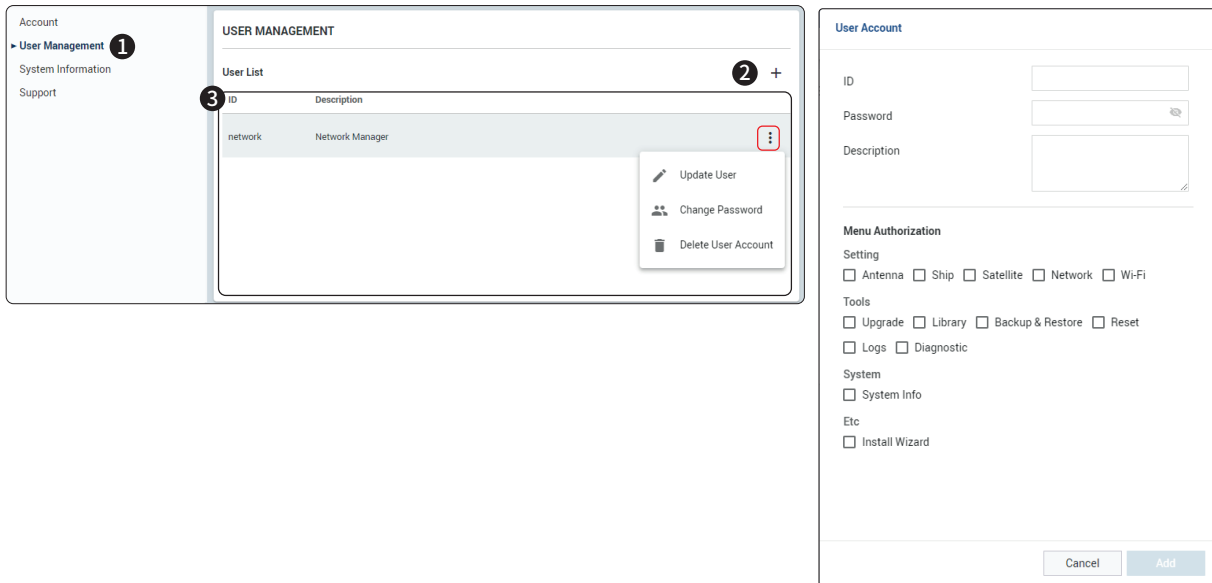

Editable User Permission Menu

No.	Item	Description
①	User Management	Sets the a user ID and password information.
②	Add User	Creates new user accounts. To create a new user account, do the following: <ol style="list-style-type: none"> 1. Click the (+) (Add) button. The User Account window is displayed. 2. Enter the new user ID, Password, and Description (optional). 3. Under Menu Authorization, select the pages to which you want the user to have access. 4. Click the Add button.
③	User Management List	Sets the User information and Permission. <ul style="list-style-type: none"> • ID: Displays the registered user ID. • Description: Displays the user's description. • ⓘ (Controls): Click the control, and then select one of the following commands to manage the selected user account. <ul style="list-style-type: none"> - Update User: Displays the User Account window. Change the user ID or choose user permissions by selecting the checkboxes, and then click the Apply button. The user can access only the selected permissions. - Change Password: Displays the Change Password dialog box. Enter the Old and New passwords, and then click the Apply button to set the new password. The next time the user logs in, the new password will be required. - Delete User Account: Displays a confirmation dialog box. Click OK to delete the user account.

9.5.3 System Information

No.	Item	Description
①	System Information	Use this page to display system information and change the antenna name.
②	System Information (Sub-Menu)	Displays detailed antenna information.
③	Antenna Information	Enters the Antenna Name. Click the Apply button to set the antenna name.

9.5.4 Support

The screenshot shows the 'Support' section of the AptusNTV interface. On the left, a sidebar lists navigation options: Account, User Management, System Information, and Support (marked with a circled 1). The main content area is titled 'SUPPORT' and is divided into three sections:

- 2 Manual**: Contains two buttons: 'Download Manual' and 'Support Desk'.
- 3 FAQ**: A list of frequently asked questions, including:
 - Where can I find information on Intellian APTUS software?
 - What are the power requirements for the New TVRO and the ACU?
 - Can I use the existing cables I have installed on my boat to connect the TVRO antenna and ACU?
 - What is the local oscillator (LO) stability of the Intellian WorldView LNB?
 - Where can I find the System Diagram for Intellian products?
 - Where can I download the service manual for my New TVRO antenna?
 - What is the heading (NMEA) sentence Intellian antenna supports?
 - Are Intellian Products and Spare Parts RoHS compliant?
 - Does Intellian provide the ET Test Report for the products?
 - What is the recommended material for the mounting pedestal to install Intellian antennas?
 - What is the best storage environment for the TVRO crates prior to installation?

No.	Item	Description
①	Support	Supports manual downloading, support desk and FAQ list.
②	Manual	Downloads the User Manual and displays Support Desk information. <ul style="list-style-type: none"> Download Manual: Click the Download Manual button to view the User Manual. Support Desk: Click the Support Desk button to open Intellian's contact details for support.
③	FAQ	Provides answers for frequently asked questions about the product.

9.6 Dashboard

The Dashboard menu item provides access to quick monitoring of the antenna status. Once displayed, the Dashboard helps you arrange panels on a single screen, while providing you with a broad view of a variety of information at once. You can customize the dashboard by rearranging the panels to make them more readable and user-friendly.

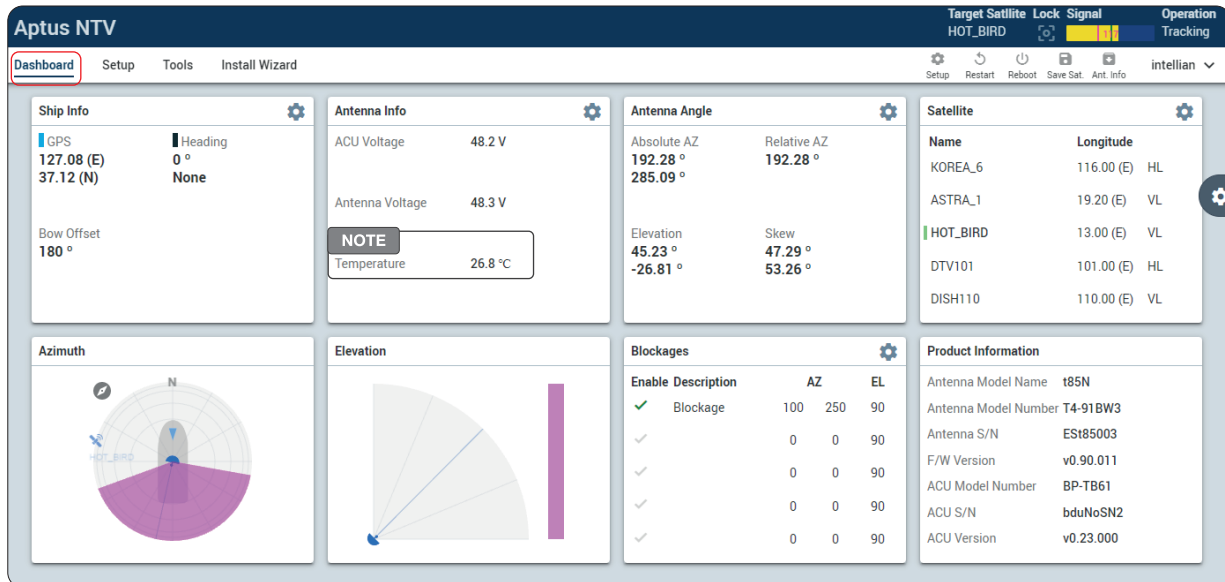

NOTE

The measured temperature can be different from the actual temperature.

9.6.1 How to Add & Remove Panels (Dashboard Setting)

Adding Panels

1. Click the gear icon on the right side of the page (see figure below). The Dashboard Setting window displays.
2. Check the box of the panel that you wish to add to the dashboard.
3. Click the **Confirm** button to apply the settings to the system.

Once the panel is added, it will be automatically placed at the bottom of the page.



NOTE

You can customize the dashboard by rearranging panels as you wish.

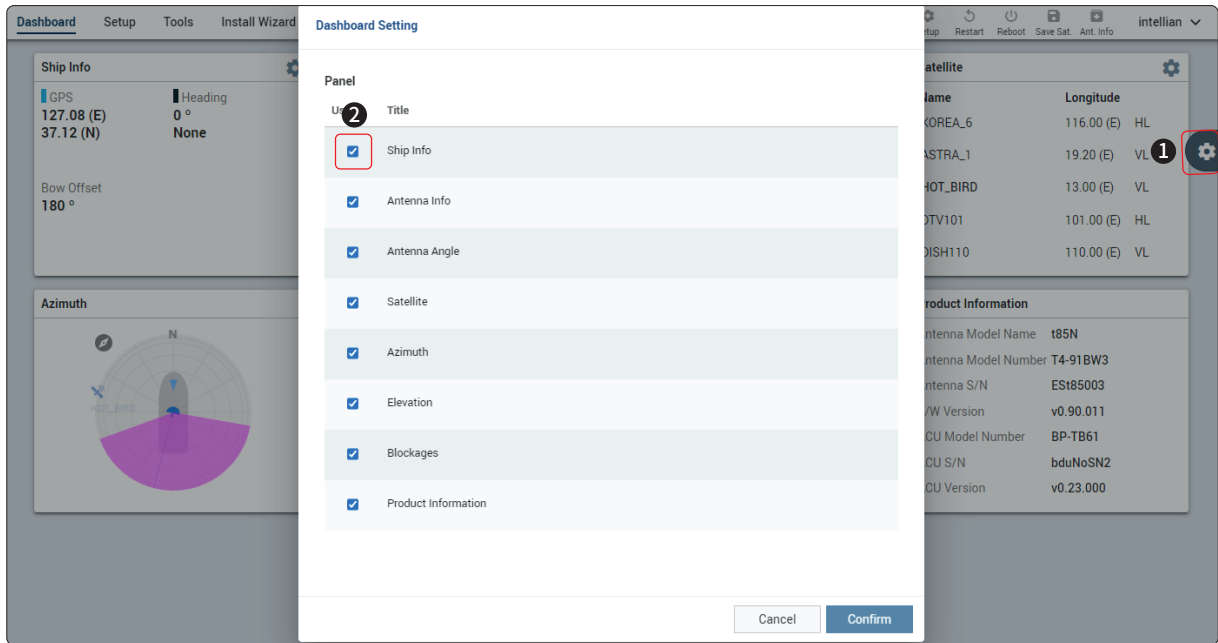

Removing Panels

1. Click the gear icon on the right side of the page (see figure below). The Dashboard Setting window displays.
2. Uncheck the box of the panel that you wish to remove from the dashboard.
3. Click the **Confirm** button to apply the settings to the system.

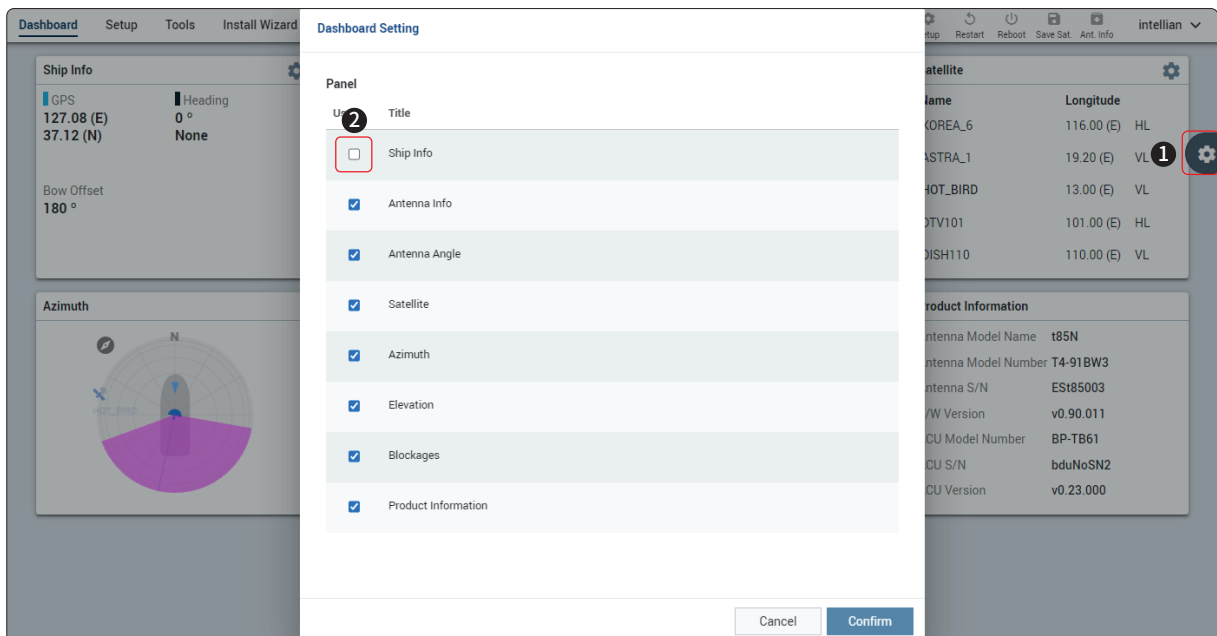

9.6.2 How to Use Shortcut Settings

Many panels on the dashboard provide a shortcut function. Using the **Shortcut** button on right side of the panel, you can easily access detailed information and manage settings.

1. Click the **Shortcut** button indicated by the red mark to open the setting page.

The screenshot shows a dashboard with several panels. The 'Ship Info' panel has a gear icon highlighted with a red circle. Other panels include 'Antenna Info', 'Antenna Angle', 'Satellite', 'Azimuth', 'Elevation', 'Blockages', and 'Product Information'.

Ship Info	
GPS	Heading
127.08 (E)	0 °
37.12 (N)	None
Bow Offset	
180 °	

Antenna Info	
ACU Voltage	48.2 V
Antenna Voltage	48.3 V
Temperature	26.8 °C

Antenna Angle	
Absolute AZ	Relative AZ
192.28 °	192.28 °
285.09 °	
Elevation	Skew
45.23 °	47.29 °
-26.81 °	53.26 °

Satellite	
Name	Longitude
KOREA_6	116.00 (E) HL
ASTRA_1	19.20 (E) VL
HOT_BIRD	13.00 (E) VL
DTV101	101.00 (E) HL
DISH110	110.00 (E) VL

Azimuth	
[Azimuth display showing a compass rose and antenna position]	

Elevation	
[Elevation display showing a sector and antenna position]	

Blockages			
Enable	Description	AZ	EL
✓	Blockage	100	250
✓		0	0
✓		0	0
✓		0	0
✓		0	0

Product Information	
Antenna Model Name	185N
Antenna Model Number	T4-91BW3
Antenna S/N	ES185003
F/W Version	v0.90.011
ACU Model Number	BP-TB61
ACU S/N	bduNoSN2
ACU Version	v0.23.000

2. The setting page will appear on an individualized web page. You can check the detailed information and quickly apply the settings that you wish.

9.7 Setup

This menu sets and displays the Ship, Antenna, Satellite, Network, Wi-Fi, and Mediator.

9.7.1 Ship

- ▶ Ship **1**
- Antenna
- Satellite
- Network
- Wi-Fi

SHIP

2 GPS ⓘ

Longitude(°) EAST

Latitude(°) NORTH

3 Heading Device ⓘ

Current Device

Baud Rate

Heading(°)

4 BOW Offset ⓘ

Current Bow Offset(°)

5 Blockage ⓘ

Enable	Description	Az. Start-End (°)		El. (°)
<input checked="" type="checkbox"/>	<input type="text" value="Blockage1"/>	<input type="text" value="185"/>	~ <input type="text" value="205"/>	<input type="text" value="20"/>
<input type="checkbox"/>	<input type="text"/>	<input type="text" value="0"/>	~ <input type="text" value="0"/>	<input type="text" value="0"/>
<input type="checkbox"/>	<input type="text"/>	<input type="text" value="0"/>	~ <input type="text" value="0"/>	<input type="text" value="0"/>
<input type="checkbox"/>	<input type="text"/>	<input type="text" value="0"/>	~ <input type="text" value="0"/>	<input type="text" value="0"/>
<input type="checkbox"/>	<input type="text"/>	<input type="text" value="0"/>	~ <input type="text" value="0"/>	<input type="text" value="0"/>

No.	Item	Description
①	Ship	Sets the ship information and blockage zones.

83

No.	Item	Description
②	GPS	<p>Sets the GPS position of the vessel for searching for a satellite. Check the GPS status connected to the antenna system. The indicator to the left of the help button shows the GPS status. Make sure the GPS indicator is Blue.</p> <p>GPS Indicator :</p> <p>Blue: the system received a correct GPS input. Black: the system has not received a GPS input. You can enter the GPS value manually to set the GPS position.)</p> <ul style="list-style-type: none"> • Longitude (°): Set Longitude information (East / West). • Latitude (°): Set Latitude information (North / South). <p>Click the Apply button to apply the settings to the system.</p>
③	Heading Device	<p>Sets the ship's heading device. Choose the device type from the Current Device drop-down list. The indicator to the left of the help button shows the device connection status.</p> <p>Heading Device Indicator</p> <p>Blue: a ship's heading device is connected. Black: a ship's heading device is not connected.)</p> <ul style="list-style-type: none"> • Current Device: Select the heading device (None, NMEA, NMEA2000 Static).If you select NMEA, you can also set the Baud Rate. • Heading(°): Enter the heading information. <p>Click the Apply button to apply the settings to the system.</p>
④	Bow Offset	<p>For setting the bow offset, you need to select a satellite which is trackable in satellite library information. When the antenna tracks the selected satellite, bow offset will be set up automatically.</p> <ul style="list-style-type: none"> • Current Bow Offset (°): Enter the Bow Offset Range (0 – 360°). <p>Click the Apply button to apply the settings to the system.</p>
⑤	Blockage	<p>Up to five antenna blockage zones can be set by entering the relative azimuth and elevation sectors where line of site will be blocked. Setting blockage zones ensures that the programs viewers watch won't be interrupted by keeping the antenna from pointing to those zones.</p> <p>The Az. Start is the relative azimuth angle where the blockage starts, and the Az. End is the relative azimuth where the blockage ends (Range: 0 ~ 360). The El. is the elevation angle where the blockage is set (Range: 0 ~ 90). The blockage is activated below the elevation angle.</p> <p>Click the Apply button to apply the settings to the system.</p>

9.7.2 Antenna Setting

Ship

▶ **Antenna 1**

Satellite

Network

Wi-Fi

ANTENNA

2 Antenna Angle

Relative Azimuth 97.51

Absolute Azimuth 97.51 / 281.02 < 5 >

Elevation 44.44 / -22.27 v 5 ^

LNB Pol Angle 39.50 / 63.43 < 1 >

3 Thresholds Setting

Tracking Level

Detect Level

4 Search Parameter

Search Step(°)

Search1 Azimuth(°)

Search1 Elevation(°)

Search3 Azimuth(°)

Search3 Elevation(°)

5 Conical Range

Azimuth

Elevation

6 Conical Range Check

Switch Activation

7 EI Adjust

EI Adjust(°)

8 Tilt Sensor Bias

EL 0.00 v 1 ^

CL 0.00 v 1 ^

9 Rate Sensor Bias

Az

EI

CI

10

No.	Item	Description
①	Antenna	Sets current antenna position and search parameters. These parameters should only be changed by an authorized service technician. Improper setting of these parameters will render your system inoperable.
②	Antenna Angle	<p>The system must be in Setup Mode to modify these settings.</p> <p>Sets current antenna position. You can move the antenna's azimuth and elevation position by using the arrows or inputting a value to find the desired satellite manually.</p> <ul style="list-style-type: none"> • Relative Azimuth: Displays the antenna's relative azimuth angle. • Absolute Azimuth: Adjusts the antenna's absolute azimuth angle. • Elevation: Adjusts the elevation angle. • LNB Pol Angle: Adjusts the LNB Pol angle. <p>Click the Apply button to apply the settings to the system.</p>
③	Thresholds Setting	<p>Sets current detect level threshold and tracking level threshold.</p> <ul style="list-style-type: none"> • Tracking Level: Enter the current tracking level threshold. • Detect Level: Enter the current detect level threshold. <p>Click the Apply button to apply the settings to the system.</p>
④	Search Parameter	<p>Sets the time-out, search step and search range.</p> <ul style="list-style-type: none"> • Search Step(°): Set increment step size. • Search1/3: Set Search 1 and 3 search range. Search is conducted in a two-axis pattern consisting of alternate movements in azimuth and elevation to form an expanding square. <p>Click the Apply button to apply the settings to the system.</p>
⑤	Conical Range	<p>The relative force of the motors controlling azimuth and elevation. Sets the conical range while the antenna is in tracking mode.</p> <p>Click the Apply button to apply the settings to the system.</p>
⑥	Conical Range Check	<p>The system must be in Setup Mode to modify these settings.</p> <p>Monitors the Azimuth and the elevation value when the conical range is modified.</p> <ul style="list-style-type: none"> • Switch Activation: Choose whether to use the switch activation function (On / Off).
⑦	EL Adjust	<p>Sets Elevation Offset angle. You can adjust Elevation Offset by inputting a value to find the desired satellite manually.</p> <p>Click the Apply button to apply the settings to the system.</p>
⑧	Tilt Sensor Bias	<p>NOTE: <i>The rate values of the azimuth, elevation, and cross-level axes were calibrated to the optimal condition at the factory prior to shipment. If the additional rate adjustment is required, make sure that the antenna is placed on a rigid and flat platform. During the calibration process, the antenna must avoid any motion as it can affect the antenna's performance.</i></p> <p>Maintain the elevation and the cross-level axes to keep the pedestal parallel to the horizon.</p> <ul style="list-style-type: none"> • Ready: Click the Ready button to bring the elevation and cross-level to 0. • EL/CL: Select EL/CL and click the Up and Down arrow keys to adjust the elevation and cross-level.

No.	Item	Description
⑨	Rate Sensor Bias	<p>NOTE: <i>The rate values of the azimuth, elevation, and cross-level axes were calibrated to the optimal condition at the factory prior to shipment. If the additional rate adjustment is required, make sure that the antenna is placed on a rigid and flat platform. During the calibration process, the antenna must avoid any motion as it can affect the antenna's performance.</i></p> <p>Calibrates DC voltage output from the three rate sensors used to sense antenna motion in azimuth, elevation and cross-level axes. These are used to sense antenna motion that corresponds to the ship's motion (roll, pitch, and yaw) for stabilizing the pedestal. The DC voltage output from each of the rate sensors may vary by an amount which is directly proportional to the direction and rate of motion induced on it.</p> <ul style="list-style-type: none"> • Rate Sensor Calibration: Click the Rate Sensor Calibration button to calibrate the rate sensor automatically. The indicator left of the help button shows the rate sensor calibration status. <ul style="list-style-type: none"> - Black: The calibration is ready to start. - Blue: The calibration is completed. - Red: The calibration is failed. - Green: The calibration is in process. • Save Sensor Bias: Click the Save Sensor Bias button to save the calibrated value of the rate sensor to the system.
⑩	Set Idle Mode	<p>Sets the motor to idle mode to check the antenna's balance.</p> <ul style="list-style-type: none"> • Set Idle Mode: The system must be in Setup Mode to modify this setting. Releases the elevation and cross-level motor. • Reboot: Reboots the system.

9.7.3 Satellite Set

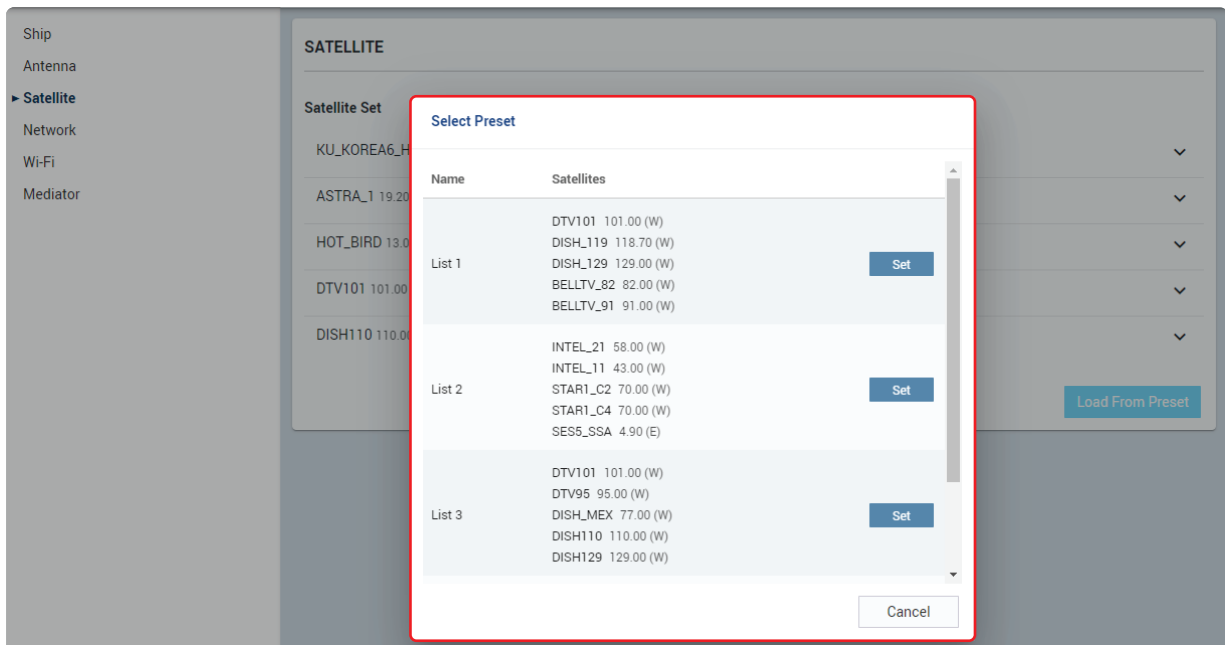
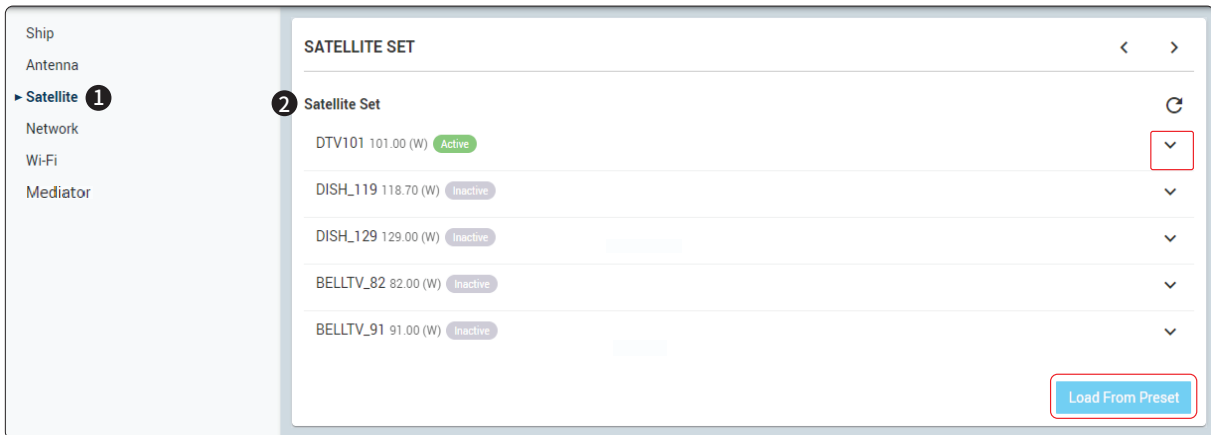

No.	Item	Description
①	Satellite	Sets the current tracking satellite from the library and edits the satellite information.
②	Satellite Set	<p>Sets the current tracking satellite from the library and edits the satellite information.</p> <p>Select the active satellite from the set. The Inactive icon will change to a green Active icon. You can check the satellite information of the activate satellite by clicking <input type="checkbox"/>. You can then edit satellite information or change the activate satellite from the library.</p> <p>To change the satellite set, click the Load From Preset button.</p>

9.7.4 Network

The screenshot shows the 'NETWORK' configuration page. On the left sidebar, 'Network' is selected with a circled '1'. The main content area has three sections:

- 2 Management Port Configuration**: Contains input fields for IP Address (192.168.2.1), Subnet Mask (255.255.255.0), Lease Start Address (192.168.2.101), Lease End Address (192.168.2.200), and Lease Time (604800). Buttons for 'Cancel' and 'Apply' are at the bottom.
- 3 Ethernet Port Configuration**: Contains input fields for IP Address (10.1.124.47), Subnet Mask (255.255.254.0), and Gateway (10.1.124.254). Buttons for 'Cancel' and 'Apply' are at the bottom.

No.	Item	Description
①	Network	Sets the ACU's internal IP address and ports.
②	Management Port Configuration	<p>Sets the Management Port's network configuration. The Management Port is located on the ACU front panel.</p> <ul style="list-style-type: none"> • IP Address: Set the network IP address (Factory default: 192.168.2.1). • Subnet Mask: Set the subnet mask (Factory default: 255.255.255.0). • Lease Start Address: Set the lease IP address start range. DHCP will only assign IP addresses within the start and end range. • Lease End Address: Set the lease IP address end range. • Lease Time: Set the lease IP address update time. This is the amount of time in seconds (default 604800 seconds or 7 days) that an IP address is reserved for a network device. <p>Click the Apply button to apply the settings to the system.</p>
③	Ethernet Port Configuration	<p>Sets the network configuration of the Ethernet port on the ACU back panel. For service only.</p> <ul style="list-style-type: none"> • IP Address: Set the network IP address (Factory default: 192.168.0.223). • Subnet Mask: Set the subnet mask (Factory default: 255.255.255.0). • Gateway: Set the gateway IP address (Factory default: 192.168.0.223). <p>Click the Apply button to apply the settings to the system.</p>

9.7.5 Wi-Fi

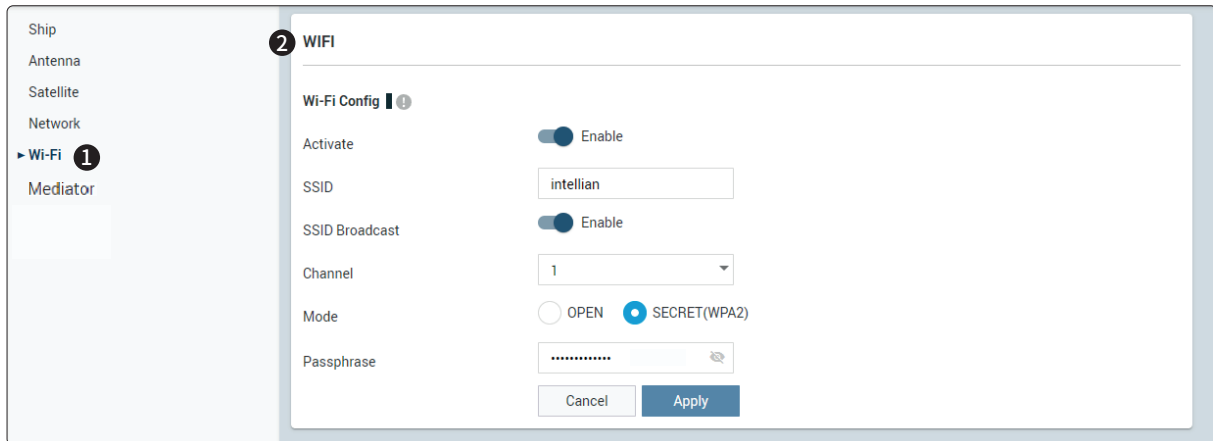

No.	Item	Description
①	Wi-Fi	Sets up the Wi-Fi connection of ACU.
②	Wi-Fi Config	<p>Displays Wi-Fi configuration. Connect the Wi-Fi dongle to the USB port on the ACU rear panel. When Wi-Fi is enabled, the indicator to the left of the help icon is either blue (Wi-Fi broadcasting) or black (Wi-Fi not broadcasting).</p> <ul style="list-style-type: none"> • Activate: Sets the Wi-Fi function by toggling the activation button (Enabled/Disable). • SSID: The SSID is the name that allows devices to identify and connect to the wireless network. The SSID is case-sensitive and must not exceed 32 alphanumeric characters, and it can be any keyboard character. The SSID is the same for all devices that connect to your wireless network. • SSID Broadcast: Sets the SSID broadcast function by toggling the activation button (Enabled/Disable). • Channel: Selects an appropriate channel from the list provided to correspond with your network settings. All devices that connect to your wireless network will use the same channel automatically. Try to avoid conflicts with other wireless networks by choosing a channel where the upper and lower three channels are not in use. • Mode: Set the security mode type (Open/Secret). • Passphrase: Enter the password required to connect to Wi-Fi. <p>Click the Apply button to apply the settings to the system.</p>

9.7.6 Mediator (Optional)

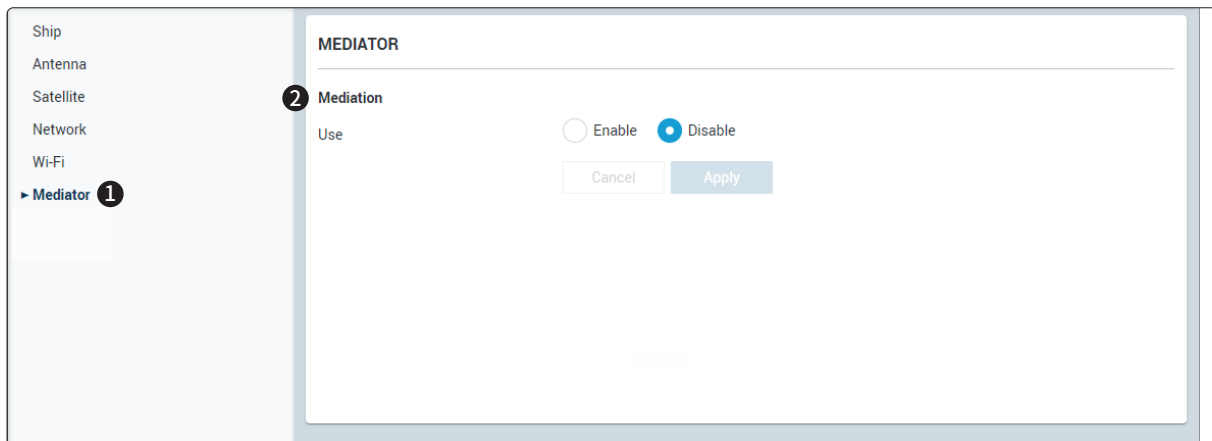

No.	Item	Description
①	Mediator	Sets up the dual antenna mediation function.
②	Mediation	<p>Sets up the mediation function. This function works in a dual antenna system with a dual TVRO mediator.</p> <ul style="list-style-type: none"> • Use: Set up the mediation function by selecting Enable or Disable. <p>Click the Apply button to apply the settings to the system.</p>



NOTE

The Dual TVRO Mediator is sold separately. Refer to the Dual TVRO Mediator User Manual for installation and operation.

9.8 System Tools

This menu sets and displays the ACU Upgrade, F/W Upgrade, Library, Satellite Preset, Backup & Restore, Reset, Logs and Diagnostic system tools.

9.8.1 ACU Upgrade

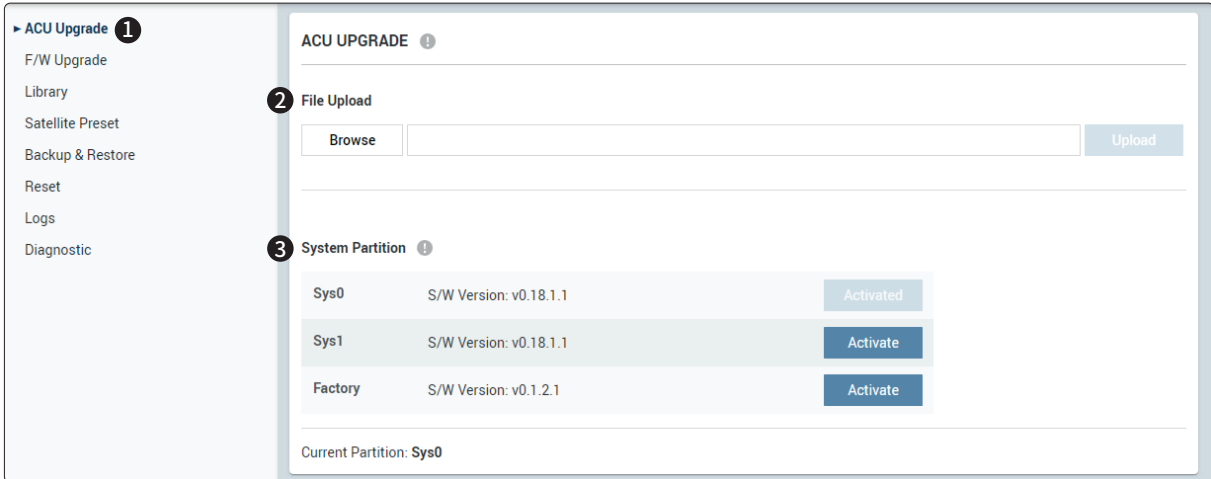

No.	Item	Description
①	ACU Upgrade	Upgrades antenna software.
②	File Upload	Browse and select the package upgrade file to upload, and then click the Upload button. The update may take a few minutes to complete. The upload time may vary due to a variety of factors, such as network speed. Uploading an incorrect file may cause serious damage to your antenna and ACU. Refer to the following " Antenna Software Upgrade Procedure " page for more details.
③	System Partition	<p>The ACU has three storage partitions the Sys0, the Sys1 and the Factory Default. Selects the desired storage partitions and click the Activate button. The currently active partition is unavailable for selection.</p> <ul style="list-style-type: none"> • Sys0: Displays the Sys0 host controller software version. • Sys1: Displays the Sys1 host controller software version. • Factory Default: Displays the Factory Default host controller software version. • Current Partition: Displays the activated storage partition name (Sys0, Sys1 or Factory Default).

Antenna Software Upgrade Procedure:



WARNING

Please do not turn off the power during the upgrade.

1. Click the **Browse** button and, in the Windows Open dialog box, select the upgrade package file to upload.
2. Click the **Upload** button to transfer the firmware package file (*.bin) to the Antenna module. The antenna software versions are displayed in a new window.



NOTE

If you select the box "Ignore warnings during installation and force the installation to continue", warning messages do not appear during the upgrade.

3. Check the current version installed and the new version available, and then click the **Update** button.

Name	Current	New
ACU	0.21.2	0.23.0

During the upgrade process, the window will display progress status.

Name	Progress	Status
ACU	100%	Success

If the software is successfully upgraded, Success is displayed in the Status column.

Name	Progress	Status
ACU	100%	Success

4. Click the **Done** button to close the update window.

9.8.2 Firmware Upgrade

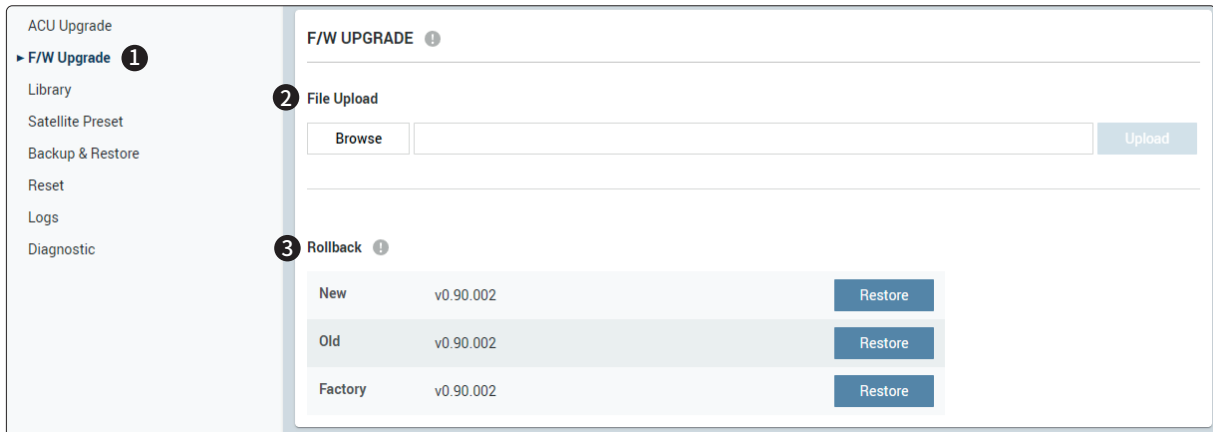

No.	Item	Description
①	F/W Upgrade	Upgrades the firmware of antenna.
②	File Upload	Browse and select the firmware file to upload, and then click the Upload button. The upload may take a few minutes to complete. The upload time may vary due to a variety of factors, such as your network speed. Uploading an incorrect firmware file may cause serious damage to your antenna and ACU. Refer to the following " Antenna Firmware Upgrade Procedure " page for more details.
③	Roll Back	Displays the new, previous/latest, and factory default firmware package versions and allows you to rollback to them. <ul style="list-style-type: none"> • New: Restores to the latest firmware version. • Old: Restores to the previous firmware version. • Factory: Restores to factory default firmware version.

Antenna Firmware Upgrade Procedure:



WARNING

Please do not turn off the power during the upgrade.

1. Click the **Browse** button and, in the Windows Open dialog box, select the upgrade package file to upload.
2. Click on the **Upload** button to transfer the Firmware file (*.fwp) to the Antenna module. The antenna Software versions are displayed in a new window.



NOTE

If you select the box "Ignore warnings during installation and force the installation to continue", warning messages do not appear during the upgrade.

3. Check the current version installed and the new version available, then click the **Update** button.

Name	Current	New
F/W	0.90.011	0.91.001

During the upgrade process, the window will display progress and status.

Name	Progress	Status
F/W	100%	Success



If the software is successfully upgraded, Success will be displayed in the Status column.

Name	Progress	Status
F/W	100%	Success

4. Click the **Done** button to close the update window.

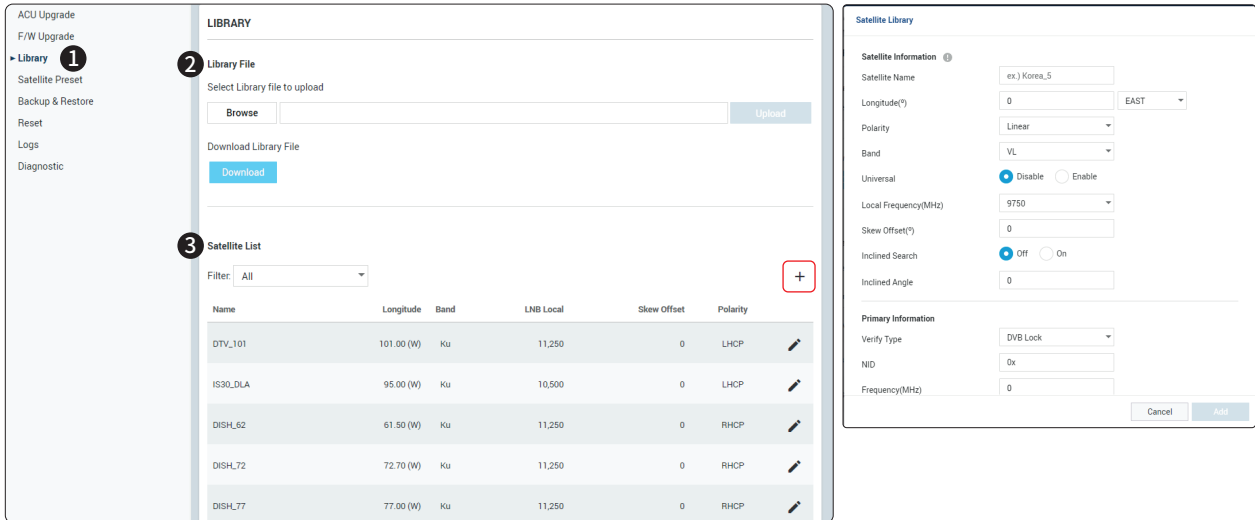
9.8.3 Library



No.	Item	Description
①	Library	Displays and edits the satellite library information.
②	Library File	<p>Upload or download the satellite library.</p> <ul style="list-style-type: none"> • Select a library file to upload: Click Browse button to select the library file to upload, and then click the Upload button. The update may take a few minutes to complete. • Download a library file : Library data (.isl) can be downloaded. Click the Download button.
③	Satellite List	<p>Displays the satellite list and information.</p> <ul style="list-style-type: none"> • Filter: Select the filter option (All, 160E~73E, 73E~0E, 0W~61W, 61W~160W) from the drop-down list. • Edit() button: To edit the registered satellite , click the Edit () button. The Satellite Library pop-up window is opened. You can edit the following details. <ul style="list-style-type: none"> - Satellite Information: Sets the current tracking satellite settings. <ul style="list-style-type: none"> • Satellite Name: Enters the satellite name. • Longitude(°): Enters the satellite orbit position. • Polarity: Selects the polarity from the drop-down list. • Band: Selects the band from the drop-down list. • Local Frequency(MHz): Selects the local frequency from the drop-down list. • Skew Offset(°): Enters the skew offset. • Inclined Search: Sets the inclined search. • Inclined Angle: Enters the inclined angle value. - Primary Information: Sets primary tracking information. <ul style="list-style-type: none"> • Verify Type: Select verify type (AGC Only, DVB Lock, DVB Decode or DSS Decode) from the drop-down list. • NID: Enters the network ID for the frequency. • Frequency(MHz): Enters the tracking frequency of the satellite. <p>Click the Apply button to apply the settings to the system.</p>

9.8.4 Satellite Preset

No.	Item	Description
①	Satellite Preset	Displays and Sets the satellite preset option.
②	Satellite Preset list	Selects a registered satellite preset from the drop-down list. You can change a preset list name. Click Change Preset Name and change it.
③	Satellite Set	Creates the satellite preset from the library. Click the Add Set button. <ul style="list-style-type: none"> name: Enters a preset list name. Satellite List: Adds a satellite from the library. Click the + button and select the satellite. Click the Create button to register the preset list.
④	Satellite	Displays current preset satellites. You can edit satellite information or prest list. <ul style="list-style-type: none"> Edit Satellite: Edits detailed satellite information. Select from Library: Edits the current preset list by selecting a new satellite from the library. Delete Preset: Delete current preset list. Change Preset Name: Changes the name of the current preset list.

9.8.5 Backup & Restore

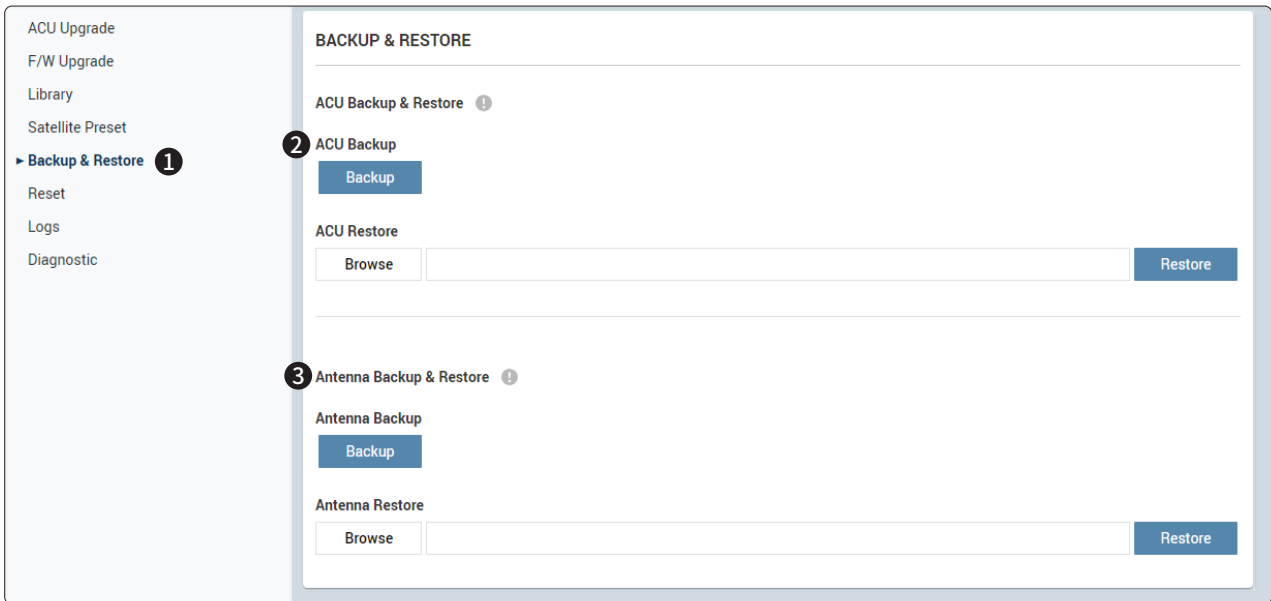

No.	Item	Description
①	Backup and Restore	Backs up user configuration files to PC and Restores the ACU/Antenna settings.
②	ACU Backup & Restore	<p>Backs up or restores ACU setting.</p> <ul style="list-style-type: none"> ACU Backup: Stores user Host configuration files on your PC. Click the Backup button to store the ACU configuration on your PC. ACU Restore: Restores the ACU settings using the setting files saved on your PC. Click the Browse button to select the saved backup file from your PC, and then click Restore button to restore the ACU setting.
③	Antenna Backup & Restore	<p>Backs up or restores antenna settings.</p> <ul style="list-style-type: none"> Antenna Backup: Stores user antenna configuration files on your PC. Click the Backup button to store the antenna configuration on your PC. Antenna Restore: Restores the antenna setting by using the setting files saved on your PC. Click the Browse button to select the saved backup file from your PC, and then click the Restore button to restore the backup antenna settings to the system.

9.8.6 Reset

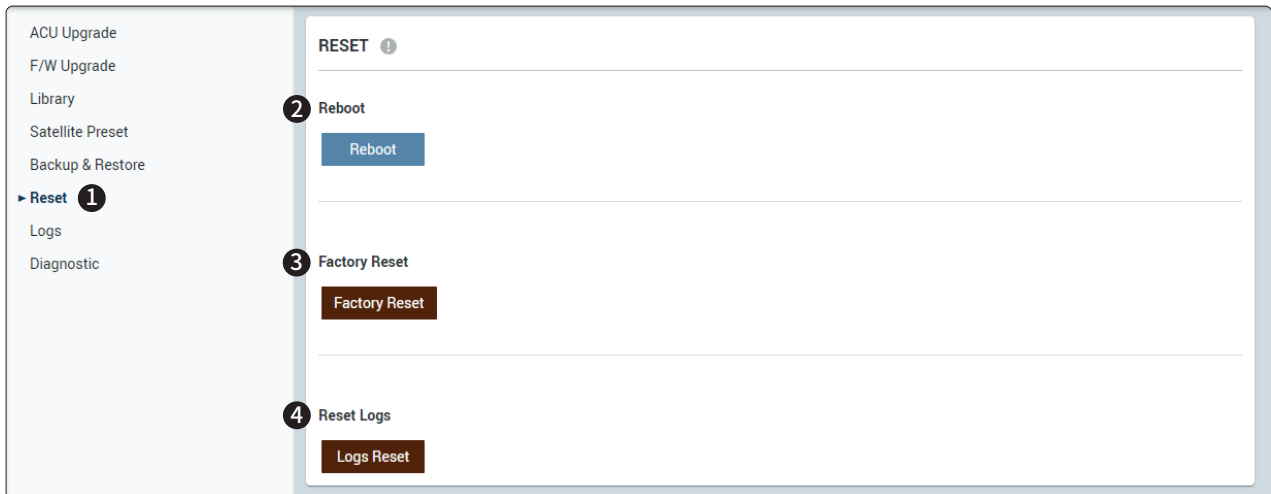

No.	Item	Description
①	Reset	Resets the antenna system, settings and logs.
②	Reboot	Click the Reboot button to reboot the antenna system. The user configuration is not reinitialized.
③	Factory Reset	Click the Factory Reset button to initialize the antenna system. The user configuration is initialized.
④	Reset Logs	Click the Logs Reset button to initialize all logs. the antenna system and logs are cleared.

9.8.7 Logs

No.	Item	Description
①	Logs	Downloads the antenna log data.
②	Log Download	<p>Allows you to download ACU and antenna log files for a specified date range.</p> <ul style="list-style-type: none"> • From/To: Sets the date range for which you want to download files. Any log data up to a month old can be downloaded. • Include Antenna Backup: Downloads antenna log files along with the ACU log files. If you do not select this option, only ACU log files will be downloaded. • Download Log File: Downloads the specified log files in a compressed archive file (.tgz).

9.8.8 Diagnostic

The screenshot shows the 'DIAGNOSTIC' interface. On the left, a sidebar lists various system management options, with 'Diagnostic' highlighted and marked with a circled '1'. The main content area is titled 'DIAGNOSTIC' and features a table with three columns: 'Test', 'Status', and 'Result'. A top checkbox, marked with a circled '2', is labeled 'Diagnostic'. Below this, the table lists several tests, each with its own checkbox. At the bottom of the table area is a blue 'Start' button.

Test	Status	Result
<input type="checkbox"/> Ant. Communication	-	
<input type="checkbox"/> Az Motor	-	
<input type="checkbox"/> El Motor	-	
<input type="checkbox"/> Cl Motor	-	
<input type="checkbox"/> Skew	-	
<input type="checkbox"/> Sensor	-	
<input type="checkbox"/> LNB	-	
<input type="checkbox"/> Antenna Power	-	
<input type="checkbox"/> ACU Power	-	

No.	Item	Description
①	Diagnostic	Executes antenna Diagnostic test to check the antenna status.
②	Diagnostic	Select the checkbox for each test that you want to run on the system. You can select all the tests quickly by selecting the top checkbox. Click the Start button to run the test.

9.9 Install Wizard

Refer to "7.3 Starting Install Wizard" on page 53 for more details.

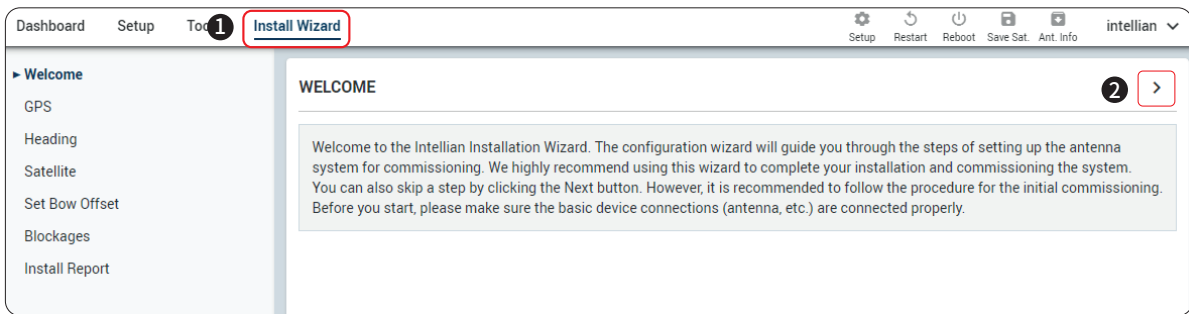

Chapter 10. Specification

10.1 Technical Specification

Above Deck Unit (ADU: Antenna)			
Antenna Radome Height		1724 mm (67.9")	
Antenna Radome Diameter		Ø1681 mm (66.2")	
Antenna Reflector Diameter		Ø1250 mm (49.2")	
Antenna Unit Weight (with Radome)		139 kg (306.4 lbs)	
Platform		3-axis: Azimuth, Elevation, Cross-level	
Positioning		3-axis Velocity Mode Servo Control: Azimuth, Elevation, Cross-Level	
Pedestal Motion Range	Azimuth Range		Unlimited
	Elevation Range		-15° to +115°
	Cross-level Range		Up to ±42°
Stabilization Accuracy		0.2° max in presence of specified ship motions	
Ship Motions	Roll		±25° at 6 second
	Pitch		±15° at 6 second
	Yaw		±8° at 6 second
	Turning Rate		Up to 10°/sec ²
AZ/EL/CL Motor		Brushless DC motor with Encoder embedded	
Sensor		3 Gyro-Rate Sensors & 1 Tilt Sensor (Fixed Sensor)	
Rx	Ku-Band	Frequency	10.7 GHz ~ 12.75 GHz
		Gain	> 42.2 dBi @ 11.7 GHz (excl/ Radome)
	Ka-Band	Frequency	18.3 GHz ~ 20.2 GHz
		Gain	> 43.0 dBi @ 18.55 GHz (excl/ Radome) > 44.0 dBi @ 19.95 GHz (excl/ Radome)
	Ka-Band	99.2°	1.8°±0.3°
		102.8°	2.2°±0.3°
Polarization	Ku-Band		Linear & Circular Polarization
	Ka-Band		Circular Polarization
Feed Assembly		Cassegrain type	
Minimum EIRP	Ku-Band		41.0 dBW
	Ka-Band		44.0 dBW
LNB		New 5-ports WLNB	
ACU to ADU Cable (Antenna Cable)		Single 75 Ω coax RF cable connected from ACU to ADU for FSK and DC Power	
Input Power		ACU provide 48 VDC (Max. 500 W) over the Antenna Cable	

Below Deck Unit (ACU)	
ACU Size	431 mm x 350 mm x 44.3 mm (17.0" x 13.8" x 1.7")
ACU Weight	4.8 kg (10.6 lbs)
Display	256 x 64 Graphic OLED
Key	Two Push Keys
LED Indicator	Three LEDs for Power, Tracking and Error
USB Port	Two Ports at front panel and One for Wi-Fi dongle at rear panel
Ship's Gyrocompass Interface	NMEA 2000, NMEA 0183
GPS Interface	GPS IN/OUT
Ethernet port	One Management Port at front panel and One External Port at rear panel
Input power	100-240 VAC, 50-60 Hz, 3.3 A
Output Power	48 VDC for ADU (Antenna)
Multi-Switch Module (MSM)	
MSM Size	431 mm x 360 mm x 44.3 mm (17.0" x 14.2" x 1.7")
MSM Weight	5.3 kg (11.7 lbs)
LED Indicator	One LED for Power
Connector	Antenna Interface: F-Type (RF1~RF4) SWM compatible STB Interface: F-Type (SWM1, SWM2) Universal STB Interface: F-Type (OUT1~8)
Input Power	100-240 VAC, 50-60 Hz, 1.5 A

10.2 Environmental Specification

Test	Intellian Standard	
Temperature (ADU)	Operational	IEC-60945 (-25° C to +55° C, Power On)
	Survival	IEC-60945 (-40° C to +80° C, Powered On and a non-functional state)
	Storage	IEC-60945 (-40° C to +85° C, Power off)
Temperature (ACU)	Operational	IEC-60945 (-15° C to +55° C)
	Survival	IEC-60945 (-25° C to +70° C)
	Storage	IEC-60945 (-40° C to +85° C)
Wind	56 m/sec (125 mph)	
Humidity	IEC-60068-2-30 Upper Test Temp: +40° C (-3), Humidity 98% Lower Test Temp.: +15° C (+3), Humidity 71% ~ 78%	
Vibration	Operational	IEC-60945, Method: IEC60068-2-6 Freq.: 5 to 13.2 Hz/1mm 13.2 to 100 Hz/0.7g Sweep rate 0.5 Oct/min
	Survival	IEC-60721-3-6 Class 6M3, Method: IEC 60068-2-6 Freq.: 4 to 18 Hz/1.5mm 18 to 200 Hz/2g Sweep rate 1 Oct/min
Shock	Operational	IEC-60721-2-27 2 g/20 ms, 4 g/20 ms, 10 g/11 ms, 20 g/7 ms ±X, ±Y, ±Z each Axis 3 Times
	Survival	IEC-60721-3-6 Class 6M3 10 g/11 ms, 30 g/6 ms, 50 g/3 ms ±X, ±Y, ±Z each Axis 3 Times
	Bump	IEC-60721-3-6 Class 6M3 25 g/6 ms ±X, ±Y, ±Z each Axis 100 Times
Salt Mist	Saline solution : 5 ±1% NaCl Storage period: 7 Days (IEC-60945)	
Waterproofing	IPX6 (IEC-60529)	
Solar	IEC 60068-2-5	

Chapter 11. Warranty

Warranty Policy

Intellian systems are warranted against defects in parts and workmanship, these warranties cover THREE (3) YEAR of parts and TWO (2) YEAR of factory repair labor to return the system to its original operational specification.

Warranty periods commence from the date of shipment from Intellian facility or date of installation, whichever is sooner. The warranty provides a maximum of 6 months additional coverage if submission of authorized form that describes installation occurs within 6 months from the shipment date.

Intellian Technologies warranty does not apply to product that has been damaged and subjected to accident, abuse, misuse, non-authorized modification, incorrect and/or non-authorized service, or to a product on which the serial number has been altered, mutilated or removed. Intellian Technologies, will (at its sole discretion) repair or replace during the warranty period any product which is proven to be defective in materials or workmanship, in accordance with the relevant product warranty policy. All products returned to Intellian Technologies, during the warranty period must be accompanied by a Service Case reference number issued by the dealer/distributor from Intellian Technologies, and (where applicable) a copy of the purchase receipt as a proof of purchase date, prior to shipment. Alternatively, you may bring the product to an authorized Intellian Technologies, dealer/distributor for repair.+

Chapter 12. Appendix

12.1 Appendix A. Tightening Torque Specification

This table shows the recommended values of tightening torques.

Bolt Size	Tightening Torque (N-m)
M2	0.5
M2.5	1
M3	1.5
M4	3
M5	6
M6	12
M8	27
M10	50
M12	85
M14	130
M16	200