

# 12 KVA International Universal Isotransformer™

SHORELINE ISOLATION TRANSFORMER

## INSTALLATION INSTRUCTIONS & OWNER'S MANUAL Model 93-IXFMR12I-A

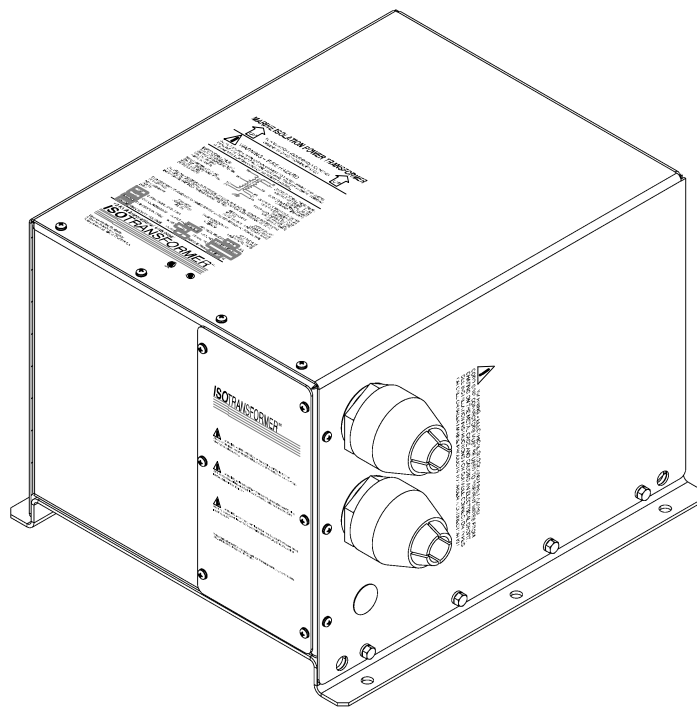

# Contents

**INTRODUCING...THE 12 KVA INTERNATIONAL UNIVERSAL ISOTRANSFORMER™** ..... 3

**Manual Purpose** ..... 3

**APPLICATION** ..... 3

**IMPORTANT SAFETY INSTRUCTIONS** ..... 3

**Warnings** ..... 3

**Installation Precaution** ..... 4

**Environmental Precaution** ..... 4

**Application Precaution** ..... 4

**Damaged Unit Precaution** ..... 4

**Disassembly Precaution** ..... 4

**INSTALLING THE ISOTRANSFORMER** ..... 5

**Choosing an Electrical Wiring Method** ..... 5

**Wired as an Isolation Transformer** ..... 5

**Wired as a Polarization Transformer** ..... 8

**Choosing Mounting Location** ..... 8

**Choosing Mounting Hardware** ..... 9

**Mounting the IsoTransformer** ..... 10

**Choosing the Appropriate Wire Type and Gauge** ..... 10

**Choosing Electrical Wiring Hardware** ..... 10

**Overcurrent Protection** ..... 11

**Making 12 KVA International Universal IsoTransformer Connections** ..... 11

**Securing Covers** ..... 15

**Applying Power** ..... 15

**OPERATING THE ISOTRANSFORMER** ..... 15

**Safety First** ..... 15

**Proper Operation** ..... 15

**MAINTAINING THE ISOTRANSFORMER** ..... 15

**TROUBLESHOOTING** ..... 16

**WARRANTY & CUSTOMER SERVICE** ..... 16

**Warranty** ..... 16

**Service Center and Repair Correspondence** ..... 16

**SPECIFICATIONS** ..... 16

**PRODUCT LABELING** ..... 17

## INTRODUCING...THE 12 KVA INTERNATIONAL UNIVERSAL ISOTRANSFORMER™

*Thank you* for purchasing the 12 KVA International Universal IsoTransformer™! Your IsoTransformer completely isolates input power from output power giving you an improved degree of safety and preventing galvanic current corrosion due to the direct connection to AC shore power. A 120 volt tap on the primary winding allows the output of 120/240 volts even when only 120 volt service is available dockside. The IsoTransformer is rated for worldwide applications using 50/60 Hertz. By using taps on the secondary winding, reduced voltage output is available to permit satisfactory operation of most 60 Hertz equipment when using 50 Hertz shorepower.

### Manual Purpose

With your personal safety in mind, this manual lists important safety precautions first, then covers installation, operation, maintenance, troubleshooting, warranty, and customer service information.

## APPLICATION

The 12 KVA International Universal IsoTransformer is a shoreline isolation transformer intended for boats with 50 amp/240 volt (12 KVA) or 50 amp/120 volt (6 KVA) service. Properly installed it will electrically isolate AC shore power from the boat's AC power system reducing galvanic current corrosion due to the AC shore power connection.

The boat's electrical system and grounding conductor are not actually connected to the shoreside system when you use the 12 KVA International Universal IsoTransformer as an isolation transformer. Power is transferred from the shoreside electrical system to the boat's electrical system by magnetic coupling. This means there is no direct electrical connection between the earth-grounded shore AC power and boat AC power systems. The shore grounding conductor is connected to a shield that is wound between the primary (shore) and secondary (boat) transformer windings. This shield assures isolation on the boat by providing a protective layer between primary and secondary windings within the transformer. In the unlikely event of a breakdown within the transformer, the shield can withstand the fault current of a properly sized shore supply circuit breaker long enough for the breaker to trip.

## IMPORTANT SAFETY INSTRUCTIONS

**SAVE THESE INSTRUCTIONS.** This manual contains important safety and operating instructions for the IsoTransformer. Read the entire manual before usage. Also read all instructions and cautions for and on the IsoTransformer.

### Warnings

#### **WARNING — HIGH VOLTAGE**

To avoid serious injury or death from high voltage electrical shock disconnect AC shore power before opening panel.

#### **WARNING — FIRE HAZARD**

Primary and secondary overcurrent protection and conductor sizing must be in accordance with manufacturer's installation instructions.

#### **WARNING**

On board and in-water shock hazard. The transformer must be connected in accordance with the manufacturer's installation instructions.

#### **WARNING — FIRE HAZARD**

Do not store equipment on or next to transformer. This unit is designed to operate hot and must have free air flow to prevent overheating or charring of adjacent material.

**WARNING — ELECTRICAL SHOCK AND FIRE HAZARD**

**Cord grip connectors must be used to prevent wires from chafing on the metal case and causing an electrical short. See installation instructions for suitable connector types or call Charles Marine Products to order a connector kit.**

**Installation Precaution**

Boat wiring is a complex task that can cause shock, corrosion and other hazards if not done properly by trained, experienced personnel. For more information on this subject contact the **American Boat and Yacht Council (ABYC)** or see the standards and regulations below:

**American Boat and Yacht Council E-11  
“AC and DC Electrical Systems on Boats”**

3069 Solomon’s Island Road  
Edgewater, MD 21037  
Telephone: 410.956.1050  
FAX: 410.456.2737

**NFPA Standard 302.  
“Pleasure and Commercial Motor Craft”**

National Fire Protection Association  
1 Batterymarch Park  
P.O. Box 9101  
Quincy, MA 02269-9401  
Telephone: 800.344.3555

**Rules and Regulations for Recreational Boats**

Excerpts from the United States Code (USC) and the Code of Federal Regulations (CFR) (U.S. Coast Guard Regulations) are available from the **American Boat and Yacht Council** listed above.

*Note: Installation of the 12 KVA International Universal IsoTransformer must be made in accordance with all applicable standards and regulations.*

**Environmental Precaution**

The 12 KVA International Universal IsoTransformer is intended for installation inside an engine room or elsewhere inside the boat. Make sure that the location will not subject the unit to rain, snow, excessive moisture, or excessive heat.

**NOTICE**

**This device is ignition-protected in accordance with U.S. Coast Guard regulations under 33 CFR 183.410.**

**Application Precaution**

These units are intended for hard-wired, permanent, on-board applications. Use of attachments not recommended or sold by Charles Marine Products may result in risk of fire, electrical shock or personal injury.

**Damaged Unit Precaution**

Do not operate the IsoTransformer if it has received a sharp blow, been dropped, immersed in water or otherwise damaged. See the section in this manual on *Warranty & Customer Service* for repair information.

**Disassembly Precaution**

Do not disassemble the IsoTransformer. See the sections in this manual on *Maintaining the IsoTransformer*, *Troubleshooting the IsoTransformer* and *Warranty & Customer Service*.

## INSTALLING THE ISOTRANSFORMER

### Choosing an Electrical Wiring Method

There are two wiring methods that can be used to install the 12 KVA International Universal IsoTransformer as an isolation transformer in accordance with *ABYC E-11 "AC and DC Electrical Systems on Boats"*. A third method, also in accordance with *ABYC E-11*, can be used to install the 12 KVA International Universal IsoTransformer as a polarization transformer if desired. The third method is not preferred, because wiring the unit in the manner described circumvents the AC grounding conductor isolation between shore and boat power and may require the use of a galvanic isolator to reduce galvanic corrosion.

*Note: Figure 1, Figure 2 and Figure 3 are reprinted with permission from the American Boat and Yacht Council (ABYC). To obtain the complete standard referenced or any other standards contact:*

*American Boat and Yacht Council: 3069 Solomon's Island Road  
Edgewater, MD 21037  
Telephone: 410.956.1050  
FAX: 410.456.2737*

*Variations of these wiring methods to permit use on a 120 volt 50 amp shoreline source or to utilize a reduced voltage output for 50 Hertz use are not shown on these ABYC diagrams. See Figure 8 and Figure 9 in the section, "Making 12KVA International Universal IsoTransformer Connections" for more information.*

Refer to the product labeling for additional wiring method information.

### Wired as an Isolation Transformer

The only difference between the two methods below is that in Method 2, a Ground Fault Protector (GFP) must be used instead of a circuit breaker, and the shore grounding conductor is not wired past the inlet of the boat. Method 1 is most commonly used.

*Note: This diagram does not illustrate a complete system. Refer to the appropriate ABYC text.*

Isolation Transformer System with Single-Phase 240-Volt Input, 120/240-Volt Single-Phase Output with Boat Grounded Secondary. Shield Grounded on Shore and Metal Case Grounded on Boat — The ungrounded shore current-carrying conductors are connected from the power inlet to the primary winding of the isolation transformer through an overcurrent protection device which simultaneously opens both current carrying conductors. Do not connect the shore neutral. Fuses shall not be used in lieu of simultaneous trip devices.

240-Volt branch circuit breakers and switches simultaneously open all current-carrying conductors.

120-Volt branch circuit breakers are permitted to use single-pole breakers in the ungrounded current-carrying conductors.

Polarization of conductors must be observed in all circuits.

The green grounding wire from the shore is connected to the shore power inlet shell which is insulated from metal-hulled boats. Do not connect the shore green wire to the boat ground.

The grounded neutral from the secondary of the isolation transformer and the case of the transformer are connected to the system ground, neutral conductor and engine negative terminal or its bus.

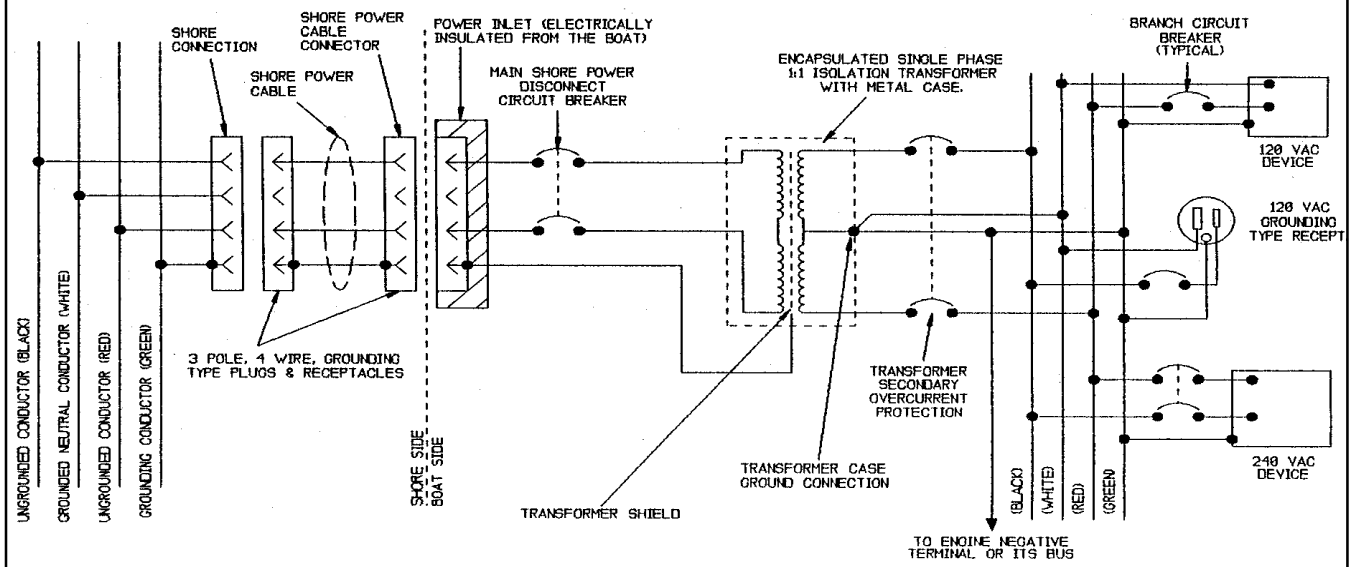

Figure 1. Electrical Diagram – Method 1 (see Figure 5 for Wiring Connections)

Note: This diagram does not illustrate a complete system. Refer to the appropriate ABYC text.

Isolation Transformer System with Single-Phase 240-Volt Input, 120/240-Volt Single-Phase Output, Ground Fault Protection and a Grounded Secondary. Shield and Metal Case Grounded on Boat — The ungrounded shore current-carrying conductors are connected from the power inlet to the primary winding of the isolation transformer through a ground fault protection device which simultaneously opens both current-carrying shore conductors. Fuses shall not be used in lieu of simultaneous trip devices.

240-Volt branch circuit breakers and switches simultaneously open all current-carrying conductors.

120-Volt branch circuit breakers are permitted to use single-pole breakers in the ungrounded current-carrying conductors.

Polarization of conductors must be observed in all circuits.

The green grounding wire from the shore power inlet is not connected to the to the isolation transformer shield or case nor to the boat ground.

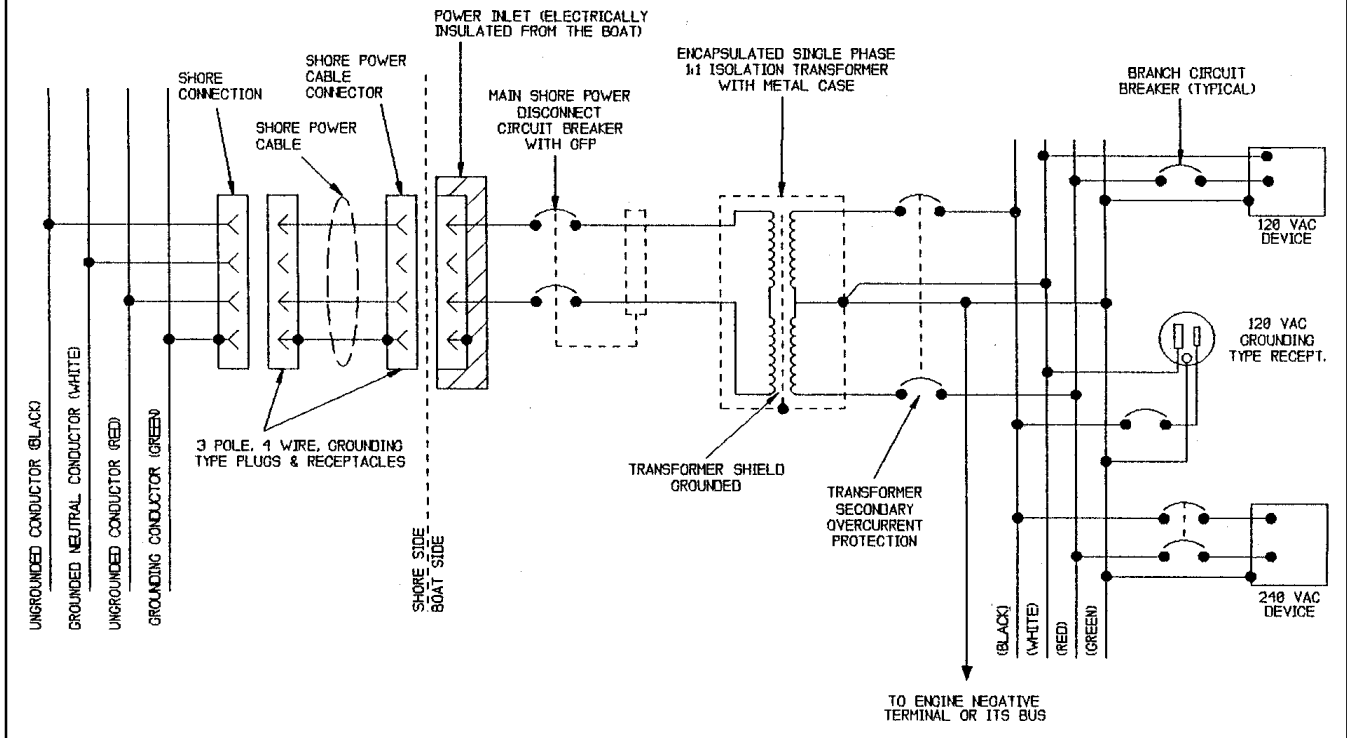
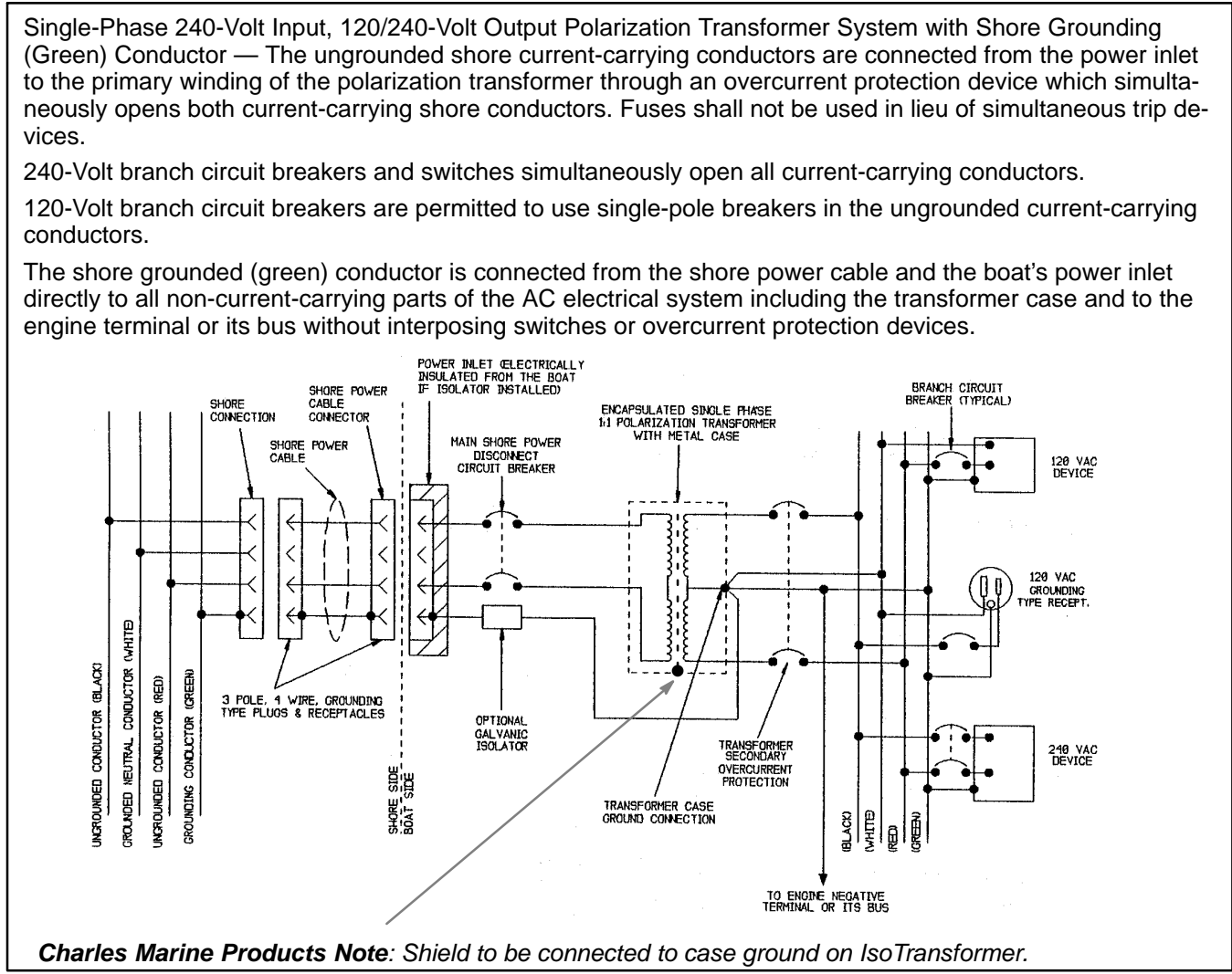

Figure 2. Electrical Diagram – Method 2 (see Figure 6 for Wiring Connections)

**Wired as a Polarization Transformer**

In this method the shield and the shore grounding conductor are wired directly to the transformer neutral (N) and case ground (GND). An optional galvanic isolator is also shown in-line with the shoreline grounding wire.

*Note: This diagram does not illustrate a complete system. Refer to the appropriate ABYC text.*



**Figure 3. Electrical Diagram – Method 3 (see Figure 7 for Wiring Connections)**

**Choosing Mounting Location**

After selecting a wiring method, the mounting location must be chosen. Like any piece of transformer operated equipment, the 12 KVA International Universal IsoTransformer will produce a noticeable “hum” when it is energized, although not nearly as loud as non-encapsulated transformers. Consideration should be given to not mounting the 12 KVA International Universal IsoTransformer in or immediately adjacent to areas where you will prefer it quiet, such as sleeping quarters. Locations to avoid are under bunks or on the opposite side of an un-insulated bulkhead immediately adjacent to the head of a bunk. The 12 KVA International Universal IsoTransformer should be mounted either vertically on a bulkhead with the access panel at the bottom or horizontally on the deck in a protected area away from rain or spray. When mounted vertically the bottom must be at least 24 inches above the deck or other equipment to avoid damage from splash and to ensure adequate access to wiring connections. The unit must be mounted in a secure location capable of supporting the full weight of approximately 235 pounds. Proper ventilation around the case is important. Allow at least six inches on all four sides of the unit for air circulation and cooling. During normal operation the case of the 12 KVA International Universal IsoTransformer may reach high temperatures. To avoid burns locate the 12 KVA International Universal IsoTransformer in an area where persons will not come in contact with the unit.



Four 1/2-inch holes, 1-inch from each end of the 12 KVA International Universal IsoTransformer have been provided for rigging and hoisting the unit (Figure 4). Typically, shackles are used for hoisting.

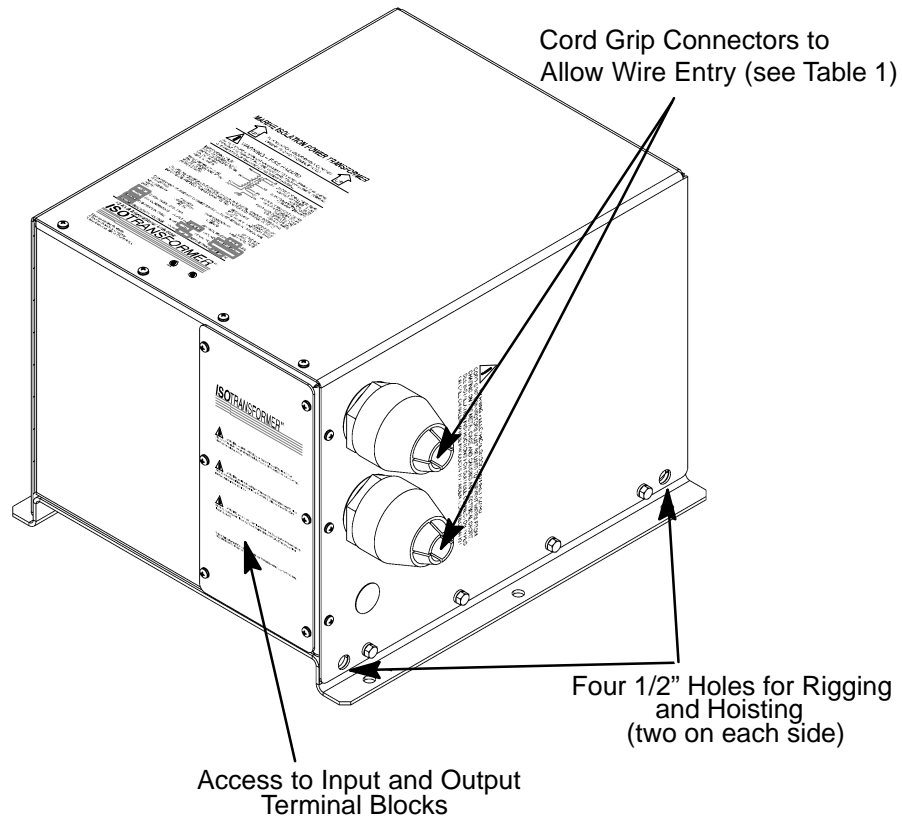

**Figure 4. 12 KVA International Universal IsoTransformer Access Openings**

### **WARNING – FIRE HAZARD**

**Do not store equipment on or next to transformer. This unit is designed to operate hot and must have free air flow to prevent overheating or charring of adjacent materials.**

#### **Choosing Mounting Hardware**

As with any marine equipment, secure mounting is of utmost importance. You will need to provide six bolts or screws to secure the unit. They must be 3/8-inches diameter. The screws or bolts you choose should be backed with a flat washer and kept vibration free with a split-ring lock washer. If using bolts, they must be secured on both sides of the bulkhead and also backed with a washer or washer plate. If using screws, they should be at least 1-inch long. All hardware must be corrosion-resistant stainless steel or cadmium-plated steel.

**Mounting the IsoTransformer**

The 12 KVA International Universal IsoTransformer may be mounted horizontally on a deck or vertically on a bulkhead.

**CAUTION**

**Use appropriate equipment to hoist and rig unit. Care should be taken to ensure safety of individuals.**

*Horizontal Mount*

**WARNING – ELECTRICAL SHOCK HAZARD**

**Use care when drilling to avoid contact with any wires or live components.**

Step	Action
1.	Carefully lower and position the 12 KVA International Universal IsoTransformer on the deck in the exact location the unit will be installed. <i>Note: The wiring enclosure should be visible and accessible.</i>
2.	Mark the six mounting holes using the IsoTransformer as a template.
3.	Remove the IsoTransformer and drill the six marked holes with the proper-sized drill bit.
4.	Realign the 12 KVA International Universal IsoTransformer’s mounting holes with the drilled holes and fasten the unit to the deck with the appropriate mounting hardware.
5.	Firmly secure all mounting hardware.

*Vertical Mount*

**WARNING – ELECTRICAL SHOCK HAZARD**

**Use care when drilling to avoid contact with any wires or live components.**

Step	Action
1.	Carefully lower and position the 12 KVA International Universal IsoTransformer on the bulkhead in the exact location the unit will be installed. <i>Note: The wiring compartment should be at the bottom to ensure proper cooling of the unit.</i>
2.	Mark the six mounting holes using the IsoTransformer as a template.
3.	Remove the IsoTransformer and drill the six marked holes with the proper-sized drill bit.
4.	Realign the 12 KVA International Universal IsoTransformer’s mounting holes with the drilled holes and fasten the unit to the bulkhead with the appropriate mounting hardware.
5.	Firmly secure all mounting hardware.

**Choosing the Appropriate Wire Type and Gauge**

All input and output conductors should be at least 6 AWG, stranded, 600 volt rating, UL type AWM, UL 1426 or equivalent, or a UL listed marine shore power cable. See ABYC standard E-11 for more details on conductor types and sizing (gauge).

**Choosing Electrical Wiring Hardware**

The usual application for the 12 KVA International Universal IsoTransformer is as an isolation transformer. In this application, there is no fault current path for the wiring from the shore power inlet to the 12 KVA International Universal IsoTransformer input connections. For this reason, the wiring should only be done with a jacketed cable (.030 inches jacket thickness minimum) such as UL type 1426 boat cable or by using a UL listed marine cable set wire (type SO or equivalent). This wiring should be installed in the boat in a protected area and routed to avoid contact with sharp edges or hot surfaces.

**WARNING – ELECTRICAL SHOCK HAZARD AND FIRE HAZARD**

**Cord grip connectors must be used to prevent wires from chafing on the metal case and causing an electrical short. See installation instructions for suitable connector types or call Charles Marine Products to order a connector kit.**

The 12 KVA International Universal IsoTransformer is intended for hard-wiring in a permanent location. Cord grip connectors with water sealing bushings and strain relief are required to secure wires or cables going into or out of the 12 KVA International Universal IsoTransformer.

Table 1 lists the parts approved by Charles Marine Products for use with the 12 KVA International Universal IsoTransformer.

**Table 1. Recommended Cord Grip Connectors and Accessories**

Description*	Cord Type	Manufacturer	Catalog Number	Sealing Washer	Locknut
Cord Range .472–.787	6/3 Boat Cable	Heyco	8443	3263	LN 1-1/4
Cord Range .510–.790	6/3 Boat Cable	Remke	RD29LR	SOR-4	LN 125
Cord Range .709–1.000	6/4 Boat Cable	Heyco	8441	3263	LN 1-1/4
Cord Range .700–.980	6/4 Boat Cable	Remke	RD29LA	SOR-4	LN 125
Cord Range .890–1.090	6/4 Boat Cable or 6/3 Cordset	Thomas & Betts	2702	5265	144
Cord Range 1.080–1.280	6/4 Cordset	Thomas & Betts	2703	5265	144

\*All connectors have a 1 1/4-inch hub size and are straight connectors

**Overcurrent Protection**

Overcurrent protection must be provided at the time of installation by circuit breakers on both the primary (shore) and secondary (boat) circuits. A two-pole circuit breaker is required for both the shore power line going into the 12 KVA International Universal IsoTransformer and the output line going to the boat's AC electrical system. These should be rated at 50 amps, 120/240 volts, 5000 Ampere Interrupting Capacity (AIC) and be of the long time delay type.

A Ground Fault Protector (GFP) is necessary if a shore grounding conductor is not used. Refer to Figure 2. This should be rated at 20 milli-amperes or less and if combined with the primary (shoreline) circuit breaker, should be rated at 50 amps, 120/240 volts, 5000 AIC and be of the long time delay type.

**Making 12 KVA International Universal IsoTransformer Connections****WARNING – HIGH VOLTAGE**

**To avoid serious injury or death from high voltage electrical shock disconnect AC shore power before opening panel.**

The wiring installation will depend on the method chosen in the section titled *Choosing an Electrical Wiring Method*. Follow the procedure below to make the appropriate connections.

Step	Action
1.	Remove the terminal access cover.
2.	Install the cord grip connectors using the sealing gaskets and locknuts.
3.	Undo the chucks from the cord grip connectors.
4.	Slide the cord grip connectors down and over the cables from the primary (shore power) and to the secondary (boat) circuit breakers.
5.	Insert the cables through the cord grip connectors and cut to length.
6.	Strip back the insulation.

Step	Action
7.	Crimp UL Recognized ring or captive spade terminals on all wires using an appropriate tool.
8.	Connect all wiring as shown in Figure 5, Figure 6, Figure 7, Figure 8 or Figure 9 based on the chosen wiring method.
9.	Tighten the cord grip connectors.
10.	Reinstall the terminal access cover.

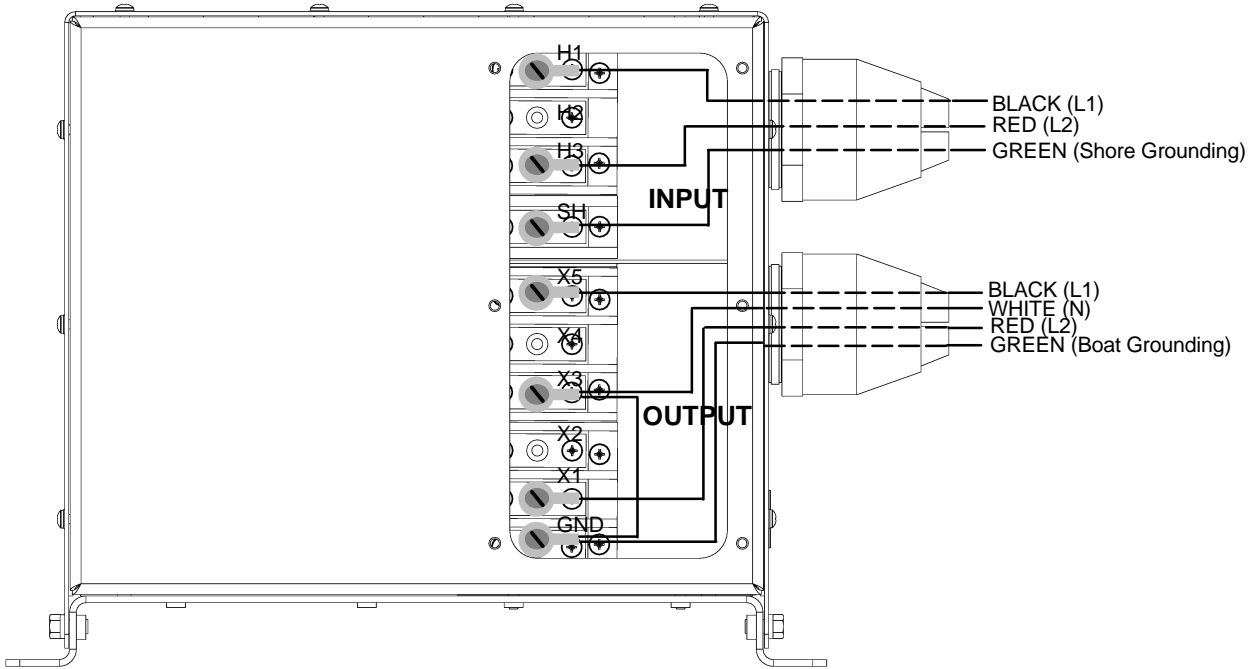

**Figure 5. Typical Wiring as an Isolation Transformer (240 Volt Primary Input) – Method 1 (see Figure 1 for Electrical Diagram)**

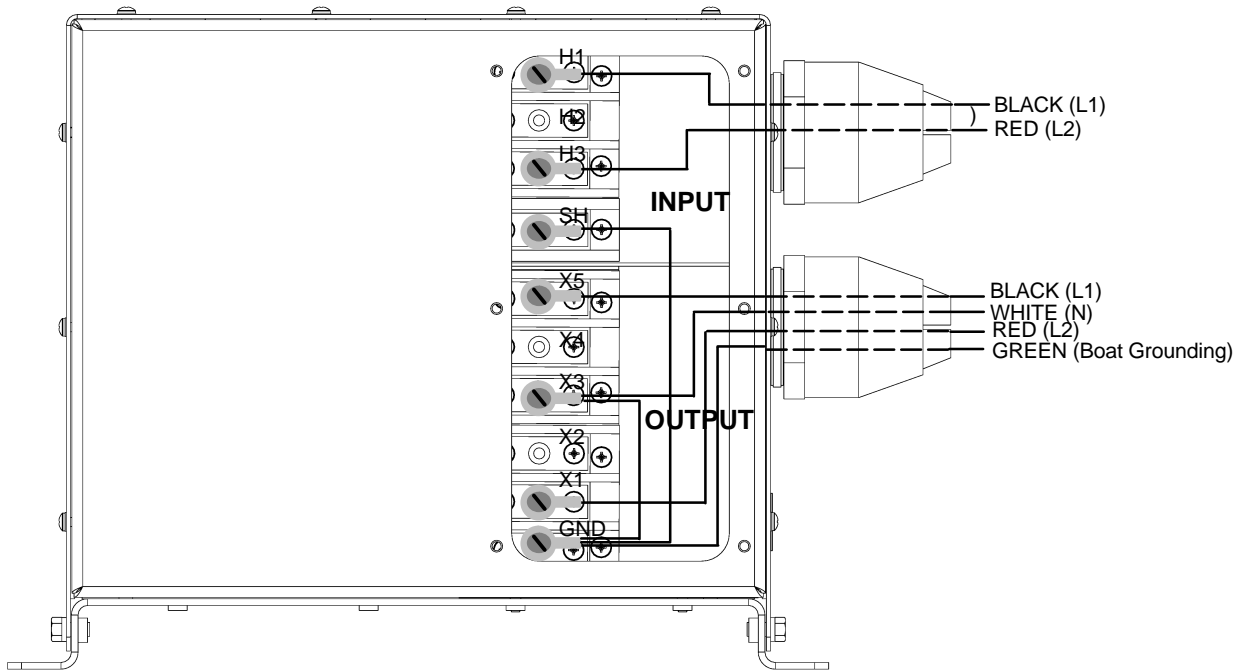

**Figure 6. Typical Wiring as an Isolation Transformer (240 Volt Primary Input) with Primary Ground Fault Protection – Method 2 (see Figure 2 for Electrical Diagram)**

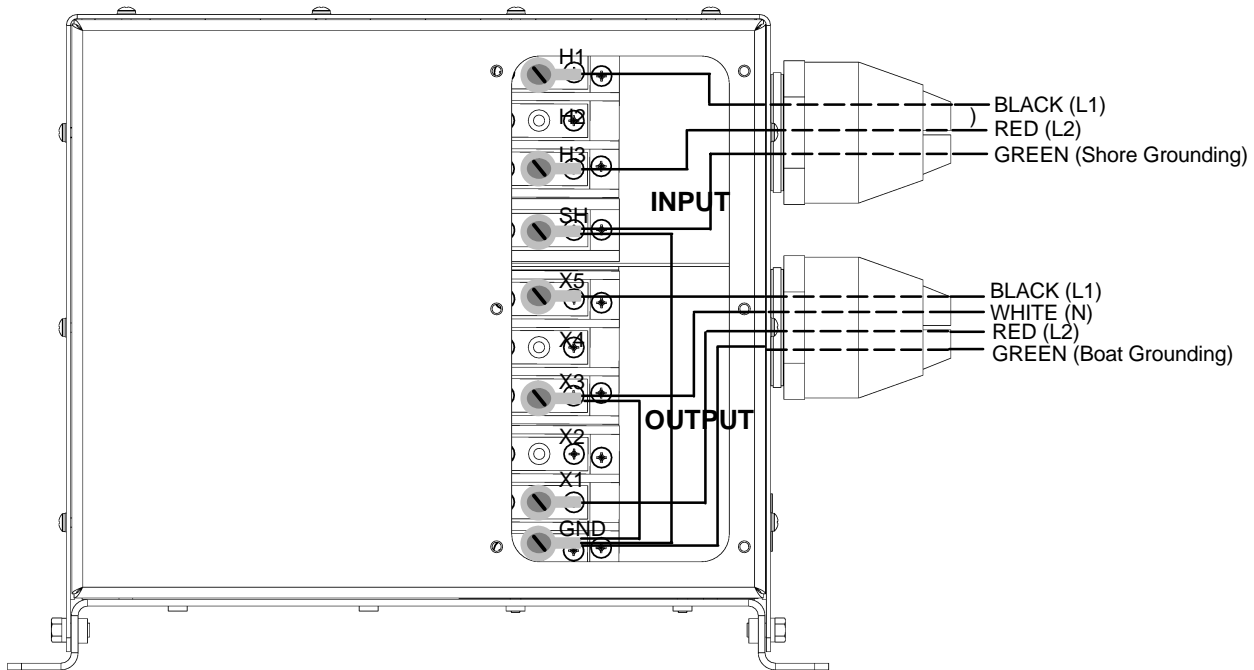

**Figure 7. Typical Wiring as a Polarization Transformer (240 Volt Primary Input) – Method 3 (see Figure 3 for Electrical Diagram)**

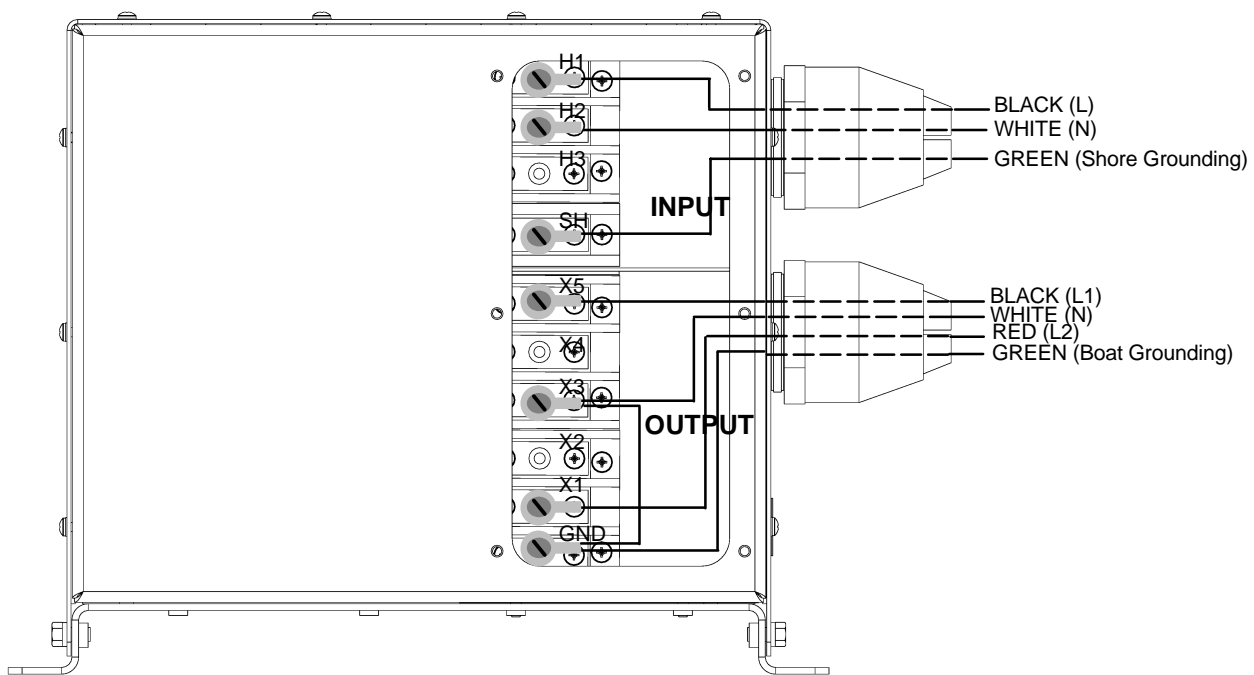

**Figure 8. Typical Wiring as an Isolation Transformer (120 Volt Primary Input) (Similar to Method 1, Figure 1 except with a 120 Volt two-pole input circuit breaker.)**

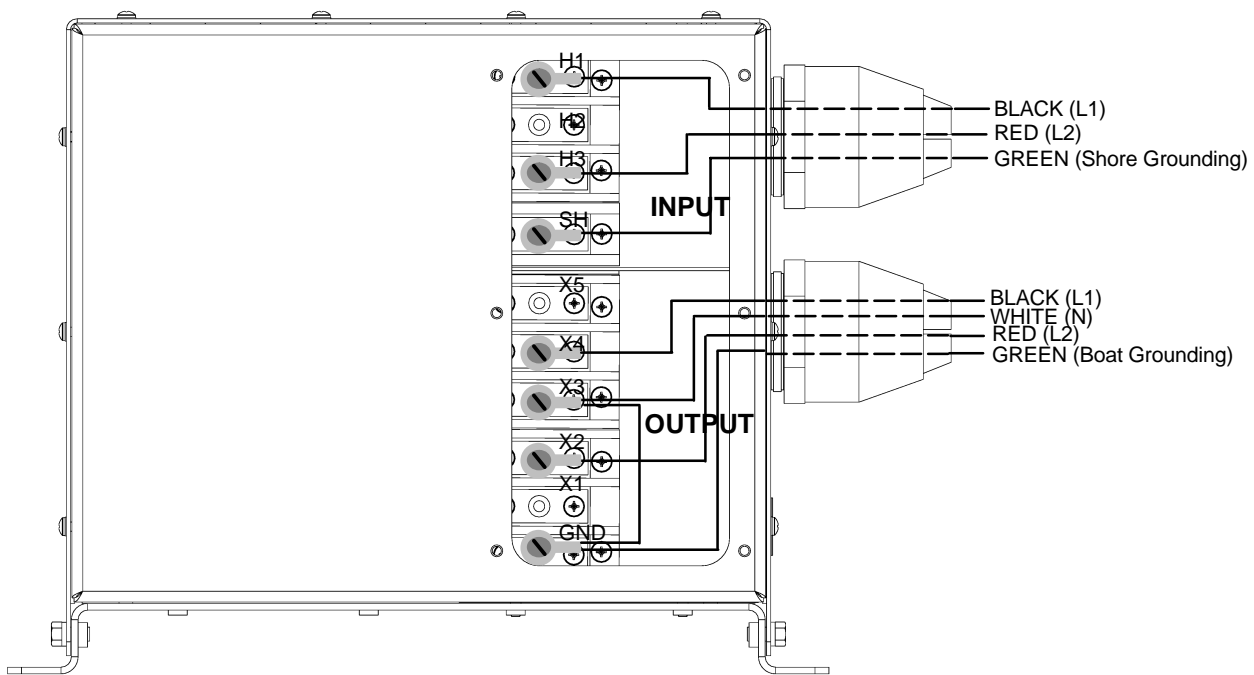

**Figure 9. Typical Wiring as an Isolation Transformer (240 Volt Primary Input) with 104/208 Volt Secondary Output (similar to Method 1, Figure 1 except with reduced voltage output for 50 Hertz use.)**

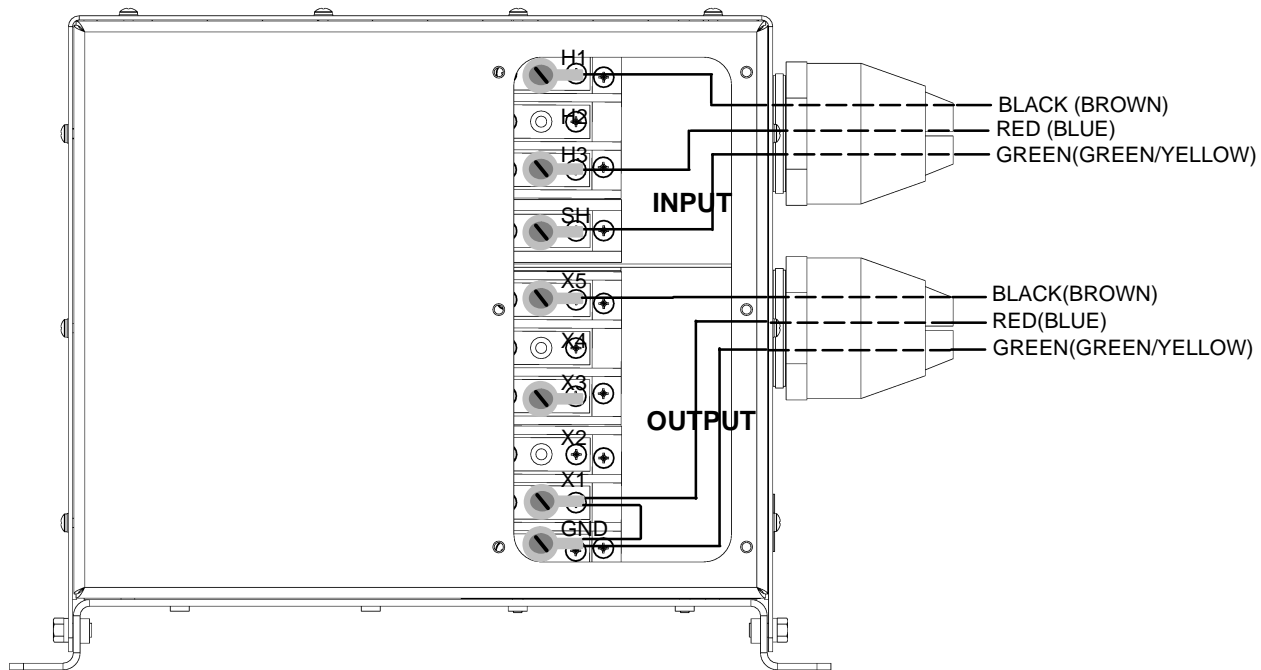

Figure 10. Typical Wiring for European 3-Wire, single-phase 230 Volt.

### Securing Covers

After all connections and terminations have been made, the terminal access cover should be re-installed using all hardware supplied.

### Applying Power

Power should only be applied after all connections and terminations have been made and the terminal access cover is secure. Plug in the shore power and turn on the appropriate circuit breakers to apply power. Refer to the section on *Proper Operation*.

## OPERATING THE ISOTRANSFORMER

### Safety First

Follow all precautions in the *IMPORTANT SAFETY INSTRUCTIONS* section in this manual. Pay close attention to the DANGER, WARNING and CAUTION boxes both within this manual and labeled on the unit.

### Proper Operation

When properly installed and connected, the 12 KVA International Universal IsoTransformer will provide isolation between shore and boat power while maintaining a one to one turns ratio (shore voltage equals boat voltage). The unit will also provide a one to two turns ratio to provide 120/240 volt power on board even though only 120 volt power is available on the dock. Taps on the secondary winding provide reduced voltage output to permit satisfactory operation of most 60 hertz equipment on 50 hertz.

## MAINTAINING THE ISOTRANSFORMER

### **WARNING – HIGH VOLTAGE**

**To avoid serious injury or death from high voltage electrical shock, disconnect the AC shore power before attempting any maintenance or cleaning.**

No adjustment or maintenance is required for the 12 KVA International Universal IsoTransformer other than periodic cleaning of the outside cabinet with a dry cloth and inspecting all connections for tightness and corrosion by a qualified service person.

## TROUBLESHOOTING

If there is a problem with the 12 KVA International Universal IsoTransformer, first check that all connections are accurate and secure, and retest. If all connections are good, contact Charles Marine Products for technical assistance.

## WARRANTY & CUSTOMER SERVICE

### Warranty

The CHARLES Marine & Industrial Group warrants the unit will be free from defects in materials and workmanship that cause mechanical failure for one (1) year, as set forth in the Limited Warranty. Notice of any alleged defect in material or workmanship must be provided within thirty (30) days of discovering the problem, and within the warranty period. Follow the procedure outlined below to obtain warranty service.

### Service Center and Repair Correspondence

*Note: Do not attempt to service the unit. Contact the Service Center.*

To contact the Service Center via telephone directly:

800-830-6523 (Toll Free)

217-932-2317 (Voice)

217-932-2473 (FAX)

Call to obtain a Returned Materials Authorization (RMA) number prior to returning any unit to Charles Industries.

Return the unit for repairs to the Service & Repair Center address below:

Charles Industries, Ltd.  
Marine & Industrial Group  
503 NE 15th Street  
Casey, IL 62420-2054  
USA

Correspondence can be sent to Corporate Headquarters via the address below:

*Note: Do not return the unit to this address.*

Charles Industries, Ltd.  
Marine & Industrial Group  
5600 Apollo Drive  
Rolling Meadows, IL 60008-4049  
USA  
847-806-6300  
www.charlesindustries.com

## SPECIFICATIONS

The specifications for the 12 KVA International Universal IsoTransformer are listed in Table 2.



**Table 2. 12 KVA International Universal IsoTransformer Specifications**

<b>Feature</b>	<b>Specification</b>
Input Voltage	120/240 VAC
Input Current	50 Amps
Output Voltage	120/240 VAC or 104/208 VAC
Output Current	50 Amps
KVA Continuous	12.0 KVA
Operating Frequency	50/60 Hertz
°C Rise Insulation System 220A	120° C
Insulation Class	H
% Impedance	3.00
Operating Temperature	0° to 50° C
Approximate Weight	235 pounds
Height	16 inches
Width	18.15 inches
Width (excluding the mounting flange)	15.15 inches
Depth	11.75 inches

## PRODUCT LABELING

The 12 KVA International Universal IsoTransformer is labeled as shown in Figure 11. The product label contains information unique to the purchased unit.

# MARINE ISOLATION POWER TRANSFORMER



UP

FOR VERTICAL (BULKHEAD) MOUNTING  
ORIENT IN DIRECTION INDICATED



UP

---



## WARNING - FIRE HAZARD

DO NOT STORE EQUIPMENT ON OR NEXT TO TRANSFORMER. THIS UNIT IS DESIGNED TO OPERATE HOT AND MUST HAVE FREE AIR FLOW TO PREVENT OVER HEATING OF CHARRING OF ADJACENT MATERIAL.

---

**INPUT CONNECTION**  
 INPUT BETWEEN H1 - H3  
 SHORE GROUNDING TO SH  
 VOLTS 240 VAC  
 AMPS 50 AMPS

INPUT BETWEEN H1-H2  
 SHORE GROUNDING TO SH  
 VOLTS 120 VAC  
 AMPS 50 AMPS

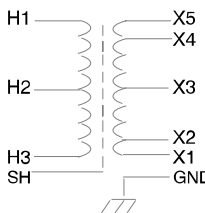

**OUTPUT CONNECTION (60 Hz)**  
 OUTPUT BETWEEN 1 - X5  
 NUETRAL TO X3  
 BOAT GROUNDING TO GND  
 120/240VAC / 50AMPS

**OUTPUT CONNECTION (50 Hz)**  
 OUTPUT BETWEEN X2-X4  
 NUETRAL TO X3  
 BOAT GROUNDING TO GND  
 VOLTS 104/208 VAC  
 AMPS 50 AMPS

TO USE AN AMERICAN ELECTRICAL SYSTEM IN EUROPE WITHOUT DECREASING THE LIFE OF FRACTIONAL HORSEPOWER INDUCTION MOTORS DUE TO 50 HZ INPUT MAKE THE FOLLOWING CONNECTIONS:

	SECONDARY VOLTS 50 HZ 104/208	SECONDARY CONNECTIONS LINE X2-X4, N-X3
--	----------------------------------	---

PRIMARY AND SECONDARY CONNECTIONS CAN BE REVERSED TO ACHIVE THE FOLLOWING:

NEW PRIMARY VOLTS	PRIMARY CONNECTION	NEW SECONDARY VOLTS	SECONDARY CONNECTIONS
208V	X2, X4	120/240V	LINE H1-H3, N-H2

C RISE INSUL. SYS. 220A

KVA CONTINUOUS

PRIMARY VOLTAGE

SECONDARY VOLTAGE

UL FILE NO.

% IMP.

CLASS

APPROX. WEIGHT  LBS.

CAT. NO.

SERIAL NO.

SINGLE PHASE  HZ

**12 KVA International Universal**

# ISOTRANSFORMER™

---



---



---

**Charles Marine Products**  
 A Charles Industries Company  
 Rolling Meadows, Illinois 60008 U.S.A.





Figure 11. 12 KVA International Universal IsoTransformer Product Specification Label

