

# DSM250 NMEA 2000® Multi-function Color Graphic Display

## User's Manual

Revision 1.4.2

Copyright © 2009 Maretron, LLP All Rights Reserved

Maretron, LLP  
9014 N. 23<sup>rd</sup> Ave #10  
Phoenix, AZ 85021-7850  
<http://www.maretron.com>

Maretron Manual Part #: M001301

# DSM250 User's Manual

---

## Revision History

Rev.	Description
1.0	Original document.
1.4.2	Added sections on Alert and Anchor Watch and configuration of more devices.

## Table of Contents

1	General.....	1
1.1	Introduction .....	1
1.2	Firmware Revision .....	1
1.3	DSM250 Features .....	1
1.4	Quick Install.....	1
2	Installation.....	2
2.1	Unpacking the Box .....	2
2.2	Choosing a Mounting Location .....	2
2.3	Mounting the DSM250.....	2
2.3.1	Surface Mounting the DSM250.....	2
2.3.2	Flush Mounting the DSM250 .....	3
2.3.3	Gimbal Mounting the DSM250.....	4
2.4	Connecting the DSM250 .....	5
2.4.1	Checking the Connection.....	5
3	Operating the DSM250 .....	6
3.1	Turning the DSM250 On .....	6
3.2	Turning the DSM250 Off .....	6
3.3	Keypad Essentials.....	7
3.3.1	Navigating in a Menu .....	7
3.3.2	Choosing a Value from a List.....	8
3.3.3	Entering a Numeric Value .....	8
3.3.4	Entering a Textual Value.....	8
4	Important Concepts .....	11
4.1	Favorite Screens .....	11
4.2	Categories and Data Types.....	11
4.2.1	AC Bus.....	11
4.2.2	AC Generator.....	11
4.2.3	AC Utility .....	12
4.2.4	Anchor Watch .....	12
4.2.5	DC.....	13
4.2.6	Depth .....	13
4.2.7	Engine.....	13
4.2.8	Environment.....	13
4.2.9	Fuel Management.....	15
4.2.10	GPS .....	15
4.2.11	Heading .....	16
4.2.12	Indicator .....	16
4.2.13	Navigation.....	16
4.2.14	Rudder .....	16
4.2.15	Special Devices .....	16
4.2.16	Speed .....	17
4.2.17	Tank.....	17
4.2.18	Temperature .....	18
4.2.19	Time.....	18
4.2.20	Transmission .....	18
4.2.21	Vessel .....	18
4.2.22	Wind.....	19

# DSM250 User's Manual

---

4.3	Alerts .....	20
4.3.1	Alert Types .....	20
4.3.2	Alert Terminology .....	20
4.3.3	Alert Priority .....	20
4.3.4	Vessel Alert Operating Modes .....	20
4.3.5	Alert States .....	22
4.3.6	Available Alert Classes .....	22
5	Operating Modes .....	24
5.1	Favorite screens modes .....	24
5.2	Menu Mode .....	24
5.2.1	Alert Setup Menu .....	26
5.2.2	Alert Status .....	26
5.2.3	Configuration Menu .....	26
5.2.4	Display Settings Menu .....	27
5.2.5	Favorite Screens Mode .....	35
5.2.6	Favorite Screens Setup Menu .....	35
5.2.7	Units Menu .....	40
6	Device Configuration .....	43
6.1	Bennett EP-30 (NMEA1) Trim Tabs Configuration .....	45
6.1.1	Trim Tabs Calibration .....	45
6.2	Maretron ACM100 Configuration .....	47
6.2.1	Advanced Configuration .....	47
6.2.2	AC Circuit Type .....	49
6.2.3	AC Device Type .....	50
6.2.4	Device Instance .....	50
6.2.5	Label .....	50
6.2.6	Reset Total Energy Recorded .....	50
6.3	Maretron ALM100 Configuration .....	52
6.3.1	Advanced Configuration .....	52
6.3.2	Instance .....	53
6.3.3	Label .....	53
6.3.4	Test Annunciator .....	54
6.4	Maretron DCM100 Configuration .....	55
6.4.1	Advanced Configuration .....	55
6.4.2	Current Sensor Zero Offset Calibration .....	57
6.4.3	DC Type .....	58
6.4.4	Instance .....	60
6.4.5	Label .....	60
6.5	Maretron DSM200 Configuration .....	61
6.5.1	Remote Device Selection .....	61
6.6	Maretron DSM250 Configuration .....	63
6.6.1	Remote Device Selection .....	63
6.6.2	Copy alarms settings from local display .....	64
6.6.3	Copy device selection from local display .....	65
6.6.4	Copy display settings from local display .....	65
6.6.5	Copy favorite settings from local display .....	65
6.6.6	Copy DST100 calibrations from local display .....	66
6.6.7	Copy all settings from local display .....	67

6.6.8	Label.....	67
6.6.9	Remote Device Selection.....	68
6.7	Maretron DST100 Configuration .....	69
6.7.1	Advanced Configuration.....	69
6.7.2	Clear Speed Calibration.....	70
6.7.3	Speed Calibration .....	70
6.7.4	Transducer Depth Offset.....	71
6.7.5	Trip Log.....	71
6.8	Maretron EMS100 Configuration .....	73
6.8.1	Engine Instance .....	73
6.8.2	Boost Pressure Gauge Type.....	73
6.8.3	Boost Pressure Sender Type.....	74
6.8.4	Boost Pressure Sender Offset .....	74
6.8.5	Drive Trim Gauge Type.....	74
6.8.6	Drive Trim Sender Type.....	74
6.8.7	Drive Trim Sender Offset .....	75
6.8.8	Oil Pressure Gauge Type .....	75
6.8.9	Oil Pressure Sender Type.....	75
6.8.10	Oil Pressure Sender Offset .....	75
6.8.11	Water Temperature Gauge Type .....	75
6.8.12	Water Temperature Sender Type .....	76
6.8.13	Water Temperature Sender Offset.....	76
6.8.14	Preset Engine Hours.....	76
6.8.15	Tachometer Flywheel Teeth .....	76
6.9	Maretron GPS100 Configuration .....	78
6.9.1	Advanced Configuration.....	78
6.9.2	Cold Start GPS .....	82
6.9.3	GPS Mode Setting .....	83
6.9.4	Device Label .....	84
6.9.5	SBAS (WAAS) Enable/Disable .....	84
6.10	Maretron J2K100 Configuration .....	85
6.10.1	Advanced Configuration.....	85
6.10.2	Device Label .....	87
6.10.3	Engine Instance .....	87
6.10.4	J1939 Source Address Configuration .....	88
6.10.5	Refresh J1939 source address list.....	89
6.10.6	Transmission Instance .....	89
6.11	Maretron RAA100 Configuration .....	91
6.11.1	Advanced Configuration.....	91
6.11.2	Label.....	92
6.11.3	Rudder Angle Calibration.....	93
6.11.4	Rudder Number .....	96
6.11.5	Operating Mode .....	97
6.11.6	Gauge Resistance, + to Sender.....	98
6.11.7	Gauge Resistance, - to Sender.....	98
6.12	Maretron RIM100 Configuration .....	100
6.12.1	Advanced Configuration.....	100
6.12.2	Device Label .....	101

# DSM250 User's Manual

---

6.12.3 Instance .....	102
6.12.4 Channel Configuration .....	102
6.13 Maretron SIM100 Configuration .....	103
6.13.1 Advanced Configuration.....	103
6.13.2 Device Label .....	104
6.13.3 Instance .....	105
6.13.4 Channel Configuration .....	105
6.14 Maretron SSC200 Configuration .....	106
6.14.1 Advanced Configuration.....	106
6.14.2 Installation Offset Calibration .....	109
6.14.3 Inverted Installation Entry .....	110
6.14.4 Label.....	111
6.14.5 Magnetic Deviation Calibration .....	111
6.14.6 Magnetic Deviation Status .....	112
6.14.7 Rate of Turn Damping Period .....	112
6.14.8 Rate of Turn Zero Offset Calibration .....	113
6.14.9 Variation Source Entry .....	113
6.15 Maretron TLA100 Configuration .....	117
6.15.1 Advanced Configuration.....	117
6.15.2 Label.....	118
6.15.3 Tank Capacity .....	118
6.15.4 Tank Levels Calibration .....	119
6.15.5 Tank Number .....	124
6.15.6 Tank Type.....	124
6.15.7 Operating Mode .....	125
6.15.8 Gauge Resistance, + to Sender.....	126
6.15.9 Gauge Resistance, - to Sender.....	126
6.16 Maretron TLM100 Configuration .....	128
6.16.1 Advanced Configuration.....	128
6.16.2 Label.....	129
6.16.3 Tank Capacity .....	129
6.16.4 Tank Levels Calibration .....	130
6.16.5 Tank Number .....	134
6.16.6 Tank Type.....	134
6.17 Maretron TLM150 Configuration .....	135
6.18 Maretron TLM200 Configuration .....	135
6.19 Maretron TMP100 Configuration .....	136
6.19.1 Advanced Configuration.....	136
6.19.2 Channel Configuration .....	137
6.19.3 Device Label .....	138
6.20 Maretron USB100 Configuration .....	139
6.20.1 Advanced Configuration.....	139
6.20.2 Remote Device Selection.....	140
6.21 Maretron WSO100 Configuration .....	142
6.21.1 Advanced Configuration.....	142
6.21.2 Device Label .....	144
6.21.3 Installation Offset Calibration .....	144
6.21.4 Wind Data Damping Period .....	146

6.21.5	Barometric Pressure .....	147
6.21.6	Outside Humidity.....	147
6.21.7	Outside Temperature.....	148
7	Data Display Types.....	149
7.1	Anchor Watch Display.....	149
7.2	Compass Rose Display.....	149
7.3	Gauge Display.....	150
7.4	GPS Status Display.....	152
7.5	Numeric Display.....	152
7.6	Rolling Road.....	153
7.7	Line Graph.....	154
7.8	Weather Display.....	155
7.9	Wind Rose.....	156
7.10	Moon Phase Display.....	156
7.11	Trim Tab Display.....	157
7.12	Swing Meter Display.....	157
7.13	Tank Gauge Display.....	158
8	Alerts.....	159
8.1	Displaying Active Alerts.....	159
8.1.1	Alert Status Screen.....	159
8.2	Accepting or Cancelling an Alert.....	160
8.2.1	From a Favorite Screen.....	160
8.2.2	From the Alert Status Screen.....	160
8.3	Adding an Alert.....	161
8.3.1	Enable/Disable Control.....	162
8.3.2	Alert Type.....	162
8.3.3	Priority.....	162
8.3.4	Trigger Source.....	163
8.3.5	Description.....	163
8.3.6	Location.....	163
8.3.7	Trigger Configuration.....	163
8.3.8	Local Audible.....	177
8.3.9	Tone.....	177
8.3.10	Remote Annunciators.....	178
8.3.11	Operating Mode Moored.....	178
8.3.12	Operating Mode Underway.....	178
8.3.13	Operating Mode Anchored.....	179
8.3.14	Scope.....	179
8.4	Deleting an Alert.....	179
8.5	Editing an Alert.....	180
8.6	Setting the Vessel Operating Mode.....	181
8.7	Advanced Configuration.....	182
8.7.1	Remote Alerts.....	183
8.7.2	Remote Alert Audible.....	183
8.7.3	Flashing Screen.....	183
8.8	Restore Factory Defaults.....	183
9	Maintenance.....	184
10	Troubleshooting.....	186

# DSM250 User's Manual

---

11	Technical Specifications .....	187
12	Technical Support.....	191
13	Installation Template.....	193
14	Maretron (2 Year) Limited Warranty .....	196



## Table of Figures

Figure 1 – Surface Mounting the DSM250 .....	3
Figure 2 – Flush Mounting the DSM250 .....	4
Figure 3 – Gimbal Mounting the DSM250 .....	5
Figure 4 – NMEA 2000® Connector Face View .....	5
Figure 5 – DSM250 Power Up Screen .....	6
Figure 6 – Powerdown Countdown Screen .....	7
Figure 7 – Keypad and Key Names .....	7
Figure 8 – Entering a Textual Value .....	9
Figure 9 – DSM250 Running in Favorite Screens Mode .....	24
Figure 10 – Main Menu .....	25
Figure 11 – Configuration Screen .....	26
Figure 12 – Device Selection Screen .....	27
Figure 13 – DSM250 Display Settings Screen .....	28
Figure 14 – DSM250 Advanced Configuration .....	28
Figure 15 – DSM250 Primary Device Selection .....	29
Figure 16 – DSM250 Advanced Information Screen .....	30
Figure 17 – Bus Status Display .....	30
Figure 18 – Backlight Menu .....	31
Figure 19 – Color Palette Selection Screen .....	32
Figure 20 – Color Palette Configuration Screen .....	32
Figure 21 – Setting the Demo Mode .....	33
Figure 22 – Setting the Keyboard Beep Option .....	34
Figure 23 – Editing the DSM250 Label .....	34
Figure 24 – Setting the Favorite Screens Mode .....	35
Figure 25 – Favorite Screens Setup Screen .....	35
Figure 26 – Favorite Screen Parameters .....	36
Figure 27 – Setting the Favorite Screen Format .....	37
Figure 28 – Setting the Auto Change Interval .....	37
Figure 29 – Selecting the Data Category .....	38
Figure 30 – Selecting the Data to be displayed .....	38
Figure 31 – DSM250 Units Menu .....	40
Figure 32 – Device Configuration Screen .....	44
Figure 33 – EP-30 Trim Tabs Configuration Screen .....	45
Figure 34 – EP-30 Trim Tabs Calibration Opening Screen .....	45
Figure 35 – EP-30 Intermediate Calibration Screen .....	46
Figure 36 – EP-30 Calibration Success Message .....	46
Figure 37 – ACM100 Configuration Screen .....	47
Figure 38 – ACM100 Advanced Configuration Screen .....	47
Figure 39 – ACM100 NMEA 2000® PGN Enable/Disable Screen .....	49
Figure 40 – Reset Total Energy Recorded Confirmation Screen .....	51
Figure 41 – ALM100 Configuration Screen .....	52
Figure 42 – ALM100 Advanced Configuration Screen .....	52
Figure 43 – ALM100 NMEA 2000® PGN Enable/Disable Screen .....	53
Figure 44 – DCM100 Configuration Screen .....	55
Figure 45 – DCM100 Advanced Configuration Screen .....	55
Figure 46 – DCM100 NMEA 2000® PGN Enable/Disable Screen .....	56

# DSM250 User's Manual

---

Figure 47 – Current Sensor Zero Offset Calibration Confirmation Screen .....	57
Figure 48 - Current Sensor Zero Offset Calibration Complete Screen .....	57
Figure 49 – DSM200 Remote Configuration Screen .....	61
Figure 50 – DSM200 Remote Device Selection Screen .....	61
Figure 51 – DSM250 Remote Configuration Screen .....	63
Figure 52 – DSM250 Remote Device Selection Screen .....	64
Figure 53 - DSM250 Copy alarms settings from local display .....	64
Figure 54 – DSM250 Copy device selection from local display .....	65
Figure 55 – DSM250 Copy favorite settings from local display .....	66
Figure 56 – Favorite Settings Transfer Completion Screen .....	66
Figure 57 – DST100 Configuration Screen .....	69
Figure 58 – DST100 Advanced Configuration Screen .....	69
Figure 59 – Calibrating the DSM250 for DST100 Speed through Water .....	70
Figure 60 – Setting the Transducer Depth Offset in a DST100 .....	71
Figure 61 – Resetting the DST100 Trip Distance Log .....	72
Figure 62 – EMS100 Configuration Screen .....	73
Figure 63 – GPS100 Configuration Screen .....	78
Figure 64 – GPS100 Advanced Configuration Screen .....	78
Figure 65 – Configuring Antenna Altitude on a GPS100 .....	79
Figure 66 – Configuring Satellite Elevation Mask on a GPS100 .....	80
Figure 67 – Configuring PDOP Mask on a GPS100 .....	80
Figure 68 – Configuring SNR Mask on a GPS100 .....	81
Figure 69 – GPS100 NMEA 2000® PGN Enable/Disable Screen .....	82
Figure 70 – Restoring Factory Defaults on the GPS100 .....	82
Figure 71 – Performing a Cold Start of the GPS100 .....	83
Figure 72 – Configuring GPS Operating Mode on a GPS100 .....	83
Figure 73 – Configuring SBAS on a GPS100 .....	84
Figure 74 – J2K100 Configuration Screen .....	85
Figure 75 – J2K100 Advanced Configuration Screen .....	85
Figure 76 – J1939 Diagnostic Messages Configuration .....	86
Figure 77 – J2K100 NMEA 2000® PGN Enable/Disable Screen .....	87
Figure 78 – J1939 Source Address Configuration .....	88
Figure 79 – NMEA2000 Transmission Instance Configuration .....	89
Figure 80 – RAA100 Configuration Screen .....	91
Figure 81 – RAA100 NMEA 2000® PGN Enable/Disable Screen .....	92
Figure 82 – Rudder Angle Calibration Options .....	93
Figure 83 – Custom Rudder Angle Calibration .....	94
Figure 84 – Starboard Rudder Angle Calibration .....	94
Figure 85 – Center Rudder Angle Calibration .....	95
Figure 86 – Port Rudder Angle Calibration .....	95
Figure 87 – Custom Rudder Calibration Confirmation Screen .....	96
Figure 88 – Setting the Rudder Number .....	97
Figure 89 – Setting the Operating Mode .....	97
Figure 90 – Setting the + to Sender Gauge Resistance .....	98
Figure 91 – Setting the – to Sender Gauge Resistance .....	99
Figure 92 – RIM100 Configuration Screen .....	100
Figure 93 – RIM100 Advanced Configuration Screen .....	100
Figure 94 – RIM100 NMEA 2000® PGN Enable/Disable Screen .....	101

Figure 95 – RIM100 Channel Configuration Screen .....	102
Figure 96 – SIM100 Configuration Screen .....	103
Figure 97 – SIM100 Advanced Configuration Screen .....	103
Figure 98 –SIM100 NMEA 2000® PGN Enable/Disable Screen .....	104
Figure 99 – SIM100 Channel Configuration Screen.....	105
Figure 100 –SSC200 Configuration Screen .....	106
Figure 101 –SSC200 Advanced Configuration Screen .....	106
Figure 102 –SSC200 NMEA 0183 Settings Screen .....	107
Figure 103 – SSC200 NMEA 0183 Sentence/Rate Selection Screen.....	108
Figure 104 – SSC200 Load Default Periodic Rate Selection .....	108
Figure 105 –SSC200 NMEA 2000® PGN Enable/Disable Screen .....	109
Figure 106 –SSC200 Installation Offset Calibration Screen .....	110
Figure 107 – Setting the Installation Orientation .....	110
Figure 108 –SSC200 Magnetic Deviation Calibration Start Screen .....	111
Figure 109 –SSC200 Magnetic Deviation Calibration Progress Screen .....	112
Figure 110 –SSC200 Magnetic Deviation Status Screen.....	112
Figure 111 – Programming SSC200 Rate of Turn Damping Period.....	113
Figure 112 –SSC200 Rate of Turn Zero Offset Calibration Screen .....	113
Figure 113 – Setting Variation Source to NMEA 0183 or NMEA 2000® (factory default) .....	114
Figure 114 – Setting Variation Source to NMEA 0183 Only.....	114
Figure 115 – Setting Variation Source to NMEA 2000® Only .....	115
Figure 116 – Entering Manual Variation.....	115
Figure 117 – TLA100 Configuration Screen.....	117
Figure 118 – TLA100 Advanced Configuration Screen.....	117
Figure 119 –TLA100 NMEA 2000® PGN Enable/Disable Screen .....	118
Figure 120 – Configuring the Tank Capacity .....	119
Figure 121 – Tank Capacity Change Confirmation Screen.....	119
Figure 122 – Performing Custom Calibration of the Tank Level Adapter .....	120
Figure 123 – Tank Levels Calibration Capacity Estimation .....	121
Figure 124 – Empty Level Calibration .....	121
Figure 125 – Intermediate Level Calibration .....	122
Figure 126 – Full Level Calibration .....	122
Figure 127 – Custom Tank Level Calibration Confirmation Screen .....	123
Figure 128 – American Standard Sender Calibration.....	123
Figure 129 – European Standard Sender Calibration .....	124
Figure 130 – Configuring the Tank Number .....	124
Figure 131 – Configuring the Tank Type.....	125
Figure 132 – Configuring the Operating Mode .....	126
Figure 133 – Configuring the + to Sender Gauge Resistance.....	126
Figure 134 – Configuring the - to Sender Gauge Resistance .....	127
Figure 135 – TLM100 Configuration Screen .....	128
Figure 136 – TLM100 Advanced Configuration Screen .....	128
Figure 137 – TLM100 NMEA 2000® PGN Enable/Disable Screen.....	129
Figure 138 – Configuring the Tank Capacity .....	130
Figure 139 – Tank Capacity Change Confirmation Screen.....	130
Figure 140 – Performing Custom Calibration of the Tank Level Monitor.....	131
Figure 141 – Tank Levels Calibration Capacity Estimation .....	131
Figure 142 – Empty Level Calibration .....	132

# DSM250 User's Manual

---

Figure 143 – Intermediate Level Calibration .....	132
Figure 144 – Full Level Calibration .....	133
Figure 145 – Custom Tank Level Calibration Confirmation Screen .....	133
Figure 146 – Rectangular Tank Selection .....	134
Figure 147- Rectangular Tank Calibration .....	134
Figure 148 – TMP100 Configuration Screen.....	136
Figure 149 – TMP100 Advanced Configuration Screen.....	136
Figure 150 – TMP100 NMEA 2000® PGN Enable/Disable Screen .....	137
Figure 151 – TMP100 Channel Configuration Screen .....	138
Figure 152 – USB100 Configuration Screen.....	139
Figure 153 – USB100 Advanced Configuration Screen.....	139
Figure 154 – USB100 Device Selection Screen.....	140
Figure 156 – WSO100 Advanced Configuration Screen.....	142
Figure 157 – WSO100 NMEA 2000® PGN Enable/Disable Screen .....	143
Figure 158 – WSO100 Installation Offset Screen .....	145
Figure 159 – WSO100 Configuration Aborted Due to Low Wind Speed .....	145
Figure 160 – Installation Offset Success Confirmation Screen .....	146
Figure 161 – Installation Offset Abort Confirmation Screen .....	146
Figure 162 – Setting the Wind Data Damping Period .....	147
Figure 163 – Setting the Barometric Pressure .....	147
Figure 164 – Setting the Outside Humidity .....	148
Figure 165 – Setting the Outside Temperature.....	148
Figure 166 – Anchor Watch Display Example.....	149
Figure 167 – Compass Rose Display (Course Up) Example .....	150
Figure 168 – Compass Rose (North Up) Display .....	150
Figure 169 – Gauge Display Example .....	151
Figure 170 – Rudder Angle Gauge Display Example.....	151
Figure 171 – GPS Status Display Example.....	152
Figure 172 – Numeric Display Example.....	153
Figure 173 – Configuration of Rolling Road Display .....	153
Figure 174 – Rolling Road Display.....	154
Figure 175 – Line Graph Display .....	155
Figure 176 – Weather Display.....	155
Figure 177 – Wind Rose Display.....	156
Figure 178 – Moon Phase Display .....	156
Figure 179 – Trim Tab Display.....	157
Figure 180 – Swing Meter Display .....	157
Figure 181 – Tank Gauge Display .....	158
Figure 182 – Alert Display.....	159
Figure 183 – Adding a New Alert .....	161
Figure 184 – Part of the Alert Edit Screen .....	162
Figure 185 – High Alert Parameters.....	164
Figure 186 – Trigger Configuration – High Alert.....	165
Figure 187 – Low Alert Parameters .....	166
Figure 188 - Trigger Configuration – Low Alert .....	167
Figure 189 – Trigger Configuration – Data Unavailable Alert.....	168
Figure 190 – Trigger Configuration – On Alert .....	169
Figure 191 – Trigger Configuration – Data Unavailable Alert.....	170

Figure 192 – Trigger Configuration Editor - Tripped Alert .....	170
Figure 193 – Outside Alert Parameters.....	171
Figure 194 - Trigger Configuration – Outside Radius Alert .....	172
Figure 195 – Trigger Configuration - Inside Radius Alert .....	173
Figure 196 – Trigger Configuration - GPS Quality Alert .....	174
Figure 197 – Direction Alert Parameters.....	175
Figure 198 – Trigger Configuration - Direction Alert.....	176
Figure 199 - Alert Editor - Time Alert .....	177
Figure 200 – Surface Mounting Template .....	193
Figure 201 – Flush Mounting Template .....	194



## 1 General

### 1.1 Introduction

Congratulations on your purchase of the Maretron DSM250 NMEA 2000® Multi-function Color Graphic Display. Maretron has designed and built your display to the highest standards for years of dependable and accurate service.

Maretron's DSM250 is a high-resolution color display that allows easy interpretation of NMEA 2000® instrument and navigation data through custom display configurations, with an easy-to-use five-key illuminated keypad.

The Maretron DSM250 is designed to operate within the harsh demands of the marine environment. However, no piece of marine electronic equipment can function properly unless installed, configured, and maintained in the correct manner. Please read carefully and follow these instructions for installation, configuration, and usage of the Maretron DSM250 in order to ensure optimal performance.

### 1.2 Firmware Revision

This manual corresponds to DSM250 firmware revision 1.4.2.

### 1.3 DSM250 Features

The Maretron DSM250 has the following features.

- NMEA 2000® Interface
- Waterproof NMEA 2000® Connector
- Sealed Waterproof Enclosure
- Powered Directly from NMEA 2000® Port
- Surface, Flush, or Gimbal Mounting
- Adjustable Multi-colored Backlighting of Screen and Keys Preserves Night Vision
- Visual and Audible Alarms
- 16 User Configurable Favorite Screens (Automatic or Manual Scrolling between Screens)
- Capable of Viewing Virtually all NMEA 2000® Information including Batteries, Engines, Generators, Shore Power, Tanks, Navigation, Weather and More

### 1.4 Quick Install

Installing the Maretron DSM250 display involves the following four steps. Please refer to the individual sections for additional details.

- Unpack the Box (Section 2.1)
- Choose a Mounting Location (Section 2.2)
- Mount the DSM250 (Section 2.3)
- Connect the DSM250 (Section 2.4)

## 2 Installation

### 2.1 Unpacking the Box

When unpacking the box containing the Maretron DSM250, you should find the following items:

- 1 – DSM250 NMEA 2000® Multi-function Graphic Display
- 4 – Mounting studs
- 4 – Mounting washers
- 4 – Mounting lock washers
- 4 – Mounting knurled nuts
- 1 – DSM250 User's Manual
- 1 – Warranty Registration Card

If any of these items are missing or damaged, please contact Maretron.

### 2.2 Choosing a Mounting Location

The DSM250 is housed in a waterproof enclosure (IEC IP67 rating – protected against the effects of temporary immersion in water) and can be mounted in either an outdoor location or an indoor location.

### 2.3 Mounting the DSM250

The DSM250 has three mounting options, which includes surface mounting, flush mounting, or an optional gimbal mounting. Maretron suggests a location at which the display can be viewed from a relatively straight angle, and at which the keys are easily pressed.

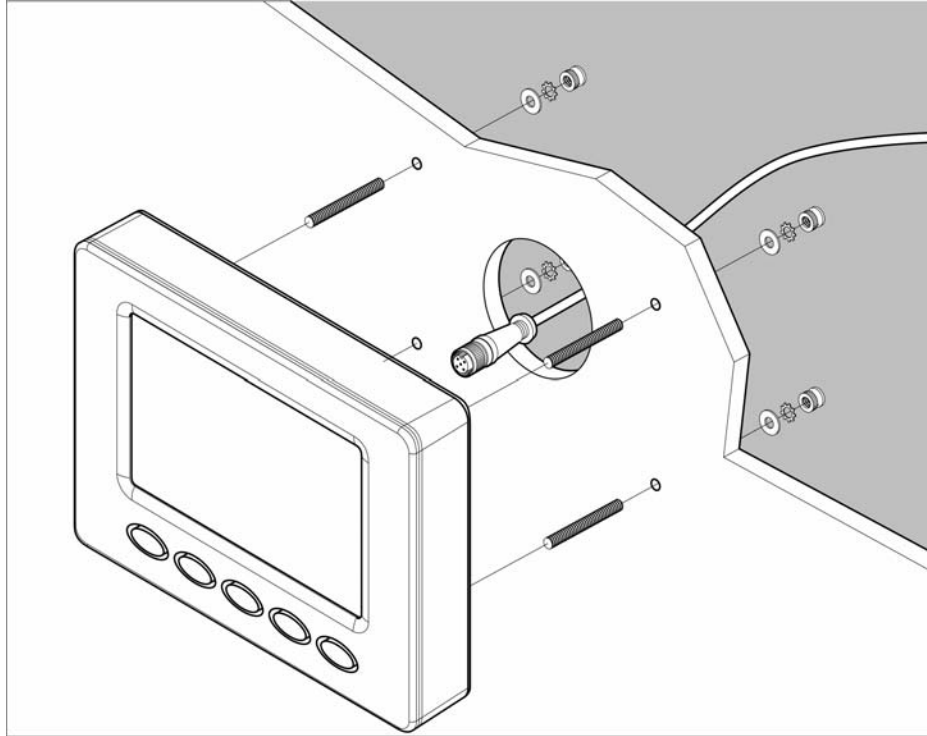
#### 2.3.1 Surface Mounting the DSM250

The DSM250 can be directly mounted to any suitable surface as shown in Figure 1. The steps for this type of mounting are as follows:

1. Attach the Surface Mount Template (see Section 13) to the surface where the DSM250 is to be located.
  - a. Make sure the template is level by using one of the horizontal lines as a guide.
  - b. Scotch tape works well for securing the template.
  - c. The maximum thickness of the mounting material should not exceed 1¼" using the provided mounting studs, thicker surfaces can be accommodated but you will need to purchase longer studs.
2. Drill the four mounting holes all the way through the mounting surface at the locations indicated on the *Surface Mount Template*.
  - a. Use a 3/16" drill bit.
3. Drill or cut a single hole for the electrical connector.
  - a. Use a 2¼" hole saw.
  - b. You will probably want this hole to be large enough for your fingers so that you can connect or disconnect the cable without removing the DSM250.
4. Remove the template from the mounting surface.
5. Insert the 2" studs into the back of the DSM250.



- a. Make sure the studs are fully inserted into the back of the DSM250 but don't over tighten the studs.
6. Insert the studs protruding from the back of the DSM250 through the mounting holes and secure with the provided hardware.
  - a. Place the flat washer on the stud first followed by the lock washer followed by the knurled nut.
  - b. Hand-tighten the knurled nut.



**Figure 1 – Surface Mounting the DSM250**

### 2.3.2 Flush Mounting the DSM250

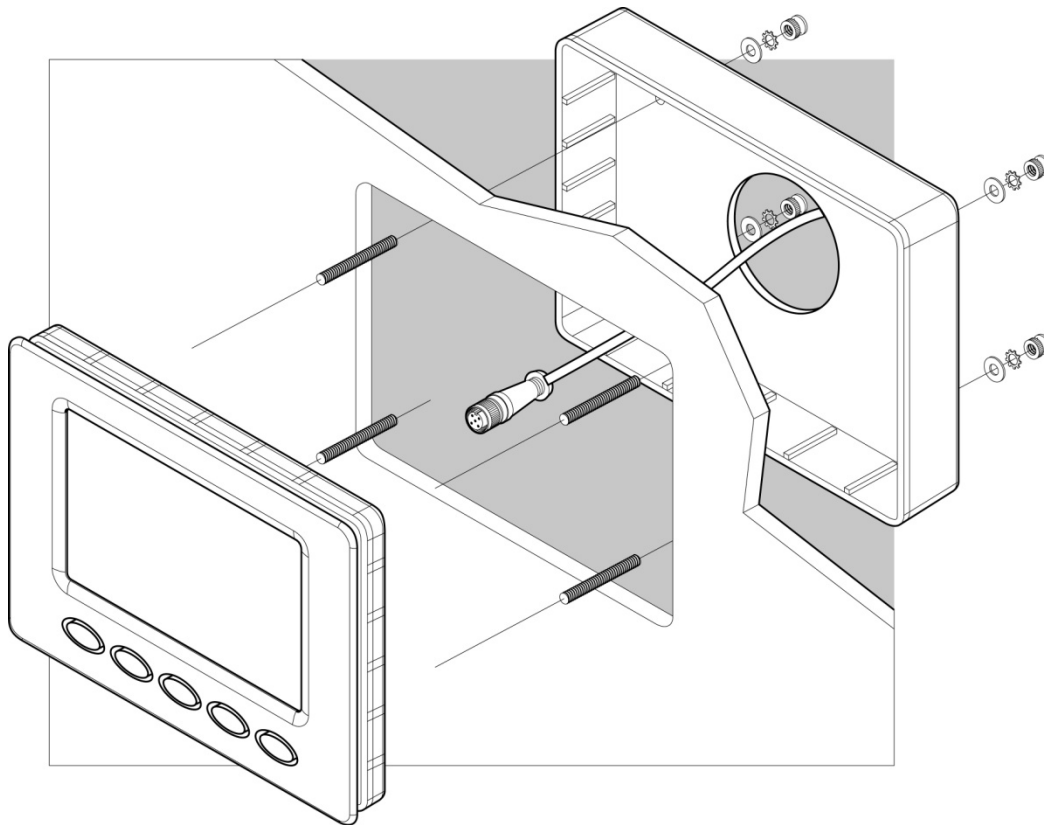
The DSM250 can be flush mounted to any suitable surface as shown in Figure 2. The steps for this type of mounting are as follows:

1. Attach the *Flush Mount Template* (see Section 13) to the surface where the DSM250 is to be located.
  - a. Make sure the template is level by using one of the horizontal lines as a guide.
  - b. Scotch tape works well for securing the template.
  - c. The maximum thickness of the mounting material should not exceed 1¼" using the provided mounting studs, thicker surfaces can be accommodated but you will need to purchase longer studs.
2. Cut out an opening as indicated on the *Flush Mount Template*.
  - a. Sorry, we should have made the flange larger, but be very careful not to go outside the indicated cutout area. Be on the safe side and cut the hole a little small and rasp or file to fit.
3. Remove the template from the mounting surface.
4. Insert the 2" studs into the back of the DSM250.
  - a. Make sure the studs are fully inserted into the back of the DSM250 but don't over tighten the studs.
5. Remove the back of the case from the DSM250.

# DSM250 User's Manual

---

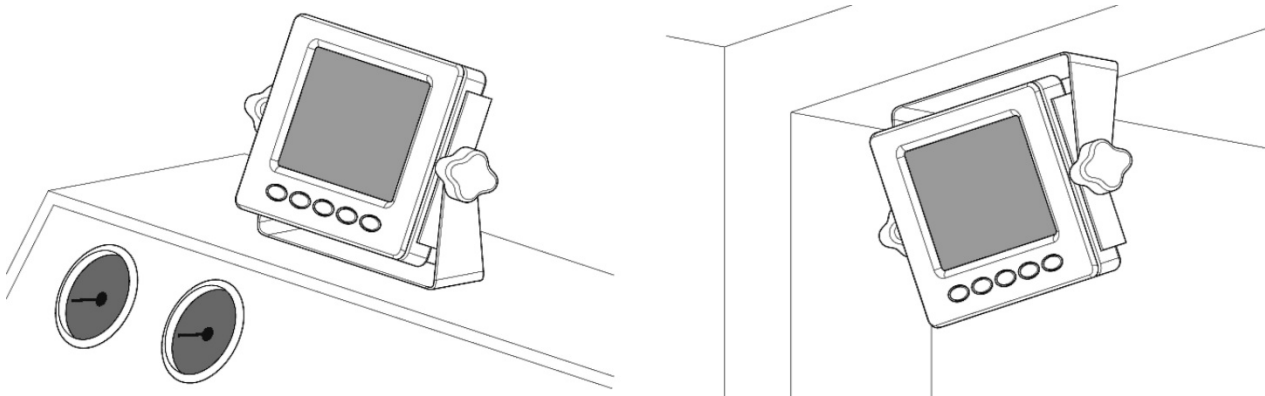
- a. Place your thumbs on top of the studs and your finger along the side of the case and squeeze the back cover off the DSM250.
6. Insert the back of the DSM250 through the front side of the cutout.
7. Place the back cover on the opposite side of the mounting surface with the mounting holes aligned with the mounting studs and secure with the supplied hardware.
  - a. Place the flat washer on the stud first followed by the lock washer followed by the knurled nut.
  - b. Hand tighten the knurled nut.



**Figure 2 – Flush Mounting the DSM250**

## 2.3.3 Gimbal Mounting the DSM250

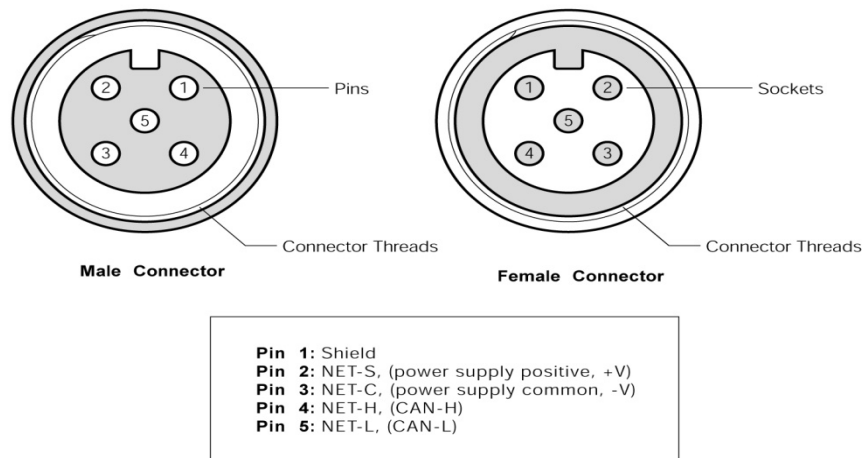
The DSM250 can be gimbal mounted to any horizontal surface such a counter or ceiling as shown in Figure 3. The optional gimbal mounting assembly (part number DSMMNTASSBLY) includes a bracket and screws for attaching the bracket to the DSM250, a stand, and 2 knobs for fastening the DSM250/bracket to the stand.



**Figure 3 – Gimbal Mounting the DSM250**

## 2.4 Connecting the DSM250

The Maretron DSM250 provides a connection to an NMEA 2000® interface through a connector that can be found on the back of the unit. The NMEA 2000® connector is a five pin male connector (see Figure 4). You connect the DSM250 to an NMEA 2000® network using a Maretron NMEA 2000® cable (or compatible cable) by connecting the female end of the cable to the DSM250 (note the key on the male connector and keyway on the female connector). Be sure the cable is connected securely and that the collar on the cable connector is tightened firmly. Connect the other end of the cable (male) to the NMEA 2000® network in the same manner. The DSM250 is designed such that you can plug or unplug it from an NMEA 2000® network while the power to the network is connected or disconnected. Please follow recommended practices for installing NMEA 2000® network products.




**Figure 4 – NMEA 2000® Connector Face View**

### 2.4.1 Checking the Connection

Once the NMEA 2000® connection to the Maretron DSM250 has been completed, observe the display to check to see that information is being properly received. One way to verify connectivity is to enter the device selection menu, which is described in Section 5.2.3.2. Refer to Section 10, “Troubleshooting”, if no information appears.

## 3 Operating the DSM250

### 3.1 Turning the DSM250 On

To turn on the DSM250, press the power key (the leftmost of the five keys on the keypad). The DSM250 will display a warning and ask you to press the Accept key (  ) to acknowledge the warning and continue operation of the DSM250 (see Figure 5 below).



*Figure 5 – DSM250 Power Up Screen*

Alternatively, you may power down the DSM250 by pressing and holding the power key (see Section 3.2 below for details).

### 3.2 Turning the DSM250 Off

To turn the DSM250 off, press and hold the power key. The DSM250 will display a countdown screen, which can be seen in Figure 6. If you continue to hold the power key, the DSM250 will power down in approximately three seconds. If you release the power key before these three seconds have elapsed, the DSM250 will return to its current operational state.

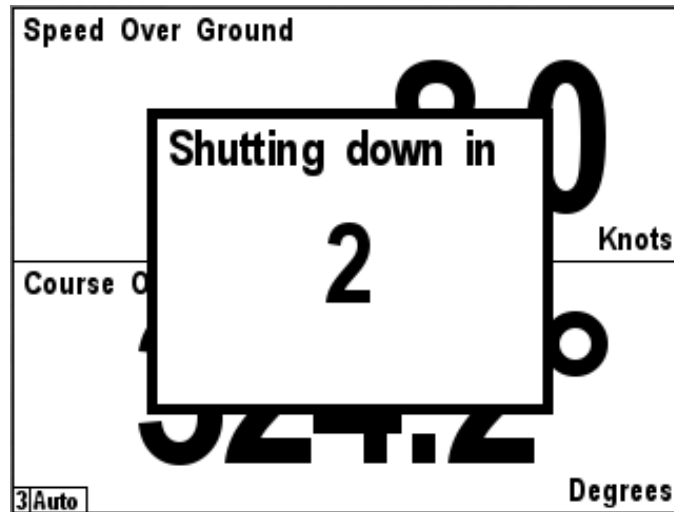


Figure 6 – Powerdown Countdown Screen

## 3.3 Keypad Essentials

The DSM250 has a five-key keypad located below the screen. Each key has slightly different functions depending on the operating mode. Figure 7 below shows the DSM250 keys and their names.



Figure 7 – Keypad and Key Names

In the normal viewing mode where your favorite screens are displayed, the keys on the DSM250 keypad have the following functions:

**Power Key** (🔌) – turns the DSM250 off (see section 3.1 on page 6 for details). A momentary press of this key can also be used to accept or cancel an Alert (see section 8.2.1 on page 160 for details).

**Lights Key** (☀️) – a quick press cycles the backlight brightness between three programmed brightness levels (see Section 5.2.4.3 on page 31 for details), while a long press cycles the DSM250 through 8 programmable color palettes (see Section 5.2.4.4 on Page 31).

**Up Key** (⬆️) – switches the display from the current favorite screen to the next highest numbered favorite screen that is enabled for that particular mode.

**Down Key** (⬇️) – switches the display from the current favorites screen to the next lowest numbered favorite screen that is enabled for that particular mode

**Enter Key** (⬅️) – changes from favorite screens mode to menu mode

In menu mode, a legend appears along the bottom of the screen displaying the function of each of the keys. The functions differ slightly depending on whether a menu is being accessed, a selection is being made from a list of possible data values, or a numeric value is being increased or decreased.

### 3.3.1 Navigating in a Menu

When accessing a menu, the keys on the DSM250 keypad have the following functions:

# DSM250 User's Manual

---

**Power Key** (⏻) – turns the DSM250 off (see Section 3.1 on page 6 for details).

**Back Key** (⊙) – returns to the next higher-level menu. If already at the top-level menu, exits menu mode returns to favorite screens mode. Menu levels are indicated with indentation of the text within the menus.

**Scroll Up Key** (↑) – changes the currently selected (or highlighted) menu item from the presently selected one to the one immediately above it. If the top menu item is already selected, the selection wraps to the bottom menu item.

**Scroll Down Key** (↓) – changes the currently selected (or highlighted) menu item from the presently selected one to the one immediately below it. If the bottom menu item is already selected, the selection wraps to the top menu item.

**Enter Key** (↵) – if the currently selected menu item has a submenu, opens that submenu. If the currently selected menu item has an editable value (indicated by a colon (:)) followed by the data value, moves the selection to the editable value and changes the keys to edit mode.

## 3.3.2 Choosing a Value from a List

When editing a value chosen from a list, the keys on the DSM250 keypad have the following functions:

**Power Key** (⏻) – turns the DSM250 off (see Section 3.1 on page 6 for details).

**Back Key** (⊙) – aborts the edit and restores the editable value to its previous value

**Scroll Up Key** (↑) – changes the currently selected editable value from the presently selected one to the one immediately above it in the list of possibilities. If the top menu item is already selected, the selection wraps to the bottom menu item.

**Scroll Down Key** (↓) – changes the currently selected editable value from the presently selected one to the one immediately below it in the list of possibilities. If the bottom menu item is already selected, the selection wraps to the top menu item.

**Enter Key** (↵) – Accepts the currently displayed value and stores it.

## 3.3.3 Entering a Numeric Value

When editing a numeric value, the keys on the DSM250 keypad have the following functions:

**Power Key** (⏻) – turns the DSM250 off (see Section 3.1 on page 6 for details).

**Cancel Key** (⊙) – aborts the edit and restores the editable value to its previous value

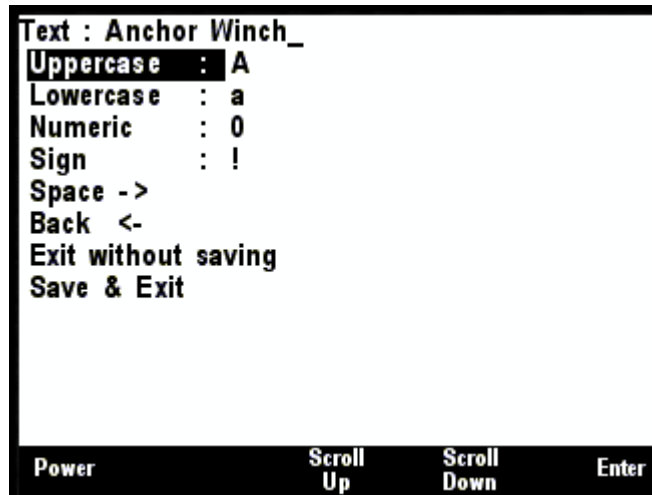
**Increase Key** (↑) – increases the editable value

**Decrease Key** (↓) – decreases the editable value

**Accept Key** (↵) – Accepts the currently displayed value and stores it.

## 3.3.4 Entering a Textual Value

When entering a text string, the following menu will be presented:



**Figure 8 – Entering a Textual Value**

The top line contains the textual string that has already been entered. New characters are appended one at a time to the end of the line, at the position marked by the underscore.

To append an uppercase character, use the **Scroll Up** and **Scroll Down** buttons to select **Uppercase** and then press **Enter** to go across to the characters. Now use the **Scroll Up** and **Scroll Down** buttons again to select the required character, and press **Enter** to transfer the character to the cursor position. If another uppercase character is required, repeat this last step, or press the **Back** button to return to the choices on the left.

To append a lowercase character, use the **Scroll Up** and **Scroll Down** buttons to select **Lowercase** and then press **Enter** to go across to the characters. Now use the **Scroll Up** and **Scroll Down** buttons again to select the required character, and press **Enter** to transfer the character to the cursor position. If another lowercase character is required, repeat this last step, or press the **Back** button to return to the choices on the left.

To append a numeral, use the **Scroll Up** and **Scroll Down** buttons to select **Numeric** and then press **Enter** to go across to the numbers. Now use the **Scroll Up** and **Scroll Down** buttons again to select the required numeral, and press **Enter** to transfer the numeral to the cursor position. If another numeral is required, repeat this last step, or press the **Back** button to return to the choices on the left.

To append a punctuation character or other symbol, use the **Scroll Up** and **Scroll Down** buttons to select **Sign** and then press **Enter** to go across to the sign characters. Now use the **Scroll Up** and **Scroll Down** buttons again to select the required character, and press **Enter** to transfer the character to the cursor position. If another sign character is required, repeat this last step, or press the **Back** button to return to the choices on the left.

To append a space, use the **Scroll Up** and **Scroll Down** buttons to select **Space** and then press **Enter**.

To delete the character immediately preceding the underscore, use the **Scroll Up** and **Scroll Down** buttons to select **Back** and then press **Enter**. Note that it is not possible to delete the entire text string; use the **Back** function repeatedly to delete the characters one at a time.

# DSM250 User's Manual

---

To abort the entire textual edit, and return to the original field without changing the contents of the field, use the **Scroll Up** and **Scroll Down** buttons to select **Exit without Saving** and then press **Enter**.

To enter the text string in the original field, use the **Scroll Up** and **Scroll Down** buttons to select **Save and Exit** and then press **Enter**.



## 4 Important Concepts

### 4.1 Favorite Screens

The DSM250 can display many different types of information in many different configurations. It is capable of displaying up to four distinct windows on its screen at one time. Rather than making you select from among the many types of available information any time you want to change the displayed data, the DSM250 has the concept of “Favorite Screens”. A “Favorite Screen” is a combination of display settings, data to display, and formats in which to display the data. The DSM250 supports up to 16 different favorite screens.

### 4.2 Categories and Data Types

The DSM250 is capable of displaying many types of information. In order to make it easier to locate a specific type of information to display, the different types of information are organized into general categories:

AC Bus	AC Generator	AC Utility
Anchor Watch	DC	Depth
Engine	Environment	Fuel Management
GPS	Heading	Navigation
Rudder	Speed	Indicator
Tank	Temperature	Time
Transmission	Vessel	Wind

The following sections explore each category in detail and spell out all of the data types that are available for display, if the appropriate sensors are installed in the network.

#### 4.2.1 AC Bus

**Average Frequency** – displays average frequency of the AC power on the bus

**Average L-N Voltage** – displays average line to neutral RMS voltage of the AC power on the bus

**Average L-L Voltage** – displays average line to line RMS voltage of the AC power on the bus

**Phase A Frequency** – displays frequency of the AC power on phase A of the Bus

**Phase A L-N Voltage** – displays phase A Line-to-Neutral RMS voltage of the AC Bus

**Phase A L-L Voltage** – displays phase A Line-to-phase B Line RMS voltage of the AC Bus

**Phase B Frequency** – displays frequency of the AC power on phase B of the bus

**Phase B L-N Voltage** – displays phase B Line-to-Neutral RMS voltage of the AC Bus

**Phase B L-L Voltage** – displays phase B Line-to-phase C Line RMS voltage of the AC Bus

**Phase C Frequency** – displays frequency of the AC power on phase C of the bus

**Phase C L-N Voltage** – displays phase C Line-to-Neutral RMS voltage of the AC Bus

**Phase C L-L Voltage** – displays phase C Line-to-phase A Line RMS voltage of the AC Bus

#### 4.2.2 AC Generator

**Average Current** – displays the average current of the AC power on the generator

**Average Frequency** - displays the average frequency of the AC power on the generator

# DSM250 User's Manual

---

- Average L-N Voltage** – displays average line to neutral RMS voltage of the AC power on the generator
- Average L-L Voltage** – displays average line to line RMS voltage of the AC power on the generator
- Total Real Power** – displays real power output by the generator
- Total Reactive Power** – displays reactive power output by the generator
- Total Apparent Power** – displays apparent power output by the generator
- Total Power Factor** – displays power factor of the generator
- Total kWh Export** – displays total energy produced by the generator
- Total kWh Import** – displays total energy consumed by the generator
- Phase A Frequency** – displays frequency of the AC power on phase A of the Generator
- Phase A L-N Voltage** – displays phase A Line-to-Neutral RMS voltage of the Generator
- Phase A L-L Voltage** – displays phase A Line-to-phase B Line RMS voltage of the Generator
- Phase B Frequency** - displays frequency of the AC power on phase B of the generator
- Phase B L-N Voltage** – displays phase B Line-to-Neutral RMS voltage of the Generator
- Phase B L-L Voltage** – displays phase B Line-to-phase C Line RMS voltage of the Generator
- Phase C Frequency** - displays frequency of the AC power on phase C of the generator
- Phase C L-N Voltage** – displays phase C Line-to-Neutral RMS voltage of the Generator
- Phase C L-L Voltage** – displays phase B Line-to-phase A Line RMS voltage of the Generator

## 4.2.3 AC Utility

- Average Current** – displays average current of the AC power on the utility
- Average Frequency** - displays average frequency of the AC power on the utility
- Average L-N Voltage** – displays average line to neutral RMS voltage of the AC power on the utility
- Average L-L Voltage** – displays average line to line RMS voltage of the AC power on the utility
- Total Real Power** – displays real power output by the utility
- Total Reactive Power** – displays reactive power output by the utility
- Total Apparent Power** – displays apparent power output by the utility
- Total Power Factor** – displays power factor of the utility
- Total kWh Export** – displays total energy produced by the utility
- Total kWh Import** – displays total energy consumed by the utility
- Phase A Frequency** – displays frequency of the AC power on phase A of the Utility
- Phase A L-N Voltage** – displays phase A Line-to-Neutral RMS voltage of the Utility
- Phase A L-L Voltage** – displays phase A Line-to-phase B Line RMS voltage of the Utility
- Phase B Frequency** - displays frequency of the AC power on phase B of the utility
- Phase B L-N Voltage** – displays phase B Line-to-Neutral RMS voltage of the Utility
- Phase B L-L Voltage** – displays phase B Line-to-phase C Line RMS voltage of the Utility
- Phase C Frequency** - displays frequency of the AC power on phase C of the utility
- Phase C L-N Voltage** – displays phase C Line-to-Neutral RMS voltage of the Utility
- Phase C L-L Voltage** – displays phase C Line-to-phase A Line RMS voltage of the Utility

## 4.2.4 Anchor Watch

The DSM250 provides a graphical display of the Anchor Alert (section 8.3.7.9) parameters. When the vessel is anchored, the position of vessel at the point of dropping the anchor is entered in to the Anchor Alert plus the maximum distance that the boat can drift from that position (normally a little more than the amount of Anchor Chain that you have let out). If the boat moves beyond that radius,

an Alert is triggered. The Anchor Watch display shows the last reported position of the vessel relative to the reported Anchor Drop position and the radius of the alert (see section 7.1 for more details on the display).

## 4.2.5 DC

The DSM250 supports the display of information for up to 64 DC sources including alternators, batteries, solar cells, wind generators, etc., with special parameters for batteries (i.e., State of Charge, Time Remaining, etc.).

**Current** – displays electrical current being sourced to/from the battery

**Voltage** – displays voltage measured at the battery

**Temperature** – displays battery case temperature

**State of Charge** – displays estimated state of charge of the battery (please consult the battery monitor's documentation for details)

**State of Health** - displays estimated state of health of the battery (please consult the battery monitor's documentation for details)

**Time Remaining** – displays estimated time remaining for the battery given its current temperature and rate of discharge (please consult the battery monitor's documentation for details)

**Ripple Voltage** – displays magnitude of the AC component riding on top of the DC voltage

**Power** – displays the power produced or consumed by the battery

## 4.2.6 Depth

**Transducer Offset** – when negative, it displays distance from the depth transducer to the bottom of the keel, when positive it displays distance between the depth transducer and the waterline

**Water Depth**– displays the current water depth including the transducer offset. If the transducer offset is programmed to a negative number, then the water depth represents the depth below the keel. If the transducer offset is positive, then the water depth represents water line depth.

**Water Below Transducer** – displays the distance from the depth transducer to the sea or lake bottom (the transducer offset is not taken into account)

## 4.2.7 Engine

The DSM250 supports the display of information for up to 64 engines.

**Boost Pressure** – displays the boost pressure of a supercharger or turbocharger

**Hours** – displays the number of hours of operation reported by the engine

**Exhaust Gas Temp.** – displays the temperature of the engine's exhaust gas

**Fuel Pressure** – displays the pressure of the fuel for the engine

**Fuel Rate** – displays the rate of fuel consumption for the engine

**Oil Pressure** – displays the engine's oil pressure

**Oil Temp** – displays the engine's oil temperature

**Tachometer** – displays the rotational speed of the engine

**Tilt/Trim** – displays the tilt or trim of the drive

**Voltage** – displays the electrical power supply voltage measured at the engine

**Water Pressure** – displays the engine's water pressure

**Water Temp** – displays the engine's water temperature

**Fuel Economy** – displays the current fuel economy for the engine

## 4.2.8 Environment

**Barometer** – displays the current atmospheric (barometric) pressure

# DSM250 User's Manual

---

- Heat Index** – displays the current heat index based on air temperature and humidity
- Humidity Inside** – displays the relative humidity from an indoor humidity sensor
- Humidity Outside** – displays the relative humidity for an outdoor humidity sensor
- Moon Phase** – displays the phase of the moon at the current time and position
- Sunrise** – displays the local time of sunrise for the current day and position
- Sunset** – displays the local time of sunset for the current day and position
- Dew Point** – displays the current dew point based on air temperature and humidity
- Temp Engine Room** – displays the air temperature from a sensor mounted in an engine room
- Temp Inside** – displays the air temperature from a sensor mounted inside the vessel
- Temp Main Cabin** – displays the air temperature from a sensor mounted inside the main cabin
- Temp Outside** – displays the air temperature from a sensor mounted outside
- Temp Sea** – displays the current temperature of the water
- Twilight AM** – displays the time of nautical twilight before sunrise for the current day and position
- Twilight PM** – displays the time of nautical twilight after sunset for the current day and position
- Weather** – displays a screen with a wide variety of weather-related data (See Section 7.8 for details)
- Wind Chill** – displays the current wind chill based on air temperature and wind speed

## 4.2.9 Fuel Management



**WARNING:** Maretron fuel management products are designed to be accurate and reliable; however they should be used only as aids for fuel management and not as a replacement for traditional fuel management techniques. **BEWARE:** Conditions can quickly change that drastically effect time and distance to empty.

You should not use the fuel management data types unless you fully understand all the parameters associated with fuel management. All fuel tanks and all engines must be included when setting up the DSM250 plus there must be accurate fuel rate sensors installed on the vessel and accurate speed information in order for the DSM250 to properly display fuel management information. You should also note that fuel levels may contain significant error if the boat is not sitting level in the water (i.e., sailboat heeled over or a power boat riding bow up won't necessarily report the correct amount of fuel). Even when setup correctly, the DSM250 should be used only as an aid and not the sole source for fuel management information.

**Total Fuel Economy** – displays distance traveled per unit fuel used (for example, miles per gallon or kilometers per liter) using the specified GPS and specified engine instances within the favorite screen setup (see Section 5.2.6.4.2 for details).

**Total Fuel Rate** – displays rate of fuel usage per unit time (for example, gallons or liters per hour) for all engine instances specified within the favorite screen setup (see Section 5.2.6.4.2 for details)

**Total Fuel Remaining** – displays total fuel remaining in all fuel tanks specified within the favorite screen setup (see Section 5.2.6.4.2. In order for the DSM250 to properly calculate total fuel remaining, tank monitors connected to the network must provide tank capacity in addition to fluid level.

**Distance to Empty** – displays the distance you can travel before all fuel is consumed, assuming all conditions remain the same. The DSM250 computes distance to empty using several different parameters including the total fuel remaining (see above) and fuel economy (also discussed above). Remember, conditions can rapidly change that may drastically effect distance to empty. For example, if you are going out to sea with the wind and current behind you, the distance to empty may indicate that there is enough fuel to return home when in fact there isn't enough fuel to return. Distance to empty is only applicable if the conditions remain the same.

**Time to Empty** – displays the amount of time you can travel before all fuel is consumed, assuming all conditions remain the same. The DSM250 computes time to empty using total fuel remaining (see above) and the engine(s) fuel rate. Remember, conditions can rapidly change that may drastically effect time to empty. For example, if you are going out to sea with the wind and current behind you, the time to empty may indicate that there is enough fuel to return home when in fact there isn't enough fuel to return. Time to empty is only applicable if the conditions remain the same.

**Total Fuel Capacity** – displays the total capacity of all fuel tanks. The DSM250 can only compute total fuel capacity assuming all totalized tanks are transmitting their capacity.

**Total Fuel Level** – displays the percentage of fuel remaining in all fuel tanks.

## 4.2.10 GPS

**Course Over Ground** – displays the current Course over Ground (either true or magnetic depending on the "Heading:" setting found under the "Units..." menu item)

# DSM250 User's Manual

---

**Lat/Lon** – displays the current latitude and longitude of the vessel

**Speed Over Ground** – displays the current speed over ground

**Status** – displays the current operating mode and status of the specified GPS receiver

## 4.2.11 Heading

**Magnetic/True** – displays the current heading of the vessel (the direction the vessel is pointing) relative to true or magnetic north depending on the unit setting of the heading parameter (see Section 5.2.7.1)

**Rate of Turn** – displays the angular rate of rotation of the vessel about the vertical axis

**Variation** – displays the magnetic variation used to convert between true and magnetic headings

## 4.2.12 Indicator

**Status** – displays the on/off status of an indicator

## 4.2.13 Navigation

The DSM250 is not a primary navigation device; that is, it does not provide means for entering and storing waypoint and route data. The DSM250 can receive information on the current leg of the voyage from a primary navigation device (such as a chart plotter or PC with navigation software and NMEA 2000<sup>®</sup> interface) and display this information.

**Bearing Origin to Destination** – displays the direction from the origin waypoint to the destination waypoint

**Bearing To Waypoint** – displays the bearing to the destination waypoint

**Course Over Ground** – displays the current Course over Ground (always referenced to true north)

**Cross Track Error** – displays the cross-track error (minimum distance from the boat to the programmed route)

**Distance To Waypoint** – displays the distance to the destination waypoint

**Est. Time of Arrival** – displays the Estimated Time of Arrival at the waypoint

**Lat/Lon** – displays the current latitude and longitude of the vessel

**Rolling Road** – displays navigation information for the current leg of the route

**Set/Drift** – displays the direction (set) and speed (drift) of the water current

**Speed Over Ground** – displays current Speed over Ground (relative to the earth, not the water)

**Time To Go** – displays the estimated Time to Go until arrival at the waypoint

**VMG to Waypoint** – displays the Velocity Made Good; that is, the speed at which the distance to the waypoint is decreasing

**Waypoint Number** – this displays the number of the destination waypoint

## 4.2.14 Rudder

The DSM250 supports the display of information for up to four rudders.

**Rudder Angle & Order** – displays the angle of the vessel's rudder as indicated by the rudder sensor, as well as the angle to which the rudder has been commanded by an autopilot or steering device

## 4.2.15 Special Devices

**Watermaker** - displays a screen with several different parameters associated with Sea Recovery watermakers

## 4.2.16 Speed

**Speed Through Water** – displays the speed of the boat relative to the water

**Speed Over Ground** - displays Speed over Ground (relative to the earth, not the water)

**Total Log** – displays the total distance traveled by the vessel since the log indicator was installed

**Trip Log** – displays the distance traveled by the vessel since the trip indication of the log indicator was last reset

## 4.2.17 Tank

The DSM250 supports the display of information for up to sixteen tanks types (16 fuel plus 16 water, etc.).

**Capacity** – displays the fluid capacity of the tank

**Level** – displays the level of fluid in the tank as a percentage of its capacity

**Remaining** – displays the amount of fluid in the tank

# DSM250 User's Manual

---

## 4.2.18 Temperature

The DSM supports the display of temperatures. Each temperature sender on the bus is required to state the source of the temperature, which may be one of:

- Bait Well
- Dew Point
- Engine Room
- Exhaust Gas
- Freezer
- Heat Index
- Heating System
- Inside
- Live Well
- Main Cabin
- Outside
- Refrigeration
- Sea
- Wind Chill
- User Defined 129 – User Defined 144

## 4.2.19 Time

**Local Date** – displays the current date referenced to the local time offset (see Section 5.2.7.12, on page 42 for details on how to set the local time offset)

**Date UTC** – displays the current date referenced to Universal Time Coordinated

**Moon Phase** – displays the phase of the moon at the current time and position

**Sunrise** – displays the local time of sunrise for the current day and position

**Sunset** – displays the local time of sunset for the current day and position

**Local Time** – displays the current time referenced to the local time offset (see Section 5.2.7.12, on page 42 for details on how to set the local time offset)

**Time UTC** – displays the current time referenced to Universal Time Coordinated (also known as Greenwich Mean Time, or GMT)

**Twilight AM** – displays the time of nautical twilight (i.e., the time of day when the sun is 12 degrees below the horizon in the morning) for the current day and position

**Twilight PM** – displays the time of nautical twilight (i.e., the time of day when the sun is 12 degrees below the horizon in the evening) for the current day and position

## 4.2.20 Transmission

The DSM250 supports the display of information for up to four transmissions.

**Gear** – displays the current gear of the transmission (forward, neutral, or reverse)

**Oil Pressure** – displays the pressure of the oil in the transmission

**Oil Temp.** – displays the temperature of the oil in the transmission

## 4.2.21 Vessel

**Keel** – displays the height of a swing keel

**Pitch** – displays the pitch of the vessel (rotation about the horizontal axis perpendicular to the ship's keel)

**Roll** – displays the roll of the vessel (rotation about the horizontal axis parallel to the ship's keel)



**Trim Tabs** – displays the position of the vessel’s trim tabs

## 4.2.22 Wind

**Dir. Apparent** – displays the angle of the wind relative to the vessel center line as it appears to an observer on the deck of a moving or stationary vessel (does not subtract out the speed of the vessel)

**Dir. Ground Ref.** – displays the angle of the wind relative to true or magnetic north (depending on the unit setting of the “heading” parameter, see Section 5.2.7.1) measured relative to a stationary observer, calculated using heading, course over ground (COG), and speed over ground (SOG)

**Dir. True Vessel Ref** – displays the angle of the wind relative to the vessel center line (vessel’s speed is subtracted from Apparent wind direction), calculated using speed through water (STW) or speed over ground (SOG) (depending on the unit setting of the “Wind True Vessel Ref.” Parameter, see Section 5.2.7.6)

**Speed Apparent** – displays the speed of the wind as it appears to an observer on the deck of a moving or stationary vessel (does not subtract out the speed of the vessel)

**Speed Ground Ref.** – displays the speed of the wind relative to a stationary observer, calculated using heading, course over ground (COG), and speed over ground (SOG)

**Speed True Vessel Ref** – displays the speed of the wind as it would appear to an observer if the vessel was stopped in the water, calculated using speed through water (STW) or speed over ground (SOG) (depending on the unit setting of the “Wind True Vessel Ref.” Parameter, see Section 5.2.7.6)

## 4.3 Alerts

An *alert* is a signal to a user that there is either an alarm or warning condition requiring user intervention.

Alerts are integrated in an NMEA2000® system. For each Alert, one device acts as a master, or Alert Source, and monitors a parameter against a preset threshold. When the parameter crosses this threshold, the Alert is displayed on the Alert Source and an Alert Message is sent out on the NMEA2000® bus to other devices capable of displaying Alerts. Optionally, an Annunciator message is sent to devices capable of sounding an audio alarm (e.g. the ALM100). Currently, the DSM250 and the N2KView™ Vessel Monitoring Software are capable of generating and receiving Alert Messages. The Alert may be accepted or cancelled from any capable device, in which case an Alert Response Message is sent to the Alert Source, which in turn will turn the Annunciators off and inform the devices on the bus of the new Alert Status.

### 4.3.1 Alert Types

There are two classes of alerts, which are distinguished by their severity:

- *Alarm* – An alarm is a type of alert announcing a condition requiring immediate attention or user intervention. Alarms are shown in red (when Active), and always appear above the warnings on the Alert Status Screen.
- *Warning* – A warning is a type of alert announcing a condition requiring non-immediate attention for precautionary reasons. Warnings are shown in yellow (when Active), and always appear below alarms on the Alert Status Screen.

### 4.3.2 Alert Terminology

The following alert terminology, consistent with International Maritime Organization Code on Alarms and Indicators, is used in N2KView™ and the DSM250.

- *Accept* – The user action of acknowledging the existence of an alert. Alerts are only accepted when they are Active
- *Cancel* – The user action of removing an alert from the list of displayed alerts. Alerts may only be cancelled if the condition causing the alert has been removed.
- *Clear* – An alert is cleared when the condition causing the alert is removed. This is not a user action.
- *Trigger* – An alert is triggered when the condition monitored by the alert is met.

### 4.3.3 Alert Priority

Each alert has a priority which you can define, ranging from 0 to 4000 with 0 the highest or most important priority and 4000 the lowest or least important priority. Alarms always have a higher priority than Warnings (i.e. an Alarm with a priority of 4000 has a higher priority than a warning with priority 0).

### 4.3.4 Vessel Alert Operating Modes

You can configure alerts to operate in one or more fixed operating modes, 1) disabled, 2) moored, 3) underway, or 4) anchored. This allows you to easily enable or disable groups of individual alarms depending on the vessel's operating mode. Setting the vessel alert operating mode is described in section 8.6.

The Operating Mode is one of:

- *Disabled* – All alerts are disabled. This mode should be used when the vessel is in storage, dry-dock, or otherwise out of operation.
- *Moored* - This mode is used when the vessel is secured to a structure that is permanently attached to the ground like a pier, wharf, dock, or mooring buoy.
- *Underway* - This mode is used when the vessel is not moored nor anchored.
- *Anchored* - This mode is used when the vessel is secured to the sea floor with an anchor.

# DSM250 User's Manual

---

## 4.3.5 Alert States

Alerts exist in one of five states.

- *Disabled* - A Disabled Alert is an alarm or warning that has yet to be enabled or activated. In this state, no action will be taken regardless of the value of the monitored parameter. A Disabled Alert May be enabled in which case it transitions to the Inactive state
- *Inactive* - An Inactive alert is an alarm or warning that has been enabled, but the condition causing the alert is not present. If the alert condition becomes true, the alert will become an *Active Alert*. An Inactive alert may be disabled, which causes it to transition to the *Disabled* state. New alerts are created in the Inactive State.
- *Active* - An Active alert is an alarm or warning where the condition to trigger the alert has been met, and is still present and the operator has not accepted the alert. An active alert is indicated by a flashing indicator on the Alert Status Screen, and by a flashing colored box at the top right of the DSM250 screen. This box will be visible on all screens. Also, annunciators that are programmed to sound when this alert is active will be sounding during this state. An active alert can be accepted by the user (causing it to become an *Accepted Alert*) or disabled by the user (causing it to become a *Disabled Alert*). If the condition causing the alert is rectified, the alert transitions to the Awaiting Cancel state.
- *Accepted* - An Accepted alert is an alarm or warning which was Active and has been accepted by the user. A solid indicator on the Alert Status Screen indicates an Accepted alert; annunciators are silenced. Normally, an alert is a serious matter that requires immediate attention and requires a deliberate attempt to remove the condition that caused the alert. Sometimes it isn't practical to immediately remove the condition that caused the alert; accepting the alert will silence the annunciators while the appropriate user action is being taken.
  - To prevent an alert that has accepted by the user from being forgotten, an accepted alert will transition back to being Active after a period of time set by the user. If the condition causing the alert is rectified (cleared), the alert will transition to the Inactive state.
  - You may disable the alert at this time, causing it to become a Disabled Alert.
- *Awaiting Cancel* - An Alert in the Awaiting Cancel state is an alert where the condition that caused the alarm or warning has been removed without the alert being accepted while it was Active. To avoid such alerts from being missed by the user, the alert is required to be cancelled. You may cancel the alert at this time, causing it to become an *Inactive Alert*, or you may disable the alert, causing it to become a *Disabled Alert*. Should the condition trigger the alert again, the alert will transition back to the Active state, incrementing a counter which is displayed on the Alert Status Screen in the "What Happened" column.

## 4.3.6 Available Alert Classes

The DSM250 has several classes of alerts, depending on the parameter for which an alert is being configured.

- *Low Alert* – The alert will become active if the monitored value drops below the value in this alert for longer than the time specified in the Set Delay field.
- *High Alert* – The alert will become active if the monitored value rises above the value specified in this alert for longer than the time specified in the Set Delay field.
- *Data Unavailable Alert* – The alert will become active if the monitored value is not received, or is received but with a value of "Data Not Available", for longer than the time specified in the Set Delay field.
- *On Alert* – The alert will become active if the monitored switch or flag becomes "ON" for longer than the time specified in the Set Delay field.

- *Off Alert* – The alert will become active if the monitored switch or flag becomes “OFF” for longer than the time specified in the Set Delay field.
- *Tripped Alert* – The alert will become active if the monitored circuit breaker becomes “Tripped” for longer than the time specified in the Set Delay field.
- *Course Alert* – The alert will become active if the monitored course differs from the Reference Direction by more than the Offset COG Set Point for longer than the time specified in the Set Delay field.
- *GPS Quality Alert* – The alert will become active if the GPS Quality drops below the level set in the GPS Quality Alert Set field for longer than the time specified in the Set Delay field.
- *Outside Radius Alert* – The alert will become active if the distance between the current GPS position and the Reference Latitude and Longitude rises above the value in the Outside Radius Alert Set field for longer than the time specified in the Set Delay field.
- *Inside Radius Alert* - The alert will become active if the distance between the current GPS position and the Reference Latitude and Longitude falls below the value in the Outside Radius Alert Set field for longer than the time specified in the Set Delay field.
- *Anchor Alert* – Similar to the Outside Radius Alert, this alert will become active if the distance between the current GPS position and the Reference Latitude and Longitude rises above the value in the Outside Radius Alert Set field for longer than the time specified in the Set Delay field. The Anchor Alert is more suited for smaller radii, and can be displayed graphically in the Anchor Watch Display.
- *Direction Alert* – The alert will become active if the monitored course differs from the Reference Direction by more than the Offset Wind Direction Set Point for longer than the time specified in the Set Delay field.
- *Timer Alert* – The alert will become active when the time reaches the time specified in the Alarm Time field, and thereafter after the intervals specified in the Repeat Interval field.

# DSM250 User's Manual

---

## 5 Operating Modes

The DSM250 has two main operating modes including normal viewing of information in the favorite screens mode (Section 5.1) and the menu mode (Section 5.2).

### 5.1 Favorite screens modes

After the power up screen (see Section 3.1), the DSM250 always enters the favorite screens mode. In the favorite screens modes, the DSM250 displays one of up to sixteen “favorite” screens. Each “favorite” screen can display one, two, three, or four information displays. Each information display can show any displayable data in any display type supported by that data. In favorite screens mode, the DSM250 can operate in one of two ways:

- Manual* mode - a particular “favorite” screen remains on the display until you selects another one, or
- Auto* mode - the DSM250 automatically cycles between “favorite” screens, at time intervals which are individually programmable for each “favorite” screen.

An example screen of the DSM250 running in favorite screens mode can be seen in Figure 9 below.

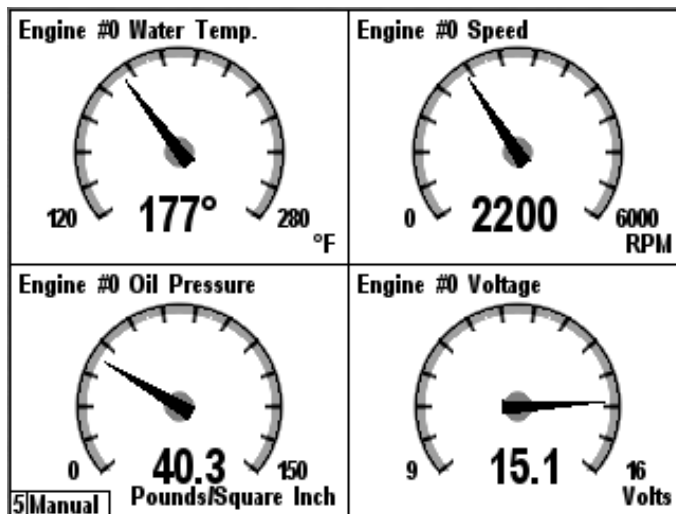


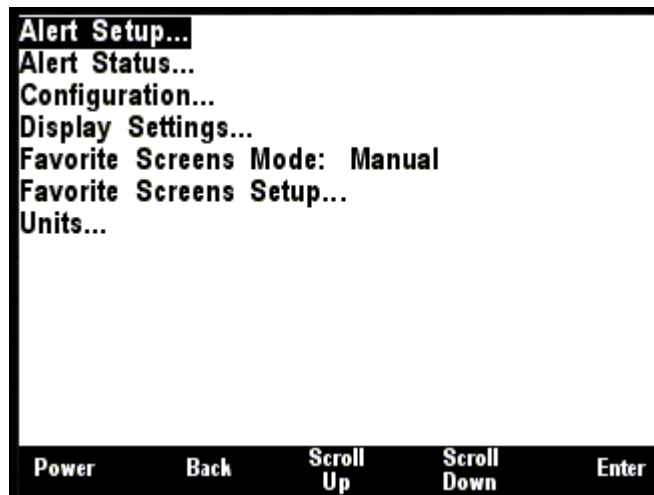
Figure 9 – DSM250 Running in Favorite Screens Mode

The very bottom left hand corner of the screen shows two important parameters: 1) it indicates which favorite screen is being displayed (in this case Favorite #5), and 2) it indicates that the DSM250 is currently operating in the *Manual* mode. *Auto* would appear in place of *Manual* if the DSM250 was operating in *Auto* mode.

### 5.2 Menu Mode

The menu mode is entered while viewing favorite screens by pressing the **Enter** key (↵).

In menu mode, the DSM250 may be configured by scrolling up and down the menu and selecting one of the submenus found there. The DSM250 Main Menu can be seen in Figure 10 below.



**Figure 10 – Main Menu**

The menu has the following structure

- Alert Setup...(5.2.1)
  - Add New Alert...(8.2)
  - Delete Alert...(8.4)
  - Edit Alert...(8.5)
  - Operating Mode (8.6)
  - Advanced Configuration... (8.7)
  - Restore Factory Defaults (8.8)
- Alert Status... (5.2.2)
- Configuration...
  - Device Configuration... (5.2.3.1)
  - Device Selection... (5.2.3.2)
- Display Settings...
  - Advanced Configuration... (5.2.4.1)
  - Advanced Information... (5.2.4.2)
  - Backlight... (5.2.4.3)
  - Color Setup... (5.2.4.4)
  - Demo Mode (5.2.4.5)
  - Keypad Beep (5.2.4.6)
  - Label (5.2.4.7)
  - Language (5.2.4.8)
  - Software Version (5.2.4.9)
- Favorite Screens Mode (5.2.4.7)
- Favorite Screens Setup... (5.2.6)
- Units... (5.2.6.4.2)

# DSM250 User's Manual

---

## 5.2.1 Alert Setup Menu

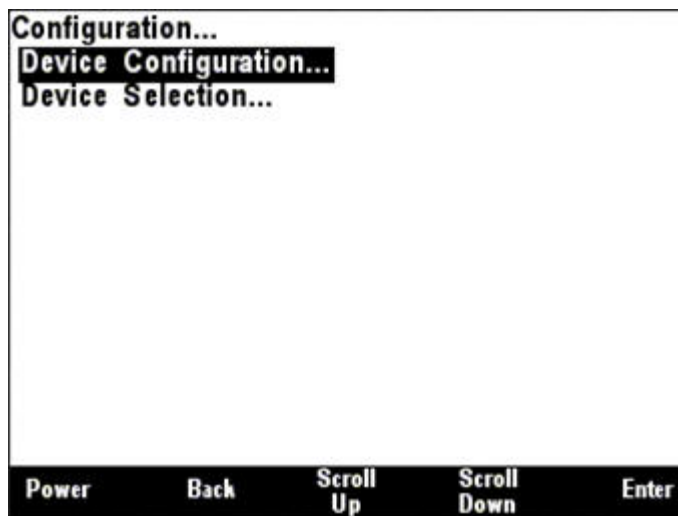
Selecting **Alert Setup...** from the Main Menu allows you to create, delete, and edit the Alerts stored in the DSM250, and to change the operating mode of the vessel. See section 8 for details on the Alerts.

## 5.2.2 Alert Status

Selecting **Alert Status...** from the Main Menu will display a list of currently active Alerts in the DSM250. See section 8.1.1 for details on the Alert Status Screen.

## 5.2.3 Configuration Menu

The configuration menu allows you to change the configuration of certain types of Maretron NMEA 2000® devices, as well as to select from which NMEA 2000® nodes data may be received. The available options within the Configuration screen are shown in Figure 11.



*Figure 11 – Configuration Screen*

### 5.2.3.1 Device Configuration

The ability to calibrate and configure other devices on the bus is a major portion of this manual. For this reason it has been given an entire section. See section 6 for details.

### 5.2.3.2 Device Selection

The “**Device Selection...**” menu allows you to enable and disable the display of data from individual NMEA 2000® devices. In this manner, multiple devices of the same type may be used in redundant and fail-safe configurations. A typical “**Device Selection...**” menu for a network configuration can be seen in Figure 12 below.

**NOTE:** Now that you can select instances for each displayed parameter, you do not need to configure this menu. This menu entry is retained for backward compatibility.



Configuration...  
Device Selection...

NA	Manufacturer	Model	SN#	Status	Display
-	Maretron	RAA 100	2097151	Offline	On
21	Maretron	GPS 100	1140001	Online	On
62	Maretron	SSC200	1120002	Online	On
03	Maretron	DST 100	1180003	Online	On
54	Maretron	USB 100	1160004	Online	On
15	Maretron	DSM200	1100005	Online	On
A8	Maretron	J2K 100	1240008	Online	On
86	Maretron	WSO 100	1200006	Online	On
97	Maretron	EMS 100	1220007	Online	On
B9	Maretron	TLA 100	1260009	Online	On

Power      Back      Scroll Up      Scroll Down      Enter

*Figure 12 – Device Selection Screen*

The “**NA**” column of the menu displays the node address the device is using.

The “**Manufacturer**” column of the menu displays the manufacturer of the device.

The “**Model**” column displays the model number of the device.

The “**SN#**” column displays the serial number of the device, so that any of two or more devices of the same manufacturer and model number may be distinguished from one another.

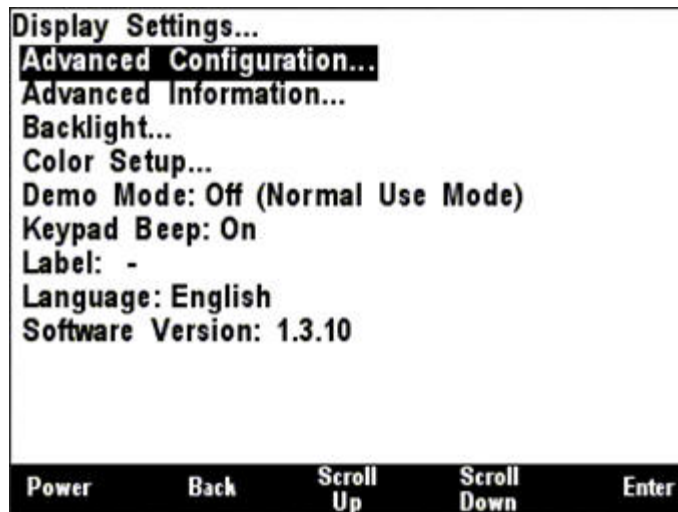
The “**Status**” column indicates whether the device is currently connected to the bus and is responding to queries (“Online”), or has been disconnected from the bus, has lost power, or for some other reason is not responding to queries (“Offline”).

The “**Display**” column indicates whether data from that particular device is accepted for display by the DSM250 (“On”) or that the DSM250 ignores data transmitted by this device (“Off”). By scrolling to the device and pressing the Enter key (↵), you may then use the Scroll Up (↑) and Scroll Down (↓) keys to toggle the “Display” status for this particular device. Once you are satisfied with the state of the “Display” setting, press the Enter key (↵) to accept the setting.

The DSM250 will retain information on devices that have been removed from the bus or powered down (“Offline”) so that when they are placed back on the bus, they will assume their prior “Display” setting.

## 5.2.4 Display Settings Menu

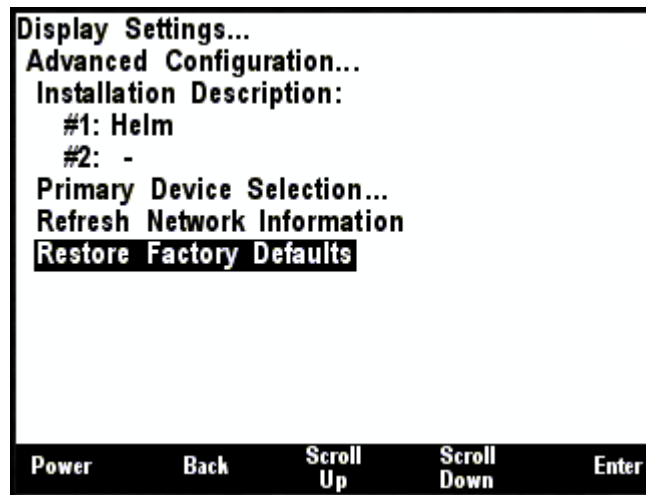
The display settings menu allows you to change parameters related to display operation.



*Figure 13 – DSM250 Display Settings Screen*

## 5.2.4.1 Advanced Configuration

Advanced Configuration changes some complex parameters within the device, and should only be performed by an advanced user. Typically advanced configuration is only done at installation and should not need to be done while at sea.



*Figure 14 – DSM250 Advanced Configuration*

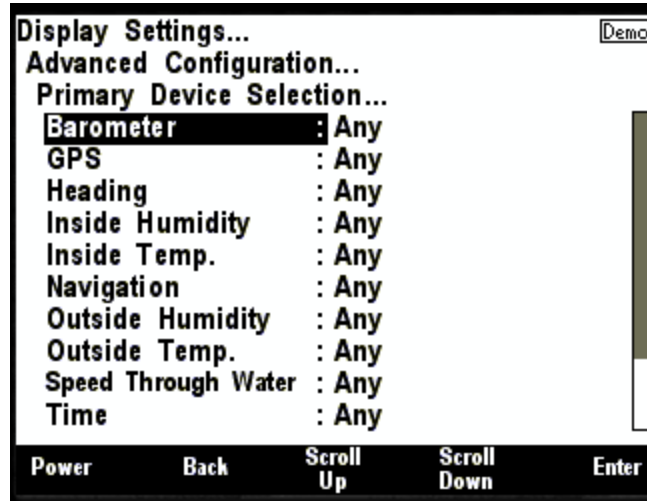
### 5.2.4.1.1 Installation Description

This entry allows you to modify the NMEA 2000 installation description text strings. You can enter any information you like here, such as the date the unit was installed, or the location in which it was installed, for later reference. Tools such as Maretron N2KAnalyzer allow you to view these values later. See section 3.3.4 for details on how to enter a textual value.

### 5.2.4.1.2 Primary Device Selection

Not all the data displayed by the DSM250 can be taken directly off the NMEA 2000 bus. Some require calculations with other parameters before the desired value can be displayed. An example

would be the display of ground relative wind. In this case, the wind measured by the weather station needs to be combined with the vessel heading, course over ground, and speed over ground. The instance number of the weather station is specified for each control. This table provides the instance numbers of the other parameters used in the calculations.



*Figure 15 – DSM250 Primary Device Selection*

#### 5.2.4.1.3 Refresh Network Information

The Device Configuration (5.2.3.1) and Device Selection (5.2.3.2) menus display a list of devices that have been detected on the NMEA2000 bus. This list is kept in memory permanently to reduce the overhead of requesting device information each time one of these pages is requested. Pressing the Enter key while this selection is highlighted will clear the list of devices. It will be necessary to perform this action to remove traces of devices that have been removed from the bus.

#### 5.2.4.1.4 Restore Factory Defaults

This option restores all settings on the DSM100 device to their factory default state.

#### 5.2.4.2 Advanced Information

The Advanced Information Page displays information pertaining to the permanent setup and configuration of the DSM250.

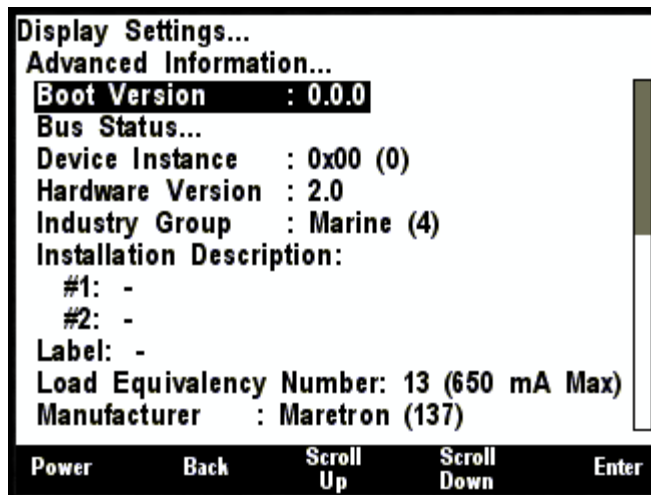


Figure 16 – DSM250 Advanced Information Screen

Most of the items within the Advanced Information... menu are obvious and not described here, although a less obvious menu item (Bus Status...) is described below.

#### 5.2.4.2.1 Bus Status

The DSM250 is capable of monitoring the NMEA 2000® network and displaying certain statistics.

**Baud Rate:** the speed capability of the connected network given in bits per second (bps),

**Voltage:** the network voltage as measured by the DSM250 in Volts,

**Traffic:** the percent usage of the total available bandwidth measured by the DSM250,

**Receive Rate:** the DSM250 measured received rate in frames per second (fps),

**Transmit Rate:** the DSM250 measured transmit rate in frames per second (fps),

**Error Count:** the DSM250 measured error frames since entering the Bus Status screen,

**Receive Counter:** the number of DSM250 measured received frames, and

**Transmit Counter:** the number of DSM250 measured transmitted frames.

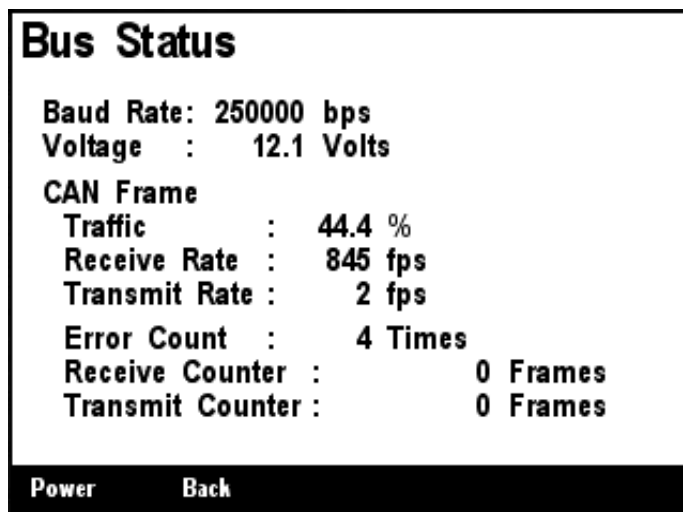
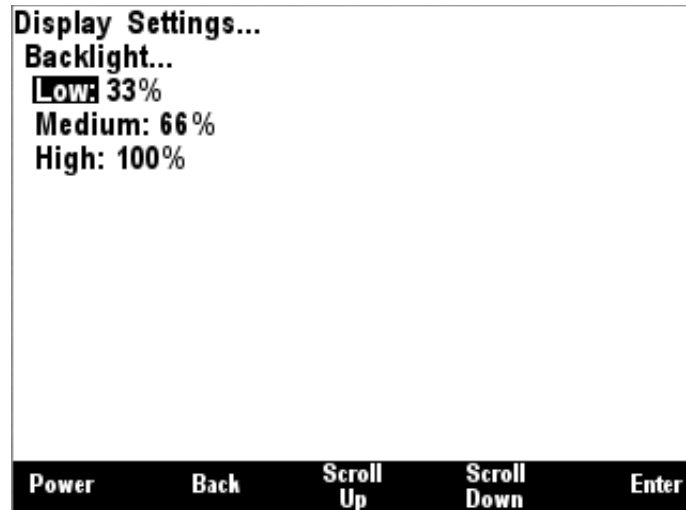


Figure 17 – Bus Status Display

### 5.2.4.3 Backlight

The DSM250 has three user-programmable lighting levels which may be cycled through using the Lights key (☀) on the keypad while the DSM250 is operating in favorite screens mode. Each time you quick press the Lights key (☀) in favorite screens mode, the DSM250 backlight will transition between the “Low” setting, the “Medium” setting, and the “High” setting. Note that a quick press of the Lights key (☀) changes the screen intensity or backlight while a long press changes the color palette as described in Section 5.2.4.4. The Backlight menu allows you to program the “Low”, “Medium”, and “High” brightness levels. The value that appears next to the appropriate setting is measured in percent of full brightness. The Backlight menu can be seen in Figure 18 below.



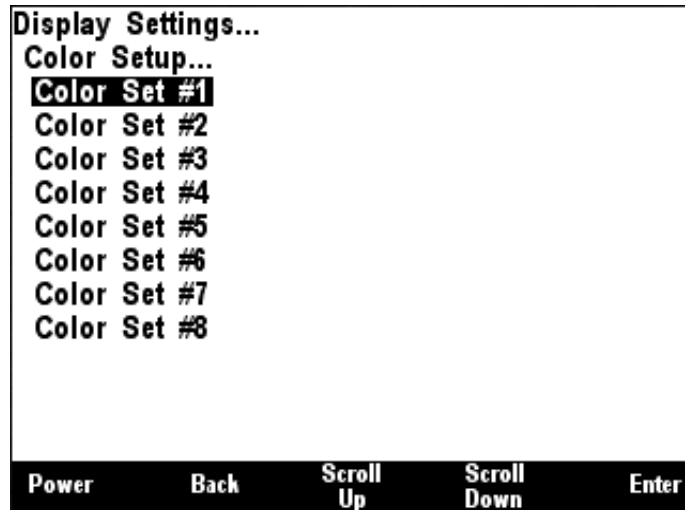
**Figure 18 – Backlight Menu**

### 5.2.4.4 Color Setup

The DSM250 has eight user-programmable color palettes. The default color palettes are as follows:

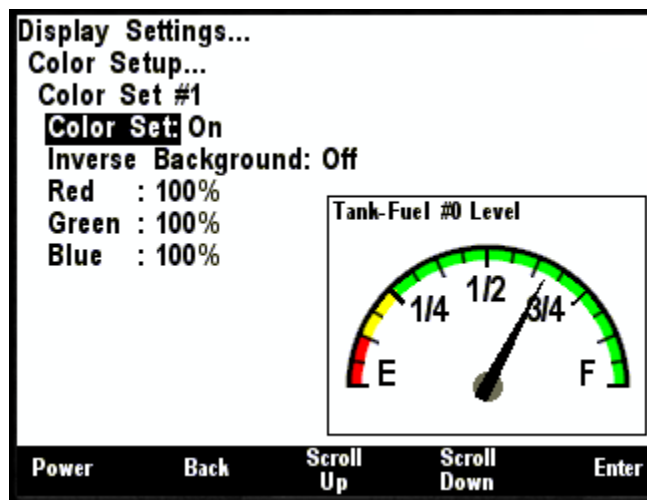
- Color Set #1 – White Back Ground, Black Foreground
- Color Set #2 – Red Back Ground, Black Foreground
- Color Set #3 – Blue Back Ground, Black Foreground
- Color Set #4 – Green Back Ground, Black Foreground
- Color Set #5 – Black Background, White Foreground
- Color Set #6 – Black Background, Red Foreground
- Color Set #7 – Black Background, Blue Foreground
- Color Set #8 – Black Background, Green Foreground

Choosing the “Color Setup...” menu item from the main “Display Settings..” menu takes you to the screen shown in Figure 19.



**Figure 19 – Color Palette Selection Screen**

Use the Scroll Up (⬆) or Scroll Down (⬇) keys to move the highlight to the color set that you want to change, and then press the Enter key (⬅). Selecting “Color Set #1” takes you to the screen shown in Figure 20.



**Figure 20 – Color Palette Configuration Screen**

You can enable or disable Color Set #1 by changing the “Color Set:” to “Off”. This will disable Color Set #1 while changing between color palettes when using a long press of the Lights key (⊙) when the DSM250 is operating in favorite screens mode. Change the “Color Set:” back to “On” to enable this color palette.

Notice that Color Set #1 has a white background (100% Red, 100% Green, and 100% Blue equals white) and that the foreground color is black. You can adjust the three different colors to achieve different color backgrounds. Use the Scroll Up (⬆) or Scroll Down (⬇) keys to move the highlight to the color you want to change, and then press the Enter key (⬅). Use the Scroll Up (⬆) or Scroll Down (⬇) keys with the percentage number selected to change that particular color’s intensity. You can also switch the background color to the foreground color by changing the Inverse Background to

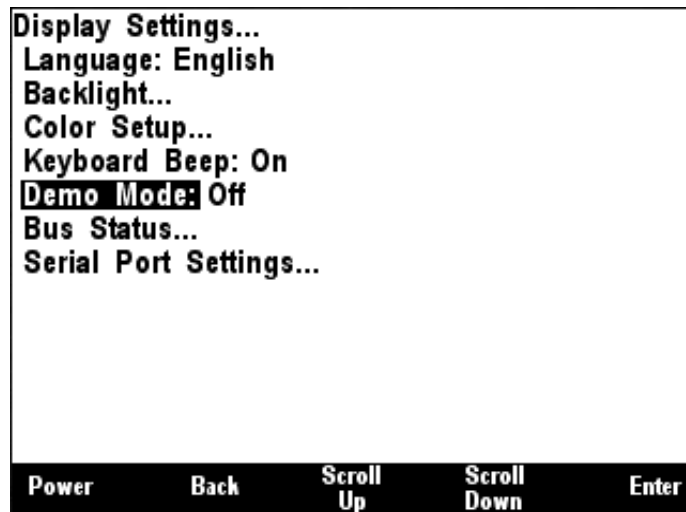
“On”. The background will switch to black and the percentage color settings are now used to define the foreground color.

### 5.2.4.5 Demo Mode

The DSM250 has a demo mode suited for displaying the capabilities of the unit. It causes the DSM250 to operate in a “simulated data” mode, where the DSM250 will install a set of pre-defined favorite screens and other configuration and will then display only the internally generated simulated data and will ignore any data arriving over the NMEA 2000® bus. While in demo mode, the DSM250 will display a “Demo” indicator in the upper right hand corner of the screen. Programming this option to “On (Show Room Mode)” or “On (Boat Show Mode, No Auto Reset)” will cause the DSM250 to enter the demo mode while programming this option for “Off (Normal Use Mode)” will cause the DSM250 to return to using data from the NMEA 2000® bus.

In order to be able to demonstrate all of the DSM250’s capabilities, the unit allows the user to setup and configure different screens while in demo mode. However, in a show room environment and five minutes after the last button push (i.e., the customer has walked away the demo unit), the DSM250 will reset itself to the default screens. There are others times where it is important that the DSM250 doesn’t automatically reset after five minutes to the default screens, for example at a boat show where it is desired to show specific screens while running in the demo mode and thus the “Boat Show Mode”.

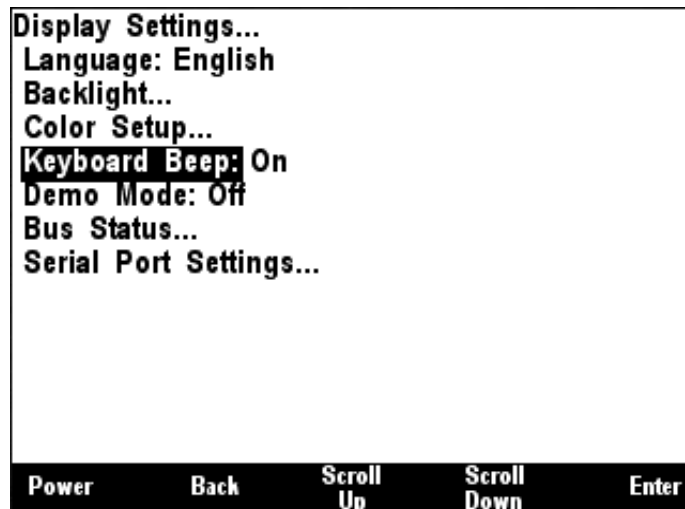
**WARNING:** All data displayed in demo mode is simulated. Do not use this data for vessel monitoring or navigation purposes.



**Figure 21 – Setting the Demo Mode**

### 5.2.4.6 Keyboard Beep

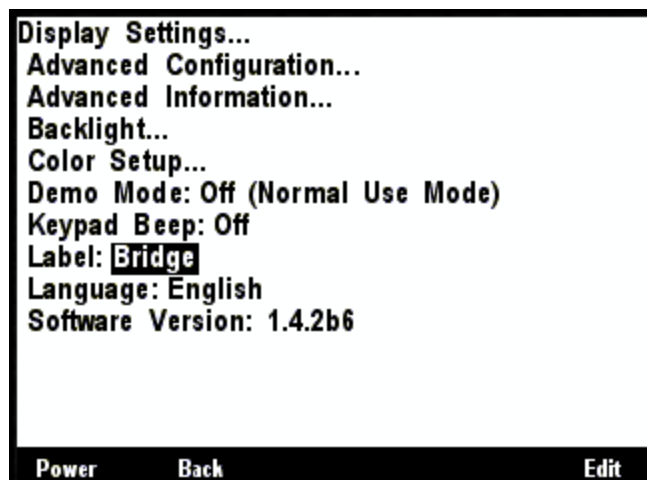
The DSM250 has an annunciator that can be programmed to beep every time a key is pressed. Conversely, the keypad beep may be disabled if desired.



**Figure 22 – Setting the Keyboard Beep Option**

## 5.2.4.7 Label

Each DSM250 can be given a software label. Normally this label will indicate the position of the DSM250 and is used by the Alert System to identify one DSM250 from another.



**Figure 23 – Editing the DSM250 Label**

## 5.2.4.8 Language

The DSM250 currently supports two languages: English and Dutch (Nederlands). Support for other languages is planned for future firmware releases. To change the currently used language, use the Scroll Up (↑) or Scroll Down (↓) keys to move the highlight to the “Language:” menu item, and then press the Enter key (↵) to move the highlight to the language selection on the right. Use the Scroll Up (↑) or Scroll Down (↓) keys to change the selection to the desired value, and then press the Enter key (↵) to confirm your selection. The DSM250 will then reset itself, after which the selected language will be used for menus and titles.

## 5.2.4.9 Software Version

This field displays the version of the Firmware running in the DSM250.



## 5.2.5 Favorite Screens Mode

The DSM250 supports two methods of operation in favorites mode: “Auto”, in which the DSM250 automatically cycles through all favorite screens that have been enabled for Auto mode, and “Manual”, in which the DSM250 continues to display the currently displayed favorite screen until you press the Scroll Up (↑) or Scroll Down (↓) keys, in which the DSM250 will display the next higher or lower numbered favorite screen, respectively, that is enabled for Manual mode.

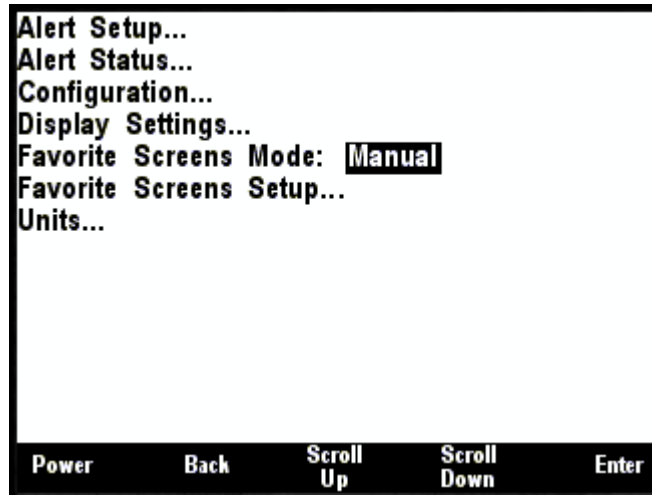


Figure 24 – Setting the Favorite Screens Mode

## 5.2.6 Favorite Screens Setup Menu

The DSM250 supports the configuration of sixteen favorite screens. The favorite setup screen allows you to select which of the twelve favorite screens you wish to configure.

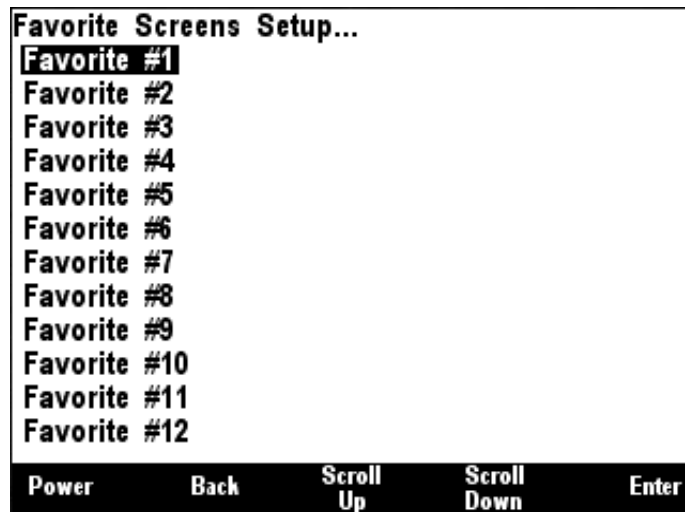
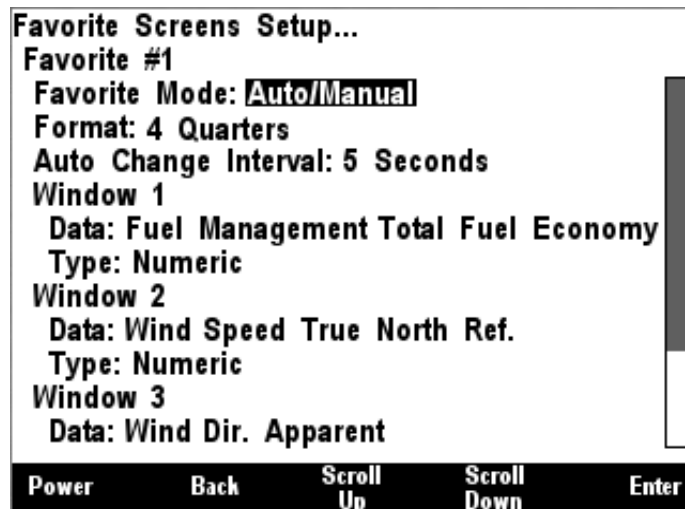


Figure 25 – Favorite Screens Setup Screen

Once you have selected a favorite screen to configure, you will see the screen shown in Figure 26 . The exact format of the setup screen will depend on the Format chosen.



*Figure 26 –Favorite Screen Parameters*

### 5.2.6.1 Favorite Mode

This entry allows you to select in which display method of favorite screens mode this particular favorite screen is enabled. This parameter has four possible settings:

- Off** – this favorite screen is disabled and is not displayed
- Auto** – this favorite screen is displayed only in Auto mode
- Manual** – this favorite screen is displayed only in Manual mode
- Auto/Manual** – this favorite screen is displayed in both Auto and Manual modes

### 5.2.6.2 Format

The DSM250 offers many methods and formats of displaying multiple data items at a given time. This parameter is used to program how many data items will appear on this particular favorite screen and in what sizes these items will appear. This parameter has the following settings:

- **Full Window** – one parameter will be displayed, taking up the entire screen
- **2/3 Top – 1/3 Bottom** – two parameters will be displayed, the first occupying the top 2/3 of the screen and the second occupying the bottom 1/3 of the screen
- **1/3 Top – 2/3 Bottom** – two parameters will be displayed, the first occupying the top 1/3 of the screen and the second occupying the bottom 2/3 of the screen
- **Half Left – Qtr – Qtr** – three parameters will be displayed, the first occupying the left half of the screen, the second occupying the upper right hand corner of the screen and the third occupying the lower right hand corner of the screen
- **Qtr – Half – Qtr** – three parameters will be displayed, the first occupying the top left hand corner of the screen, the second occupying the upper right hand corner of the screen, and the third occupying the lower right hand corner of the screen
- **Half Left/Right** – two parameters will be displayed, the first occupying the left half of the screen, and the second occupying the right half of the screen
- **Half Top/Bottom** – two parameters will be displayed, the first occupying the top half of the screen and the second occupying the bottom half of the screen

- **2 Qtrs – Half Bottom** – three parameters will be displayed, the first occupying the upper left hand corner of the screen, the second occupying the upper right hand corner of the screen, and the third occupying the bottom half of the screen
- **Half Top – 2 Qtrs** – three parameters will be displayed, the first occupying the top of the screen, the second occupying the lower left hand corner of the screen, and the third occupying the lower right hand corner of the screen
- **Four Quarters** – four parameters will be displayed, the first occupying the upper left hand corner of the screen, the second occupying the upper right hand corner of the screen, the third occupying the lower left hand corner of the screen, and the fourth occupying the lower right hand corner of the screen

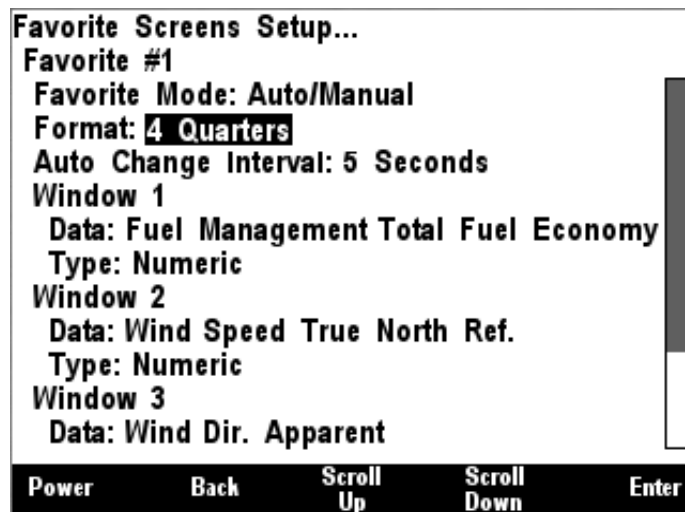


Figure 27 – Setting the Favorite Screen Format

### 5.2.6.3 Auto Change Interval

In Auto mode, this parameter determines the amount of time this favorite screen is displayed before the DSM250 automatically cycles to the next higher numbered favorite screen in the auto mode. This parameter is programmable to anywhere between 1 second and 180 seconds.

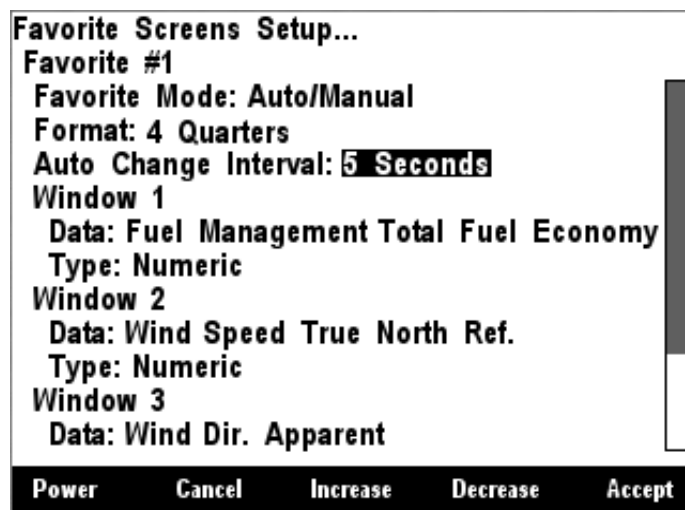


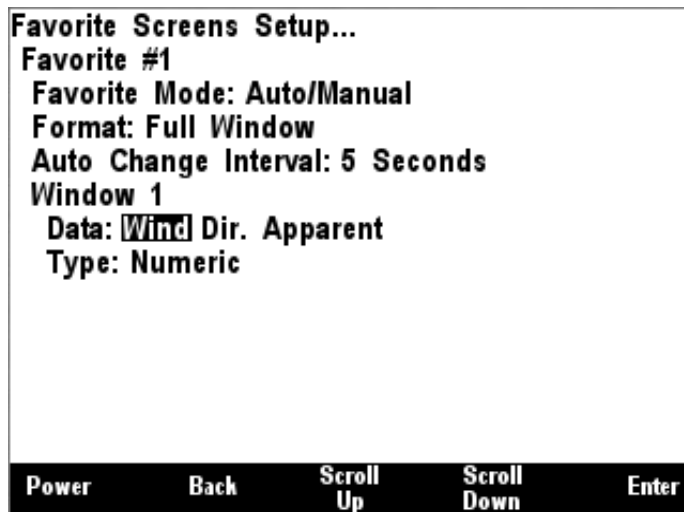
Figure 28 – Setting the Auto Change Interval

# DSM250 User's Manual

---

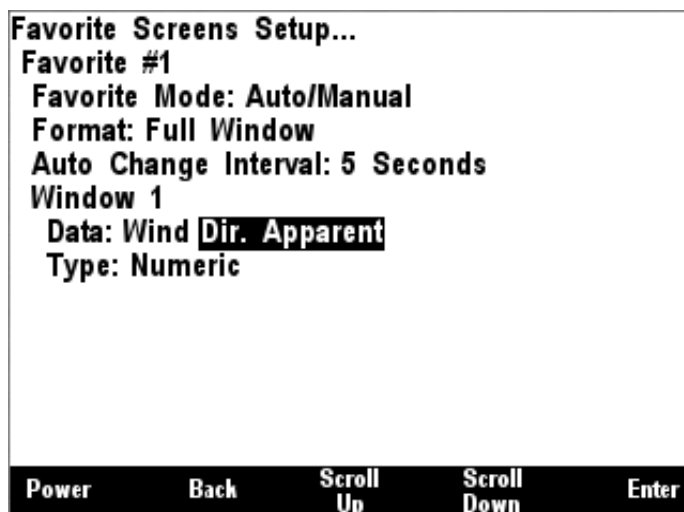
## 5.2.6.4 Window Data

The Window Data section of the menu allows you to select a particular type of data to be displayed in each part of the screen. Selecting the data to be displayed is a two-step process. First, press the Enter key (↵) and select the category of data to be displayed.



*Figure 29 – Selecting the Data Category*

Once you select the category, press the Enter key (↵) to accept this category, at which time the highlight will move to the data type field, where you can display the particular data type from the selected category to be displayed as shown in Figure 30.



*Figure 30 – Selecting the Data to be displayed*

### 5.2.6.4.1 Type

Once you have selected the particular data item to be displayed; you may select the type of data display to be used for that data item. The available display types vary depending upon the selected

data item, but may include any of the following (see Section 7 for descriptions of the available display types).

- Anchor Watch ( See Section 7.1 on page 149)
- Compass Rose (see Section 7.2 on page 149)
- Gauge (see Section 7.3 on page 150)
- GPS Status (see Section 7.4 on page 152)
- Numeric (see Section 7.5 on page 152)
- Rolling Road (see Section 7.6 on page 153)
- Line Graph (see 7.7 on page 154).
- Weather Screen (see Section 7.8 on page 155)
- Wind Rose (see Section 7.9 on page 156)
- Moon Phase (see Section 7.10 on page 156)
- Trim Tab (see Section 7.11 on page 157)
- Swing Meter (see Section 7.12 on page 157)
- Tank Gauge (see Section 0 on page 158)

#### **5.2.6.4.2 Instance**

Instance is used to specify which product on the network will be used as the source of the displayed information. For example, there may be two GPS's on the network each of which will have a unique instance assuming the network has been properly configured. You use the instance field to tell the DSM250 which GPS to use for displaying data. Most of the time, the DSM250 simply displays a single parameter from a device on the network so you will only see one "Instance" entry. There are other parameters that the DSM250 displays that are a combination of information from multiple products on the network. For example, fuel economy is a combination of fuel rate and Speed Over Ground (SOG) so you will see two "Instance" entries, one to specify the engine(s) and one to specify the GPS for SOG.

#### **5.2.6.4.3 Alert**

In setting up the Anchor Watch display type, this field is used to specify the associated Anchor Watch Alert priority. The list from which the selection is made will be limited to the list of Anchor Watch Alerts already created in the system.

#### **5.2.6.4.4 Title**

Each display type has a user defined title that is displayed above the control. The contents of the title are specified in this field. There are three options:

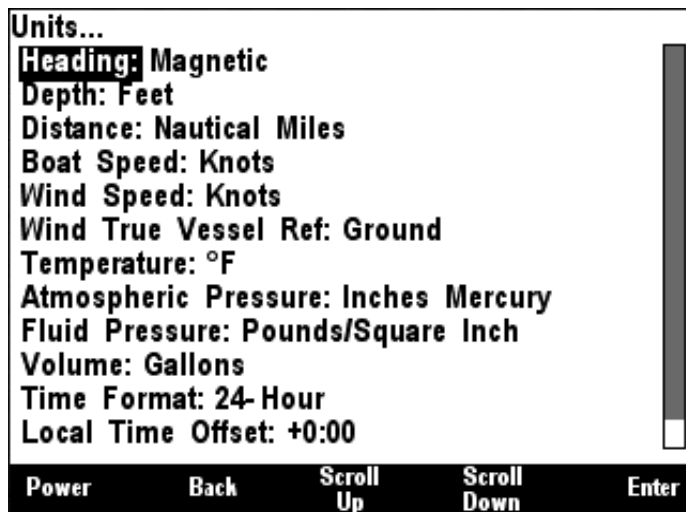
- Default – the title of the control is the same as the name of the parameter being displayed.
- Label – the label of the parameter. The label is programmed into the remote device, and will be transferred to the title when it is received from the remote device. This means that if the label of the remote device is changed, the title of the control will be automatically updated to match the new label.
- Custom – the title is entered by the user using the method described in section 3.3.4.

# DSM250 User's Manual

---

## 5.2.7 Units Menu

The Units Menu allows you to set the desired display units for the DSM250. The following sections provide more detail on the individual unit settings.



*Figure 31 – DSM250 Units Menu*

### 5.2.7.1 Heading

This menu item allows you to select whether heading, course, and bearing information is displayed in true or magnetic measurements. True heading can only be displayed if a variation is available on the NMEA 2000<sup>®</sup> bus.

If the DSM250 is not showing heading or COG (i.e., no needle on compass rose or dashes for digital displays), it's probably a good indication that variation isn't available on the network. The DSM250 can't calculate true heading given magnetic heading from a compass if variation isn't available. Likewise, the DSM250 can't calculate magnetic course given true course from a GPS if variation isn't available. You can setup a favorite screen to display variation, which will help you determine whether or not you have a product on the network broadcasting variation information (Maretron's GPS's use the World Magnetic Model to broadcast variation).

### 5.2.7.2 Depth

This menu item allows you to select the units to be used for the display of all depth-related information. Units that may be selected are the following:

- Meters
- Fathoms
- Feet

### 5.2.7.3 Distance

This menu item allows you to select the units to be used for the display of all distance-related information. Units that may be selected are the following:

- Nautical Miles
- km

- Statute Miles

#### **5.2.7.4 Boat Speed**

This menu item allows you to select the units to be used for the display of all boat speed-related information. Units that may be selected are the following:

- Knots
- Miles/Hour
- Km/Hour
- Meters/second

#### **5.2.7.5 Wind Speed**

This menu item allows you to select the units to be used for the display of all wind speed-related information. Units that may be selected are the following:

- Knots
- Miles/Hour
- Km/Hour
- Beaufort
- Meters/second

#### **5.2.7.6 Wind True Vessel Ref.**

This menu item allows you to select whether the true wind direction and speed referenced to the vessel are relative to the water or the ground. Sailors are generally interested in measurements relative to the water while power boaters are interested in measurements relative to the ground. Station is for home applications (i.e., fixed mounting location unlike a vessel that changes direction). Formats that may be selected are the following:

- Water
- Ground
- Station

#### **5.2.7.7 Temperature**

This menu item allows you to select the units to be used for the display of all temperature-related information. Units that may be selected are the following:

- °F
- °C

#### **5.2.7.8 Atmospheric Pressure**

This menu item allows you to select the units to be used for the display of atmospheric (barometric) pressure. Units that may be selected are the following:

- Inches Mercury (in Hg)
- Bar
- Millibars

# DSM250 User's Manual

---

- Millimeters Mercury (mm Hg)
- kPa

## 5.2.7.9 Fluid Pressure

This menu item allows you to select the units to be used for the display of fluid pressure. Units that may be selected are the following:

- Pounds/Square Inch (PSI)
- kPa
- Bar

## 5.2.7.10 Volume

This menu item allows you to select the units to be used for the display of all liquid volume-related information. Units that may be selected are the following:

- Liters
- Imperial Gallons (UK Gallons)
- Gallons (US Gallons)

## 5.2.7.11 Time Format

This menu item allows you to select whether measurements indicating a time of day are displayed in 12-Hour (AM/PM) format or 24-Hour (military) format.

## 5.2.7.12 Local Time Offset

This menu item allows you to indicate the offset of local time relative to Universal Time, Coordinated (UTC, also known as Greenwich Mean Time, or GMT), in hours and minutes. For instance, Eastern Standard Time (EST) would use an offset value of -5:00.

## 5.2.7.13 Date Format

This menu item allows you to select the format of any displayed dates. Formats that may be selected are the following:

- MM-DD-YYYY (01-31-2005)
- DD-MM-YYYY (31-01-2005)
- MMM-DD-YYYY (JAN-31-2005)
- DD-MMM-YYYY (31-JAN-2005)



## 6 Device Configuration

The “Device Configuration...” menu enables you to configure certain types of devices on the NMEA 2000® network. Devices that may be configured using the DSM250 include the following:

**Bennett EP-30** – Calibrate trim tabs.

**Maretron Alternating Current Monitor (ACM100)** – Set circuit type, device type, instance number, and label. Reset the total energy recorded.

**Maretron Annunciator (ALM100)** – Set the Data Instance Number, and the Label. Test the alarm.

**Maretron Direct Current Monitor (DCM100)** – Set the Battery Type, and calibrate the current sensor zero offset.

**Maretron Monochrome Display (DSM200)** – allows configuration of other DSM200s on the network

**Maretron Color Display (DSM250)** – allows configuration of other DSM250s on network

**Maretron Depth/Speed/Temp. Transducer (DST100)** – set transducer offset, zero trip distance log

**Maretron Engine Monitoring System (EMS100)** – set the gauge types for Boost Pressure, Drive Trim, Oil Pressure and Water Temperature. Preset the Engine Hours

**Maretron GPS Antenna/Receiver (GPS100)** – enable and disable WAAS functionality, set the GPS mode, program the elevation, PDOP and SNR masks, set the antenna altitude, force a cold start, enable/disable individual PGN transmission, and reset the unit back to its factory defaults.

**Maretron J1939 to NMEA 2000 Gateway (J2K100)** – set J1939 node address, set NMEA 2000® engine/transmission instance, enable pass-through of J1939 diagnostic messages, and enable/disable individual NMEA 2000® PGN transmissions.

**Maretron Rudder Angle Adapter (RAA100)** – Set rudder number, operating mode, and calibrate rudder position.

**Maretron Run Indicator Monitor (RIM100)** – Set Data Instance for the device, and labels for the device and each channel.

**Maretron Switch Indicator Monitor (SIM100)** – Set Data Instance for the device, and labels for the device and each channel. Set each channel mode.

**Maretron Solid Sate Compass (SSC200)** – set installation offset, perform magnetic deviation calibration, check magnetic deviation calibration status, invert installation, configure magnetic variation settings, setup NMEA0183 interface, program rate of turn damping, zero the rate-of-turn offset, and enable/disable individual NMEA 2000® PGN transmissions.

**Maretron Tank Level Adapter (TLA100)** – Set tank type and tank number, set operating mode, set tank capacity, and calibrate for irregular shaped tanks.

**Maretron Tank Level Monitor Shallow (TLM100)** – Set tank type and tank number, set operating mode, set tank capacity, and calibrate for irregular shaped tanks.

**Maretron Tank Level Monitor Gasoline (TLM150)** – Set tank type and tank number, set operating mode, set tank capacity, and calibrate for irregular shaped tanks.

**Maretron Tank Level Monitor Deep (TLM200)** – Set tank type and tank number, set operating mode, set tank capacity, and calibrate for irregular shaped tanks.

**Maretron Temperature Monitor (TMP100)** – Set device label and channel instance, temperature source (type) and label.

**Maretron NMEA 2000 to USB gateway (USB100)** – allows configuration of USB100s on network

# DSM250 User's Manual

**Maretron Ultrasonic Wind and Weather Station (WSO100)** – set installation offset, set wind damping rates, and enable/disable individual NMEA 2000® PGN transmissions.

More device types will be included in future firmware releases.

In each case, the contents of the Device Configuration menus may vary depending on the version of the firmware within the device.

The “**Device Configuration...**” menu is shown in Figure 32.

Configuration...					
Device Configuration...					
NA	Manufacturer	Model	SN#	HW#	SW#
21	Maretron	GPS100	1110001	1.1	1.1
62	Maretron	SSC200	1120002	1.0	1.9
03	Maretron	DST100	1130003	1.0	1.0
54	Maretron	USB100	1160004	1.0	1.6
15	Maretron	DSM200	1100005	1.2	1.10
86	Maretron	WSO100	1200006	1.0	1.0.0
B9	Maretron	TLA100	1260009	1.0	1.0
C0	Maretron	RAA100	1280000	1.0	1.0
D8	Lowrance	EP-30	5550008	1.0	1.0

Power      Back      Scroll Up      Scroll Down      Enter

*Figure 32 – Device Configuration Screen*

The “**NA**” column of the menu displays the node address the device is using.

The “**Manufacturer**” column of the menu displays the manufacturer of the device.

The “**Model**” column displays the model number of the device.

The “**SN#**” column displays the serial number of the device, so that any of two or more devices of the same manufacturer and model number may be distinguished from one another.

The “**HW**” column shows the device hardware version.

The “**SW**” column shows the device software version (firmware version).

## 6.1 Bennett EP-30 (NMEA1) Trim Tabs Configuration

This describes the configuration of the Bennett EP-30 trim tabs firmware version 1.0.7 (“NMEA1” NMEA 2000 Trim Tab Indicator Kit). The EP-30 configuration menu is shown below in Figure 33 below, and currently has the single entry “Trim Tabs Calibration...”.

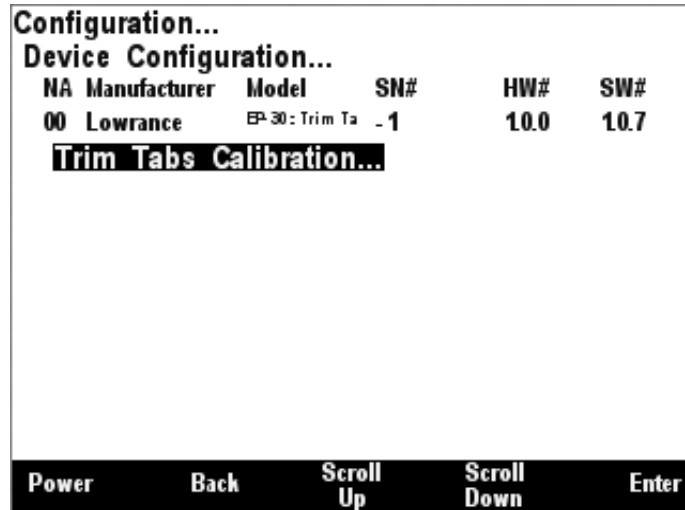


Figure 33 –EP-30 Trim Tabs Configuration Screen

### 6.1.1 Trim Tabs Calibration

The Bennett EP-30 (NMEA1) trim tabs calibration opening screen is shown in Figure 34 below. The first step in calibration is to move both trim tabs to the full up position, and then press the Accept (⏏) key to begin the calibration process. You may also elect to abort the calibration process at this time by pressing the Abort (⏏) key.

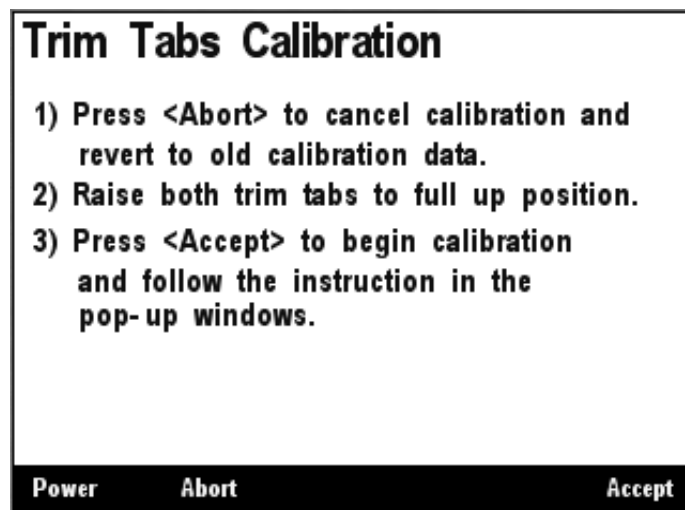
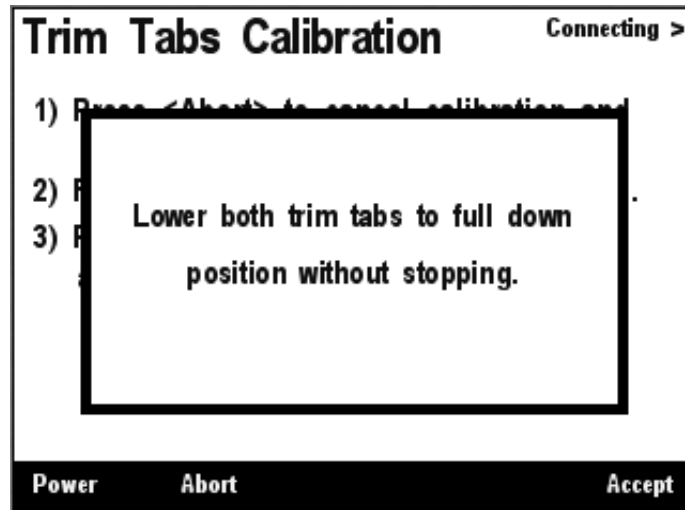


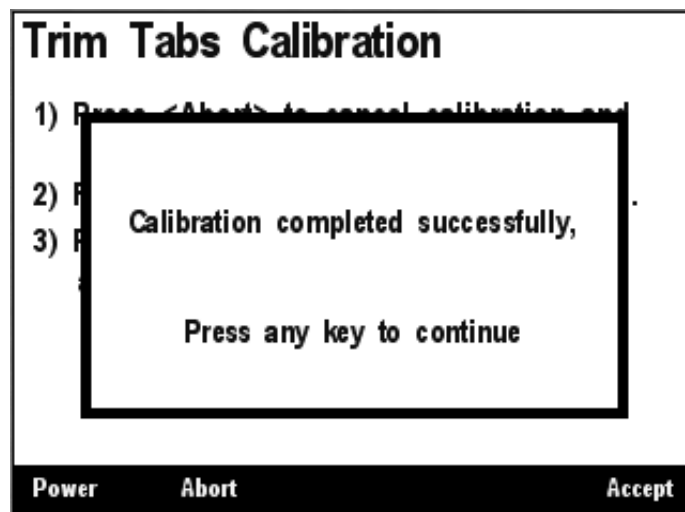
Figure 34 –EP-30 Trim Tabs Calibration Opening Screen

After you press the Accept (⏏) key, a screen, shown in Figure 35 below, appears, instructing you to now lower both trim tabs to the full down position. It is important that you do this without stopping in order for the calibration process to succeed.



**Figure 35 –EP-30 Intermediate Calibration Screen**

After you have lowered both trim tabs to their full down position and a few seconds have elapsed, the screen shown in Figure 36 below should appear, indicating that the calibration of the trim tab sensors has completed successfully. You may now press any key to return to the previous menu.



**Figure 36 –EP-30 Calibration Success Message**

## 6.2 Maretron ACM100 Configuration

This describes the configuration of the Maretron ACM100 firmware version 1.0.6.

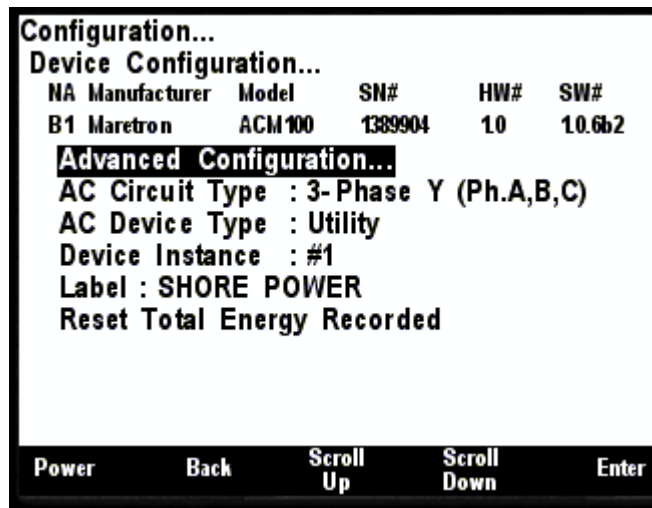


Figure 37 – ACM100 Configuration Screen

### 6.2.1 Advanced Configuration

Advanced Configuration changes some complex parameters within the device, and should only be performed by an advanced user. Typically advanced configuration is only done at installation and should not need to be done while at sea.

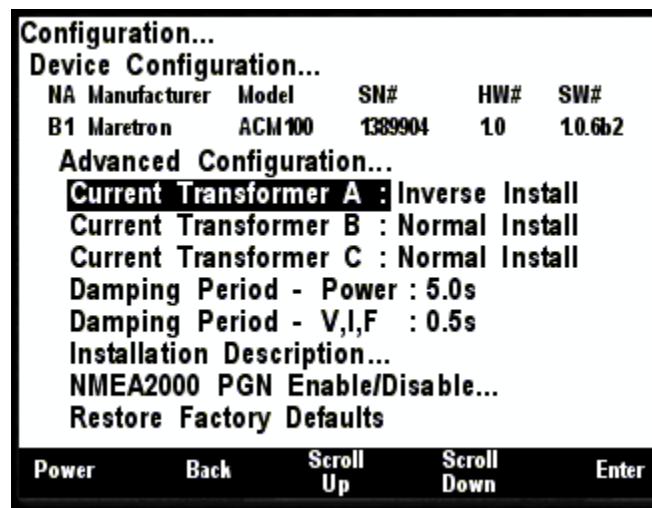


Figure 38- ACM100 Advanced Configuration Screen

#### 6.2.1.1 Current Transformer A

If you notice that the power measurements of phase A are negative when they should be positive, or vice-versa, then the current transformer has been installed backwards. If this happens, then instead of reconnecting the current transformer, you may change the value of this parameter from the default value of "Normal Install" to "Inverse Install" to correct for this.

Valid options are:

# DSM250 User's Manual

---

- **Inverse Install**
- **Normal Install**

Use the **Scroll Up** and **Scroll Down** buttons to select the correct option, and then press **Enter** to save the value.

## 6.2.1.2 Current Transformer B

If you notice that the power measurements of phase B are negative when they should be positive, or vice-versa, then the current transformer has been installed backwards. If this happens, then instead of reconnecting the current transformer, you may change the value of this parameter from the default value of "Normal Install" to "Inverse Install" to correct for this.

Valid options are:

- **Inverse Install**
- **Normal Install**

Use the **Scroll Up** and **Scroll Down** buttons to select the correct option, and then press **Enter** to save the value.

## 6.2.1.3 Current Transformer C

If you notice that the power measurements of phase C are negative when they should be positive, or vice-versa, then the current transformer has been installed backwards. If this happens, then instead of reconnecting the current transformer, you may change the value of this parameter from the default value of "Normal Install" to "Inverse Install" to correct for this.

Valid options are:

- **Inverse Install**
- **Normal Install**

Use the **Scroll Up** and **Scroll Down** buttons to select the correct option, and then press **Enter** to save the value.

## 6.2.1.4 Damping Period – Power

If you feel that the monitored Power parameters are changing too quickly or too slowly on the display, you can adjust the damping that is applied to the output readings by adjusting this parameter. The default damping period is 5 seconds. You may change it to a value in the range of 0.2 seconds to 10 seconds. Use the **Increase** and **Decrease** buttons to select the correct option, and then press **Enter** to save the value.

## 6.2.1.5 Damping Period – V, I, F

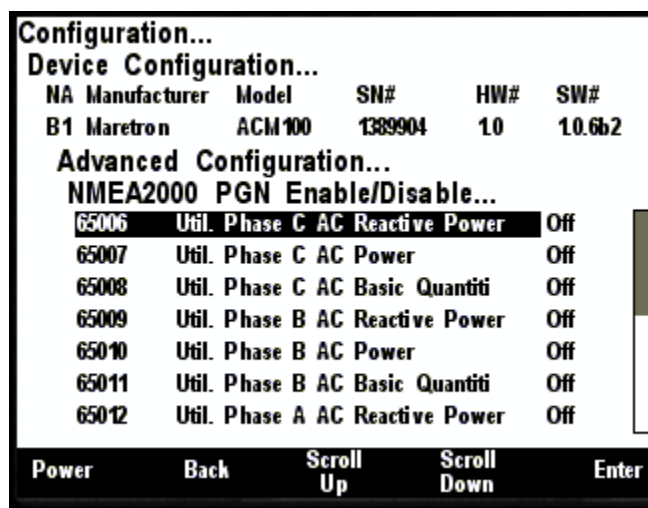
If you feel that the monitored Voltage, Current, and Frequency parameters are changing too quickly or too slowly on the display, you can adjust the damping that is applied to the output readings by adjusting this parameter. The default damping period is 0.5 seconds. You may change it to a value in the range of 0.2 seconds to 10 seconds. Use the **Increase** and **Decrease** buttons to select the correct option, and then press **Enter** to save the value.

## 6.2.1.6 Installation Description

This entry allows you to modify the NMEA 2000 installation description text strings. You can enter any information you like here, such as the date the unit was installed, or the location in which it was installed, for later reference. Tools such as Maretron N2KAnalyzer allow you to view these values later. See section 3.3.4 for details on how to enter a textual value.

## 6.2.1.7 NMEA2000 PGN Enable/Disable

The ACM100 Alternating Current transmits a number of the NMEA2000® PGNs which can be turned on or turned off by the DSM250 display. For reasons of compatibility with older NMEA2000 devices, some of these PGNs are redundant; disabling these PGNs will reduce the amount of traffic on the NMEA2000® bus. Pressing the **Enter** key with “NMEA2000 PGN Enable/Disable...” menu item selected causes the DSM250 to display the following .



*Figure 39 – ACM100 NMEA 2000® PGN Enable/Disable Screen*

You can enable or disable the transmission of a PGN message, or set the frequency of transmission of the message by pressing the Enter key (↵) on the message to be configured. Options are:

- **Off** – The PGN will not be transmitted
- **On** – The PGN will be transmitted at its default NMEA2000 rate.
- **0.5s...5s** – The PGN will be transmitted at the interval specified.

Select the required option using the **Scroll Up** and **Scroll Down** keys followed by the **Enter** key.

## 6.2.1.8 Restore Factory Defaults

This option restores all settings on the ACM100 device to their factory default state.

## 6.2.2 AC Circuit Type

You must configure the ACM100 as to what type of AC circuit connection it is monitoring. The allowable values for this parameter are as follows:

- **Single-Phase (Phase A)** – use this value when power is connected via a single hot wire and a single neutral wire (a typical 110VAC connection in the US, or 220VAC connection in Europe).

# DSM250 User's Manual

---

- **Single-Phase (Phase A, B)** – use this value when power is connected via two hot wires (180° out of phase with each other) and single neutral wire from a single phase of a transformer (a typical 220VAC connection in the US).
- **3-Phase Y (Phase A, B, C)** – use this value when power is connected via the three hot wires (120° out of phase with each other) and single neutral wire from a three-phase “Y” connected circuit.

## 6.2.3 AC Device Type

You must configure the ACM100 as to what type of AC source it is monitoring. The allowable values for this parameter are as follows:

- **Generator** (default) – use this value when you are monitoring the output of an onboard generator.
- **Utility** – use this value when you are monitoring shore power.
- **Bus** – use this value if you are monitoring power flowing across a cable that is not located directly at the output of a generator or a shore power connection (e.g., an AC selection switch might have as an input the shore power and another input from the generator, connecting the ACM100 at the output of the AC selection switch would require the ACM100 to be configured as “Bus”).

## 6.2.4 Device Instance

This entry allows you to program the NMEA 2000 device instance for the unit. You usually will not need to modify the default value of “0” unless you have multiple ACM100s on the network.

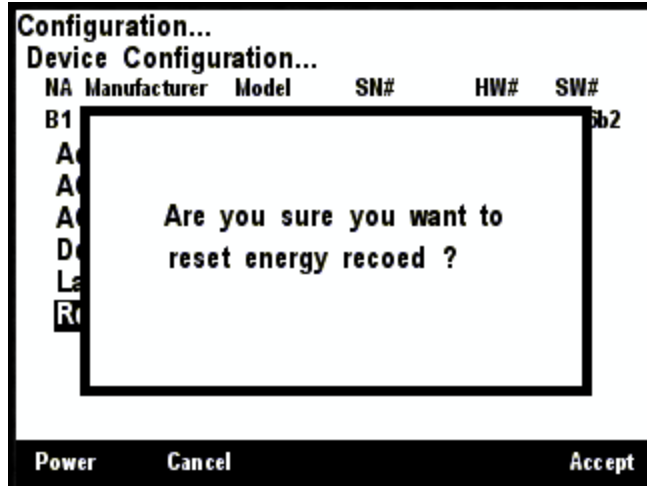
## 6.2.5 Label

A device label may be assigned to the ACM100 as an aid to identifying the device over the network (i.e., Shore Power or Port Generator, etc.). Typically this label will describe the equipment to which the ACM100 is connected. See section 3.3.4 for details on how to enter a textual value.

## 6.2.6 Reset Total Energy Recorded

The ACM100 will accumulate the total amount of energy produced by a Generator or a Utility. Pressing the Enter key, while this item is highlighted will start the process to reset this value to zero. The following confirmation screen is displayed.



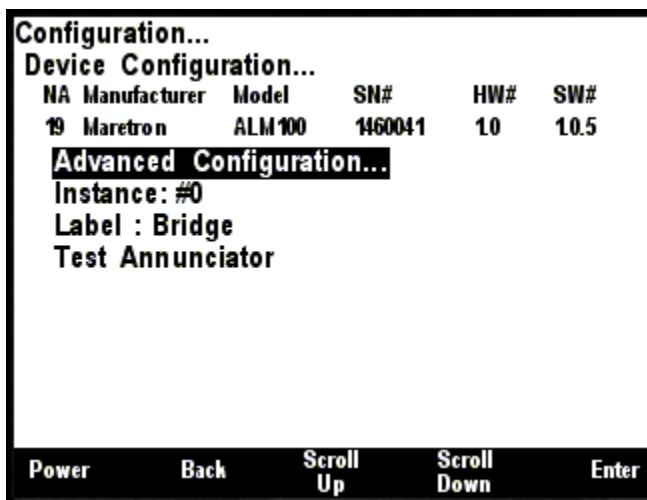


**Figure 40 – Reset Total Energy Recorded Confirmation Screen**

Press **Accept** to reset the value, or **Cancel** to return to the previous screen.

## 6.3 Maretron ALM100 Configuration

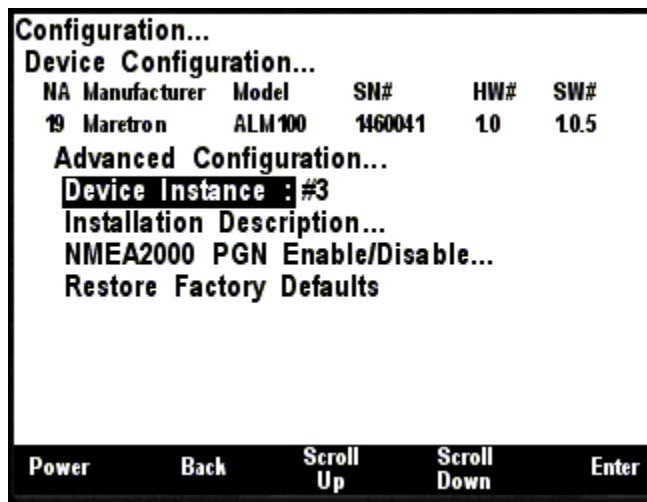
This describes the configuration of the Maretron ACM100 firmware version 1.0.5.



*Figure 41 – ALM100 Configuration Screen*

### 6.3.1 Advanced Configuration

Advanced Configuration changes some complex parameters within the device, and should only be performed by an advanced user. Typically advanced configuration is only done at installation and should not need to be done while at sea.



*Figure 42 – ALM100 Advanced Configuration Screen*

#### 6.3.1.1 Device Instance

This entry allows you to program the NMEA 2000 device instance for the unit. You usually will not need to modify the default value of “0” unless you have multiple units on the network.

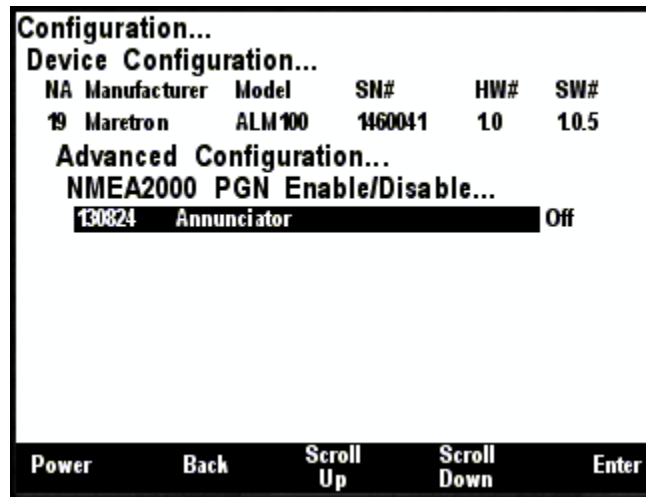
#### 6.3.1.2 Installation Description

This entry allows you to modify the NMEA 2000 installation description text strings. You can enter any information you like here, such as the date the unit was installed, or the location in which it was

installed, for later reference. Tools such as Maretron N2KAnalyzer allow you to view these values later. See section 3.3.4 for details on how to enter a textual value.

### 6.3.1.3 NMEA2000 PGN Enable/Disable

The ALM100 Annunciator Module transmits the NMEA2000 PGN #130824 which can be turned on or turned off by the DSM250 display. Pressing the **Enter** key with “NMEA2000 PGN Enable/Disable...” menu item selected causes the DSM250 to display the following screen.



**Figure 43 –ALM100 NMEA 2000® PGN Enable/Disable Screen**

You can enable or disable the transmission of the Annunciator message, or set the frequency of transmission of the message by pressing the Enter key (↵) on the message to be configured. Options are:

- **Disable** – The Annunciator message will not be transmitted
- **Default** – The Annunciator message will be transmitted at its default NMEA2000 rate, and each time the value changes.
- **0.5s...5s** – The Annunciator message will be transmitted at the period specified, and each time the value changes.

Select the required option using the **Scroll Up** and **Scroll Down** keys followed by the **Enter** key.

### 6.3.1.4 Restore Factory Defaults

This option restores all settings on the device to their factory default state.

## 6.3.2 Instance

From here the instance number used in the Annunciator message may be set.

### 6.3.3 Label

A label may be assigned to the ALM100 as an aid to identifying the device over the network. Typically this label will describe the location of the ALM100.

See section 3.3.4 for details on how to enter a textual value.

## 6.3.4 Test Annunciator

The Annunciator may be tested by scrolling the cursor to highlight this entry and then pressing the **Enter** button. The ALM100 will emit a single beep.

## 6.4 Maretron DCM100 Configuration

This describes the configuration of the Maretron ACM100 firmware version 1.0.4.

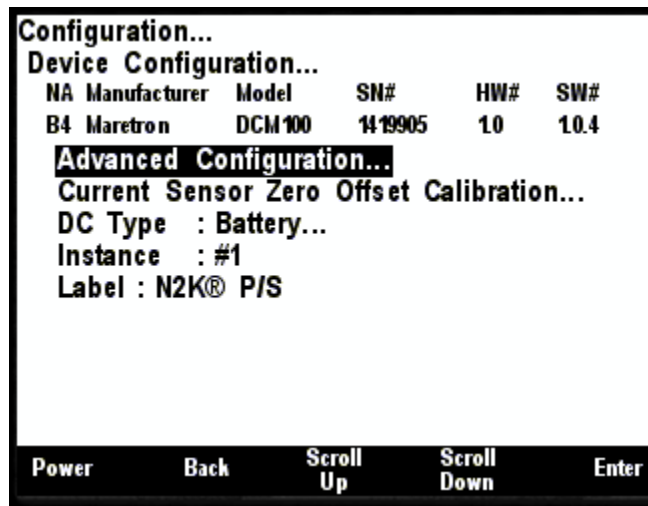


Figure 44 – DCM100 Configuration Screen

### 6.4.1 Advanced Configuration

Advanced Configuration changes some complex parameters within the device, and should only be performed by an advanced user. Typically advanced configuration is only done at installation and should not need to be done while at sea.

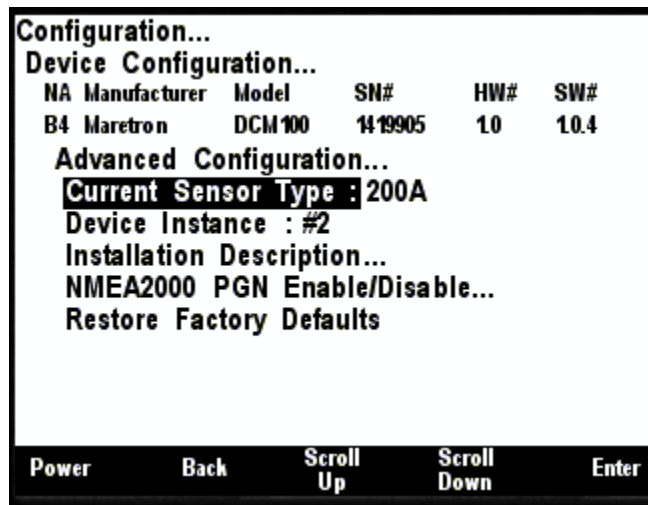


Figure 45 – DCM100 Advanced Configuration Screen

#### 6.4.1.1 Current Sensor Type

Three different current sensors may be attached to the DCM100. Options are:

- **200A** – A 200 Amp Current Transducer is connected to the DCM100. This has the part number LEMHTA200-S.
- **400A** – A 400 Amp Current Transducer is connected to the DCM100. This has the part number LEMHTA400-S.

# DSM250 User's Manual

- **600A** – A 600 Amp Current Transducer is connected to the DCM100. This has the part number LEMHTA600-S.

Select the required transducer using the **Scroll Up** and **Scroll Down** keys followed by the **Enter** key.

## 6.4.1.2 Device Instance

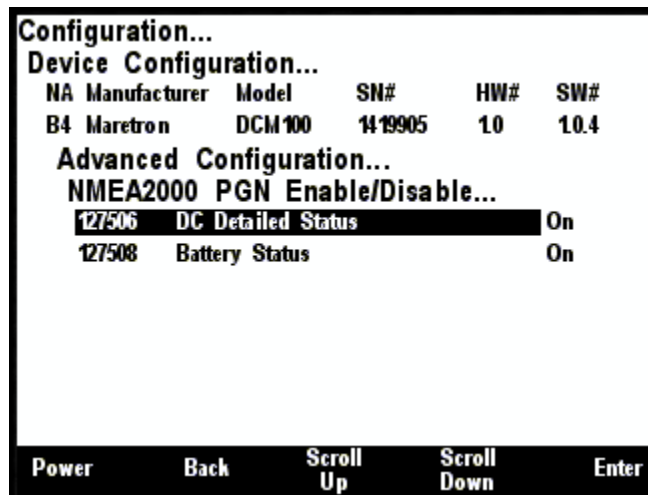
This entry allows you to program the NMEA 2000 device instance for the unit. You usually will not need to modify the default value of “0” unless you have multiple units on the network.

## 6.4.1.3 Installation Description

This entry allows you to modify the NMEA 2000 installation description text strings. You can enter any information you like here, such as the date the unit was installed, or the location in which it was installed, for later reference. Tools such as Maretron N2KAnalyzer allow you to view these values later. See section 3.3.4 for details on how to enter a textual value.

## 6.4.1.4 NMEA2000 PGN Enable/Disable

The DCM100 Annunciator Module transmits the NMEA2000 PGNs #127506 and 127508 which can be turned on or turned off by the DSM250 display. Pressing the **Enter** key with “NMEA2000 PGN Enable/Disable...” menu item selected causes the DSM250 to display the following screen.



**Figure 46 –DCM100 NMEA 2000® PGN Enable/Disable Screen**

You can enable or disable the transmission of the these messages, or set the frequency of transmission of the message by pressing the Enter key (⏎) on the message to be configured. Options are:

- **Disable** – The message will not be transmitted
- **Default** – The message will be transmitted at its default NMEA2000 rate.
- **1.0s...5.0s** – The message will be transmitted at the period specified.

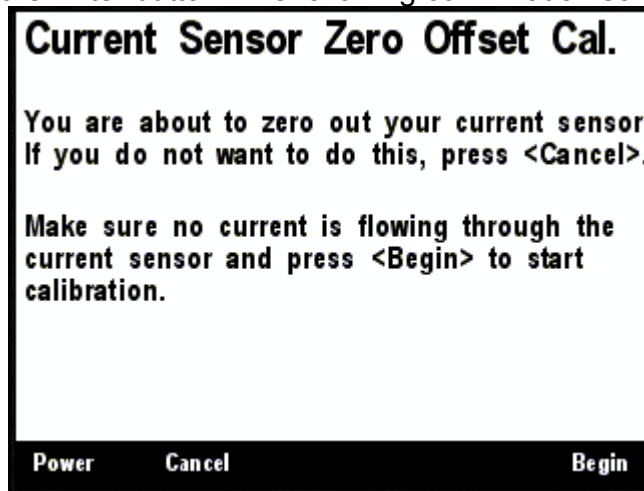
Select the required option using the **Scroll Up** and **Scroll Down** keys followed by the **Enter** key.

## 6.4.1.5 Restore Factory Defaults

This option restores all settings on the device to their factory default state.

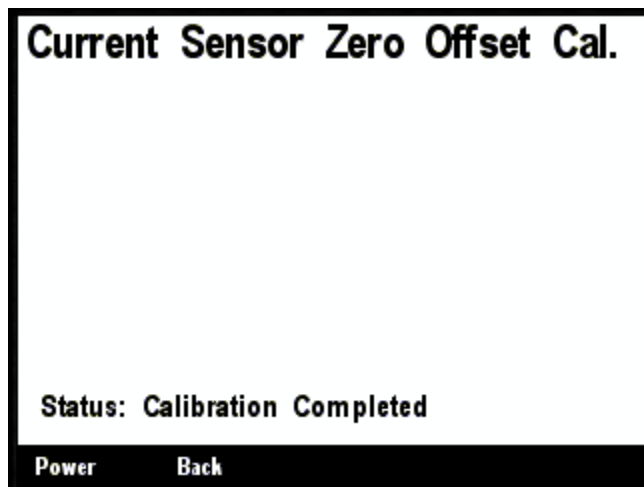
## 6.4.2 Current Sensor Zero Offset Calibration

The DCM100 is shipped with a Hall-effect current sensor. In order to match the DCM100 unit and the sensor to one another and ensure maximum accuracy, you should perform this calibration step while there is no current flowing through the current sensor. Move the highlight bar to the Current Sensor Zero Offset Calibration and press the Enter button. The following confirmation screen will be displayed:



*Figure 47 – Current Sensor Zero Offset Calibration Confirmation Screen*

Make sure that no current is flowing through the sensor, and press **Begin** to execute the calibration process or **Cancel** to return to the previous menu. When the calibration is complete, the following screen will be displayed.



*Figure 48 - Current Sensor Zero Offset Calibration Complete Screen*

Press the **Back** button to return to the previous menu.

# DSM250 User's Manual

---

## 6.4.3 DC Type

You can configure the DCM100 as to what type of DC power source it is monitoring. With the exception of the "Battery" type, the value of this parameter is used only for reporting the power source type over the NMEA 2000 network. However, if you select the "Battery" type, many battery-related options become available.

The following DC Types are selectable:

- Battery
- Alternator
- Converter
- Solar Cell
- Wind Generator

If the DC Type is set to battery, then the following options may be entered to characterize the battery and allow the estimation of remaining charge etc.

### 6.4.3.1 Battery Type

The available battery types are

- Flooded/Wet
- Gel
- AGM
- Other

Selecting one of these types causes the remaining parameters to be set to appropriate default values.

### 6.4.3.2 Nominal Voltage

You may program here the nominal voltage of the battery, which is used only for reporting over the NMEA 2000 network. Available choices are 6, 12, 24, 32, 36, 42, and 48 Volts.

### 6.4.3.3 Equalization

You may indicate here whether or not the battery supports equalization. This is used only for reporting over the NMEA 2000 network. Available choices are

- Supported
- Not Supported

### 6.4.3.4 Temperature Coefficient

The capacity of a battery generally increases with increasing temperature. So that the DCM100 can properly calculate the battery's state of charge, program this parameter with the increase in battery capacity, in percent, per increase in temperature, in degrees Celsius. The temperature coefficient can be set to a value between 0%/°C – 5%/°C.

### 6.4.3.5 Peukert Exponent

The Peukert Exponent for the battery can be set to a value between 1.0 and 1.5. Please refer to Section 4.8 on page 11 for details.



### 6.4.3.6 Charge Efficiency Factor

The Charge Efficiency Factor for the battery can be set to a value between 5% and 100%. Please refer to Section 4.6.1 on page 11 for details.

### 6.4.3.7 Fully Charged Voltage

In order for the DCM100 to determine when a battery is fully charged, it uses three parameters. The “Fully Charged Voltage” indicates the value voltage at which the battery is considered fully charged if the battery voltage remains above this value and the battery current remains below the “Fully Charged Current” for the amount of time defined by the “Fully Charged Time” parameter.

### 6.4.3.8 Fully Charged Current

In order for the DCM100 to determine when a battery is fully charged, it uses three parameters. The “Fully Charged Voltage” indicates the value voltage at which the battery is considered fully charged if the battery voltage remains above this value and the battery current remains below the “Fully Charged Current” for the amount of time defined by the “Fully Charged Time” parameter.

### 6.4.3.9 Fully Charged Time

In order for the DCM100 to determine when a battery is fully charged, it uses three parameters. The “Fully Charged Voltage” indicates the value voltage at which the battery is considered fully charged if the battery voltage remains above this value and the battery current remains below the “Fully Charged Current” for the amount of time defined by the “Fully Charged Time” parameter.

### 6.4.3.10 Battery Temperature

In order for the DCM100 to properly determine battery capacity and state of charge, it must know the temperature of the battery. If you are using a TR3K temperature sensor attached to the battery, you should set this parameter to “Sensor”. Otherwise, if no temperature sensor is available, you can set this parameter to the estimated battery temperature, between -25°C and 125°C.

### 6.4.3.11 Time Remaining Floor

The DCM100 calculates the time, given the current being discharged from the battery, before the battery becomes discharged. By default, the DCM100 considers a battery to be discharged when its state of charge reaches the “Time Remaining Floor” value, which is by default set to 50%. If you desire to use some other state of charge value for the “Time Remaining Floor”, you may change this parameter to the desired value.

### 6.4.3.12 Time Remaining Averaging Period

If loads on the battery are switching on and off frequently, the battery time remaining value calculated by the DCM100 can vary significantly. You may change the time over which current readings are averaged by changing this parameter anywhere in the range of 1 second to 32 minutes.

### 6.4.3.13 Zero Current Threshold

The current sensor reading can drift slightly at zero current, depending on temperature. Over a long period of time, this can cause the DCM100 to calculate that a battery is discharging slowly, even though it is not. The Zero Current Threshold parameter indicates a reading from the current sensor below which no current is considered to be flowing into or out of the battery.

# DSM250 User's Manual

---

## 6.4.4 Instance

This entry allows you to program the NMEA 2000 device instance for the unit. You usually will not need to modify the default value of "0" unless you have multiple units on the network.

## 6.4.5 Label

A label may be assigned to the DCM100 as an aid to identifying the device over the network. Typically this label will describe the battery or device which the DCM100 is monitoring. See section 3.3.4 for details on how to enter a textual value.

## 6.5 Maretron DSM200 Configuration

You can use the DSM250 to configure other remotely-located DSM200 units by using the Remote DSM200 configuration menu shown in Figure 49 below. This describes the configuration of the Maretron DSM200 firmware version 1.10. There is one configurable item for the remote DSM200 configuration and that is “Remote Device Selection...”.

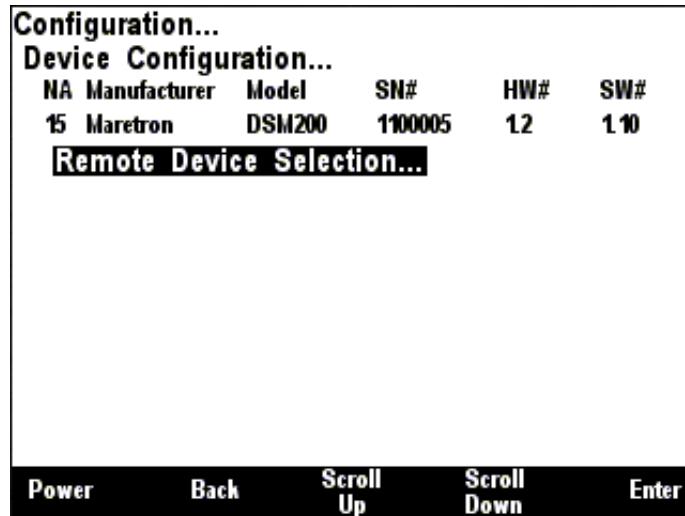


Figure 49 – DSM200 Remote Configuration Screen

### 6.5.1 Remote Device Selection

A DSM250 unit can be used to configure a remote DSM200 to set which NMEA 2000® devices are selected for display on the remote DSM200 unit. In this manner, multiple devices of the same type may be used on a NMEA 2000® network in a fail-safe configuration. For example, a certain compass unit out of several may be selected for display on the remote DSM200. The “Remote Device Selection...” menu for an example network configuration can be seen in Figure 50 below.

**WARNING:** Do not select multiple devices of the same type for display. This will result in multiple and possibly conflicting readings.

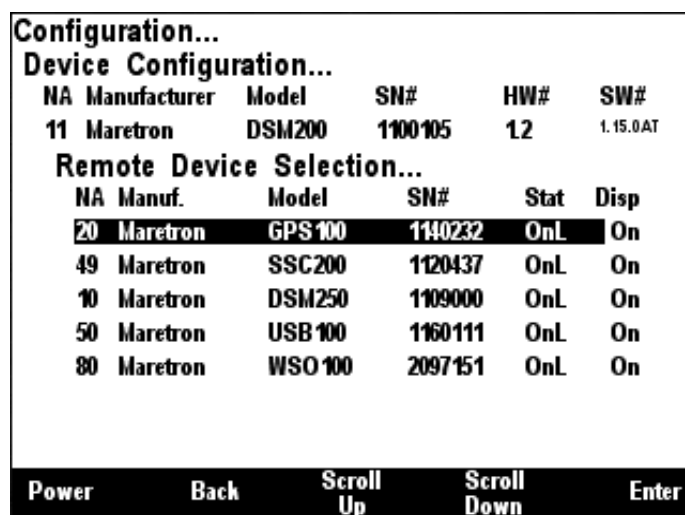


Figure 50 – DSM200 Remote Device Selection Screen

# DSM250 User's Manual

---

The “**NA**” column of the menu displays the node address the device is using.

The “**Manuf.**” column of the menu displays the manufacturer of the device.

The “**Model**” column displays the model number of the device.

The “**SN#**” column displays the serial number of the device, so that any of two or more devices of the same manufacturer and model number may be distinguished from one another.

The “**Stat**” column indicates whether the device is currently connected to the bus and is responding to queries (“Online”), or has been disconnected from the bus, has lost power, or for some other reason is not responding to queries (“Offline”).

The “**Disp**” column indicates whether data from that particular device is accepted for display by the remote DSM200 (“On”) or that the remote DSM200 ignores data transmitted by this device (“Off”). By scrolling to the device and pressing the Enter key (⏎), you may then use the Scroll Up (⬆) and Scroll Down (⬇) keys to toggle the “Display” status for this particular device. Once you are satisfied with the state of the “Display” setting, press the Enter key (⏎) to accept the setting.

The remote DSM200 will retain information on devices that have been removed from the bus or powered down (“Offline”) so that when they are placed back on the bus, they will assume their prior “Display” setting.

## 6.6 Maretron DSM250 Configuration

You can use the DSM250 to configure other remotely-located DSM250 units by using the Remote DSM250 configuration menu as shown in Figure 51 below. This describes the configuration of the Maretron DSM250 firmware version 1.3.10. There are three configurable items for the remote DSM250: “Remote Device Selection...”, “Copy device selection from local display”, and “Copy favorite settings from local display”.

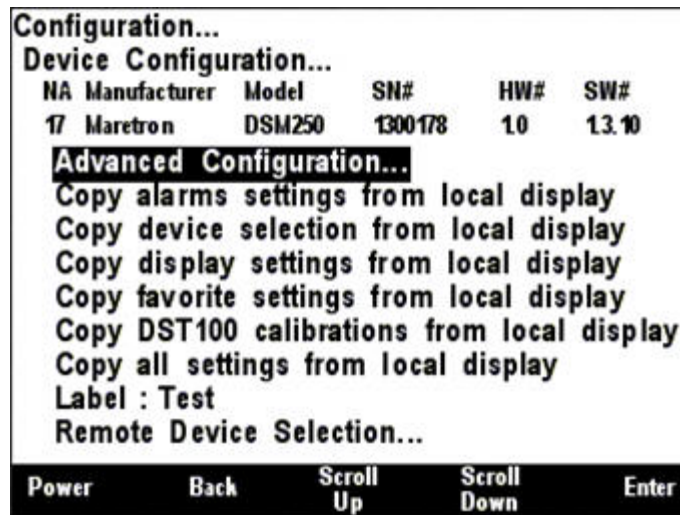
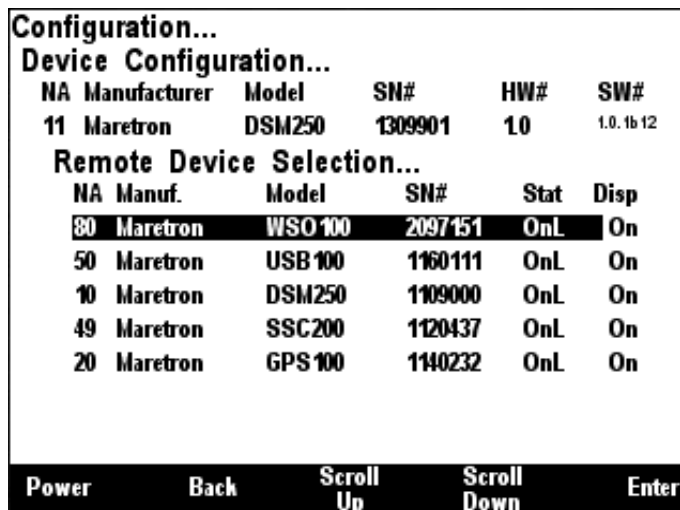


Figure 51 – DSM250 Remote Configuration Screen

### 6.6.1 Remote Device Selection

A DSM250 unit can be used to configure a remote DSM250 to set which NMEA 2000® devices are selected for display on the remote DSM250 unit. In this manner, multiple devices of the same type may be used on a NMEA 2000® network in a fail-safe configuration. For example, a certain compass unit may be selected from several available compasses for display on the remote DSM250. The Remote DSM250 Device Selection Menu for an example network configuration can be seen in Figure 52 below.

**WARNING:** Do not select multiple devices of the same type for display. This will result in multiple and possibly conflicting readings.



# DSM250 User's Manual

*Figure 52 – DSM250 Remote Device Selection Screen*

The “**NA**” column of the menu displays the node address the device is using.

The “**Manuf.**” column of the menu displays the manufacturer of the device.

The “**Model**” column displays the model number of the device.

The “**SN#**” column displays the serial number of the device, so that any of two or more devices of the same manufacturer and model number may be distinguished from one another.

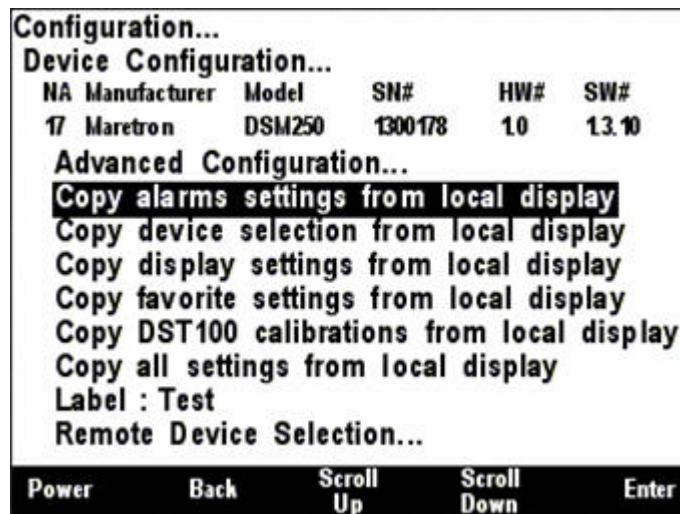
The “**Stat**” column indicates whether the device is currently connected to the bus and is responding to queries (“Online”), or has been disconnected from the bus, has lost power, or for some other reason is not responding to queries (“Offline”).

The “**Disp**” column indicates whether data from that particular device is accepted for display by the remote DSM250 (“On”) or that the remote DSM250 ignores data transmitted by this device (“Off”). By scrolling to the device and pressing the Enter key (↵), you may then use the Scroll Up (↑) and Scroll Down (↓) keys to toggle the “Display” status for this particular device. Once you are satisfied with the state of the “Display” setting, press the Enter key (↵) to accept the setting.

The remote DSM250 will retain information on devices that have been removed from the bus or powered down (“Offline”) so that when they are placed back on the bus, they will assume their prior “Display” setting.

## 6.6.2 Copy alarms settings from local display

It is possible to copy the alarm settings from a DSM250 unit to a remotely located DSM250. This should be done with care because if more than one Alert Source is monitoring the same parameter, then multiple alerts will be generated when the parameter goes out of bounds, and each one will need to be independently accepted or cancelled. Any alarms existing on the remote DSM250 will be deleted. Figure 53 below shows this menu item highlighted.



*Figure 53 - DSM250 Copy alarms settings from local display*

After you select this menu item and press **Enter**, the alarm settings from this DSM250 unit will be copied to the selected remote DSM250 unit.



### 6.6.3 Copy device selection from local display

Since it is normally desirable for all DSM250 units on a network to display the same sensors, it is possible to copy the device selection settings from a DSM250 unit to a remotely located DSM250. In this way, it is possible to make all device selection changes on a single DSM250 unit and then quickly and conveniently duplicate these new device selection settings on other DSM250 units attached to the network. Figure 54 below shows this menu item highlighted.

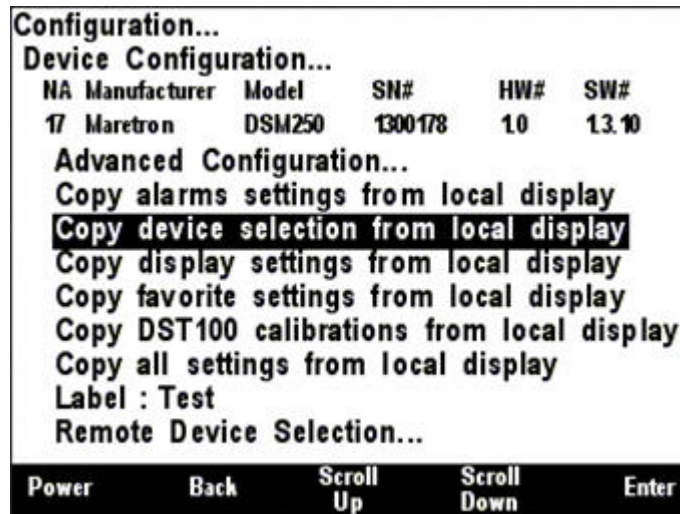


Figure 54 – DSM250 Copy device selection from local display

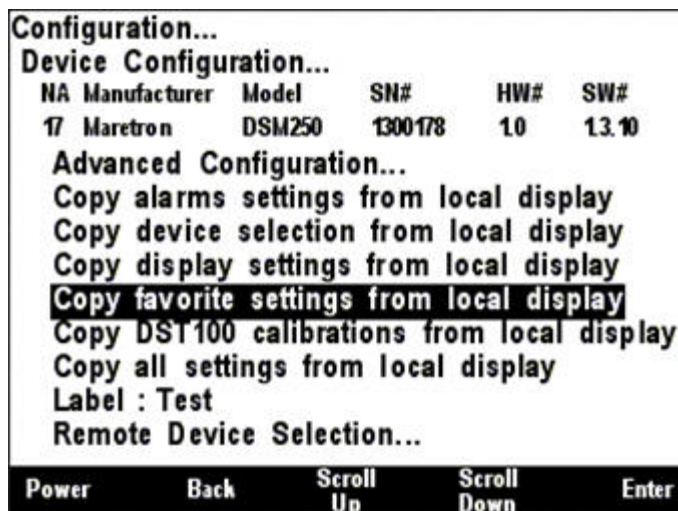
After you select this menu item and press **Enter**, the device selection settings from this DSM250 unit will be copied to the selected remote DSM250 unit.

### 6.6.4 Copy display settings from local display



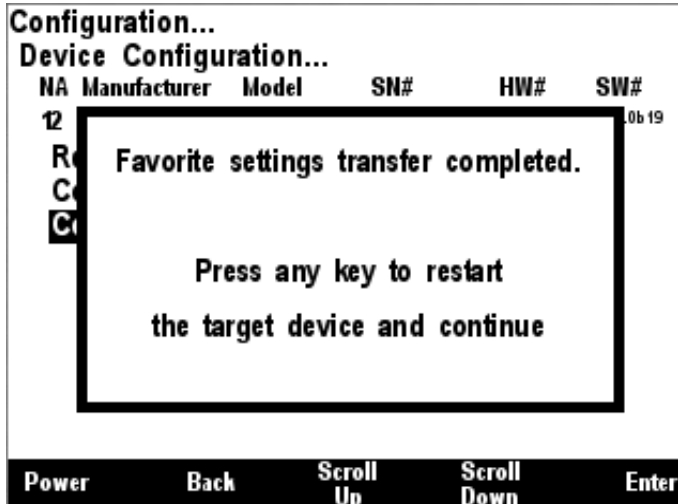
### 6.6.5 Copy favorite settings from local display

It is also possible to copy the favorite screen settings from one DSM250 to a remote DSM250 unit. This menu item can be seen selected in Figure 55 below.



**Figure 55 – DSM250 Copy favorite settings from local display**

By selecting this menu item and pressing Enter, all the favorite screen settings will be copied from the local DSM250 to the selected remote DSM250 unit. After copying favorite screen settings, it is necessary to restart the remote unit. A screen, which can be seen in Figure 56 below will appear indicating that favorite settings have been successfully transferred to the remote DSM250 and that the remote DSM250 must be restarted to complete the operation. Press Enter to restart the remote DSM250 unit, complete the favorite settings transfer operation, and return to the previous menu selection.

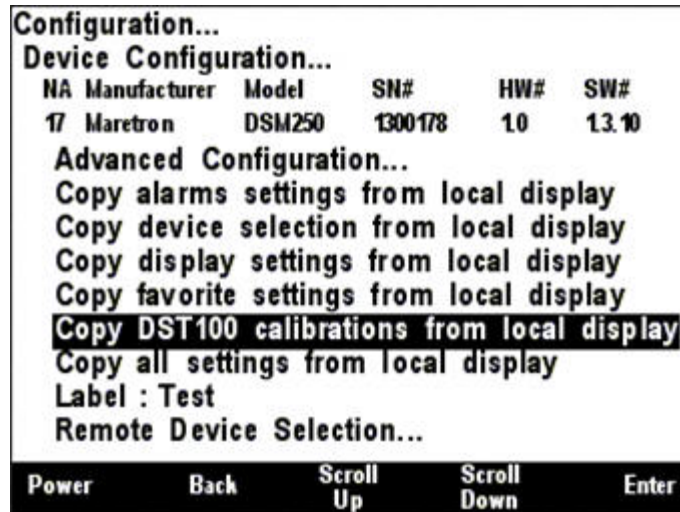


**Figure 56 – Favorite Settings Transfer Completion Screen**

## 6.6.6 Copy DST100 calibrations from local display

DST100 calibration data is not stored in the DST100 device. Rather each DSM250 needs to apply its own set of calibration parameters to the raw data received. This operation allows one DSM250 to copy its calibration table to a second DSC250.



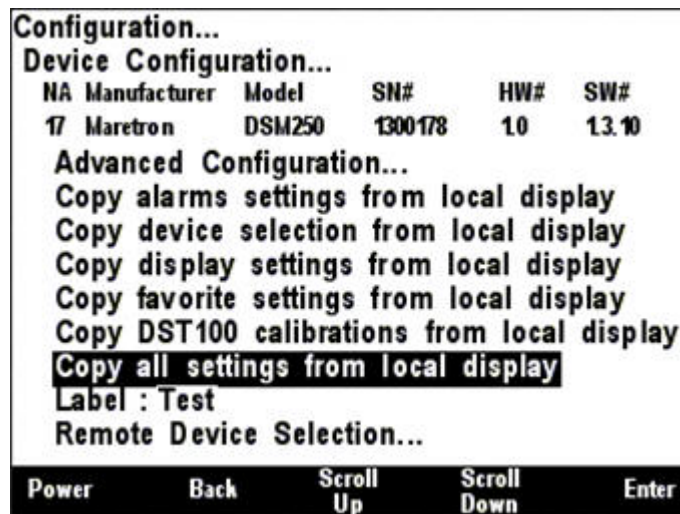


## 6.6.7 Copy all settings from local display

This is the single operation that makes it easy to have multiple DSM250 displays on a boat. Set one DSM250 up so that all its settings are correct, and quickly transfer all the alarms, device settings and display setting to another DSM250. Then go in and update the following information to customize the new device.

- Display Settings → Advanced Configuration → Installation Descriptions
- Display Settings → Label

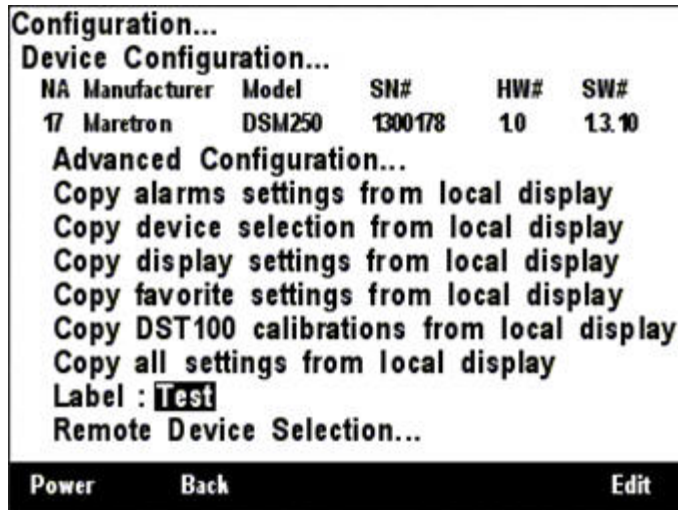
Also use this function to copy settings from an old DSM250 to a new DSM250 when replacing the device.



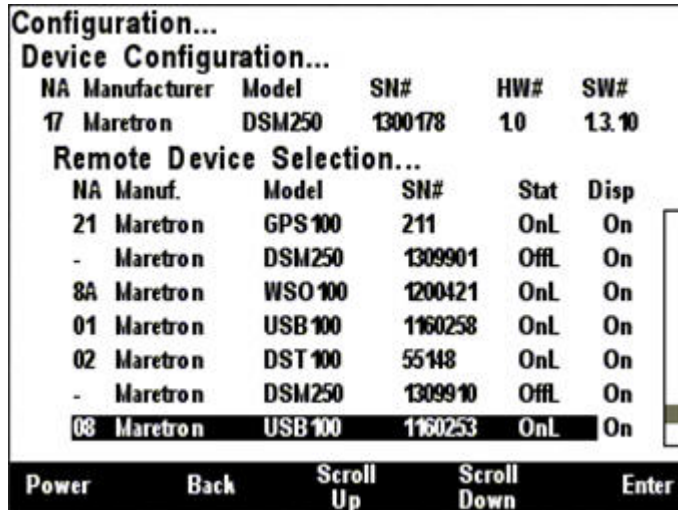
## 6.6.8 Label

The Label of the DSM250 is used by the Alert System to identify the source of an alert. Here, the label can be changed using the method described in section 3.3.4.

# DSM250 User's Manual



## 6.6.9 Remote Device Selection



## 6.7 Maretron DST100 Configuration

The DSM250 is capable of configuring Maretron's DST100 for several different parameters including trip log resetting, transducer depth offset, and speed calibration. This describes the configuration of the Maretron DST100 firmware version 1.0.1.

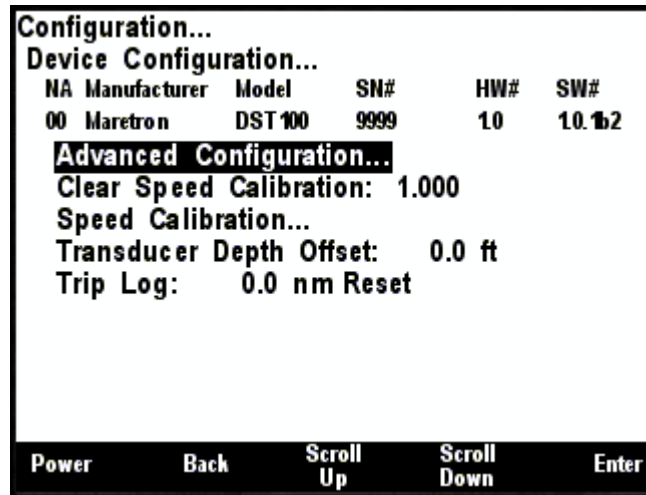


Figure 57 – DST100 Configuration Screen

### 6.7.1 Advanced Configuration

Advanced Configuration changes some complex parameters within the device, and should only be performed by an advanced user. Typically advanced configuration is only done at installation and should not need to be done while at sea.

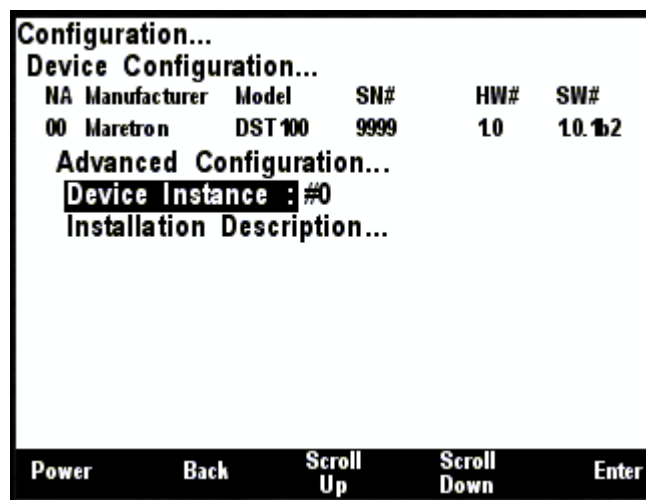


Figure 58 – DST100 Advanced Configuration Screen

#### 6.7.1.1 Device Instance

This entry allows you to program the NMEA 2000 device instance for the unit. You usually will not need to modify the default value of “0” unless you have multiple units on the network.

# DSM250 User's Manual

---

## 6.7.1.2 Installation Description

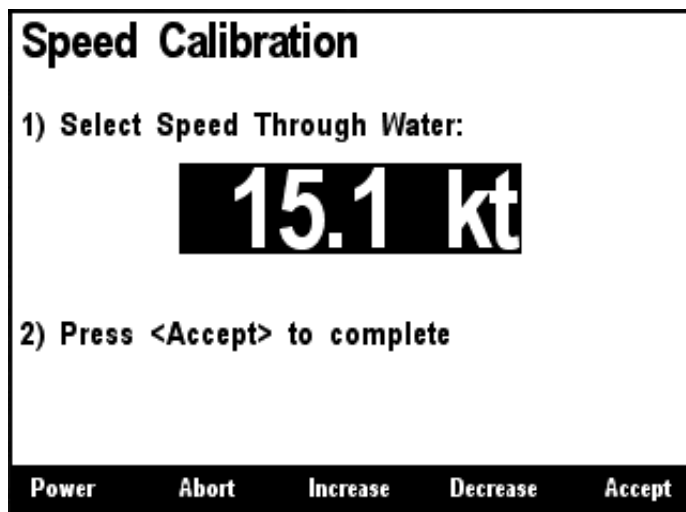
This entry allows you to modify the NMEA 2000 installation description text strings. You can enter any information you like here, such as the date the unit was installed, or the location in which it was installed, for later reference. Tools such as Maretron N2KAnalyzer allow you to view these values later. See section 3.3.4 for details on how to enter a textual value.

## 6.7.2 Clear Speed Calibration

The **Clear Speed Calibration** configuration parameter shows you the currently used correction factor. All STW readings for the particular DST100 (indicated by the SN#) are multiplied by this number to arrive at the displayed number. You can remove the correction factor by pressing the Enter key (↵) with the "Clear Speed Calibration:" menu item selected. And then choose "Clear" using Scroll Up (↑) or Scroll Down (↓) keys followed by the Enter key (↵). This changes the correction factor back to 1 such that all subsequent STW readings are no longer adjusted before displaying by the DSM250.

## 6.7.3 Speed Calibration

The DST100 speed through water (STW) initial accuracy is significantly affected by the location or placement of the DST100 within the hull. The DSM250 can correct for these inaccuracies using the speed calibration procedure. You calibrate the DSM250 for the DST100 STW by pressing the Enter key (↵) with the "Speed Calibration..." menu item selected which results in the screen shown in Figure 59.



*Figure 59 – Calibrating the DSM250 for DST100 Speed through Water*

The speed calibration screen shown above indicates the STW as measured by the DST100, which can be changed to the actual STW by following these steps. First, pick a speed where you are most concerned with the best accuracy. Next, bring the boat up to the desired speed using some other source, perhaps the GPS speed over ground (SOG). Remember that the SOG does not necessarily reflect the STW because of currents, and drift due to winds, so you should do this in an area where you are sure there are no currents and calm winds. Finally, use the Increase (↑) and Decrease (↓) keys to adjust the display value until it matches the known speed of the boat. Press the Accept (↵) key to accept the value when you are satisfied. If you do not wish to perform installation offset calibration at this time, press the Abort (⊗) key and the speed calibration will not be altered. The

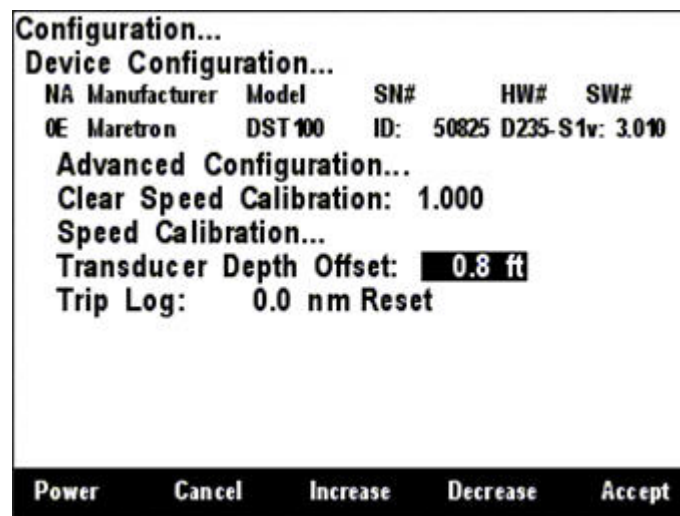
speed calibration process provides a method for the actual STW reading produced by the DST100 to be adjusted within the DSM250 (i.e., calibration data is not stored within the DST100).

**WARNING: Unlike resetting the trip log and setting the depth offset, which actually programs the DST100 so that all displays receive the same information, speed calibration must be performed at individual displays in order to show calibrated speed through water.**

## 6.7.4 Transducer Depth Offset

The DSM250 can set the transducer depth offset parameter in a DST100 depth/speed/temperature transducer. If you are interested in the actual water depth (as opposed to the depth beneath the keel), then you should program a positive value equal to the distance from the waterline to the depth of the DST100. The DSM250 will then add the measured depth of the water (as seen by the DST100) to the programmed offset value to produce the total water depth. If you are interested in the depth of water beneath the keel, then you should program a negative value equal to the distance between the DST100 and the bottom of the keel. The DSM will then subtract the programmed offset from the measured depth of the water (as seen by the DST100) showing you the depth of water beneath the keel.

You program the transducer depth offset by pressing the **Enter** key (↵) with the “Transducer Depth Offset:” menu item selected which results in the screen shown in Figure 60.



**Figure 60 – Setting the Transducer Depth Offset in a DST100**

With the offset value highlighted, you can change the offset by using the **Increase** and **Decrease** keys (↑ or ↓). Once you have selected the desired offset, push the **Enter** key (↵) to complete the transducer depth offset calibration. This procedure actually programs the offset value into the DST100 such that all displays subsequently receive the offset information. This means you don't have to program multiple displays each with the corresponding offset information as the information is stored at a single place (at the source).

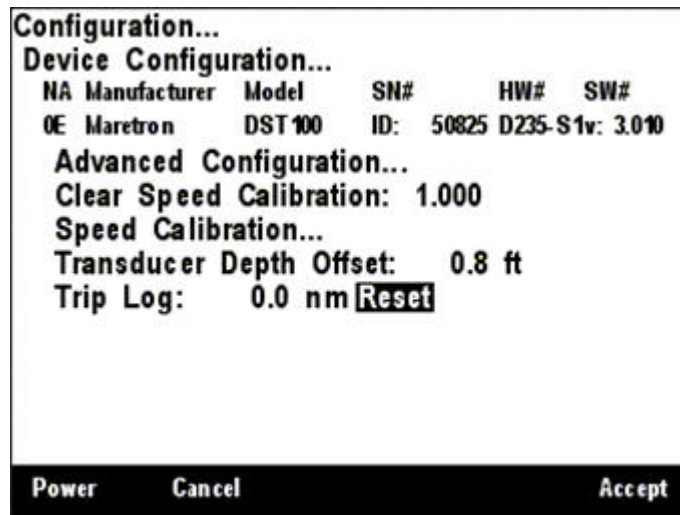
## 6.7.5 Trip Log

The DSM250 is capable of clearing the trip log counter within a DST100 depth/speed/temperature transducer. You zero the trip log by pressing the Enter key (↵) with the “Trip Log:” menu item selected which results in the screen shown Figure 61. Pressing the **Accept** (↵) key while the

# DSM250 User's Manual

---

“Reset” menu item is selected will complete the operation. Resetting the trip log zeroes the DST100's trip log such that all displays receive a zeroed value (i.e., you don't have to perform the operation from other DSM200/DSM250 locations).



*Figure 61 – Resetting the DST100 Trip Distance Log*



## 6.8 Maretron EMS100 Configuration

This describes the configuration of the Maretron EMS100 firmware version 1.2.

The EMS100 is configured to match the engine to which it is connected. The EMS100 Configuration changes some complex parameters within the device, and should only be performed by an advanced user. Typically advanced configuration is only done at installation and should not need to be done while at sea.

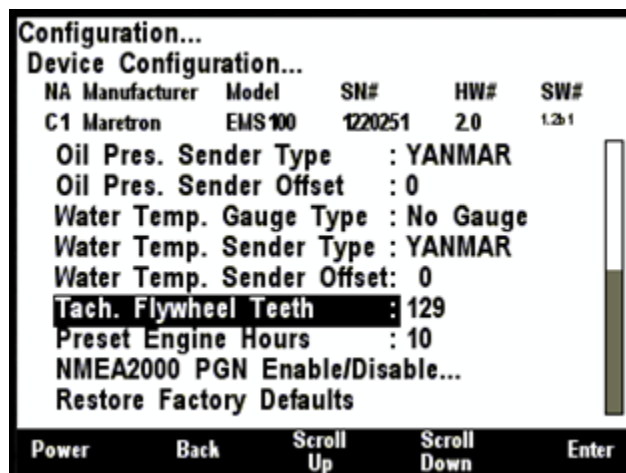
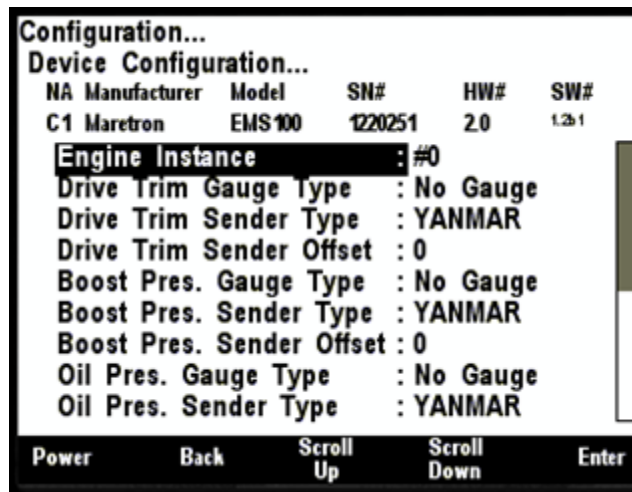


Figure 62 – EMS100 Configuration Screen

### 6.8.1 Engine Instance

This entry allows you to program the NMEA 2000 device instance for the unit. You usually will not need to modify the default value of “0” unless you have multiple engines on the network. By convention, the Port Engine is given an instance number of #0, and the Starboard Engine an instance number of #1. If there is a third center engine, it should be given an instance number of #2.

### 6.8.2 Boost Pressure Gauge Type

The EMS100 comes from the factory preprogrammed with the characteristics of boost pressure gauge types for supported engines. If the EMS100 is used with an analog boost pressure gauge, you must select the correct type of gauge for this setting in order for the data to be displayed correctly. Valid options are:

# DSM250 User's Manual

---

- **No Gauge** – select this option if there is no boost pressure gauge present.
- **YANMAR**

Select the required option using the **Scroll Up** and **Scroll Down** keys followed by the **Enter** key.

## 6.8.3 Boost Pressure Sender Type

The EMS100 comes from the factory preprogrammed with the characteristics of boost pressure senders for supported engines. If the engine to which you are connecting the EMS100 has a boost pressure sender, you must select the correct type of boost pressure sender for this setting in order for the data to be displayed correctly. Valid options are:

- **Disabled** – select this option if there is no boost pressure sender present.
- **YANMAR**

Select the required option using the **Scroll Up** and **Scroll Down** keys followed by the **Enter** key.

## 6.8.4 Boost Pressure Sender Offset

Often, the characteristics of individual boost pressure senders vary from their specified values. This setting allows you to apply an offset to the resistance value of the boost pressure sender in order to allow you to bring the digital value reported by the EMS100 into agreement with that displayed by the analog gauge.

## 6.8.5 Drive Trim Gauge Type

The EMS100 comes from the factory preprogrammed with the characteristics of drive trim gauge types for supported engines. If the EMS100 is used with an analog drive trim gauge, you must select the correct type of gauge for this setting in order for the data to be displayed correctly. Valid options are:

- **No Gauge** – select this option if there is no trim gauge present.
- **YANMAR**

Select the required option using the **Scroll Up** and **Scroll Down** keys followed by the **Enter** key.

## 6.8.6 Drive Trim Sender Type

The EMS100 comes from the factory preprogrammed with the characteristics of drive trim senders for supported engines. If the engine to which you are connecting the EMS100 has a drive trim sender, you must select the correct type of drive trim sender for this setting in order for the data to be displayed correctly. Valid options are:

- **Disabled** – select this option if there is no drive trim sender present.
- **YANMAR**

Select the required option using the **Scroll Up** and **Scroll Down** keys followed by the **Enter** key.



## 6.8.7 Drive Trim Sender Offset

Often, the characteristics of individual drive trim senders vary from their specified values. This setting allows you to apply an offset to the resistance value of the drive trim sender in order to allow you to bring the digital value reported by the EMS100 into agreement with that displayed by the analog gauge. Valid options are:

- **-100...100** –

Select the required option using the **Increase** and **Decrease** keys followed by the **Enter** key.

## 6.8.8 Oil Pressure Gauge Type

The EMS100 comes from the factory preprogrammed with the characteristics of oil pressure gauge types for supported engines. If the EMS100 is used with an analog oil pressure gauge, you must select the correct type of gauge for this setting in order for the data to be displayed correctly. Valid options are:

- **No Gauge** – select this option if there is no oil pressure gauge present.
- **YANMAR**
- **YANMAR / VDO**

Select the required option using the **Scroll Up** and **Scroll Down** keys followed by the **Enter** key.

## 6.8.9 Oil Pressure Sender Type

The EMS100 comes from the factory preprogrammed with the characteristics of oil pressure senders for supported engines. If the engine to which you are connecting the EMS100 has a oil pressure sender, you must select the correct type of oil pressure sender for this setting in order for the data to be displayed correctly. Valid options are:

- **Disabled** – select this option if there is no oil pressure sender present.
- **YANMAR**
- **YANMAR / VDO**

Select the required option using the **Scroll Up** and **Scroll Down** keys followed by the **Enter** key.

## 6.8.10 Oil Pressure Sender Offset

Often, the characteristics of individual oil pressure senders vary from their specified values. This setting allows you to apply an offset to the resistance value of the oil pressure sender in order to allow you to bring the digital value reported by the EMS100 into agreement with that displayed by the analog gauge. Valid options are:

- **-100...100** –

Select the required option using the **Increase** and **Decrease** keys followed by the **Enter** key.

## 6.8.11 Water Temperature Gauge Type

The EMS100 comes from the factory preprogrammed with the characteristics of water temperature gauge types for supported engines. If the EMS100 is used with an analog water temperature gauge,

# DSM250 User's Manual

---

you must select the correct type of gauge for this setting in order for the data to be displayed correctly. Valid options are:

- **No Gauge** – select this option if there is no water temperature gauge present.
- **YANMAR**
- **YANMAR / VDO**

Select the required option using the **Scroll Up** and **Scroll Down** keys followed by the **Enter** key.

## 6.8.12 Water Temperature Sender Type

The EMS100 comes from the factory preprogrammed with the characteristics of water temperature senders for supported engines. If the engine to which you are connecting the EMS100 has a water temperature sender, you must select the correct type of water temperature sender for this setting in order for the data to be displayed correctly. Valid options are:

- **Disabled** – select this option if there is no water temperature sender present.
- **YANMAR**
- **YANMAR / VDO**

Select the required option using the **Scroll Up** and **Scroll Down** keys followed by the **Enter** key.

## 6.8.13 Water Temperature Sender Offset

Often, the characteristics of individual water temperature senders vary from their specified values. This setting allows you to apply an offset to the resistance value of the water temperature sender in order to allow you to bring the digital value reported by the EMS100 into agreement with that displayed by the analog gauge. Valid options are:

- **-100...100** –

Select the required option using the **Increase** and **Decrease** keys followed by the **Enter** key.

## 6.8.14 Preset Engine Hours

The EMS100 reports engine hours based on how long the EMS100 has been powered from the engine. The EMS100 comes from the factory preprogrammed with an engine hours reading of 0 hours. If you are installing the EMS100 on an engine that has been in service, or if you have overhauled an engine, you can use this setting to preset the engine hours reading to the desired value. Valid options are:

- **0...99999** – hours

Select the required option using the **Increase** and **Decrease** keys followed by the **Enter** key.

## 6.8.15 Tachometer Flywheel Teeth

The EMS100 needs to know the number of flywheel teeth on the engine (or the number of alternator pulses per revolution) in order to correctly calculate engine RPM. Use this setting to program the EMS100

with the number of flywheel teeth or alternator pulses per revolution for the engine to which the EMS100 is connected. Valid options are:

- **0...400** – pulses per revolution

Select the required option using the **Increase** and **Decrease** keys followed by the **Enter** key.

## 6.9 Maretron GPS100 Configuration

This describes the configuration of the Maretron GPS100 firmware version 1.0.6. *Some versions of the GPS100 have a different set of firmware that is currently at version 1.6.14. The configuration of these devices is identical to version 2.0.1 shown here.* The GPS100 has several different programmable parameters that are configurable by the DSM250 display. Normally, it is not necessary to configure the GPS100 although there may be some circumstances where configuration is desirable. The following sections describe the different configuration modes including the "Restore Factory Defaults" configuration, which allows you to return the GPS100 to the factory settings.

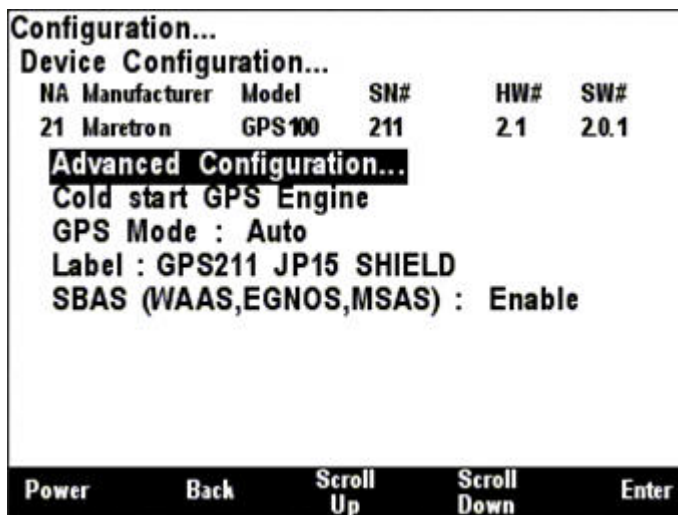


Figure 63 – GPS100 Configuration Screen

### 6.9.1 Advanced Configuration

Advanced Configuration changes some complex parameters within the device, and should only be performed by an advanced user. Typically advanced configuration is only done at installation and should not need to be done while at sea. The Advanced Configuration Screen is shown below.

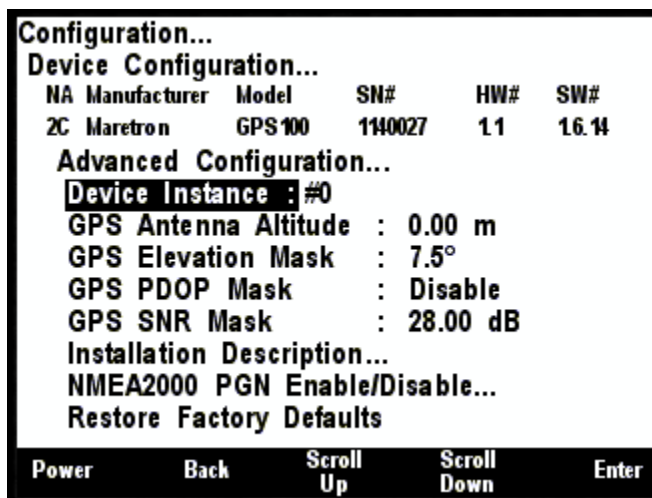


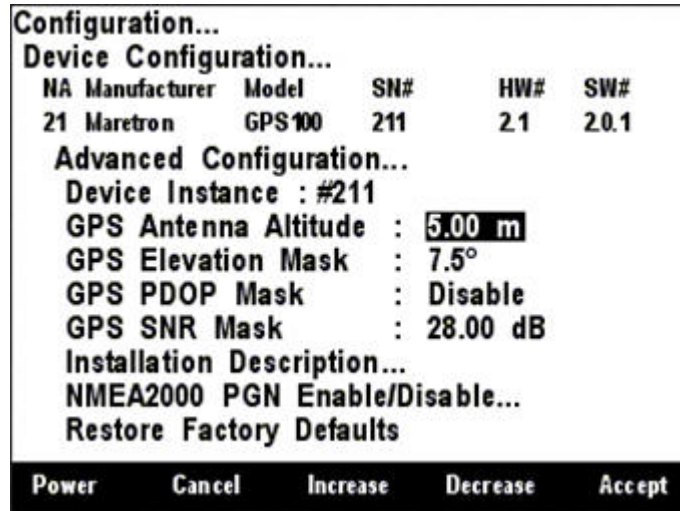
Figure 64 – GPS100 Advanced Configuration Screen

## 6.9.1.1 Device Instance

The Device Instance will be used to identify the GPS100 device on the network. Unless there are multiple GPSs on the network, this should be left at zero.

## 6.9.1.2 GPS Antenna Altitude

The DSM250 is capable of setting the antenna altitude on a Maretron GPS100. You can choose this setting by pressing the Enter key (↵) with the “Antenna Altitude:” menu item selected which causes the screen shown in Figure 65 to be displayed.

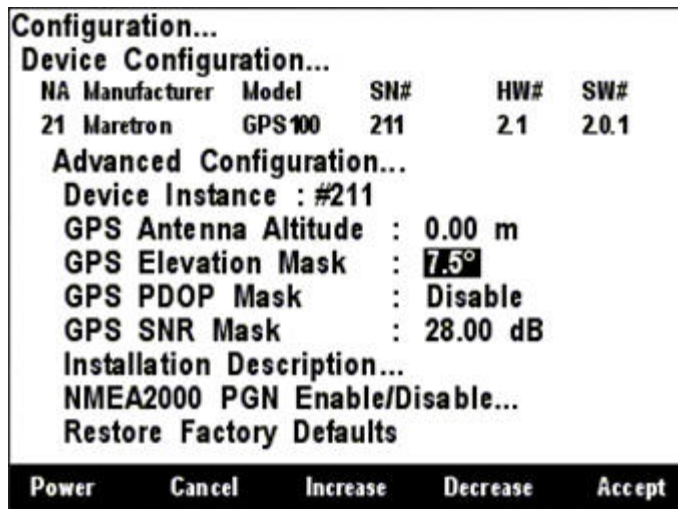


*Figure 65 – Configuring Antenna Altitude on a GPS100*

The allowable values for the Antenna Altitude are between -100m and 100m. This number represents the altitude of the GPS100, and is used to improve the quality of the position fix if only a two-dimensional fix is obtainable. If a three-dimensional position fix is obtainable, this value is not used.

## 6.9.1.3 Elevation Mask

The DSM250 is capable of setting the Elevation Mask on a Maretron GPS100. You can choose this setting by pressing the Enter key (↵) with the “Elevation Mask:” menu item selected which causes the screen shown in Figure 66 to be displayed.

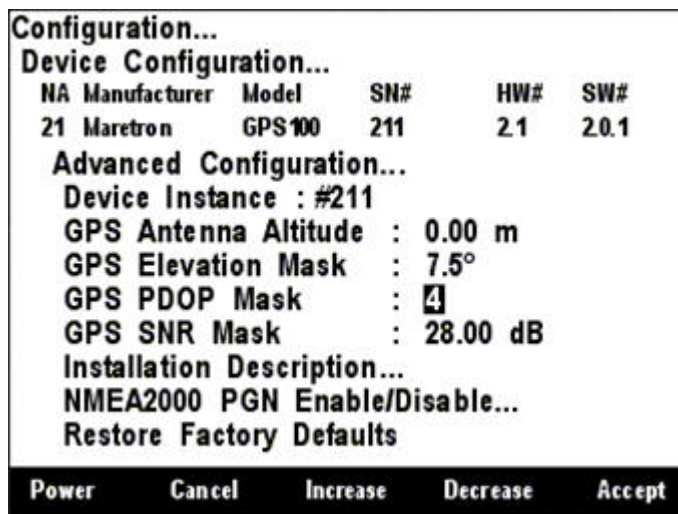


**Figure 66 – Configuring Satellite Elevation Mask on a GPS100**

The allowable values for Elevation Mask are between  $-90^{\circ}$  and  $90^{\circ}$ . This number represents the elevation of a satellite above the horizon. Satellites with  $0^{\circ}$  elevation are at the horizon, while satellites with  $90^{\circ}$  elevation are directly overhead. The GPS will exclude satellites with an elevation lower than the value of this parameter from the position solution.

#### 6.9.1.4 PDOP Mask

The DSM250 is capable of setting the PDOP Mask on a Maretron GPS100. You can choose this setting by pressing the Enter key (↵) with the "PDOP Mask:" menu item selected which causes the screen shown in Figure 67 to be displayed.



**Figure 67 – Configuring PDOP Mask on a GPS100**

The allowable values for PDOP Mask are between 1 and 20. This number represents the Position Dilution of Precision, which indicates the accuracy of the computed position and is a function of the positions of the received satellites. If the PDOP of a given position solution is above the value of this parameter, then the GPS100 will report that no fix is obtained. Disabling the PDOP Mask by setting

the value to “-“) will cause the GPS100 to report any position fixes obtained, regardless of the accuracy of the fix.

### 6.9.1.5 SNR Mask

The DSM250 is capable of setting the SNR (Signal to Noise Ratio) Mask on a GPS100. You choose this setting by pressing the Enter key (↵) with the **GPS SNR Mask** menu item selected which results in the screen shown in Figure 68.

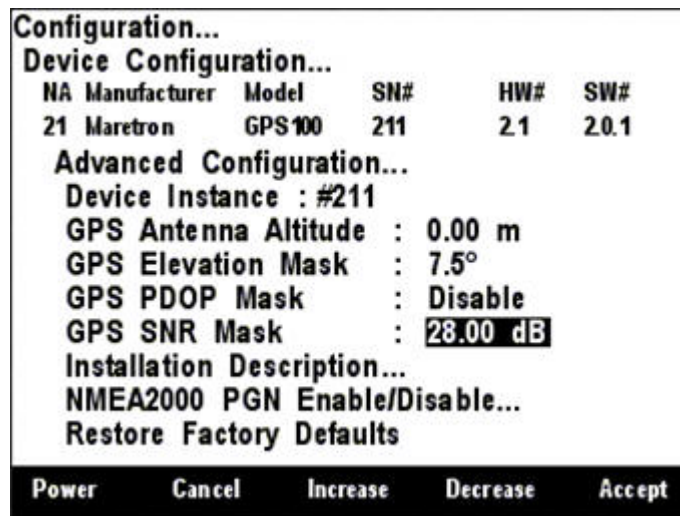


Figure 68 – Configuring SNR Mask on a GPS100

The allowable values for the SNR Mask are between 1 dB and 60 dB. This number represents the signal to noise ratio of a satellite’s signal as received by the GPS100. Higher numbers indicate a better quality signal. The GPS will exclude satellites with signal to noise ratios lower than the value of this parameter from the position solution.

### 6.9.1.6 Installation Description

This entry allows you to modify the NMEA 2000 installation description text strings. You can enter any information you like here, such as the date the unit was installed, or the location in which it was installed, for later reference. Tools such as Maretron N2KAnalyzer allow you to view these values later. See section 3.3.4 for details on how to enter a textual value.

### 6.9.1.7 NMEA 2000® PGN Enable/Disable

The GPS100 transmits several different messages, which can be turned on or turned off by the DSM250 display. Pressing the Enter key (↵) with “NMEA2000 PGN Enable/Disable...” menu item selected causes the DSM250 to display the screen shown in Figure 69.



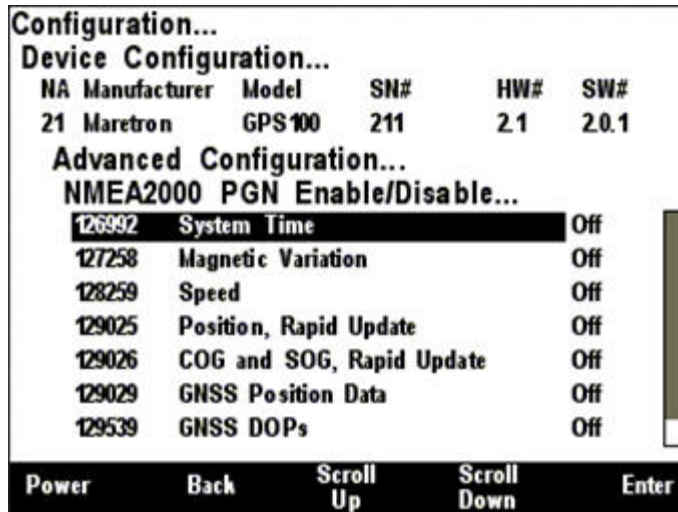


Figure 69 – GPS100 NMEA 2000® PGN Enable/Disable Screen

You can enable or disable specific transmissions by scrolling (↑ or ↓) through the different transmitted messages and pressing the Enter key (↵) on the message to be configured. Select whether you want the message to be transmitted (“On”) or disabled (“Off”) using the Scroll Up (↑) or Scroll Down (↓) keys followed by the Enter key (↵).

### 6.9.1.8 Restore Factory Defaults

The DSM250 is capable of restoring all programmable settings on a Maretron GPS100 to the factory default condition. You can choose this setting by pressing the Enter key (↵) with the “Restore Factory Defaults” menu item selected which causes the screen shown in Figure 70 to be displayed. This will cause the GPS100 to set all programmable settings to the factory default condition.

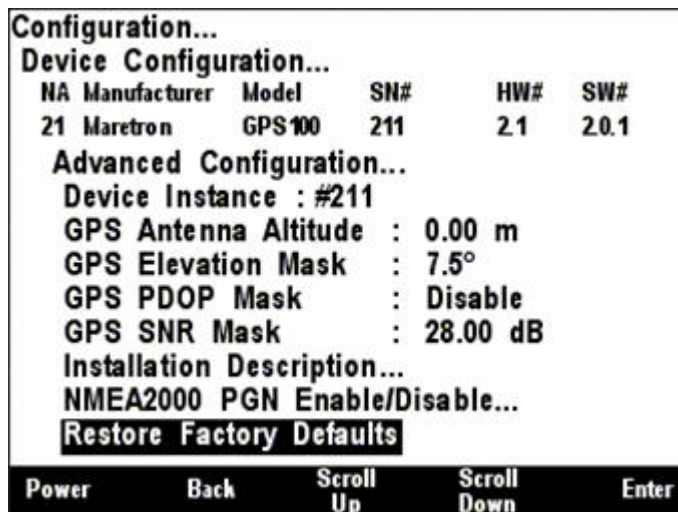


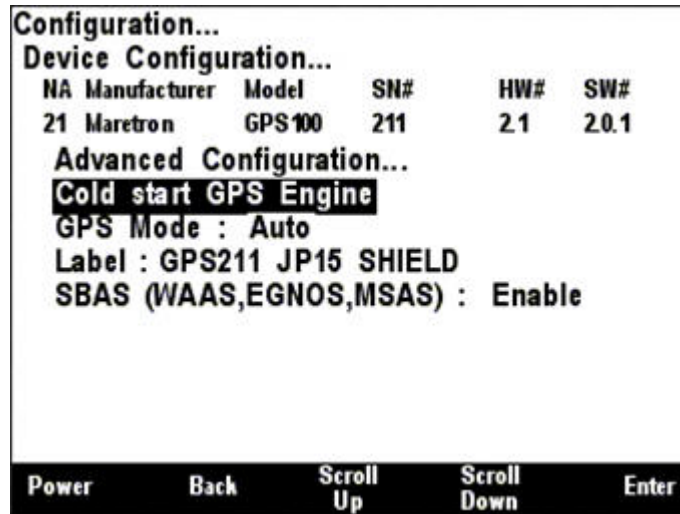
Figure 70 – Restoring Factory Defaults on the GPS100

### 6.9.2 Cold Start GPS

The DSM250 is capable of restarting the GPS algorithm on a Maretron GPS100. You can choose this setting by pressing the Enter key (↵) with the “Cold start GPS Engine” menu item selected which



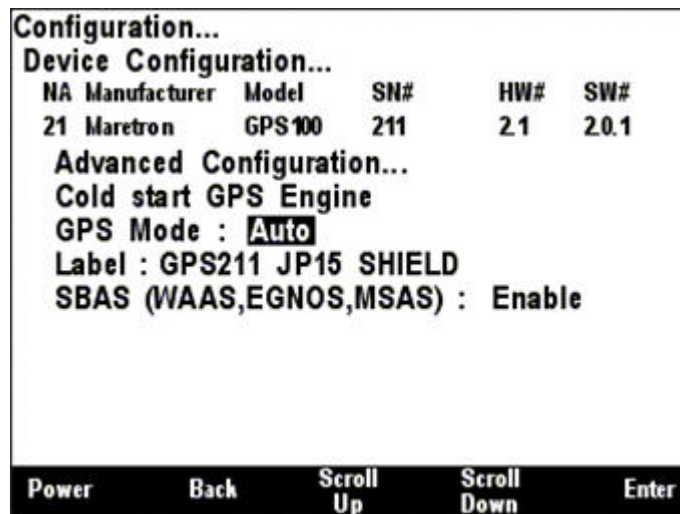
causes the screen shown in Figure 71 to be displayed. This will cause the GPS100 to discard all position and satellite data and compute a position fix.



**Figure 71 – Performing a Cold Start of the GPS100**

### 6.9.3 GPS Mode Setting

The DSM250 is capable of setting the minimum operating mode on a Maretron GPS100. You can choose this setting by pressing the Enter key (↵) with the “GPS Mode:” menu item selected which causes the screen shown in Figure 72 to be displayed.



**Figure 72 – Configuring GPS Operating Mode on a GPS100**

The allowable options for GPS Mode are “1D” which allows the GPS to report data when only a one-dimensional fix (time only) or better is obtained; “2D”, which allows the GPS to report data only when a two-dimensional fix or better is obtained; “3D”, which allows the GPS to report data only when a three-dimensional fix or better is obtained, or “Auto” (default), which allows the GPS to report any available data, regardless of the quality of the fix.

# DSM250 User's Manual

---

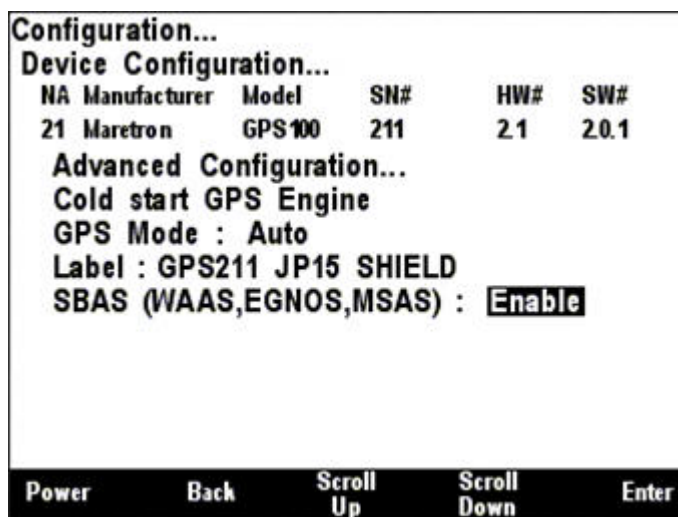
## 6.9.4 Device Label

A label may be assigned to the GPS100 as an aid to identifying the device over the network. Typically this would describe the location of the GPS on the vessel.

See section 3.3.4 for details on how to enter a textual value.

## 6.9.5 SBAS (WAAS) Enable/Disable

The DSM250 is capable of enabling or disabling the SBAS (WAAS) function on a Maretron GPS Antenna/Receiver (GPS100). You can change this setting by pressing the Enter key (⏎) with the "SBAS: WAAS,EGNOS,MSAS:" menu item selected which causes the screen shown in Figure 73 to be displayed.



**Figure 73 – Configuring SBAS on a GPS100**

The allowable option for SBAS configuration are either "Disable" which causes the GPS100 not to use SBAS satellites, or "Enable" which causes the GPS100 to use SBAS satellites for developing a position fix.

## 6.10 Maretron J2K100 Configuration

This describes the configuration of the Maretron J2K100 firmware version 1.0.7. The DSM250 is capable of configuring settings for the J1939 to NMEA 2000® Gateway (J2K100). A screenshot of the J2K100 configuration menu is shown in Figure 74 below.

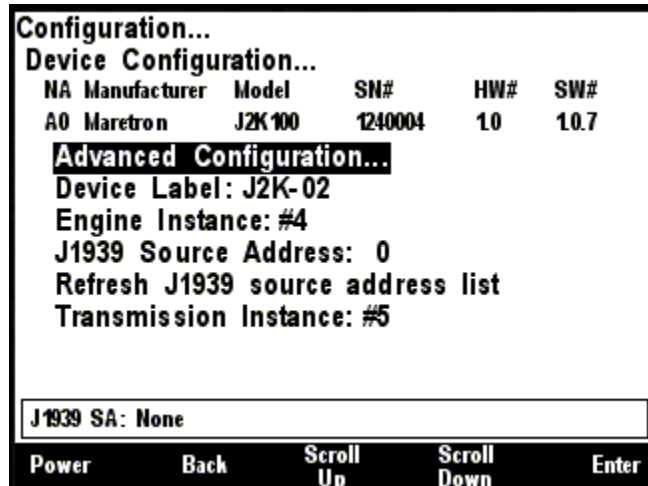


Figure 74 – J2K100 Configuration Screen

### 6.10.1 Advanced Configuration

Advanced Configuration changes some complex parameters within the device, and should only be performed by an advanced user. Typically advanced configuration is only done at installation and should not need to be done while at sea.

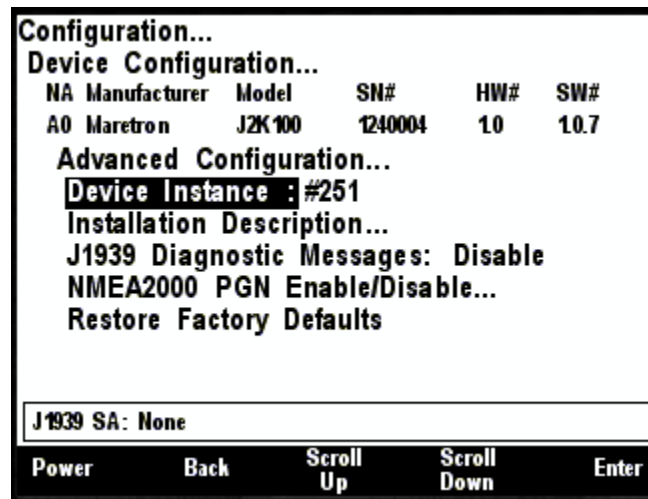


Figure 75 – J2K100 Advanced Configuration Screen

#### 6.10.1.1 Device Instance

The Device Instance will be used to identify the J2K100 module on the network. If a GenSet is connected to the J1939 network, and the AC parameters passed through the J2K100 interface, the GenSet will also be identified using Device Instance number.

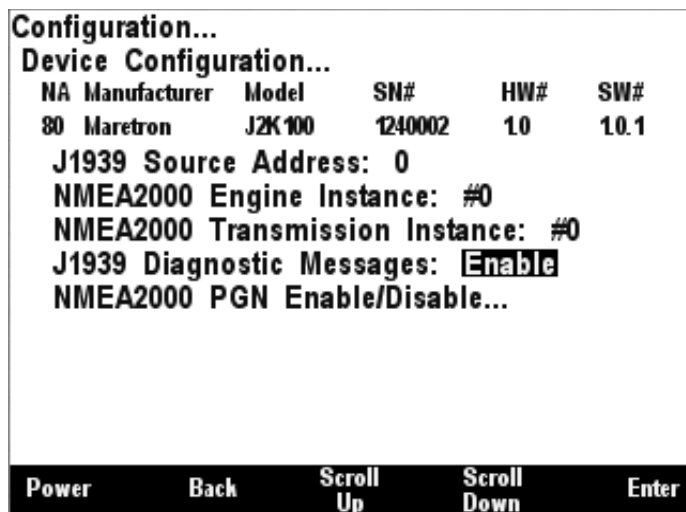
# DSM250 User's Manual

## 6.10.1.2 Installation Description

This entry allows you to modify the NMEA 2000 installation description text strings. You can enter any information you like here, such as the date the unit was installed, or the location in which it was installed, for later reference. Tools such as Maretron N2KAnalyzer allow you to view these values later. See section 3.3.4 for details on how to enter a textual value.

## 6.10.1.3 J1939 Diagnostic Messages

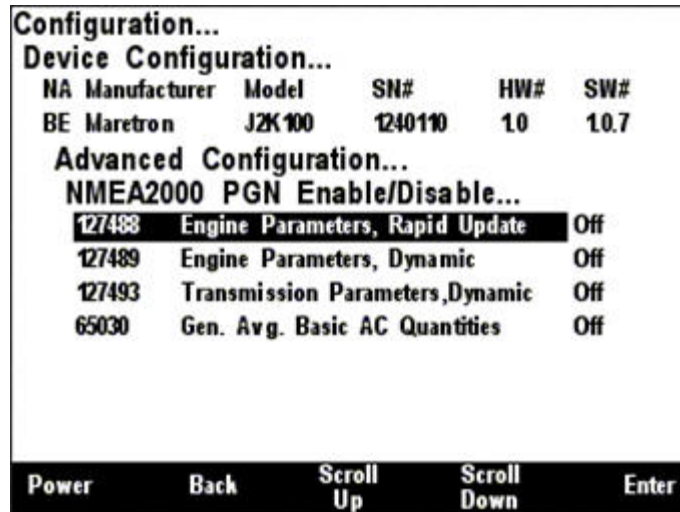
The J2K100 can optionally pass through J1939 diagnostic messages, used to indicate fault conditions on engines and transmissions, from the J1939 interface to the NMEA2000<sup>®</sup> network so that NMEA 2000<sup>®</sup> connected displays can interpret these diagnostic codes. To change the transmission status of the J1939 diagnostic messages, use the Scroll Up (↑) or Scroll Down (↓) keys to move the highlighted cursor to the “J1939 Diagnostic Messages:” menu item. Then, press the Enter key (↵) to move the highlight to the value field, which displays either Enable or Disable. Use the Scroll Up (↑) or Scroll Down (↓) keys to change the value to the desired value, and then press the Enter key (↵) to accept the new value and store it within the J2K100.



*Figure 76 – J1939 Diagnostic Messages Configuration*

## 6.10.1.4 NMEA2000 PGN Enable/Disable

The J2K100 interface transmits several different messages, which can be turned on or turned off by the DSM250 display. Pressing the **Enter** key (↵) with “NMEA2000 PGN Enable/Disable...” menu item selected causes the DSM250 to display the following screen.



**Figure 77 – J2K100 NMEA 2000® PGN Enable/Disable Screen**

You can enable or disable specific transmissions by scrolling (↑ or ↓) through the different transmitted messages and pressing the Enter key (↵) on the message to be configured. Select whether you want the message to be transmitted (“On”) or disabled (“Off”) using the Scroll Up (↑) or Scroll Down (↓) keys followed by the Enter key (↵).

### 6.10.1.5 Restore Factory Defaults

This option restores all settings on the device to their factory default state.

### 6.10.2 Device Label

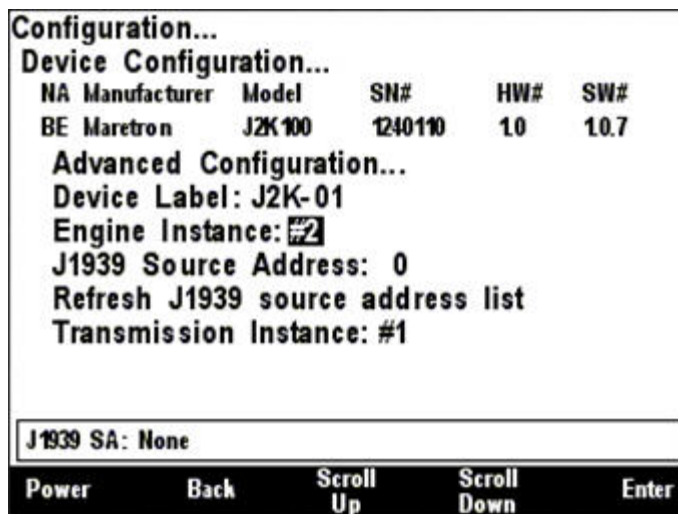
A label may be assigned to the J2K100 as an aid to identifying the device over the network.

See section 3.3.4 for details on how to enter a textual value.

### 6.10.3 Engine Instance

This entry allows the engine to be mapped to an NMEA2000 instance number. Each engine on an NMEA 2000® network must have a unique instance identifier, to allow display devices to distinguish it from other engines on the network. The “NMEA2000 Engine Instance:” menu item allows you to configure the engine instance identifier which will be sent over the NMEA 2000® network along with engine-related NMEA 2000® messages. In order to configure this parameters, use the Scroll Up (↑) or Scroll Down (↓) keys to move the highlighted cursor to the “NMEA2000 Engine Instance:” menu item. Then, press the Enter key (↵) to move the highlight to the numeric value on the right, as shown in below.

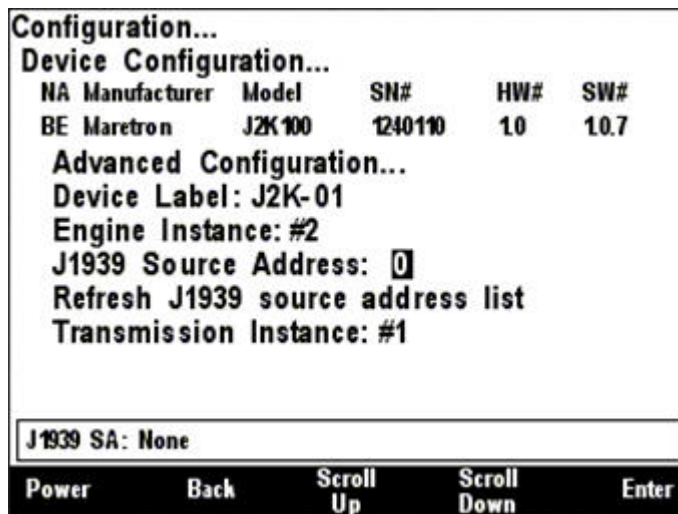
Because only one such mapping can take place, each engine on the J1939 network must have its own J2K100 Gateway. The J1939 Source Address (see section 6.10.4) identifies the engine on the J1939 network, the Engine Instance identifies the engine to the NMEA2000 network.



Use the **Scroll Up** and **Scroll Down** keys to change the value to the desired value you wish to use as the engine instance identifier, and then press the **Enter** key to accept the value and store it within the J2K100.

## 6.10.4 J1939 Source Address Configuration

A J1939 engine/genset and transmission has its own source address on the J1939 network, which is different from NMEA 2000® addresses. The J2K100 is capable of serving as a gateway between a single J1939 engine/genset or a single transmission and the NMEA 2000® network. This setting identifies the J1939 source address of the engine/genset and a transmission for which the J2K100 will serve as a gateway.



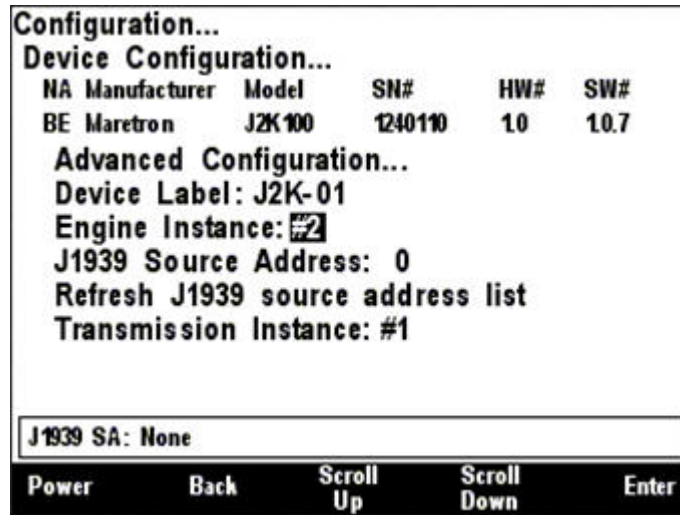
*Figure 78 – J1939 Source Address Configuration*

To set the J1939 source address, use the **Scroll Up** and **Scroll Down** keys to move the highlighted cursor to the “J1939 Source Address:” menu item. Press the **Enter** key to move the cursor over to the source address value on the right, as shown in Figure 78 above. Then, use the **Scroll Up** and **Scroll Down** keys to change the J1939 Source Address value until it matches the J1939 source address of the engine/genset or transmissions for which you desire this J2K100 to translate data onto the NMEA 2000® network.



## 6.10.5 Refresh J1939 source address list

The configuration screen for the J2K100 will examine the bus to determine to which devices it can connect. This is presented in a list at the bottom of the screen. To update the list after adding a device, highlight this entry, and press the **Enter** button.



## 6.10.6 Transmission Instance

This entry allows a transmission to be mapped to an NMEA2000 instance number. Each transmission on an NMEA 2000® network must have a unique instance identifier, to allow display devices to distinguish it from other transmissions on the network. The “NMEA2000 Transmission Instance:” menu item allows you to configure the transmission instance identifier which will be sent over the NMEA 2000® network along with transmission-related NMEA 2000® messages. In order to configure this parameters, use the Scroll Up (↑) or Scroll Down (↓) keys to move the highlighted cursor to the “NMEA2000 Transmission Instance:” menu item. Then, press the Enter key (↵) to move the highlight to the numeric value on the right, as shown in Figure 79 below. Because only one such mapping can take place, each Transmission and each Engine on the J1939 network must have its own J2K100 Gateway. The J1939 Source Address (see section 6.10.4) identifies the transmission on the J1939 network, the Transmission Instance identifies the transmission to the NMEA2000 network.

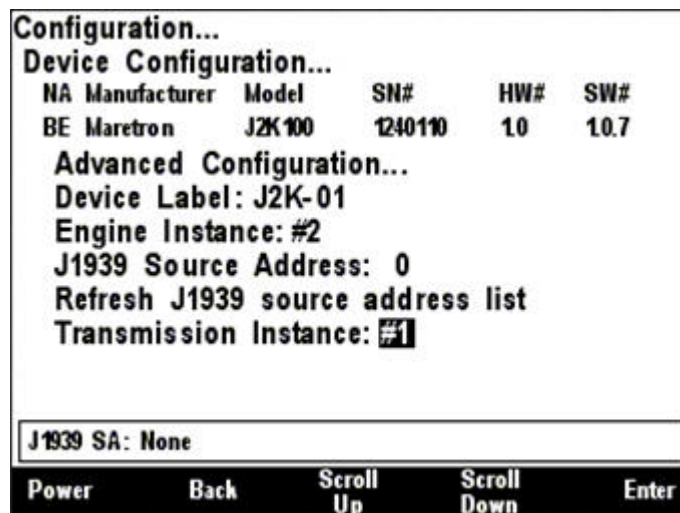


Figure 79 – NMEA2000 Transmission Instance Configuration

# DSM250 User's Manual

---

Use the Scroll Up (⬆) or Scroll Down (⬇) keys to change the value to the desired value you wish to use as the engine instance identifier, and then press the Enter key (↵) to accept the value and store it within the J2K100.



## 6.11 Maretron RAA100 Configuration

This describes the configuration of the Maretron RAA100 firmware version 1.4.9.

Maretron RAA100 rudder angle adapters on the network may be configured using the DSM250. The RAA100 configuration menu is shown in Figure 80 below.

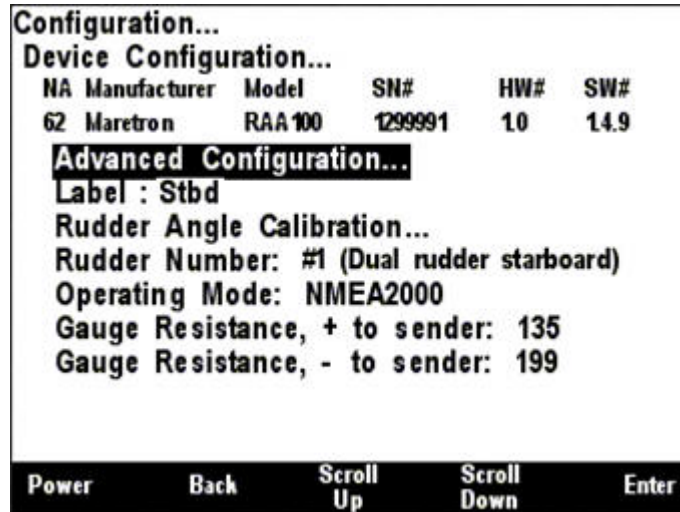
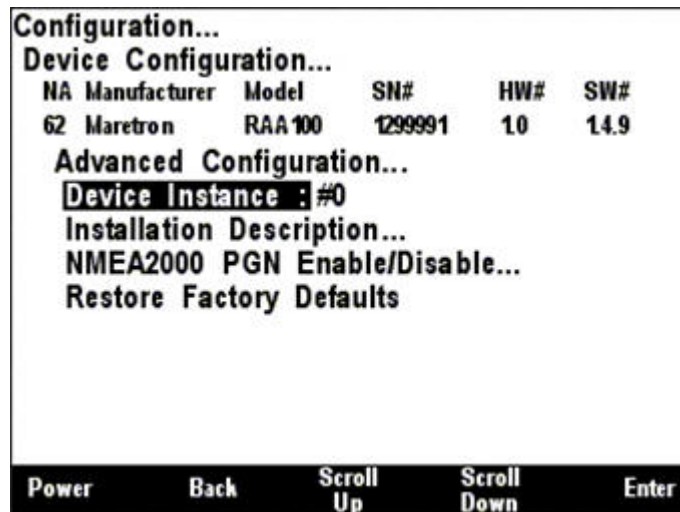


Figure 80 – RAA100 Configuration Screen

### 6.11.1 Advanced Configuration

Advanced Configuration changes some complex parameters within the device, and should only be performed by an advanced user. Typically advanced configuration is only done at installation and should not need to be done while at sea.



#### 6.11.1.1 Device Instance

This entry allows you to program the NMEA 2000 device instance for the unit. You usually will not need to modify the default value of "0" unless you have multiple units on the network.

# DSM250 User's Manual

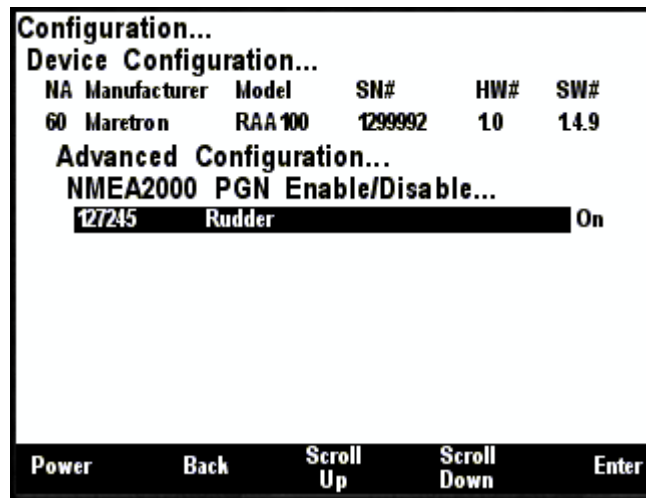
---

## 6.11.1.2 Installation Description

This entry allows you to modify the NMEA 2000 installation description text strings. You can enter any information you like here, such as the date the unit was installed, or the location in which it was installed, for later reference. Tools such as Maretron N2KAnalyzer allow you to view these values later. See section 3.3.4 for details on how to enter a textual value.

## 6.11.1.3 NMEA2000 PGN Enable/Disable

The RAA100 Rudder Angle Adapter transmits the NMEA2000 PGN #127245 which can be turned on or turned off by the DSM250 display. Pressing the **Enter** key with “NMEA2000 PGN Enable/Disable...” menu item selected causes the DSM250 to display the following screen.



*Figure 81 – RAA100 NMEA 2000® PGN Enable/Disable Screen*

You can enable or disable the transmission of the Rudder message by pressing the **Enter** key on the message to be configured. Options are:

- **Disable** – The status message will not be transmitted
- **Default** – The status message will be transmitted at its default NMEA2000 rate.

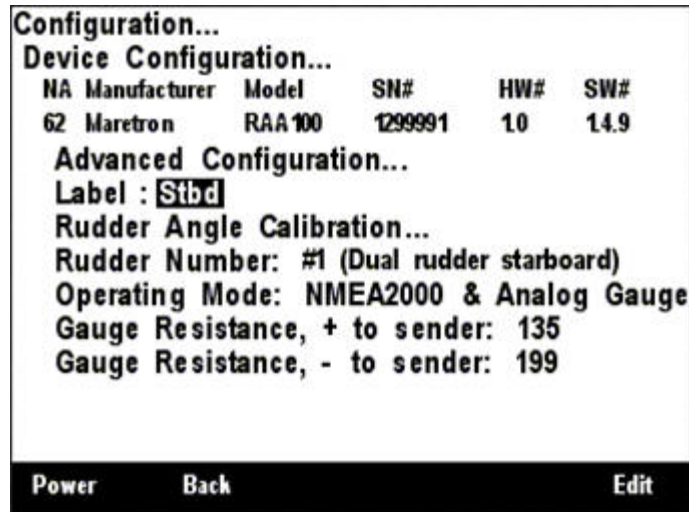
Select the required option using the **Scroll Up** and **Scroll Down** keys followed by the **Enter** key.

## 6.11.1.4 Restore Factory Defaults

This option restores all settings on the device to their factory default state.

## 6.11.2 Label

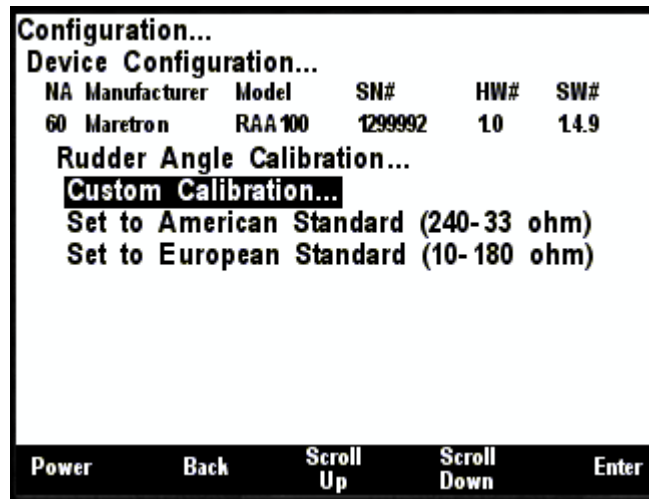
A label may be assigned to the RAA100 as an aid to identifying the device over the network. Typically this label will describe the rudder to which the RAA100 is connected (e.g. Port Rudder).



See section 3.3.4 for details on how to enter a textual value.

### 6.11.3 Rudder Angle Calibration

In order for the RAA100 to indicate an accurate rudder angle, it must know how the resistance of the resistive rudder angle sender corresponds to the rudder angle. The following screen will be displayed:



**Figure 82 – Rudder Angle Calibration Options**

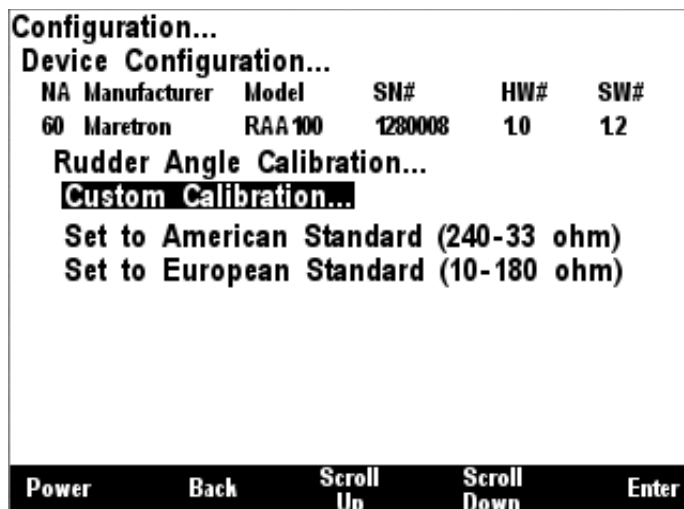
There are three methods of calibrating the rudder angle sender:

#### 6.11.3.1 Custom Calibration

The Custom Calibration setting will provide the most accurate rudder angle readings under any circumstances, but it requires that you go through a process in which you set the rudder to full port, then center, and then full starboard, each time indicating the angle of the rudder to the DSM250. The RAA100 will measure the sender resistance at each point and create a custom calibration map which relates the resistance of the sender with the rudder angle. Custom calibration is necessary for non-standard values of resistances for rudder angle senders and for rudders with maximum port and starboard angles of anything other than 45°.

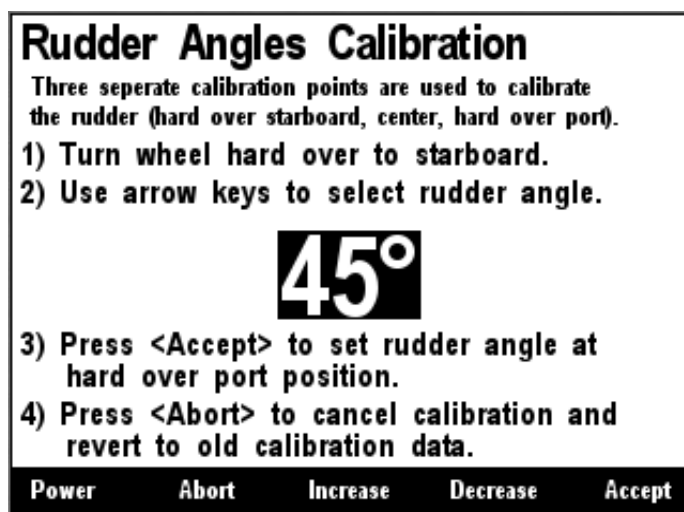
# DSM250 User's Manual

To perform custom calibration of the rudder angle sender, use the Scroll Up (↑) or Scroll Down (↓) keys to move the highlighted cursor over the “Custom Calibration...” menu item. Then, press the Enter key (↵) to confirm your selection and begin the calibration process. Figure 83 shows the DSM250 with the Custom Rudder Calibration menu item highlighted.



**Figure 83 – Custom Rudder Angle Calibration**

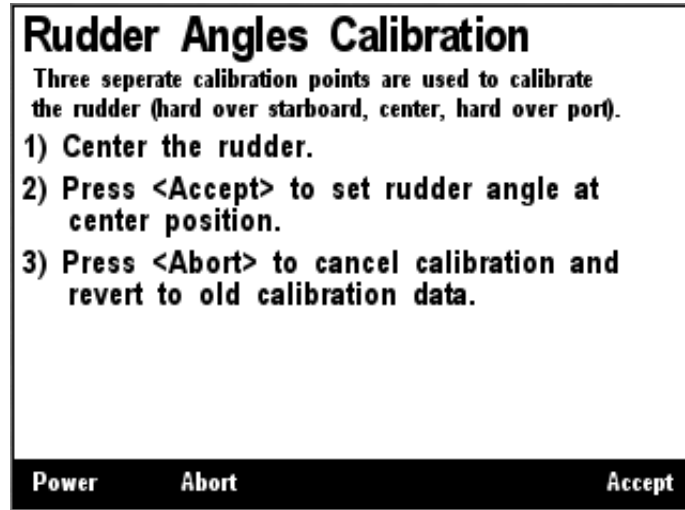
The first step in the custom rudder angle sender calibration process is to turn the wheel hard over to starboard, and to measure the angle of the rudder (angle from center) with a protractor or other instrument. Use the Increase and Decrease keys until the highlighted rudder angle value is at the measured value, and then press Enter to accept the value and store it within the RAA100. Figure 84 shows a screenshot of the starboard rudder calibration screen. You may also press the Abort Key (⊗) to end the calibration process.



**Figure 84 – Starboard Rudder Angle Calibration**

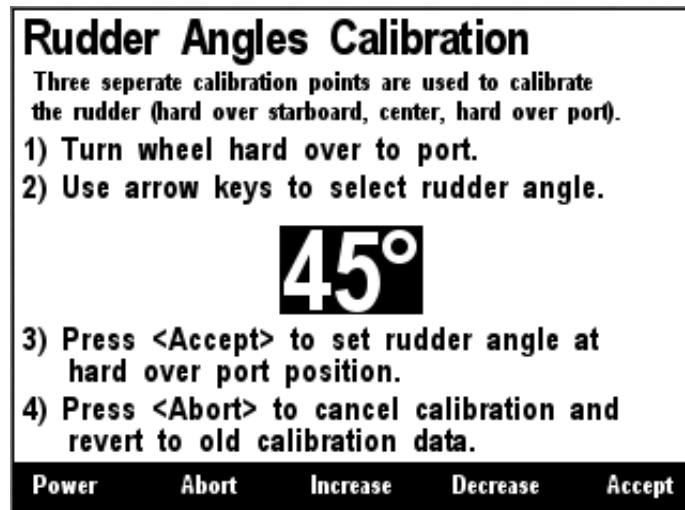
The second step in the custom rudder angle sender calibration process is to turn the wheel so that the rudder is centered as much as possible. Next, press Enter to accept the value and store it within

the RAA100. Figure 85 shows a screenshot of the center rudder calibration screen. You may also press the Abort Key (⊗) to end the calibration process.



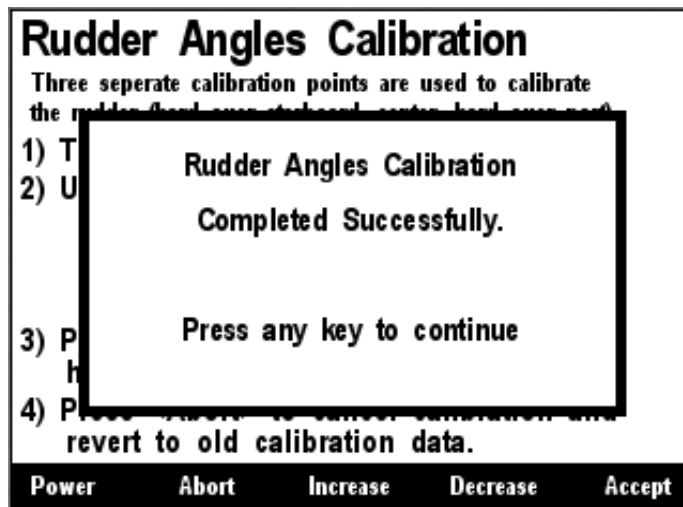
*Figure 85 – Center Rudder Angle Calibration*

The third step in the custom rudder angle sender calibration process is to turn the wheel hard over to port, and to measure the angle of the rudder (angle from center) with a protractor or other instrument. Use the Increase and Decrease keys until the highlighted rudder angle value is at the measured value, and then press Enter to accept the value and store it within the RAA100. Figure 84 shows a screenshot of the starboard rudder calibration screen. You may also press the Abort Key (⊗) to end the calibration process.



*Figure 86 – Port Rudder Angle Calibration*

Once you have accepted the port rudder angle value, a confirmation screen appears indicating that the rudder angle calibration has been successfully completed. Figure 87 below shows a screenshot of this confirmation screen.



*Figure 87 – Custom Rudder Calibration Confirmation Screen*

### 6.11.3.2 Set to American Standard (240-33 ohm)

Use the option for rudders using a rudder angle sender with the standard American resistance range (240 ohms at full port 45°, 33 ohms at full starboard 45°).

### 6.11.3.3 Set to European Standard (0-180 ohm)

Use this option for rudders using a rudder angle sender with the standard European resistance range (0 ohms at full port 45°, 180 ohms at full starboard 45°).

## 6.11.4 Rudder Number

First, the rudder number must be configured. For a vessel with a single rudder, the number should be set to "0". For a vessel with two rudders, the port rudder should be set to "0" and the starboard rudder should be set to "1". Each rudder must have a rudder number that is different from all other rudders. A screenshot of rudder number configuration is shown in Figure 88 below.

In order to configure the rudder number, use the Scroll Up (⬆) or Scroll Down (⬇) keys to move the highlighted cursor to "Rudder Number:", then press the Enter key (↵) to move the cursor over to the rudder number value. Use the Scroll Up (⬆) or Scroll Down (⬇) keys to select the desired rudder number. Finally, press the Enter key (↵) to confirm your selection and store the new rudder number within the RAA100.



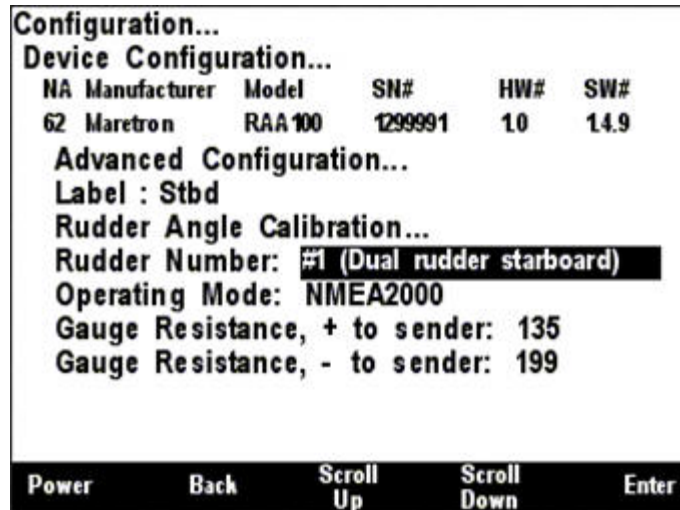


Figure 88 – Setting the Rudder Number

## 6.11.5 Operating Mode

The RAA100 can be operated in one of two operating modes, depending on the installation.

- NMEA 2000 (the only thing that is connected to the resistive sender is the RAA100)
- NMEA 2000 & Analog Gauge (in addition to the RAA100, the resistive sender is also connected to a dual-coil analog gauge).

It is important that this setting be performed correctly in order for the RAA100 to produce correct angle measurements. A screenshot showing configuration of the operating mode appears in Figure 89 below. To configure the operating mode, use the Scroll Up (↑) or Scroll Down (↓) keys to move the highlighted cursor over the “Operating Mode:” menu item, then press the Enter key (↵) to move the highlight over the operating mode value. Use the Scroll Up (↑) or Scroll Down (↓) keys to change the operating mode to the desired value, and finally, press the Entry key to confirm your selection and store the operating mode within the RAA100.

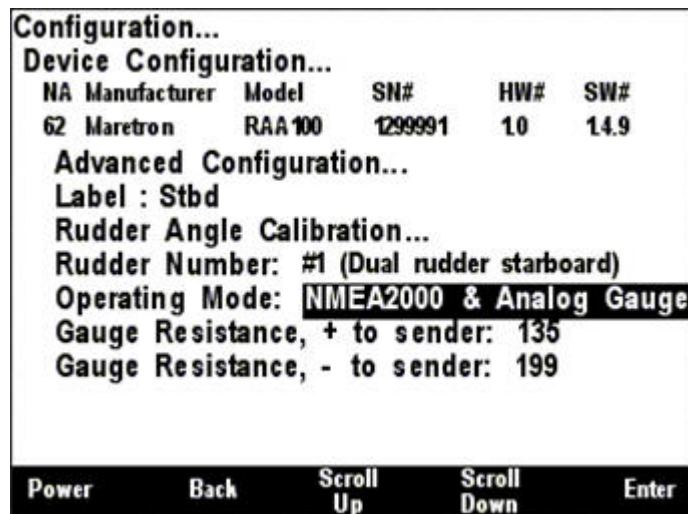


Figure 89 – Setting the Operating Mode

# DSM250 User's Manual

## 6.11.6 Gauge Resistance, + to Sender

If the desired operating mode is “NMEA 2000 & Analog Gauge”, the two gauge resistances must be programmed (please refer to the *RAA100 User's Manual* for details on how to perform these measurements). A screenshot of the + to sender gauge resistance configuration is shown in Figure 90 below. To program the + to sender gauge resistance, use the Scroll Up (↑) or Scroll Down (↓) keys to move the highlighted cursor over the “Gauge Resistance, + to Sender:” menu item. Then, press the Enter key (↵) to move the highlight over the numerical resistance value. Use the “Increase” and “Decrease” keys to change the value to the measured resistance value, and finally, press the Enter key (↵) to confirm your selection and store the value within the RAA100.

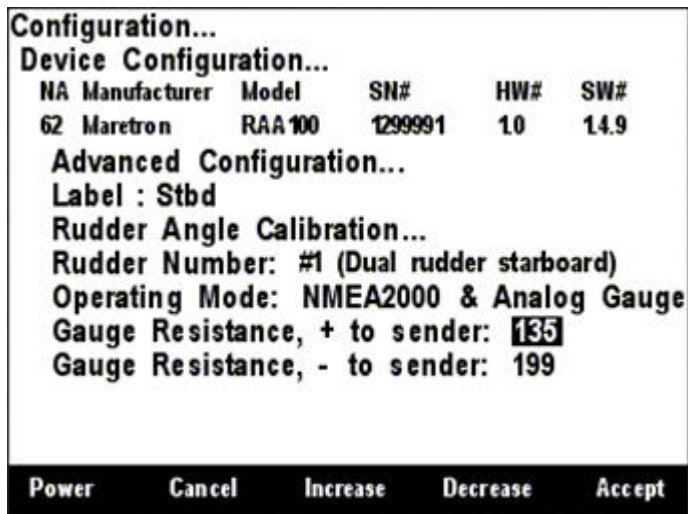
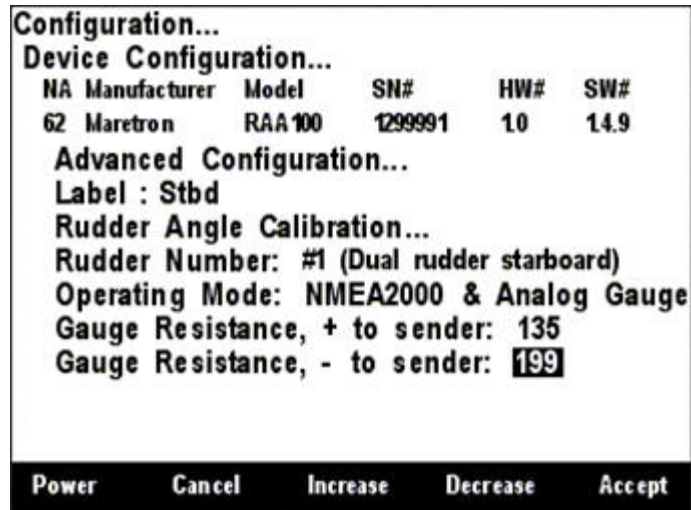


Figure 90 – Setting the + to Sender Gauge Resistance

## 6.11.7 Gauge Resistance, - to Sender

If the desired operating mode is “NMEA 2000 & Analog Gauge”, the two gauge resistances must be programmed (please refer to the *RAA100 User's Manual* for details on how to perform these measurements). A screenshot of the - to sender gauge resistance configuration is shown in Figure 91 below. To program the - to sender gauge resistance, use the Scroll Up (↑) or Scroll Down (↓) keys to move the highlighted cursor over the “Gauge Resistance, - to Sender:” menu item. Then, press the Enter key (↵) to move the highlight over the numerical resistance value. Use the “Increase” and “Decrease” keys to change the value to the measured resistance value, and finally, press the Enter key (↵) to confirm your selection and store the value within the RAA100.





*Figure 91 – Setting the – to Sender Gauge Resistance*

## 6.12 Maretron RIM100 Configuration

This describes the configuration of the Maretron RIM100 firmware version 1.1.1.

The DSM250 may be used to configure the channels on the Run Indicator Module (RIM100).

After selecting the RIM100 from the list of devices on the network, the following screen will be displayed.

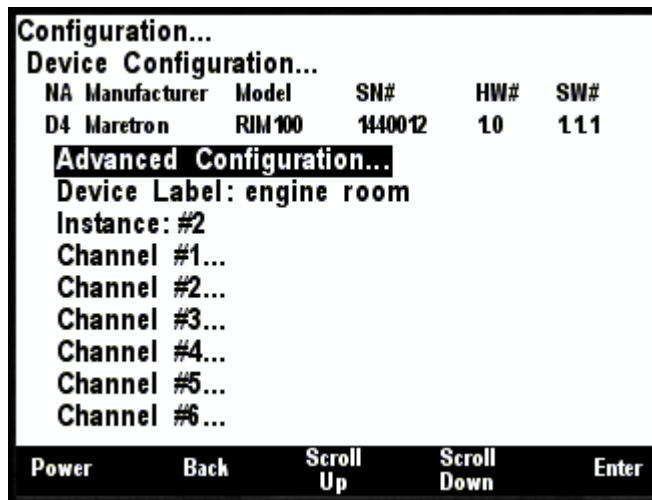


Figure 92 – RIM100 Configuration Screen

### 6.12.1 Advanced Configuration

Advanced Configuration changes some complex parameters within the device, and should only be performed by an advanced user. Typically advanced configuration is only done at installation and should not need to be done while at sea.

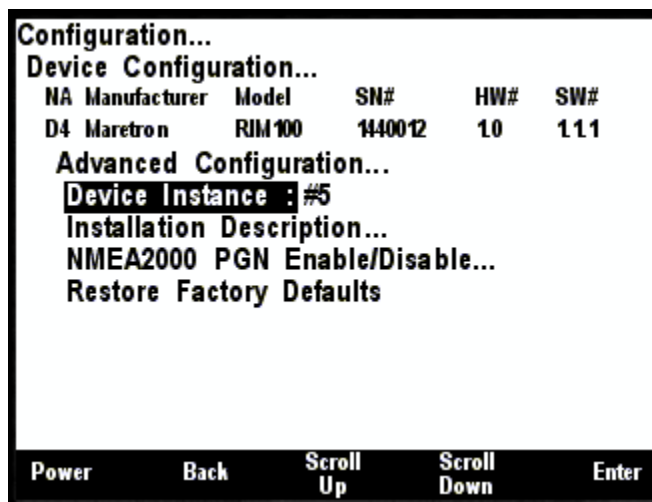


Figure 93 – RIM100 Advanced Configuration Screen

#### 6.12.1.1 Device Instance

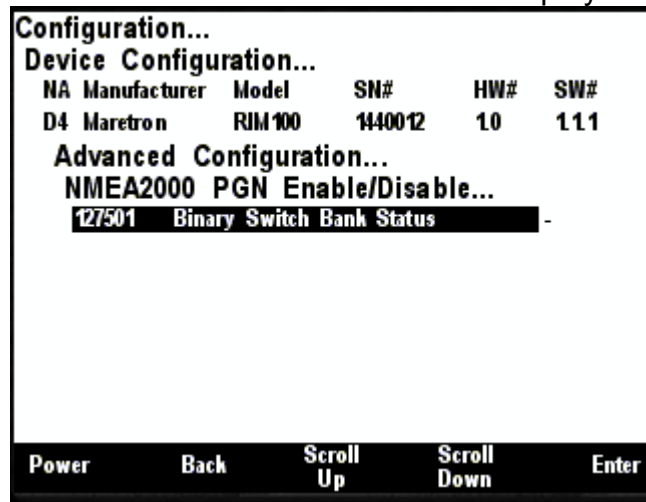
This entry allows you to program the NMEA 2000 device instance for the unit. You usually will not need to modify the default value of “0” unless you have multiple units on the network.

## 6.12.1.2 Installation Description

This entry allows you to modify the NMEA 2000 installation description text strings. You can enter any information you like here, such as the date the unit was installed, or the location in which it was installed, for later reference. Tools such as Maretron N2KAnalyzer allow you to view these values later. See section 3.3.4 for details on how to enter a textual value.

## 6.12.1.3 NMEA2000 PGN Enable/Disable

The RIM100 Run Indicator Module transmits the NMEA2000 PGN #127501 which can be turned on or turned off by the DSM250 display. Pressing the **Enter** key with “NMEA2000 PGN Enable/Disable...” menu item selected causes the DSM250 to display the following screen.



**Figure 94 – RIM100 NMEA 2000® PGN Enable/Disable Screen**

You can enable or disable the transmission of the Binary Switch Status message, or set the frequency of transmission of the message by pressing the Enter key (↵) on the message to be configured. Options are:

- **Disable** – The status message will not be transmitted
- **Default** – The status message will be transmitted at its default NMEA2000 rate, which is once every 15 seconds, and each time the value changes.
- **1s...15s** – The status message will be transmitted at the period specified, and each time the value changes.

Select the required option using the **Scroll Up** and **Scroll Down** keys followed by the **Enter** key.

## 6.12.1.4 Restore Factory Defaults

This option restores all settings on the device to their factory default state.

## 6.12.2 Device Label

A label may be assigned to the RIM100 as an aid to identifying the device over the network. Typically this label will describe the location of the RIM100. See section 3.3.4 for details on how to enter a textual value.

# DSM250 User's Manual

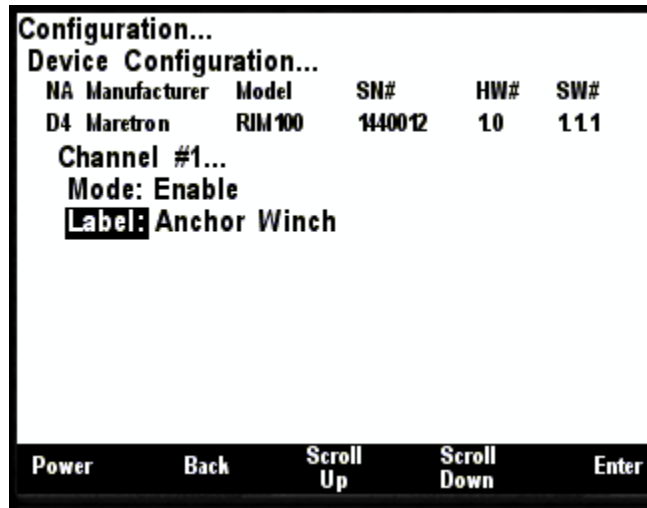
---

## 6.12.3 Instance

From here the instance used in the data message may be set.

## 6.12.4 Channel Configuration

To configure an individual channel, use the Scroll Up and Scroll Down buttons to highlight the channel, and then press Enter. The following screen will be displayed.



*Figure 95 – RIM100 Channel Configuration Screen*

### 6.12.4.1 Mode

Each Channel may be enabled or disabled. Valid Modes are:

**Disable** – the channel is not being used

**Enable**– the channel is being used

Select the required option using the **Scroll Up** and **Scroll Down** keys followed by the **Enter** key.

### 6.12.4.2 Label

A label may be assigned to a channel as an aid to identifying the channel over the network. Typically this label will describe the equipment to which the channel is connected.

See section 3.3.4 for details on how to enter a textual value.

## 6.13 Maretron SIM100 Configuration

This describes the configuration of the Maretron SIM100 firmware version 1.1.1.

The DSM250 may be used to configure the channels on the Switch Indicator Module (SIM100). After selecting the SIM100 from the list of devices on the network, the following screen will be displayed.

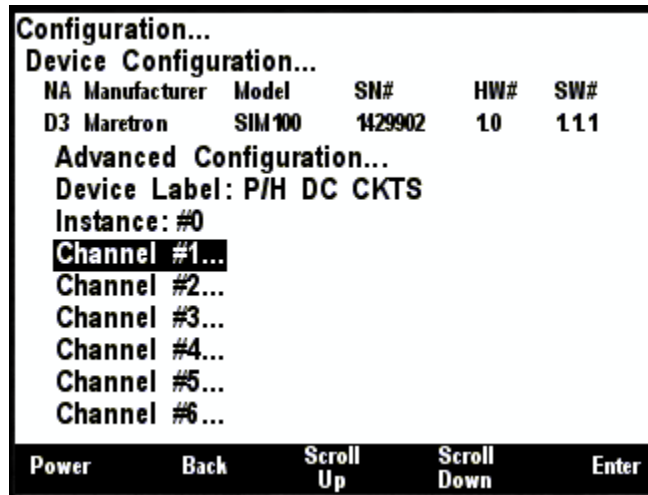


Figure 96 – SIM100 Configuration Screen

### 6.13.1 Advanced Configuration

Advanced Configuration changes some complex parameters within the device, and should only be performed by an advanced user. Typically advanced configuration is only done at installation and should not need to be done while at sea.

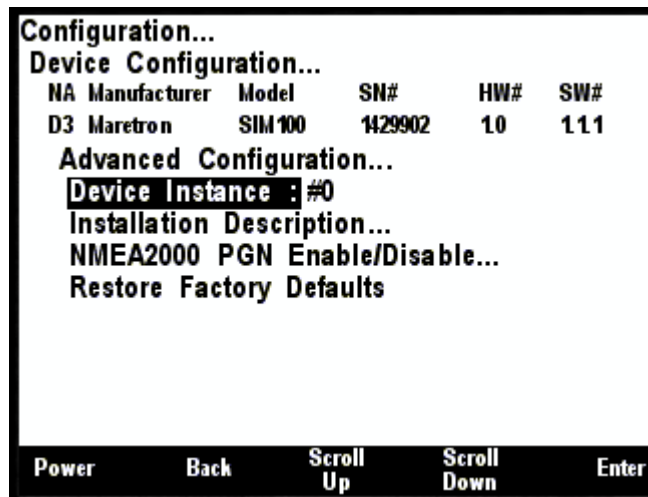


Figure 97 – SIM100 Advanced Configuration Screen

#### 6.13.1.1 Device Instance

This entry allows you to program the NMEA 2000 device instance for the unit. You usually will not need to modify the default value of “0” unless you have multiple units on the network.

# DSM250 User's Manual

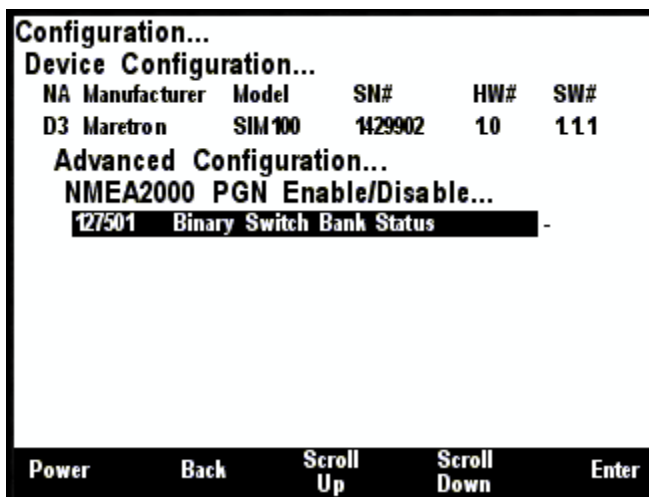
---

## 6.13.1.2 Installation Description

This entry allows you to modify the NMEA 2000 installation description text strings. You can enter any information you like here, such as the date the unit was installed, or the location in which it was installed, for later reference. Tools such as Maretron N2KAnalyzer allow you to view these values later. See section 3.3.4 for details on how to enter a textual value.

## 6.13.1.3 NMEA2000 PGN Enable/Disable

The SIM100 Switch Indicator Module transmits the NMEA2000 PGN #127501 which can be turned on or turned off by the DSM250 display. Pressing the **Enter** key with “NMEA2000 PGN Enable/Disable...” menu item selected causes the DSM250 to display the following screen.



*Figure 98 –SIM100 NMEA 2000® PGN Enable/Disable Screen*

You can enable or disable the transmission of the Binary Switch Status message, or set the frequency of transmission of the message by pressing the Enter key (↵) on the message to be configured. Options are:

- **Disable** – The status message will not be transmitted
- **Default** – The status message will be transmitted at its default NMEA2000 rate, which is once every 15 seconds, and each time the value changes.
- **1s...15s** – The status message will be transmitted at the period specified, and each time the value changes.

Select the required option using the **Scroll Up** and **Scroll Down** keys followed by the **Enter** key.

## 6.13.1.4 Restore Factory Defaults

This option restores all settings on the device to their factory default state.

## 6.13.2 Device Label

A label may be assigned to the SIM100 as an aid to identifying the device over the network. Typically this label will describe the location of the SIM100. See section 3.3.4 for details on how to enter a textual value.

### 6.13.3 Instance

From here the instance used in the data message may be set.

### 6.13.4 Channel Configuration

To configure an individual channel, use the Scroll Up and Scroll Down buttons to highlight the channel, and then press Enter. The following screen will be displayed.

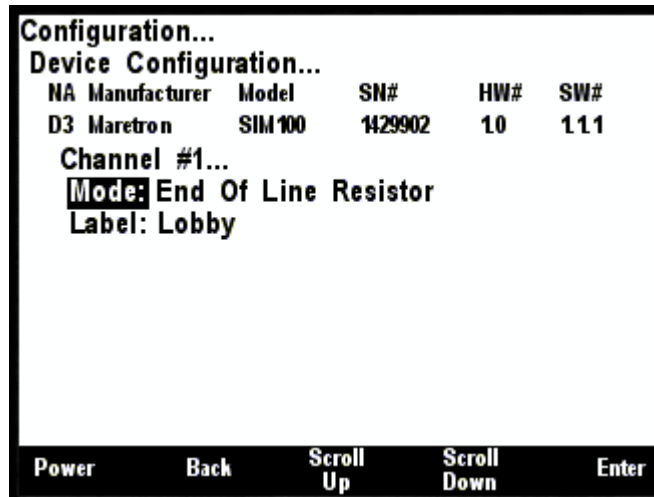


Figure 99 – SIM100 Channel Configuration Screen

#### 6.13.4.1 Mode

To be able to detect broken connections, a SIM100 channel may be configured to detect an 8kΩ resistor at the end of the circuit in the open state. In this case a fully open circuit will reported as a fault condition. See the manual for details.

Valid Modes are:

**Disable** – the channel is not being used

**End Of Line Resistor** – an open circuit is a fault condition.

**No End Of Line Resistor** – an open circuit is not a fault condition.

Select the required option using the **Scroll Up** and **Scroll Down** keys followed by the **Enter** key.

#### 6.13.4.2 Label

A label may be assigned to a channel as an aid to identifying the channel over the network. Typically this label will describe the function of the switch connected to the channel.

See section 3.3.4 for details on how to enter a textual value.

## 6.14 Maretron SSC200 Configuration

This describes the configuration of the Maretron SSC200 firmware version 2.0.11. Nine configurable parameters for the Maretron SSC200 solid state compass may be configured using the Maretron DSM250 display. The Maretron SSC200 configuration menu can be seen in Figure 100 below.

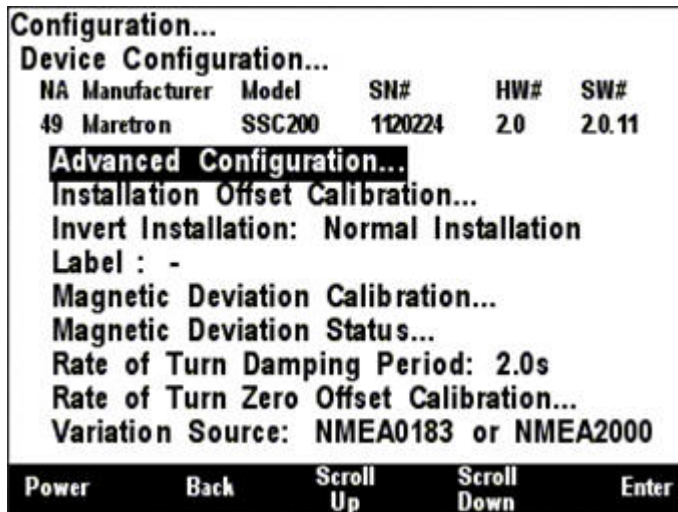


Figure 100 –SSC200 Configuration Screen

### 6.14.1 Advanced Configuration

Advanced Configuration changes some complex parameters within the device, and should only be performed by an advanced user. Typically advanced configuration is only done at installation and should not need to be done while at sea.

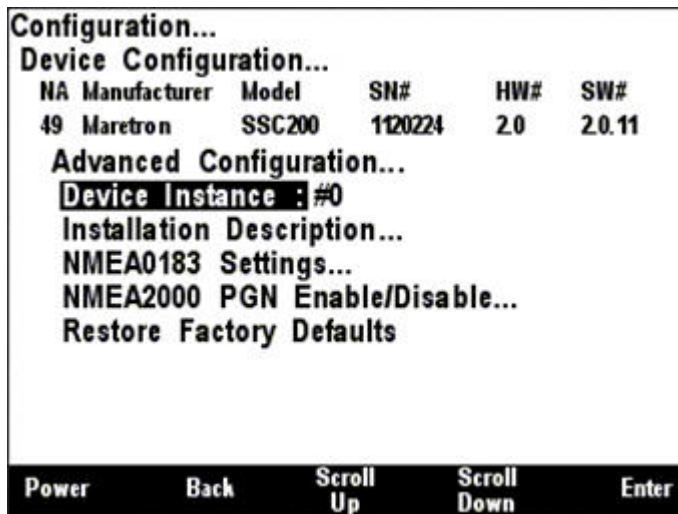


Figure 101 –SSC200 Advanced Configuration Screen

#### 6.14.1.1 Device Instance

This entry allows you to program the NMEA 2000 device instance for the unit. You usually will not need to modify the default value of “0” unless you have multiple units on the network.



## 6.14.1.2 Installation Description

This entry allows you to modify the NMEA 2000 installation description text strings. You can enter any information you like here, such as the date the unit was installed, or the location in which it was installed, for later reference. Tools such as Maretron N2KAnalyzer allow you to view these values later. See section 3.3.4 for details on how to enter a textual value.

## 6.14.1.3 NMEA0183 Settings

Several characteristics of the NMEA 0183 interface of the SSC200 may be programmed using the DSM250 display. This can be used for initial programming of a SSC200 compass even if only the NMEA 0183 interface is to be used after installation is complete. The figure below shows the possible programming options for the NMEA 0183 interface.

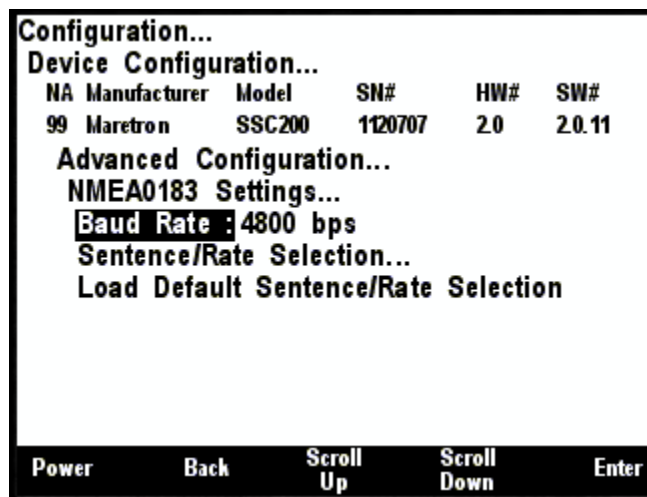


Figure 102 –SSC200 NMEA 0183 Settings Screen

### 6.14.1.3.1 Baud Rate

The SSC200 compass supports NMEA0183 communication at both 4800 baud and 38400 baud. All SSC200 Compasses are shipped with a baud rate of 4800 baud. This value may be changed by selecting the Baud Rate option in the menu, and pressing **Enter**. The use the **Scroll Up** and **Scroll Down** buttons to select the desired baud rate and press **Enter** to save the value.

### 6.14.1.3.2 Sentence / Rate Selection

The NMEA 0183 interface is a very low bandwidth interface. The SSC200 is capable of transmitting a wide variety of NMEA 0183 sentences, and can exceed the bandwidth of the NMEA 0183 interface if all sentences are transmitted at maximum rates, causing lost data in NMEA 0183 multiplexers or on the SSC200 interface itself. It is important, therefore, to limit the types of NMEA 0183 sentences transmitted only to those that are necessary for other products which are connected to the NMEA 0183 interface. Figure 103 below shows the SSC200 NMEA 0183 Settings -> Sentence/Rate Selection menu. In this menu, you can selectively enable and disable the different NMEA 0183 sentences that the SSC200 can transmit, and you can program the transmission interval for the enabled sentences. In the figure, you can see that the HDG and ROT sentences will be transmitted every 0.1 second (10 times/second), the ATT sentence will be transmitted once per second, and the HDM and HDT sentences are disabled.

# DSM250 User's Manual

The last line in the menu enables you to program the lifetime of the variation data received by the SSC200. In Figure 103, you can see that the "Variation Time" has been programmed to 5.0 seconds. This means that if the compass has not received magnetic variation for five seconds, it will no longer transmit true heading data, as the variation data it has received is now expired. On the NMEA2000 side, the Heading PGN has separate fields for heading sensor reading and variation. The SSC200 always has magnetic heading available; when variation is not available (timeout or invalid) the variation field is set to N/A. The default value of 5.0 seconds should be adequate for the majority of applications, but it may need to be increased for variation sources that transmit less frequently.

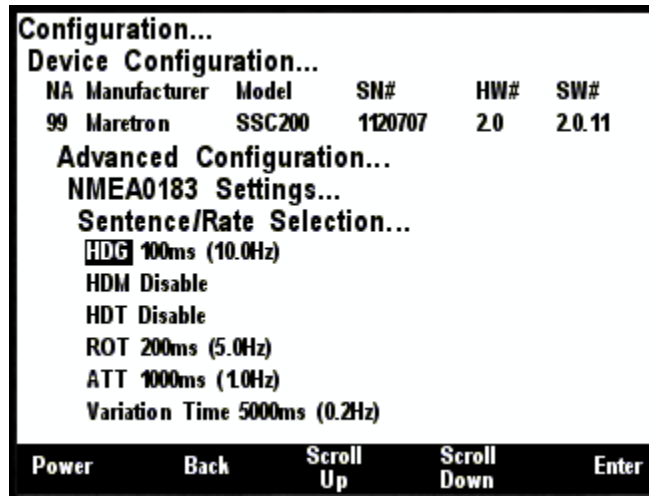


Figure 103 – SSC200 NMEA 0183 Sentence/Rate Selection Screen

### 6.14.1.3.3 Load Default Sentence / Rate Selection

The Load Default Sentence / Rate Selection option will reset the NMEA 0183 sentence enable/disable status, along with transmission intervals and variation time, to their factory default settings.

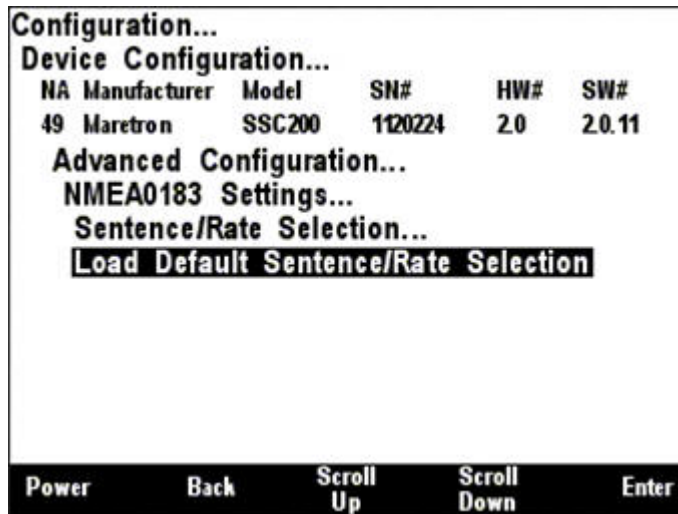
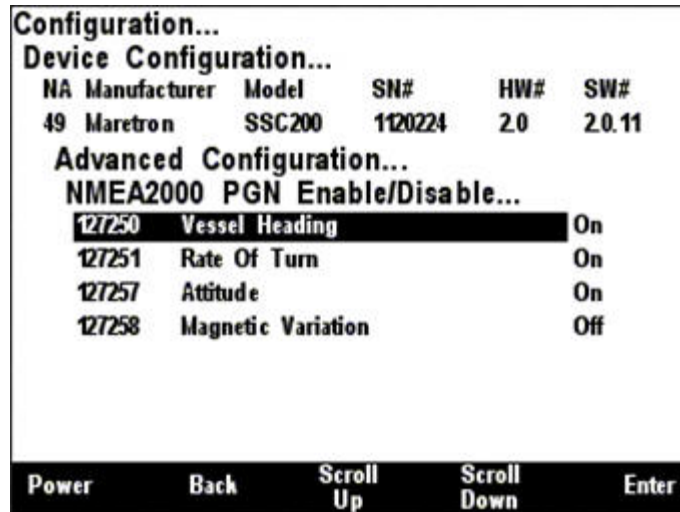


Figure 104 – SSC200 Load Default Periodic Rate Selection

## 6.14.1.4 NMEA2000 PGN Enable/Disable

The SSC200 compass transmits several different messages, which can be turned on or turned off by the DSM250 display. Pressing the **Enter** key (↵) with “NMEA2000 PGN Enable/Disable...” menu item selected causes the DSM250 to display the following screen.



**Figure 105 –SSC200 NMEA 2000® PGN Enable/Disable Screen**

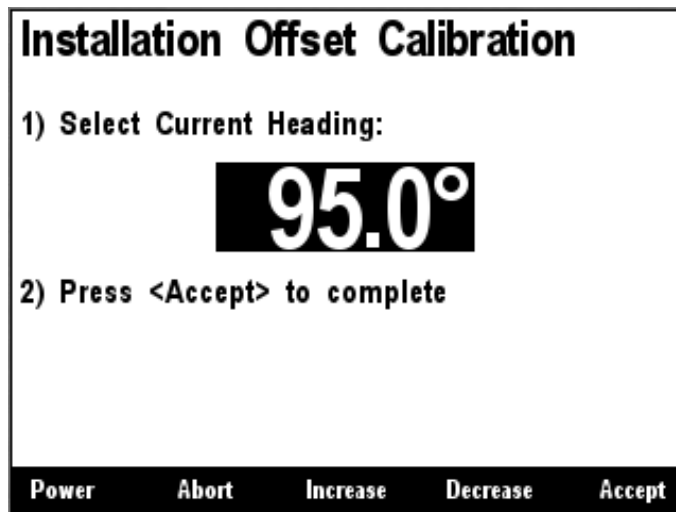
You can enable or disable specific transmissions by scrolling (↑ or ↓) through the different transmitted messages and pressing the Enter key (↵) on the message to be configured. Select whether you want the message to be transmitted (“On”) or disabled (“Off”) using the Scroll Up (↑) or Scroll Down (↓) keys followed by the Enter key (↵).

## 6.14.1.5 Restore Factory Defaults

This option restores all settings on the device to their factory default state.

## 6.14.2 Installation Offset Calibration

The installation offset (i.e., misalignment of installed SSC200 with vessels center line) may be calibrated using the Maretron DSM250 display. While executing “Installation Offset Calibration”, the vessel must stay still with no pitch and roll because SSC200 will also calibrate pitch and roll at this time. Once the compass is installed, point the vessel at a known heading, and then select the compass from the “Device Configuration...” menu. Scroll down (↓) the menu items to the line entitled “Installation Offset Calibration...” and press enter (↵) which takes you to the screen shown below.

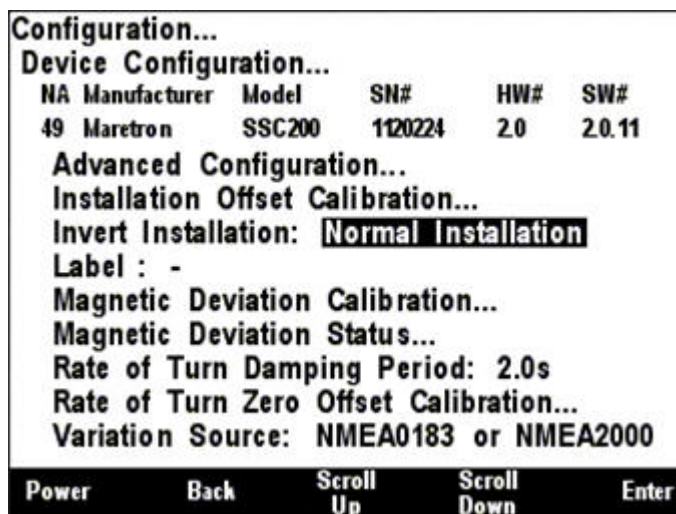


*Figure 106 –SSC200 Installation Offset Calibration Screen*

Use the Increase (↑) and Decrease (↓) keys to adjust the display value until it matches the known heading to which the boat is pointed. Press the Accept (↵) key to accept the value when you are satisfied. If you do not wish to perform installation offset calibration at this time, press the Abort (⏻) key and the installation offset will not be altered.

### 6.14.3 Inverted Installation Entry

Normally, the SSC200 is mounted so that the label on the compass is facing up and the NMEA 2000® and NMEA 0183 connectors are facing towards the bow of the vessel. A recent version of SSC200 firmware supports mounting the compass upside-down (for instance, to a ceiling), or backwards (with connectors facing towards the stern of the vessel, so that the SSC200 can be mounted to the aft side of a bulkhead). If either of these mounting options is used, the DSM250 can be used to inform the SSC200 of this fact so that it can adjust heading, rate or turn, pitch, and roll readings to be corrected accordingly.



*Figure 107 – Setting the Installation Orientation*

The choices that are offered are “Normal Installation” (default), “Backward Installation”, “Upside-Down Installation”, or “Upside Down and Backward”.

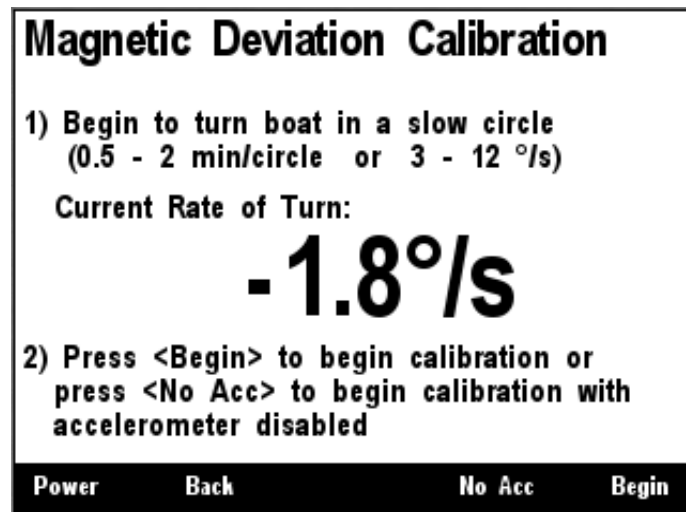
## 6.14.4 Label

This menu item allows you to set a text label for the device. This text label will help you to identify a particular device when you have more than one of the same type in the system, and appears when selecting devices in both the DSM250 and in N2KView.

See section 3.3.4 for details on how to enter a textual value.

## 6.14.5 Magnetic Deviation Calibration

The DSM250 is capable of performing magnetic deviation calibration on a Maretron SSC200 solid state compass. The Rate of Turn Offset Calibration (section 6.14.8) should be done before the Deviation Calibration. The first screen (Figure 108) gives instructions for performing the procedure. First, begin to turn the boat in a slow circle (either clockwise or counter-clockwise) at about 3 to 12 degrees per second.



*Figure 108 –SSC200 Magnetic Deviation Calibration Start Screen*

Once you have begun the turn, press Begin (⊕) to start the calibration procedure. If you do not wish to perform magnetic deviation calibration at this time, press Abort (⊗), and the currently stored deviation tables will be retained. If you are in a large vessel, it may be difficult to turn the vessel in a small enough circle to avoid significant centrifugal force applied to the compass during magnetic deviation calibration. This can cause the built-in tilt sensors inside the compass to mistakenly believe that the compass is tilted during the magnetic deviation calibration, which can adversely affect the quality of the magnetic deviation calibration, especially in northerly latitudes where magnetic inclination (magnetic dip) is higher. If this is the case, instead of pressing the Begin (⊕) key, press the No Acc(⊗) key. This will cause the compass to ignore its tilt sensors and assume that the compass is level to the earth’s surface during the calibration. You must keep the boat level during calibration if you choose this option. After you press the Begin (⊕) key or the No Acc(⊗) key, a status screen will appear (Figure 109).

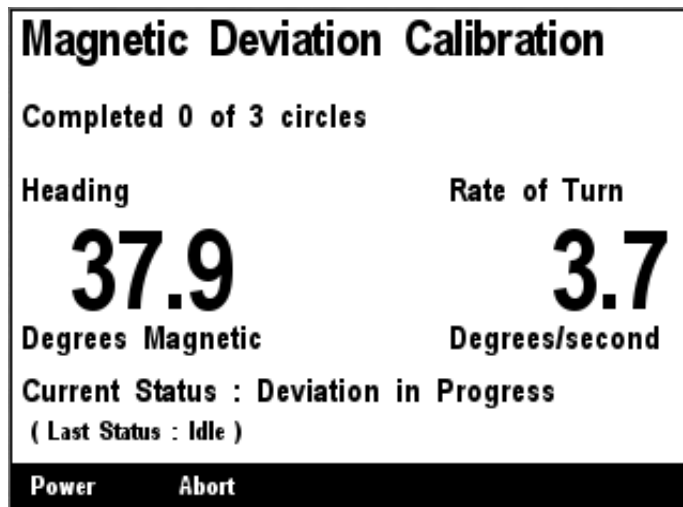


Figure 109 –SSC200 Magnetic Deviation Calibration Progress Screen

This progress screen shows the number of circles completed, the current heading, the current rate of turn, and the current status of compass calibration. If you do not wish to continue magnetic deviation calibration at this time, press Abort (⏏), and the currently stored deviation tables will be retained. Once calibration is successful, a completion screen will appear. If calibration is unsuccessful, a screen will appear indicating this, and you should repeat the calibration procedure.

## 6.14.6 Magnetic Deviation Status

Pressing the Enter key (↵) with the “Magnetic Variation Status...” menu item selected causes the screen shown in Figure 110 to be displayed.

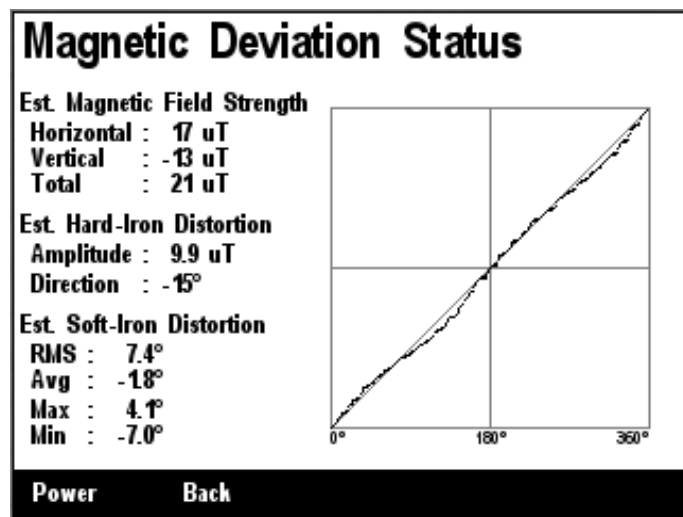


Figure 110 –SSC200 Magnetic Deviation Status Screen

## 6.14.7 Rate of Turn Damping Period

The SSC200 is capable of transmitting the rate of turn of a vessel. Different applications may require different damping for the rate of turn measurement. The DSM250 may be used to set the damping period for the rate of turn measurement to anywhere between 0.1 seconds and 60 seconds. Figure 111 shows an example of the damping period set to 2 seconds.



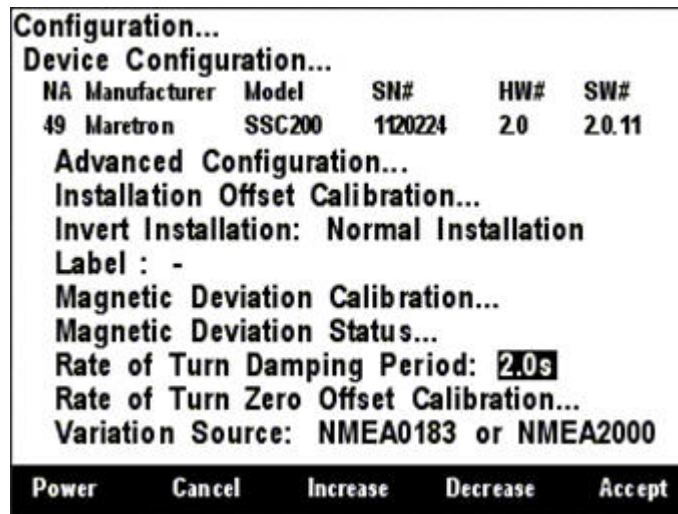


Figure 111 – Programming SSC200 Rate of Turn Damping Period

### 6.14.8 Rate of Turn Zero Offset Calibration

The DSM250 is capable of displaying rate of turn information from a Maretron SSC200 compass. Although the compass provides very accurate rate of turn information, it can drift off of zero even though the vessel is not turning. Fortunately, the SSC200 can learn the zero offset for different conditions found on the vessel. You teach the compass these zero offset values by pressing the Enter key (↵) with the “Rate of Turn Zero Offset Calibration...” menu item selected which causes the DSM250 to display the screen shown in Figure 112. The Rate of Turn Offset Calibration should be done before the Deviation Calibration (section 6.14.5).

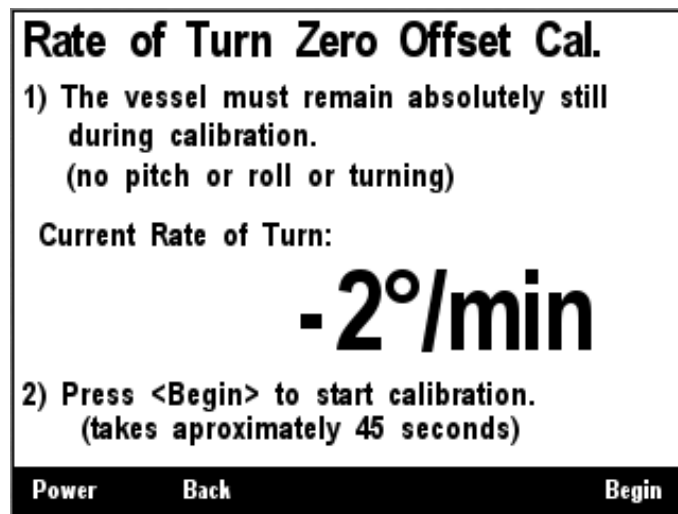


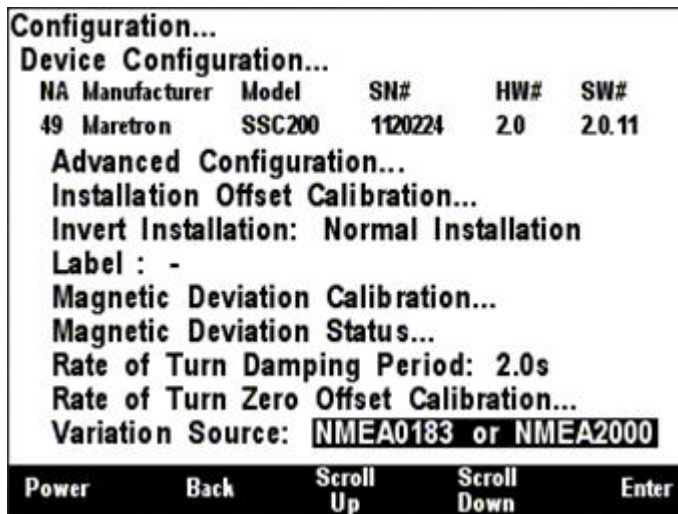
Figure 112 –SSC200 Rate of Turn Zero Offset Calibration Screen

### 6.14.9 Variation Source Entry

The SSC200, being a magnetic compass, transmits heading information referenced to the magnetic north pole (magnetic heading). The SSC200 is capable of transmitting heading information referenced to the earth’s geographic North Pole (true heading). In order to produce true heading,

# DSM250 User's Manual

information regarding the magnetic variation at the current location is required. Please see the *SSC200 User's Manual* for more details on the use of magnetic variation by the SSC200 compass. By default, the SSC200 is capable of receiving variation information on either its **NMEA 0183** or **NMEA 2000**® interfaces. This causes the SSC200 to use variation data from either the NMEA 0183 interface or the NMEA 2000® interface.

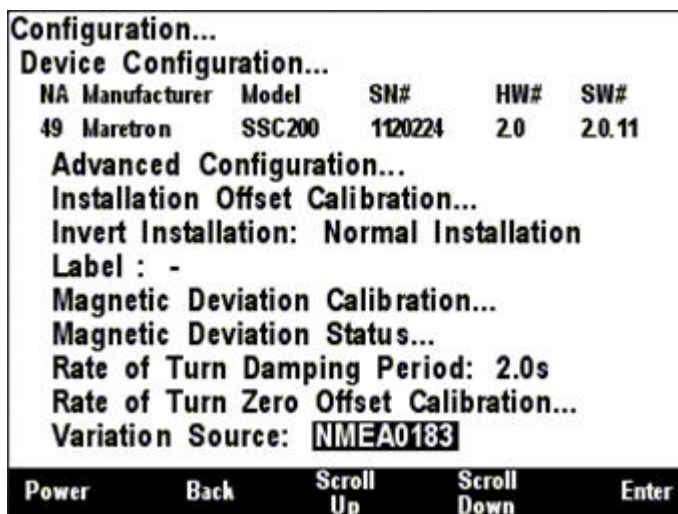


*Figure 113 – Setting Variation Source to NMEA 0183 or NMEA 2000® (factory default)*

You should need to alter this setting only if:

- There are variation sources available on both the NMEA 2000® and NMEA 0183 interfaces, or
- There is no magnetic variation source available.

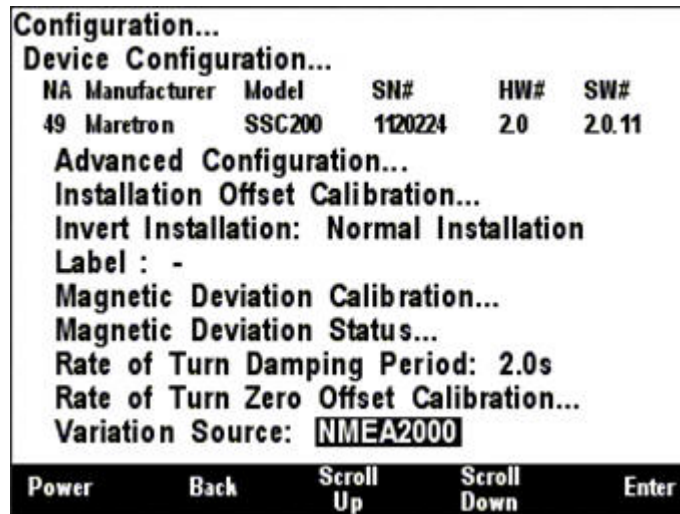
If variation sources are available on both the NMEA 2000® and NMEA 0183 interfaces, you must tell the SSC200 which source to use. Figure 114 below shows the NMEA 0183 source selected. This causes the SSC200 to use variation data from the NMEA 0183 interface and ignore all other variation sources (i.e., NMEA 2000® interface and manual entries).



*Figure 114 – Setting Variation Source to NMEA 0183 Only*

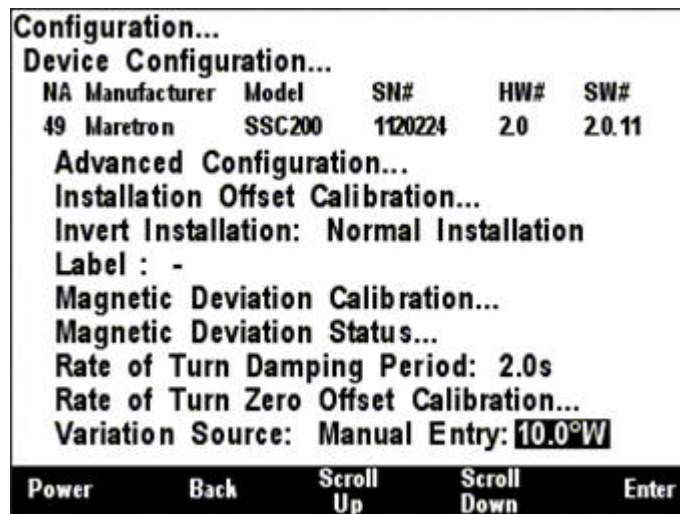


Figure 115 below shows the NMEA 2000® source selected.



**Figure 115 – Setting Variation Source to NMEA 2000® Only**

If there is no magnetic variation source available on either the NMEA 2000® or the NMEA 0183 interface, and you wish to display true heading information, you may manually enter a magnetic variation. To set a manual variation value, you must change the variation source by pushing the Enter key (↵) with the “Variation Source:” menu item selected. This highlights the next field where you select “Manual Entry:” by scrolling (↑ or ↓) through the options until you reach “Manual Entry:”. Pressing the Enter key (↵) with the “Manual Entry:” menu item selected takes you to the screen shown in Figure 116.



**Figure 116 – Entering Manual Variation**

Press the Scroll Up (↑) or Scroll Down (↓) key to change the amount of East or West variation. Press the Accept Key (↵) when the desired number is shown. You may also disable manual variation by setting the value to “Disable”; this option appears between the values 0.0°E and 0.1°W when scrolling through the values. When manual variation is disabled, the SSC200 will not transmit any variation information and heading information will be available only in magnetic heading format.

# DSM250 User's Manual

---

**WARNING:** Magnetic variation changes as your location on the earth changes; therefore magnetic variation should be adjusted with changes in position. Neither the DSM250 nor the SSC200 will make these changes automatically; they are the responsibility of the user.

## 6.15 Maretron TLA100 Configuration

Maretron TLA100 tank level adapters on the network may be configured using the DSM250. This describes the configuration of the Maretron TLA100 firmware version 1.6.14. The TLA100 configuration menu is shown in Figure 117 below.

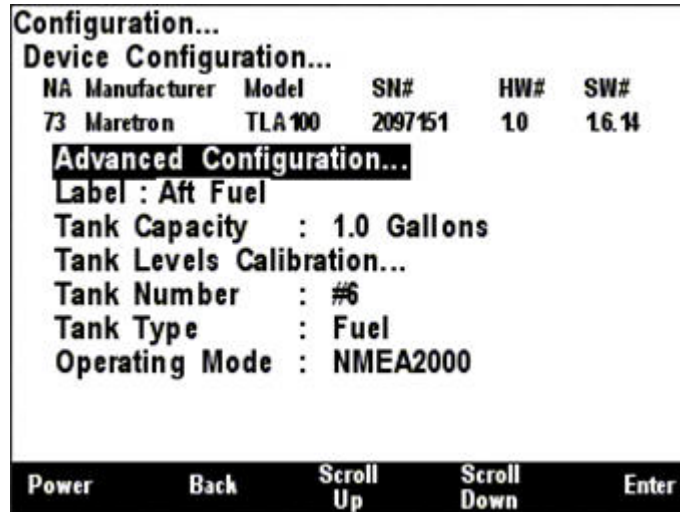


Figure 117 – TLA100 Configuration Screen

### 6.15.1 Advanced Configuration

Advanced Configuration changes some complex parameters within the device, and should only be performed by an advanced user. Typically advanced configuration is only done at installation and should not need to be done while at sea.

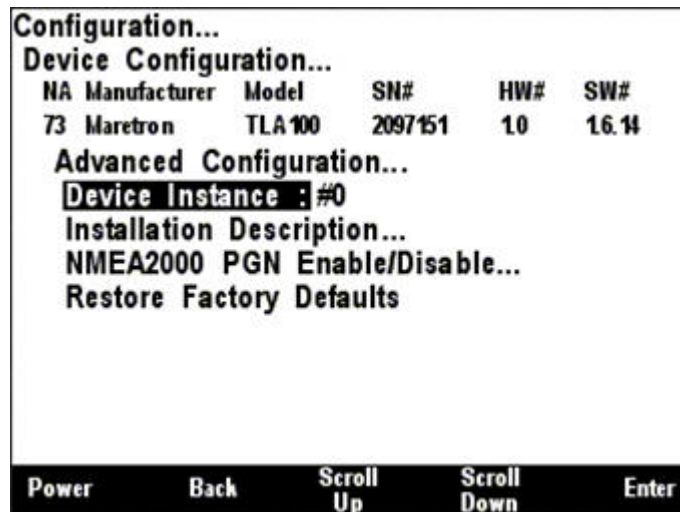


Figure 118 – TLA100 Advanced Configuration Screen

#### 6.15.1.1 Device Instance

This entry allows you to program the NMEA 2000 device instance for the unit. You usually will not need to modify the default value of "0" unless you have multiple units on the network.

# DSM250 User's Manual

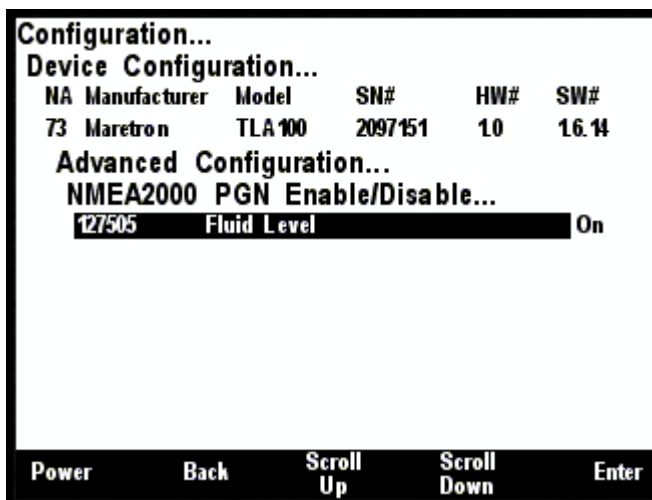
---

## 6.15.1.2 Installation Description

This entry allows you to modify the NMEA 2000 installation description text strings. You can enter any information you like here, such as the date the unit was installed, or the location in which it was installed, for later reference. Tools such as Maretron N2KAnalyzer allow you to view these values later. See section 3.3.4 for details on how to enter a textual value.

## 6.15.1.3 NMEA2000 PGN Enable/Disable

The TLA100 Tank Level Adapter transmits the NMEA2000 PGN #127505 which can be turned on or turned off by the DSM250 display. Pressing the **Enter** key with "NMEA2000 PGN Enable/Disable..." menu item selected causes the DSM250 to display the following screen.



*Figure 119 –TLA100 NMEA 2000® PGN Enable/Disable Screen*

You can enable or disable the transmission of the Fluid Level message, or set the frequency of transmission of the message by pressing the Enter key (⏎) on the message to be configured. Options are:

- **Off** – The status message will not be transmitted
- **On** – The status message will be transmitted at its default NMEA2000 rate.

Select the required option using the **Scroll Up** and **Scroll Down** keys followed by the **Enter** key.

## 6.15.1.4 Restore Factory Defaults

This option restores all settings on the device to their factory default state.

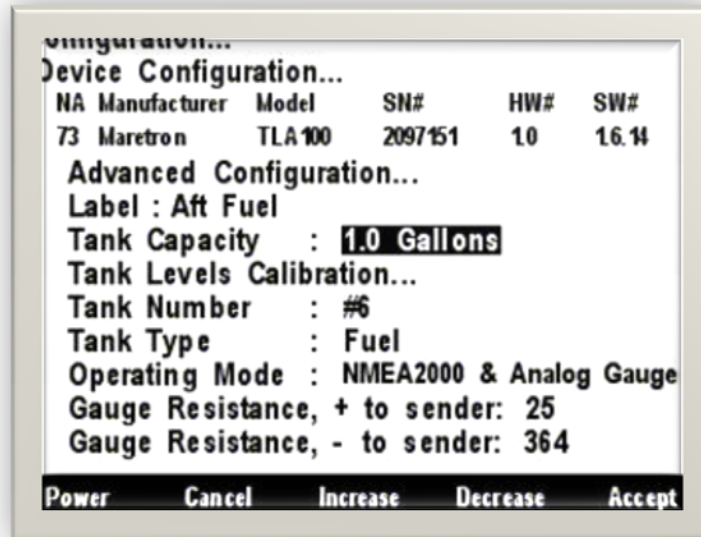
## 6.15.2 Label

See section 3.3.4 for details on how to enter a textual value.

## 6.15.3 Tank Capacity

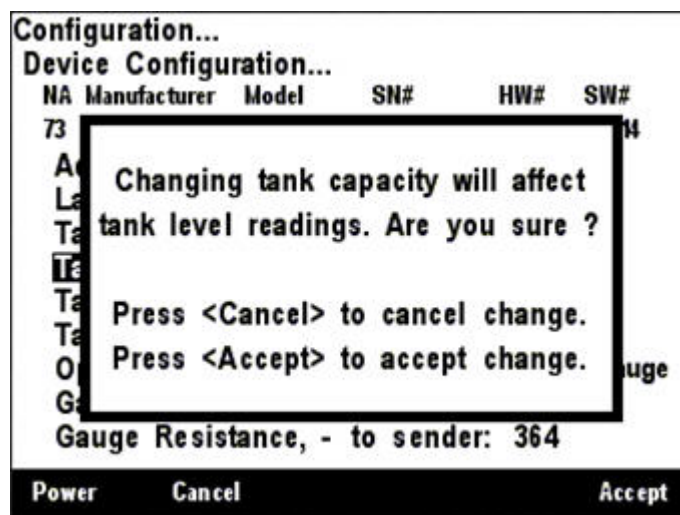
In order for the TLA100 to produce readings of the amount of fluid remaining in the tank, the tank capacity must be programmed into the TLA100 adapter. Figure 120 below shows a screen shot of the tank capacity being configured.

To program the tank capacity, use the Scroll Up (↑) or Scroll Down (↓) keys to move the highlighted cursor over the “Tank Capacity:” menu item. Then, press the Enter key (↵) to move the highlight over the numerical tank capacity value. Use the “Increase” and “Decrease” keys to change the value to the desired tank capacity value, and finally, press the Enter key (↵) to confirm your selection and store the value within the TLA100.



**Figure 120 – Configuring the Tank Capacity**

After you have pressed the Enter key (↵), a confirmation screen will appear that warns you that the fluid remaining measurement will change as a result of this change. Press the Accept key to accept the change and store the new tank capacity value within the TLA100, or Press the Cancel Key (⊗) to cancel the change and leave the old tank capacity programmed into the TLA100.



**Figure 121 – Tank Capacity Change Confirmation Screen**

#### 6.15.4 Tank Levels Calibration

In order for the TLA100 to indicate an accurate tank level, it must know how the resistance of the resistive tank level sender corresponds to the level of fluid in the tank. There are three methods of calibrating the tank level sender:

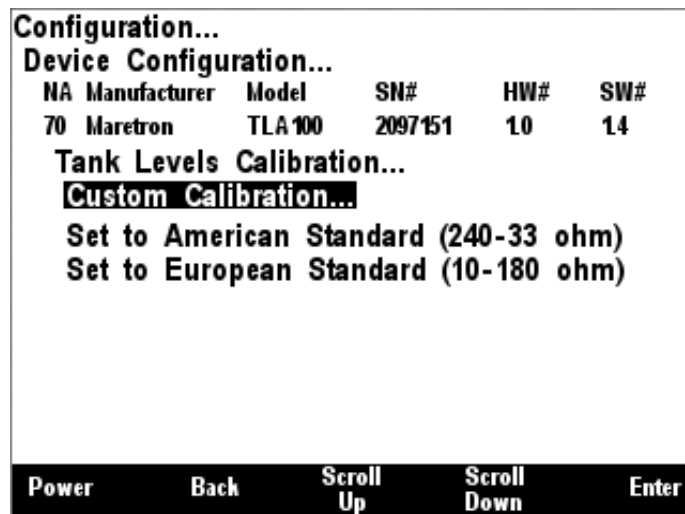
# DSM250 User's Manual

---

- Custom Calibration – use for non-rectangular tanks or non-standard sensors (also, most accurate in any case, but requires more effort)
- Set to American Standard (240-33 ohm) – use for rectangular tanks using a tank level sender with the standard American resistance range (240 ohms at full, 33 ohms at empty).
- Set to European Standard (0-180 ohm) – use for rectangular tanks using a tank level sender with the standard European resistance range (0 ohms at full, 180 ohms at empty).

## 6.15.4.1 Custom Calibration

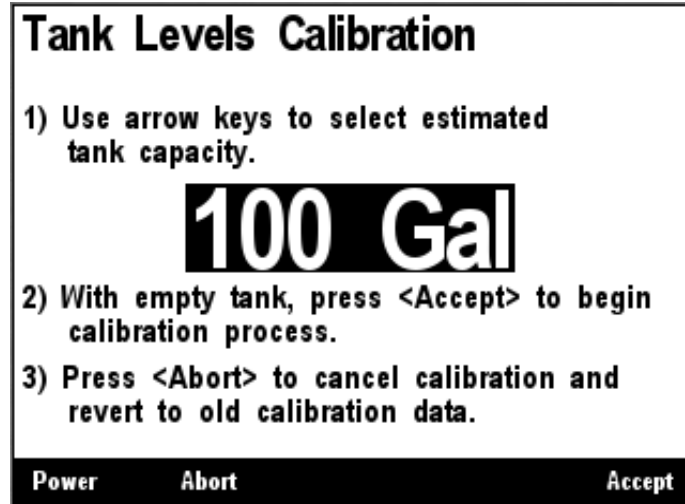
The Custom Calibration setting will provide the most accurate tank level readings under any circumstances, but it requires that you go through a process in which you gradually fill the tank, stopping periodically to input the current fluid level. The TLA100 will measure the sender resistance at each point and create a custom calibration map which relates the resistance of the sender with the fluid levels. Figure 122 below shows a screenshot of the DSM250 with the Custom Calibration option highlighted. Custom calibration is necessary for non-rectangular tanks and for non-standard values of resistances for tank level senders. To perform custom calibration of the tank level sender, use the Scroll Up (↑) or Scroll Down (↓) keys to move the highlighted cursor over the “Custom Calibration...” menu item. Then, press the Enter key (↵) to confirm your selection and begin the calibration process.



**Figure 122 – Performing Custom Calibration of the Tank Level Adapter**

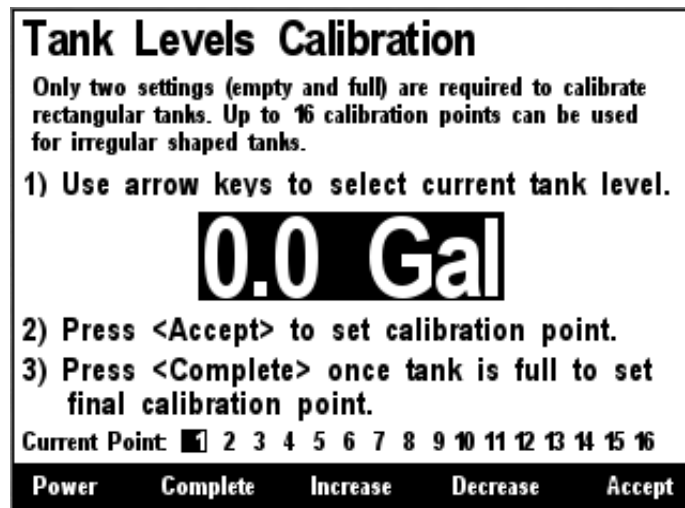
The first step in custom calibration of the tank level sender is to provide an estimated capacity of the tank. This estimated capacity must be within +/- 25% of the actual capacity. To set the estimated tank capacity, use the arrow keys to adjust the displayed value until the desired value is shown. Then, press the Accept key to confirm your selection and continue with the calibration process. If you desire to stop the calibration process, pressing the **Back** Key (⏪) will end the process and return you to the Tank Levels Calibration menu.





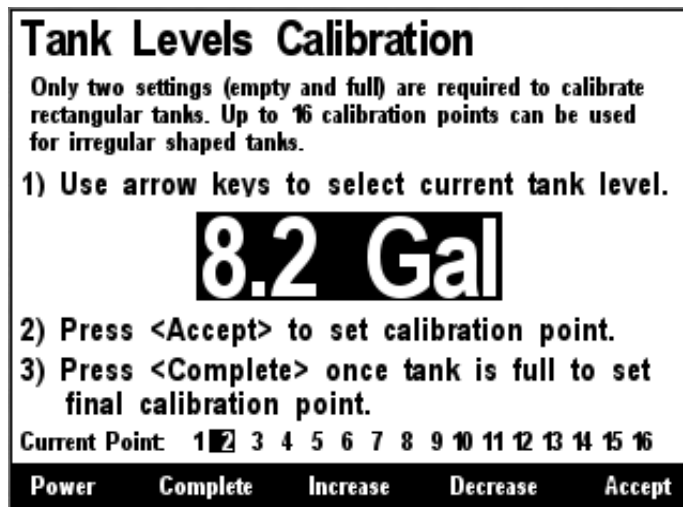
*Figure 123 – Tank Levels Calibration Capacity Estimation*

The next step in the calibration process is to fill the tank and indicate the volume of fluid in the tank at various points while filling the tank. This process should be started with an empty tank. You only need to indicate two calibration points for a rectangular tank, and can use up to 16 calibration points for a tank with a more complex shape. Figure 124 shows a screenshot of the first calibration step. Enter the first calibration point with an empty tank (0.0 Gallons/liters) by pressing the **Accept** key. The “Current Point” highlight will advance to the next point.



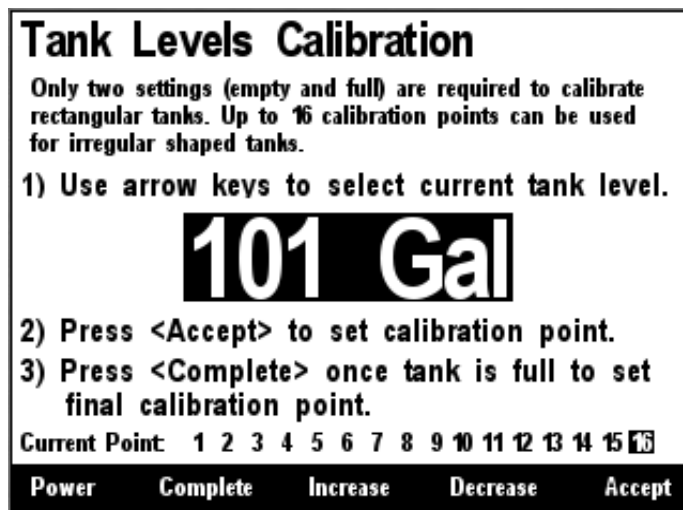
*Figure 124 – Empty Level Calibration*

Each time you press **Accept** during this process and after the Current Point highlight advances, put more fluid into the tank, and note the total volume of fluid pumped into the tank at this point. Use the **Increase** and **Decrease** keys to set the current tank level to the appropriate value, and then press the **Accept** key to store the current calibration point and advance to the next calibration point. Figure 125 shows a screenshot of these intermediate calibration points.



*Figure 125 – Intermediate Level Calibration*

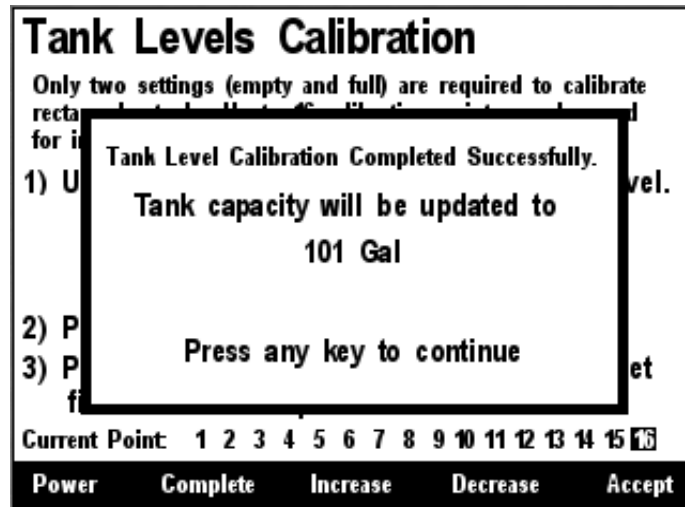
Once the tank is completely full, instead of pressing the **Accept** key to store the current calibration point, press the **Complete** key. This will complete the calibration process and will also adjust the tank capacity to the currently indicated level. Figure 126 below shows the calibration screen at the last point with the full tank level (and thus the tank capacity) set to 101 gallons.



*Figure 126 – Full Level Calibration*

After you press accept, a confirmation screen will appear showing completion of the calibration process and the new tank capacity value. A screenshot of this calibration screen is shown below in Figure 127.

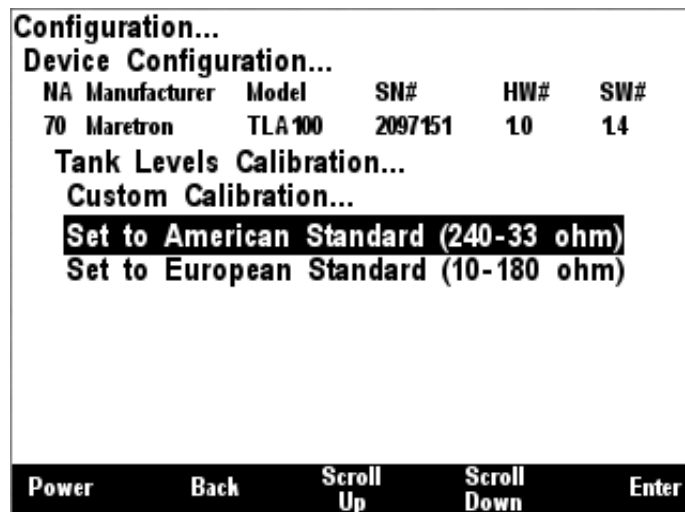




**Figure 127 – Custom Tank Level Calibration Confirmation Screen**

### 6.15.4.2 American Standard Sender Calibration

If you have a rectangular tank, and a sender with the standard American resistance range (240 ohms full, 33 ohms empty), and you know the capacity of the tank, you can easily calibrate the sender by using the “Set to American Standard (240-33 ohm)” menu item. Figure 128 below shows this option highlighted. Use the Scroll Up (↑) or Scroll Down (↓) keys to move the highlight over this menu item, and then press the Enter key (↵) to write the calibration values within the TLA100 and complete the calibration process.



**Figure 128 – American Standard Sender Calibration**

### 6.15.4.3 European Standard Sender Calibration

If you have a rectangular tank, and a sender with the standard European resistance range (0 ohms full, 180 ohms empty), and you know the capacity of the tank, you can easily calibrate the sender by using the “Set to European Standard (0-180 ohm)” menu item. Figure 129 below shows this option highlighted. Use the Scroll Up (↑) or Scroll Down (↓) keys to move the highlight over this menu item, and then press the Enter key (↵) to store the calibration values within the TLA100 and complete the calibration process.

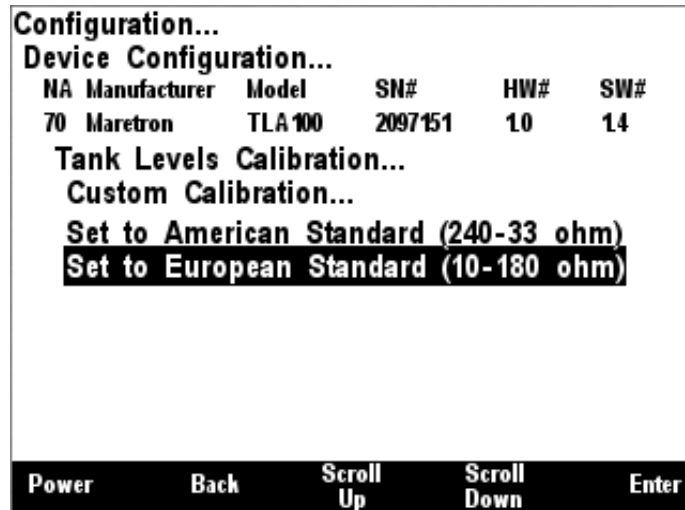


Figure 129 – European Standard Sender Calibration

## 6.15.5 Tank Number

Next, the tank number must be configured. A tank number can have a value between 0 and 15. Each tank of a particular type must have a tank number that is different from all other tanks of the same type. For instance, only one TLA100 on a fuel tank may have tank number equal to “0”. A screenshot of tank number configuration is shown in Figure 130 below. In order to configure the tank number, use the Scroll Up (↑) or Scroll Down (↓) keys to move the highlighted cursor to “Tank Number:”, then press the Enter key (↵) to move the cursor over to the tank number value. Use the Scroll Up (↑) or Scroll Down (↓) keys to select the desired tank number. Finally, press the Enter key (↵) to confirm your selection and store the new tank number within the TLA100.

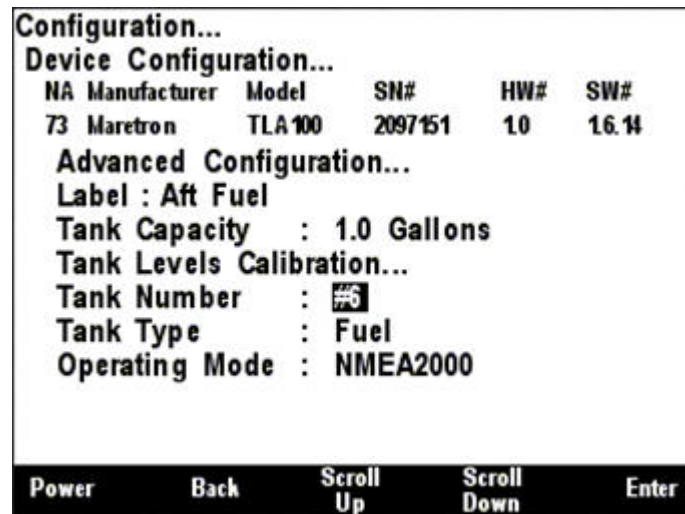


Figure 130 – Configuring the Tank Number

## 6.15.6 Tank Type

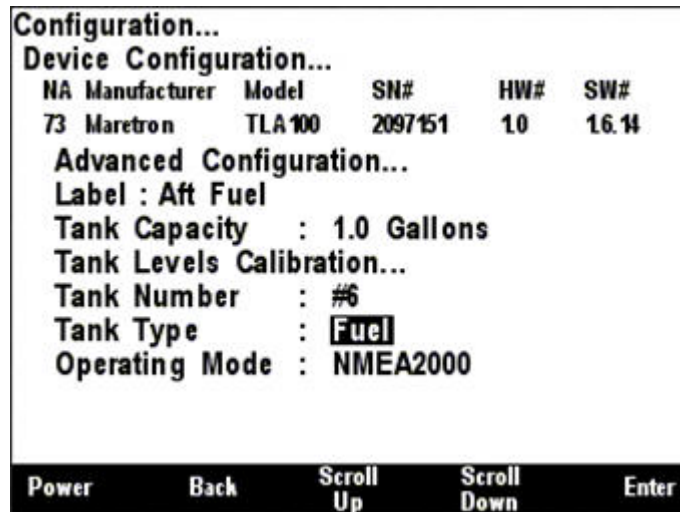
The TLA100 can be used in tanks containing any of a number of different types of fluids. So that network-connected monitoring devices can determine easily what sort of fluid is in the monitored tank, the TLA100 must be programmed to indicate the fluid type it is monitoring. Figure 131 below shows a screen shot of the tank type being configured. First, use the Scroll Up (↑) or Scroll Down (↓)

keys to position the highlighted cursor over “Tank Type:”, then press the Enter key (↵) to move the highlight to the tank type data itself. Now, use the Scroll Up (↑) or Scroll Down (↓) keys to change the tank type data to the type desired. Finally, press the Enter key (↵) to confirm the selection and store the value within the TLA100.

Available tank types are as follows:

- Fuel
- Fresh Water
- Waste Water
- Live Well
- Oil
- Black Water

There are also a number of reserved tank types to accommodate possible future undefined tank types.



*Figure 131 – Configuring the Tank Type*

## 6.15.7 Operating Mode

The TLA100 can be operated in one of two operating modes, depending on the installation.

- **NMEA 2000** (the only thing that is connected to the resistive sender is the TLA100)
- **NMEA 2000 & Analog Gauge** (in addition to the TLA100, the resistive sender is also connected to a dual-coil analog gauge).

It is important that this setting be performed correctly in order for the TLA100 to produce correct level measurements. A screenshot showing configuration of the operating mode appears in Figure 132 below. To configure the operating mode, use the Scroll Up (↑) or Scroll Down (↓) keys to move the highlighted cursor over the “Operating Mode:” menu item, then press the Enter key (↵) to move the highlight over the operating mode value. Use the Scroll Up (↑) or Scroll Down (↓) keys to change the operating mode to the desired value, and finally, press the Entry key to confirm your selection and store the operating mode within the TLA100.

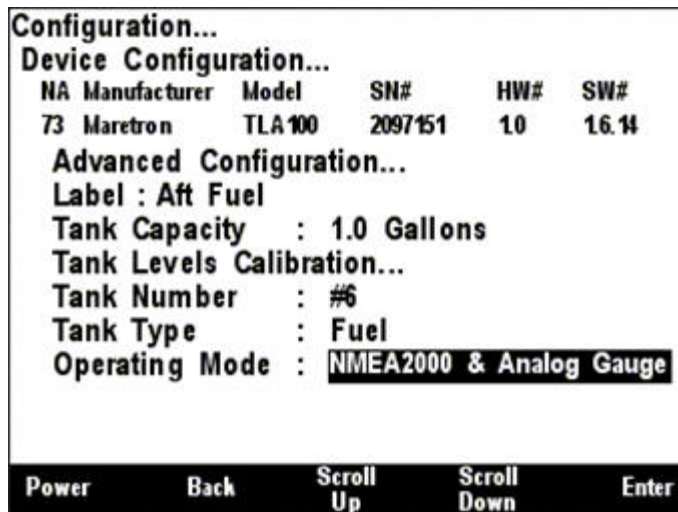


Figure 132 – Configuring the Operating Mode

## 6.15.8 Gauge Resistance, + to Sender

If the desired operating mode is “NMEA 2000 & Analog Gauge”, the two gauge resistances must be programmed (please refer to the *TLA100 User's Manual* for details on how to perform these measurements). A screenshot of the + to sender gauge resistance configuration is shown in Figure 133 below. To program the + to sender gauge resistance, use the Scroll Up (↑) or Scroll Down (↓) keys to move the highlighted cursor over the “Gauge Resistance, + to Sender:” menu item. Then, press the Enter key (↵) to move the highlight over the numerical resistance value. Use the “Increase” and “Decrease” keys to change the value to the measured resistance value, and finally, press the Enter key (↵) to confirm your selection and store the value within the TLA100.

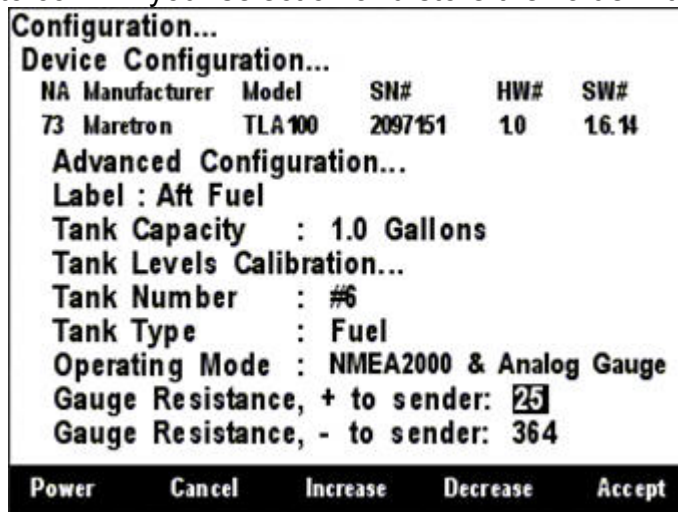
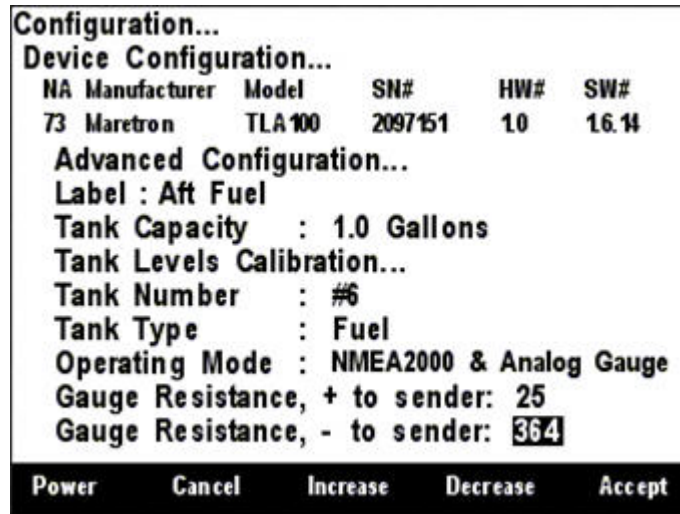


Figure 133 – Configuring the + to Sender Gauge Resistance

## 6.15.9 Gauge Resistance, - to Sender

If the desired operating mode is “NMEA 2000 & Analog Gauge”, the two gauge resistances must be programmed (please refer to the *TLA100 User's Manual* for details on how to perform these measurements). A screenshot of the - to sender gauge resistance configuration is shown in Figure 134 below.

To program the - to sender gauge resistance, use the Scroll Up (↑) or Scroll Down (↓) keys to move the highlighted cursor over the “Gauge Resistance, - to Sender:” menu item. Then, press the Enter key (↵) to move the highlight over the numerical resistance value. Use the “Increase” and “Decrease” keys to change the value to the measured resistance value, and finally, press the Enter key (↵) to confirm your selection and store the value within the TLA100.



*Figure 134 – Configuring the - to Sender Gauge Resistance*

## 6.16 Maretron TLM100 Configuration

The DSM250 may be used to configure and calibrate the Tank Level Monitor (TLM100 / TLM150 / TLM200). This describes the configuration of firmware version 1.1.4. After selecting the TLM100 from the list of devices on the network, the following screen will be displayed.

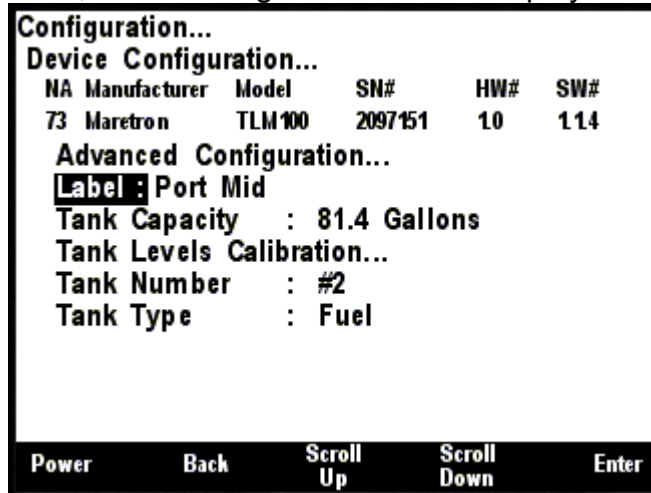


Figure 135 – TLM100 Configuration Screen

### 6.16.1 Advanced Configuration

Advanced Configuration changes some complex parameters within the device, and should only be performed by an advanced user. Typically advanced configuration is only done at installation and should not need to be done while at sea.

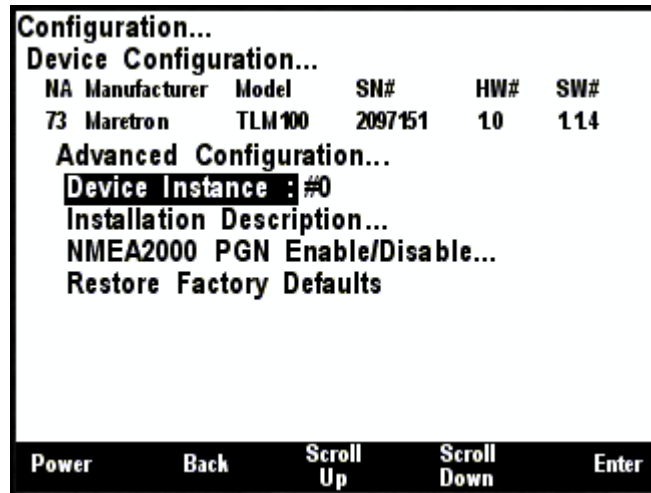


Figure 136 – TLM100 Advanced Configuration Screen

#### 6.16.1.1 Device Instance

This entry allows you to program the NMEA 2000 device instance for the unit. You usually will not need to modify the default value of “0” unless you have multiple units on the network.

#### 6.16.1.2 Installation Description

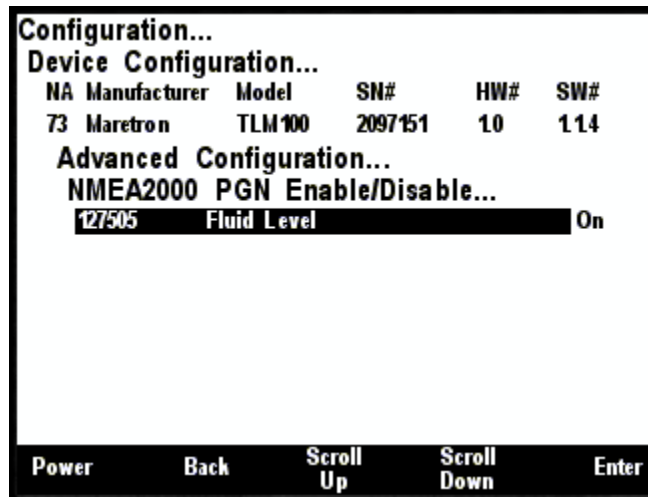
This entry allows you to modify the NMEA 2000 installation description text strings. You can enter any information you like here, such as the date the unit was installed, or the location in which it was



installed, for later reference. Tools such as Maretron N2KAnalyzer allow you to view these values later.

### 6.16.1.3 NMEA2000 PGN Enable/Disable

The TLM100 Tank Level Module transmits the NMEA2000 PGN #127505 which can be turned on or turned off by the DSM250 display. Pressing the **Enter** key with “NMEA2000 PGN Enable/Disable...” menu item selected causes the DSM250 to display the following screen.



**Figure 137 – TLM100 NMEA 2000® PGN Enable/Disable Screen**

You can enable or disable the transmission of the Binary Switch Status message by pressing the Enter key (⏎) on the message to be configured. Options are:

**Off** – The fluid level message will not be transmitted

**On** – The fluid level message will be transmitted at its default NMEA2000 rate, which is once every 2.5 seconds.

Select the required option using the **Scroll Up** and **Scroll Down** keys followed by the **Enter** key.

### 6.16.1.4 Restore Factory Defaults

This option restores all settings on the device to their factory default state.

### 6.16.2 Label

A label may be assigned to the TLM100 as an aid to identifying the device over the network. Typically this label will describe the location of the TLM100, and a description of the contents of the tank.

### 6.16.3 Tank Capacity

In order for the TLM100 to produce readings of the amount of fluid remaining in the tank, the tank capacity must be programmed into the TLM100 adapter. Figure 138 below shows a screen shot of the tank capacity being configured. To program the tank capacity, use the **Scroll Up** or **Scroll Down** keys to move the highlighted cursor over the “Tank Capacity:” menu item. Then, press the **Enter** key to move the highlight over the numerical tank capacity value. Use the **Increase** and **Decrease** keys to

# DSM250 User's Manual

change the value to the desired tank capacity value, and finally, press the **Accept** key to confirm your selection.

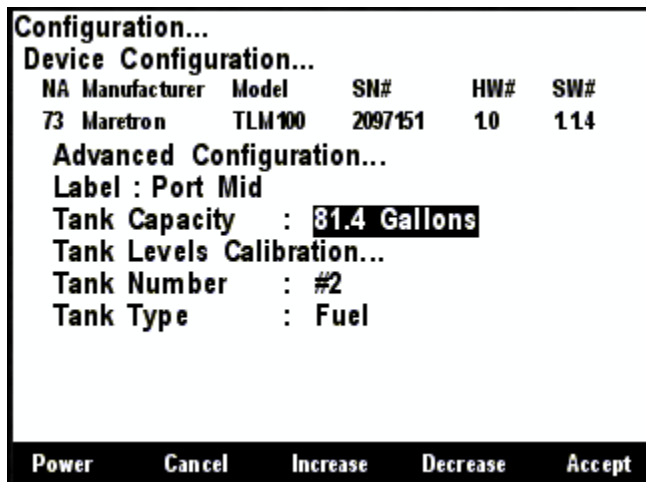


Figure 138 – Configuring the Tank Capacity

After you have pressed the **Accept** key, a confirmation screen will appear that warns you that the fluid remaining measurement will change as a result of this change. Press the **Accept** key to accept the change and store the new tank capacity value within the TLM100, or Press the **Cancel** Key to cancel the change and leave the old tank capacity programmed into the TLM100.

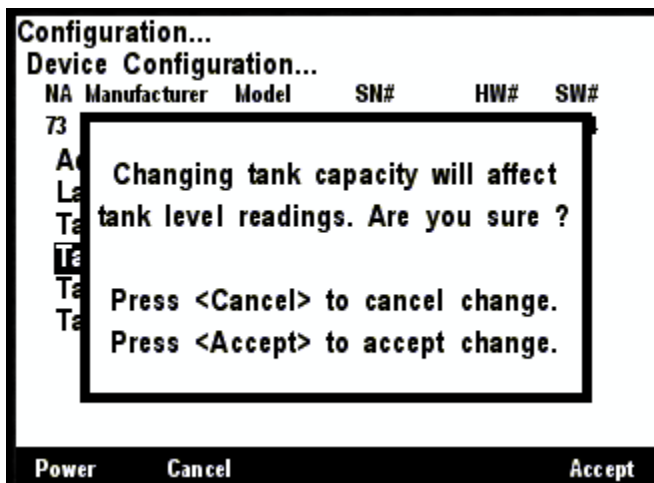


Figure 139 – Tank Capacity Change Confirmation Screen

## 6.16.4 Tank Levels Calibration

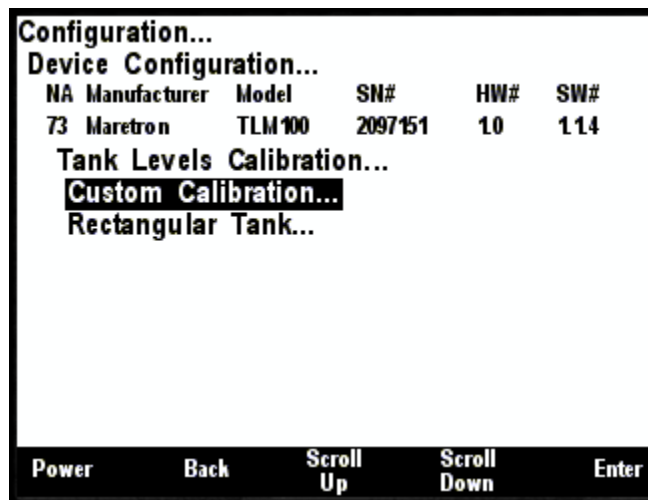
In order for the TLM100 to indicate an accurate tank level, it must know the geometry of the tank. There are two methods of calibrating the tank level sender:

- Custom Calibration – use for non-rectangular tanks (also, most accurate in any case, but requires more effort)
- Rectangular Tank – By inputting some dimensions of a rectangular tank, the TLM100 is able to interpolate the volume of liquid from the distance to the surface.



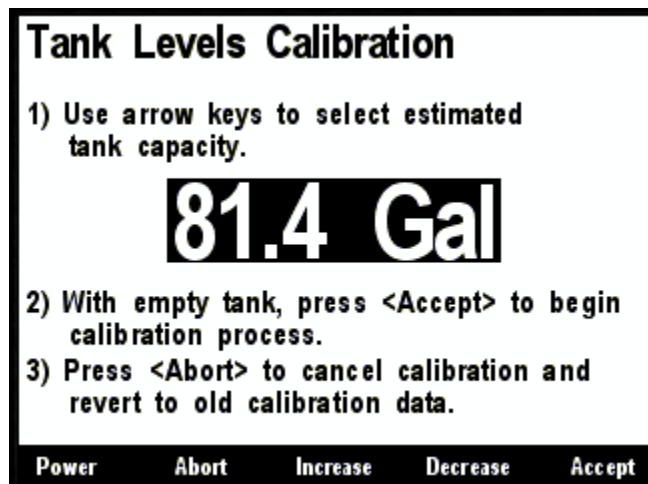
## 6.16.4.1 Custom Calibration

The Custom Calibration setting will provide the most accurate tank level readings under any circumstances, but it requires that you go through a process in which you gradually fill the tank, stopping periodically to input the current fluid level. The TLM100 will measure the distance to the surface at each point and create a custom calibration map which relates the fluid levels to the volume in the tank. Figure 122 below shows a screenshot of the DSM250 with the Custom Calibration option highlighted. Custom calibration is necessary for non-rectangular tanks. To perform custom calibration of the tank level sender, use the Scroll Up (↑) or Scroll Down (↓) keys to move the highlighted cursor over the “Custom Calibration...” menu item. Then, press the Enter key (↵) to confirm your selection and begin the calibration process.



**Figure 140 – Performing Custom Calibration of the Tank Level Monitor**

The first step in custom calibration of the tank level monitor is to provide an estimated capacity of the tank. This estimated capacity must be within +/- 25% of the actual capacity. To set the estimated tank capacity, use the **Increase** and **Decrease** keys to adjust the displayed value until the desired value is shown. Then, press the **Accept** key to confirm your selection and continue with the calibration process. If you desire to stop the calibration process, pressing the **Abort** key (⊗) will end the process and return you to the Tank Levels Calibration menu.

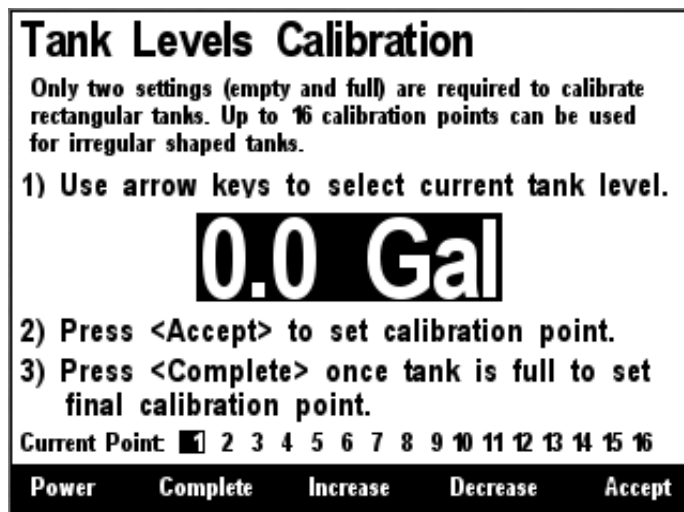


**Figure 141 – Tank Levels Calibration Capacity Estimation**

# DSM250 User's Manual

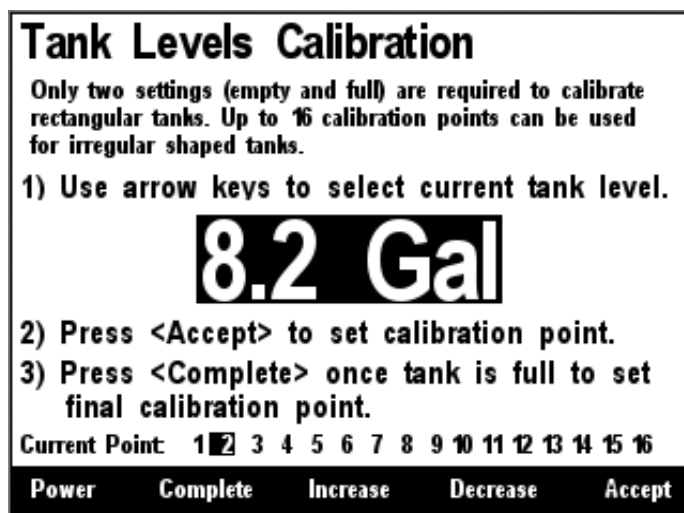
---

The next step in the calibration process is to fill the tank and indicate the volume of fluid in the tank at various points while filling the tank. This process should be started with an empty tank. You only need to indicate two calibration points for a rectangular tank, and can use up to 16 calibration points for a tank with a more complex shape. Figure 142 shows a screenshot of the first calibration step. Enter the first calibration point with an empty tank (0.0 Gallons/liters) by pressing the **Accept** key. The "Current Point" highlight will advance to the next point.



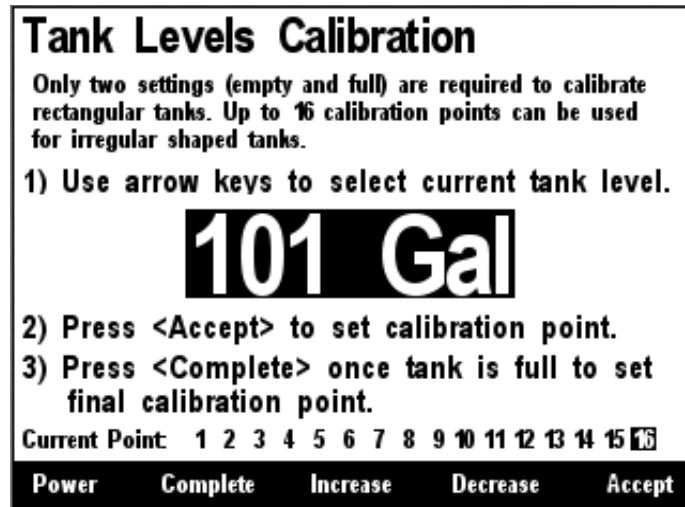
*Figure 142 – Empty Level Calibration*

Each time you press **Accept** during this process and after the Current Point highlight advances, put more fluid into the tank, and note the total volume of fluid pumped into the tank at this point. Use the **Increase** and **Decrease** keys to set the current tank level to the appropriate value, and then press the **Accept** key to store the current calibration point and advance to the next calibration point. Figure 143 shows a screenshot of these intermediate calibration points.



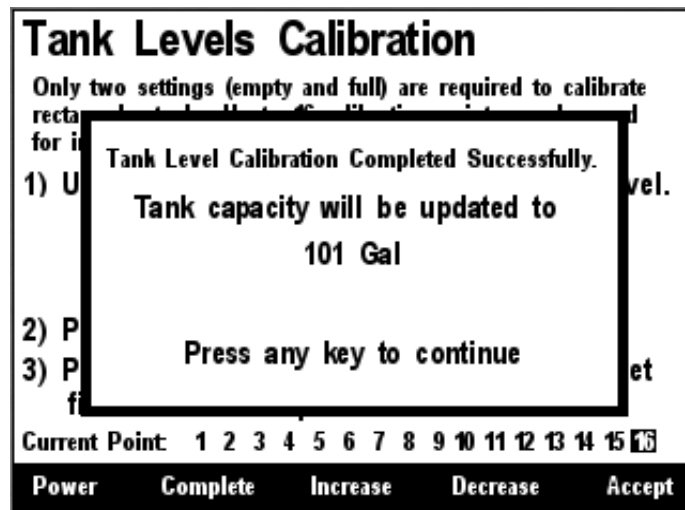
*Figure 143 – Intermediate Level Calibration*

Once the tank is completely full, instead of pressing the **Accept** key to store the current calibration point, press the **Complete** key. This will complete the calibration process and will also adjust the tank capacity to the currently indicated level. Figure 144 below shows the calibration screen at the last point with the full tank level (and thus the tank capacity) set to 101 gallons.



*Figure 144 – Full Level Calibration*

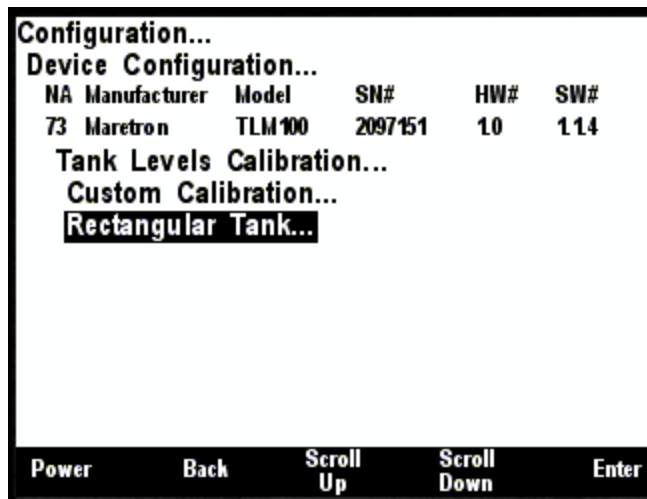
After you press accept, a confirmation screen will appear showing completion of the calibration process and the new tank capacity value. A screenshot of this calibration screen is shown below in Figure 145.



*Figure 145 – Custom Tank Level Calibration Confirmation Screen*

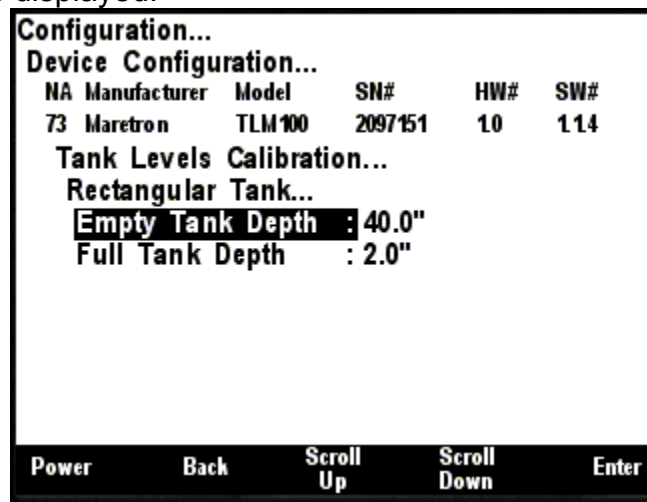
### 6.16.4.2 Rectangular Tank

If you have a rectangular tank, and you know the capacity of the tank, you can easily calibrate the sender by using the “Rectangular Tank” menu item. Figure 146 below shows this option highlighted. Use the Scroll Up (↑) or Scroll Down (↓) keys to move the highlight over this menu item, and then press the Enter key (↵).



*Figure 146 – Rectangular Tank Selection*

The following screen will be displayed.



*Figure 147- Rectangular Tank Calibration*

Enter the distance from the face of the TLM100 sensor to the bottom of the tank for the **Empty Tank Depth**, and the distance from the face of the TLM100 sensor to the top of the liquid when the tank is full for the **Full Tank Depth**.

After entering the values, use the **Back** button to return the parent menu.

## 6.16.5 Tank Number

The Tank Number is the Data Instance used in the data message. This can be set from #0 to #15.

## 6.16.6 Tank Type

This is set to the type of fluid in the tank. Values are:

- Fuel -
- Fresh Water -
- Waste Water -

**Live Well -**

**Oil -**

**Black Water -**

**Reserved-1..Reserved-7** – These values may be used when the contents of the tank does not fit into one of the categories above.

## 6.17 Maretron TLM150 Configuration

The TLM150 is the gasoline version of the TLM100. The configuration of the two devices is the same; see section 0 for details.

## 6.18 Maretron TLM200 Configuration

The TLM200 is the deep tank version of the TLM100. The configuration of the two devices is the same; see section 0 for details.

## 6.19 Maretron TMP100 Configuration

Maretron Temperature Modules (TMP100) may be configured using the DSM250. This describes the configuration of the Maretron TMP100 firmware version 1.1.1. The top level of the TMP100 configuration menu is shown below.

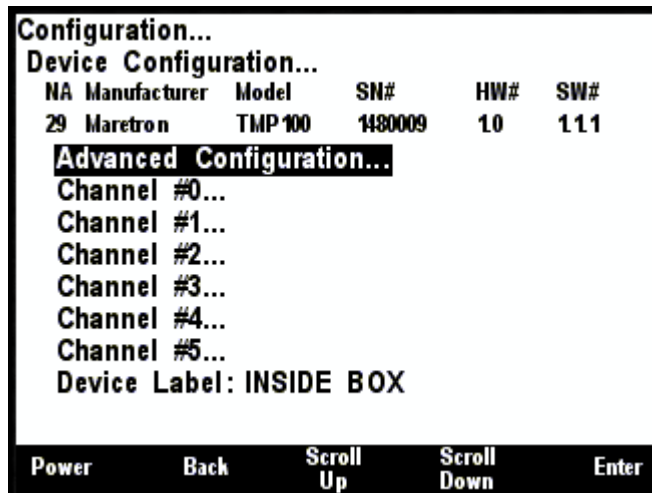


Figure 148 – TMP100 Configuration Screen

### 6.19.1 Advanced Configuration

Advanced Configuration changes some complex parameters within the device, and should only be performed by an advanced user. Typically advanced configuration is only done at installation and should not need to be done while at sea.

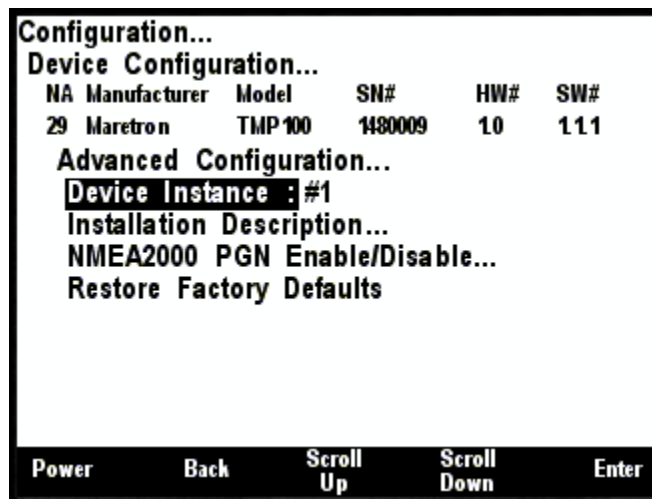


Figure 149 – TMP100 Advanced Configuration Screen

#### 6.19.1.1 Device Instance

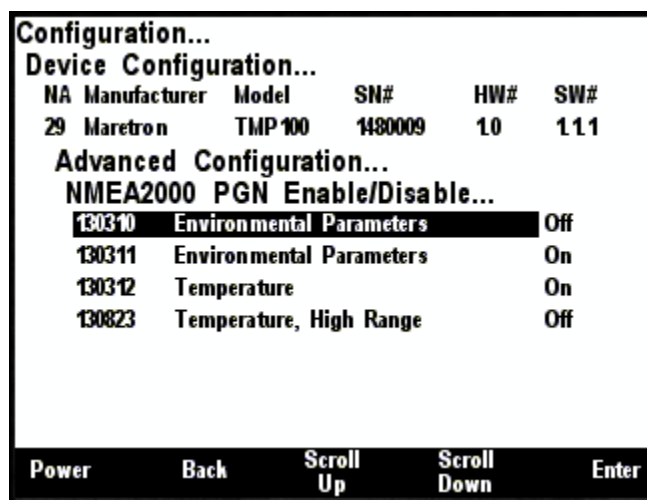
This entry allows you to program the NMEA 2000 device instance for the unit. You usually will not need to modify the default value of “0” unless you have multiple units on the network.

## 6.19.1.2 Installation Description

This entry allows you to modify the NMEA 2000 installation description text strings. You can enter any information you like here, such as the date the unit was installed, or the location in which it was installed, for later reference. Tools such as Maretron N2KAnalyzer allow you to view these values later.

## 6.19.1.3 NMEA2000 PGN Enable/Disable

The TMP100 Temperature Module transmits a number of the NMEA2000® PGNs which can be turned on or turned off by the DSM250 display. For reasons of compatibility with older NMEA2000 devices, some of these PGNs are redundant; disabling these PGNs will reduce the amount of traffic on the NMEA2000® bus. Pressing the **Enter** key with “NMEA2000 PGN Enable/Disable...” menu item selected causes the DSM250 to display the following screen.



*Figure 150 – TMP100 NMEA 2000® PGN Enable/Disable Screen*

You can enable or disable the transmission of a PGN message, or set the frequency of transmission of the message by pressing the Enter key (⏎) on the message to be configured. Options are:

- Off** – The PGN will not be transmitted
- On** – The PGN will be transmitted at its default NMEA2000 rate.
- 0.5s...5s** – The PGN will be transmitted at the interval specified.

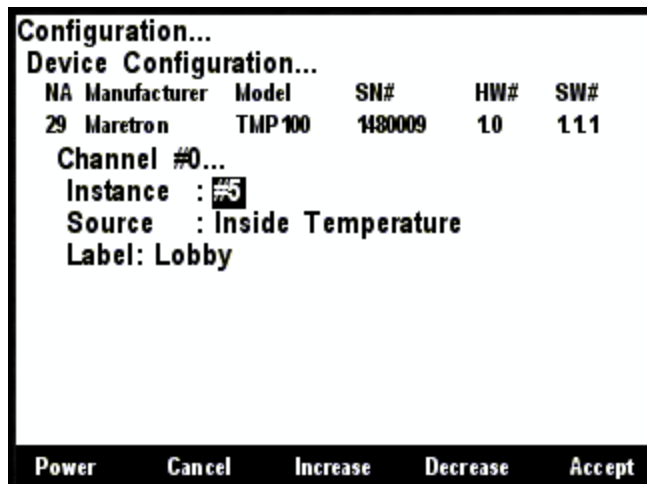
Select the required option using the **Scroll Up** and **Scroll Down** keys followed by the **Enter** key.

## 6.19.1.4 Restore Factory Defaults

This option restores all settings on the device to their factory default state.

## 6.19.2 Channel Configuration

Individual channels may be configured by using the **Scroll Up** and **Scroll Down** buttons to highlight the channel, and then pressing the **Enter** key. The following screen will be displayed.



**Figure 151 – TMP100 Channel Configuration Screen**

### 6.19.2.1 Instance

The Data Instance of the Temperature (as sent in PGNs 130311, 130312, and 130823) is set in this field. Use the **Increase** and **Decrease** buttons to select the correct instance number, and then press the **Enter** button to store it.

### 6.19.2.2 Source

In the NMEA2000® PGNs, each temperature is associated with a source type. Possible values are:

- Bait Well Temperature
- Engine Room Temperature
- Exhaust Gas Temperature
- Freezer Temperature
- Heating System Temperature
- Inside Temperature
- Live Well Temperature
- Main Cabin Temperature
- Outside Temperature
- Refrigeration Temperature
- Sea Temperature
- User Defined Temperature #129...#144 – Use this when none of the above options are suitable.

Use the **Scroll Up** and **Scroll Down** buttons to select the correct source, and then press the **Enter** button to store it.

### 6.19.2.3 Label

A label may be assigned to each channel of the TMP100 as an aid to identifying the temperature that is being displayed. Typically this label will describe the function or location of the temperature sensor.

### 6.19.3 Device Label

A label may be assigned to the TMP100 as an aid to identifying the device over the network. Typically this label will describe the location of the TMP100.



## 6.20 Maretron USB100 Configuration

Maretron USB100 gateways on the network may be configured using the DSM250. This describes the configuration of the Maretron USB100 firmware version 1.8.2. The USB100 configuration menu is shown in Figure 152 below. There is one configurable item for the USB100 and that is “Remote Device Selection...”.

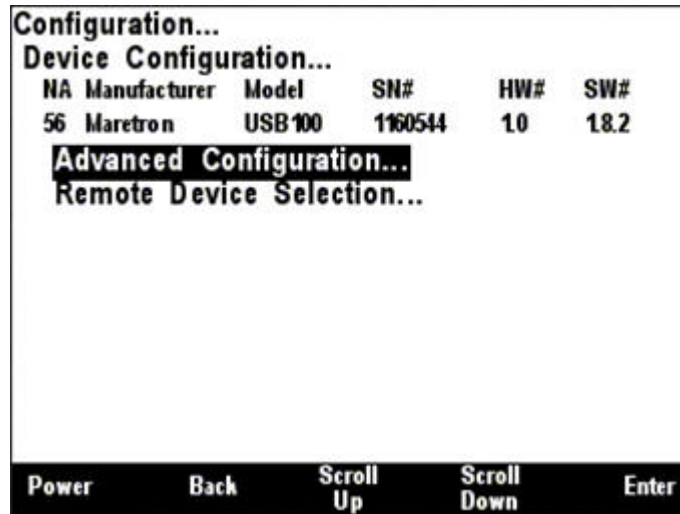


Figure 152 – USB100 Configuration Screen

### 6.20.1 Advanced Configuration

Advanced Configuration changes some complex parameters within the device, and should only be performed by an advanced user. Typically advanced configuration is only done at installation and should not need to be done while at sea.

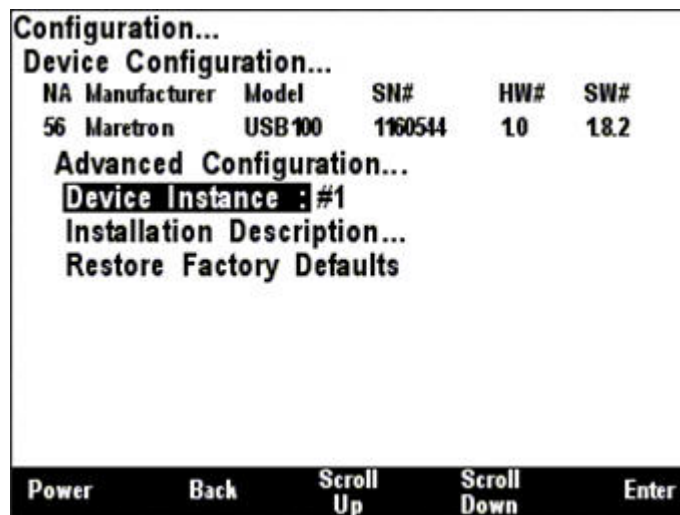


Figure 153 – USB100 Advanced Configuration Screen

#### 6.20.1.1 Device Instance

This entry allows you to program the NMEA 2000 device instance for the unit. You usually will not need to modify the default value of “0” unless you have multiple units on the network.

# DSM250 User's Manual

## 6.20.1.2 Installation Description

This entry allows you to modify the NMEA 2000 installation description text strings. You can enter any information you like here, such as the date the unit was installed, or the location in which it was installed, for later reference. Tools such as Maretron N2KAnalyzer allow you to view these values later.

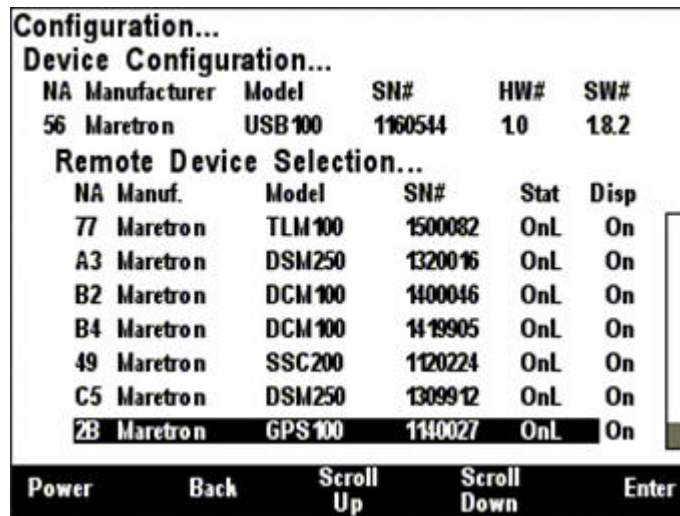
## 6.20.1.3 Restore Factory Defaults

This option restores all settings on the device to their factory default state.

## 6.20.2 Remote Device Selection

The Maretron NMEA 2000<sup>®</sup> to NMEA 0183 gateway (USB100) can be configured to select which NMEA 2000<sup>®</sup> devices are selected for display on the computer attached to the USB interface of the USB100. In this manner, multiple devices of the same type may be used on a NMEA 2000<sup>®</sup> network in a fail-safe configuration. The USB100 Device Selection Menu for an example network configuration can be seen in Figure 154.

**WARNING:** Do not select multiple devices of the same type for display. This will result in multiple and possibly conflicting readings.



The screenshot shows a terminal window with the following content:

```
Configuration...
Device Configuration...
NA Manufacturer Model SN# HW# SW#
56 Maretron USB100 1160544 10 18.2

Remote Device Selection...
NA Manuf. Model SN# Stat Disp
77 Maretron TLM100 1500082 OnL On
A3 Maretron DSM250 1320016 OnL On
B2 Maretron DCM100 1400046 OnL On
B4 Maretron DCM100 1419905 OnL On
49 Maretron SSC200 1120224 OnL On
C5 Maretron DSM250 1309912 OnL On
2B Maretron GPS100 1140027 OnL On
```

At the bottom of the screen, there are five buttons: Power, Back, Scroll Up, Scroll Down, and Enter.

Figure 154 – USB100 Device Selection Screen

The “NA” column of the menu displays the node address the device is using.

The “Manuf.” column of the menu displays the manufacturer of the device.

The “Model” column displays the model number of the device.

The “SN#” column displays the serial number of the device, so that any of two or more devices of the same manufacturer and model number may be distinguished from one another.

The “Stat” column indicates whether the device is currently connected to the bus and is responding to queries (“Online”), or has been disconnected from the bus, has lost power, or for some other reason is not responding to queries (“Offline”).

The “Disp” column indicates whether data from that particular device is accepted for display by the USB100 (“On”) or that the USB100 ignores data transmitted by this device (“Off”). By scrolling to the device and pressing the Enter key (↵), you may then use the Scroll Up (⬆) and Scroll Down (⬇) keys to toggle the “Display” status for this particular device. Once you

are satisfied with the state of the “Display” setting, press the Enter key (⏎) to accept the setting. The USB100 will retain information on devices that have been removed from the bus or powered down (“Offline”) so that when they are placed back on the bus, they will assume their prior “Display” setting.

# DSM250 User's Manual

## 6.21 Maretron WSO100 Configuration

The DSM250 is capable of performing configuration of the WSO100 Wind/Weather Sensor. This describes the configuration of the Maretron WSO100 firmware version 2.0.12. Figure 155 below shows a screenshot of the WSO100 configuration menu.

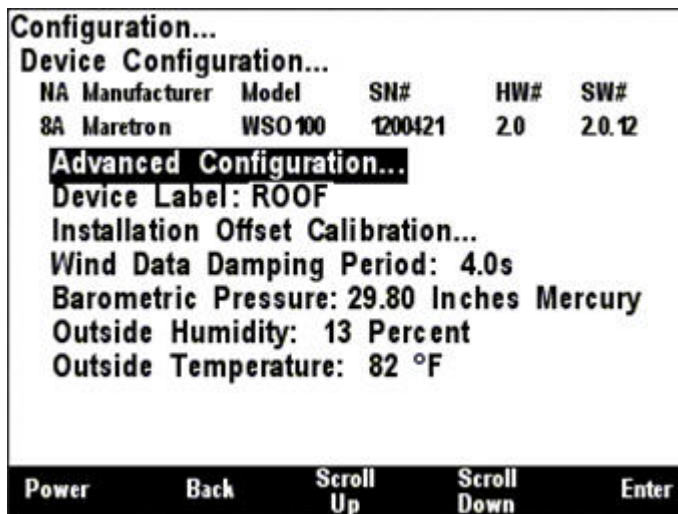


Figure 155 – WSO100 Configuration Screen

### 6.21.1 Advanced Configuration

Advanced Configuration changes some complex parameters within the device, and should only be performed by an advanced user. Typically advanced configuration is only done at installation and should not need to be done while at sea.

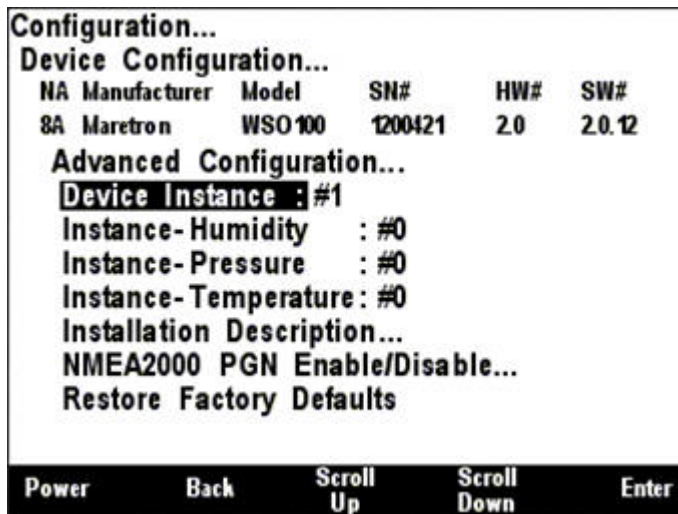


Figure 156 – WSO100 Advanced Configuration Screen

#### 6.21.1.1 Device Instance

This entry allows you to program the NMEA 2000 device instance for the unit. You usually will not need to modify the default value of "0" unless you have multiple units on the network. Device instance is always used in the Wind PGNs.

## 6.21.1.2 Instance - Humidity

This entry allows you to program the NMEA 2000 device instance for the humidity transmitted in PGN 130313. You usually will not need to modify the default value of “0” unless you have multiple humidity sensors on the network.

## 6.21.1.3 Instance - Pressure

This entry allows you to program the NMEA 2000 device instance for the air pressure transmitted in PGN 130314. You usually will not need to modify the default value of “0” unless you have multiple pressure sensors on the network.

## 6.21.1.4 Instance - Temperature

This entry allows you to program the NMEA 2000 device instance for the temperature transmitted in PGN 130312. You usually will not need to modify the default value of “0” unless you have multiple temperature sensors on the network. Note that the TMP100 module also generates these PGNs.

## 6.21.1.5 Installation Description

This entry allows you to modify the NMEA 2000 installation description text strings. You can enter any information you like here, such as the date the unit was installed, or the location in which it was installed, for later reference. Tools such as Maretron N2KAnalyzer allow you to view these values later.

## 6.21.1.6 NMEA2000 PGN Enable/Disable

The WSO100 Ultrasonic Wind and Weather Station transmits a number of NMEA2000 PGNs which can be turned on or turned off by the DSM250 display. For the vast majority of installations, the factory setting is appropriate, but if it becomes necessary to disable one of the transmitted messages from the WSO100, for instance, if you have a separate thermometer / humidity sensor / barometer on the network, it is possible to do so with the DSM250. Pressing the **Enter** key with “NMEA2000 PGN Enable/Disable...” menu item selected causes the DSM250 to display the following screen.

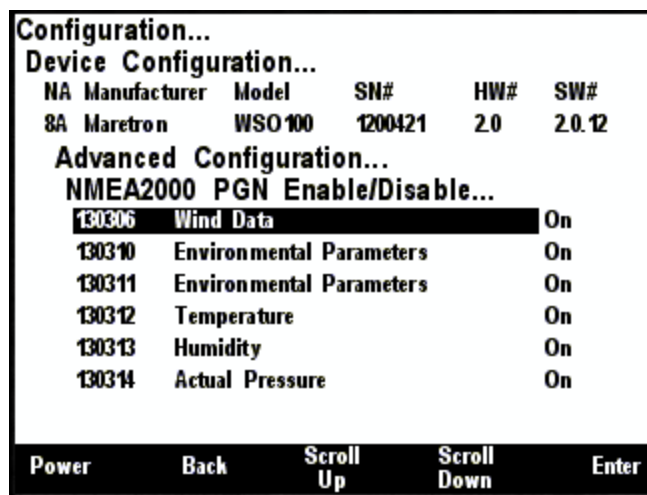


Figure 157 – WSO100 NMEA 2000® PGN Enable/Disable Screen

You can enable or disable the transmission of the messages by pressing the **Enter** key (⏎) on the message to be configured. Options are:

# DSM250 User's Manual

---

**Disable** – The message will not be transmitted

**Default** – The message will be transmitted at its default NMEA2000 rate.

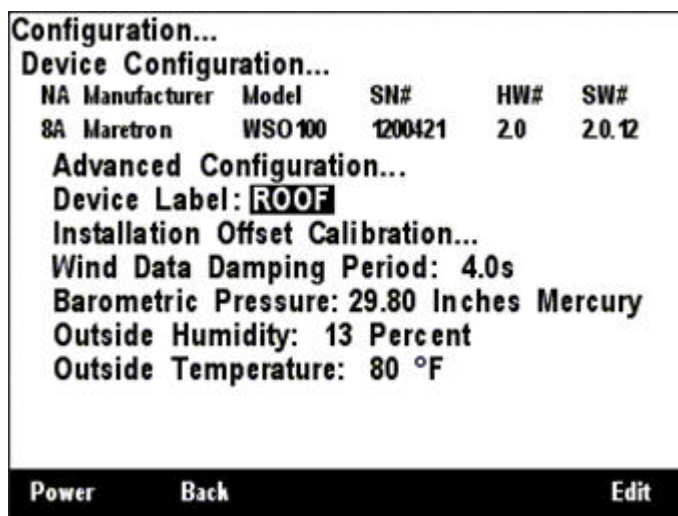
**0.5s...5.0s** – The message will be transmitted at the interval specified.

Select the required option using the **Scroll Up** and **Scroll Down** keys followed by the **Enter** key. Notice that by default, the old Environmental Parameters message (PGN 130310) is disabled while the new Environmental Parameters message (PGN 130311) is enabled. The reason for this is that the old message has been discontinued by the National Marine Electronics Association (NMEA) in favor of the new message. If you find that a particular display is not showing particular information (i.e., temperature, humidity, or barometric pressure), go ahead and enable the old message to see if data then becomes available.

## 6.21.1.7 Restore Factory Defaults

This option restores all settings on the device to their factory default state.

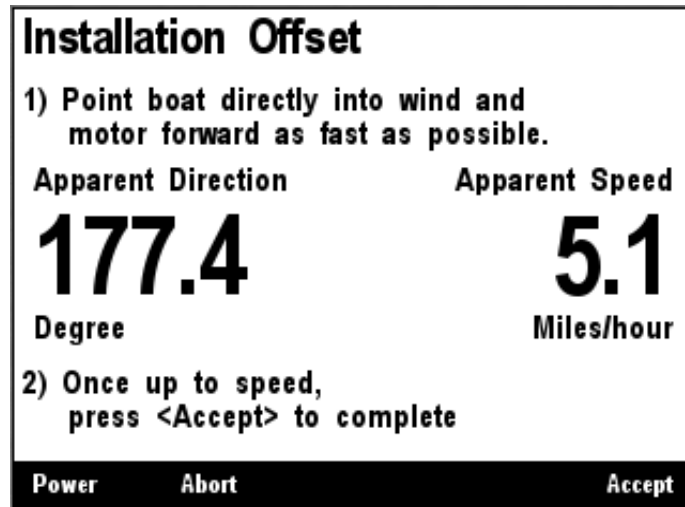
## 6.21.2 Device Label



## 6.21.3 Installation Offset Calibration

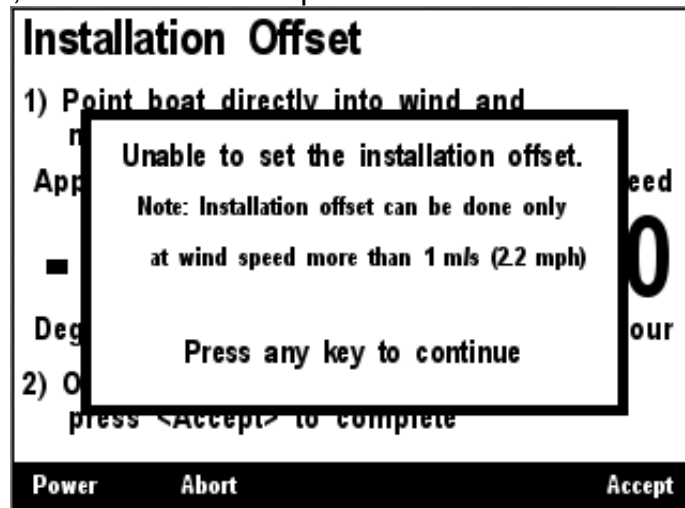
The WSO100 comes from the factory with a preset orientation, so that mounting it with the orientation marks facing the bow of the vessel, the sensor will read 0° apparent wind angle when the vessel is sailing directly into the wind (please refer to the *WSO100 User's Manual* for details).

However, the WSO100 can be installed in any orientation with respect to the vessel and any misalignment with respect to the factory preset can be easily compensated for using the Installation Offset calibration menu item. To perform installation offset calibration, use the Scroll Up (↑) or Scroll Down (↓) keys to move the highlighted cursor to the “Installation Offset Calibration...” menu item, and then press the Enter key (↵). The Installation Offset screen then appears, which is shown in Figure 158 below.



**Figure 158 – WSO100 Installation Offset Screen**

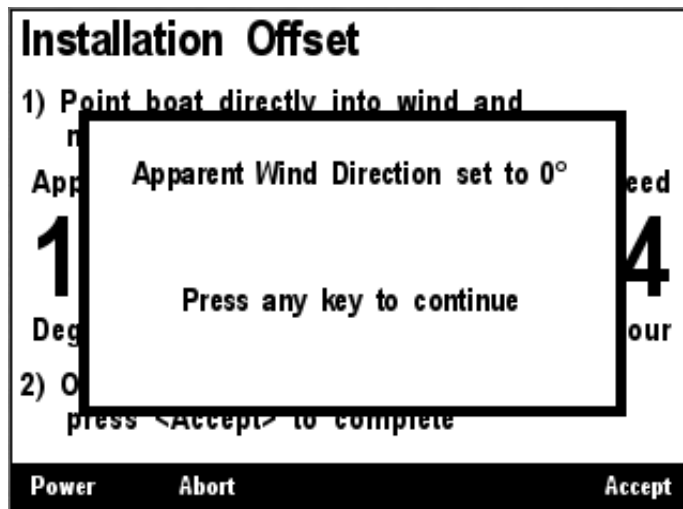
Turn the vessel directly into the wind and motor forward. When you are satisfied that the apparent wind is directly on the bow of the vessel, press the Accept key to set this angle to read 0° apparent wind on the WSO100. The WSO100 will only calibrate if the apparent wind speed is greater than 2.2 miles/hour. If the apparent wind speed is lower than this, then an error message will appear, which is shown in Figure 159 below, and the calibration process will be aborted.



**Figure 159 – WSO100 Configuration Aborted Due to Low Wind Speed**

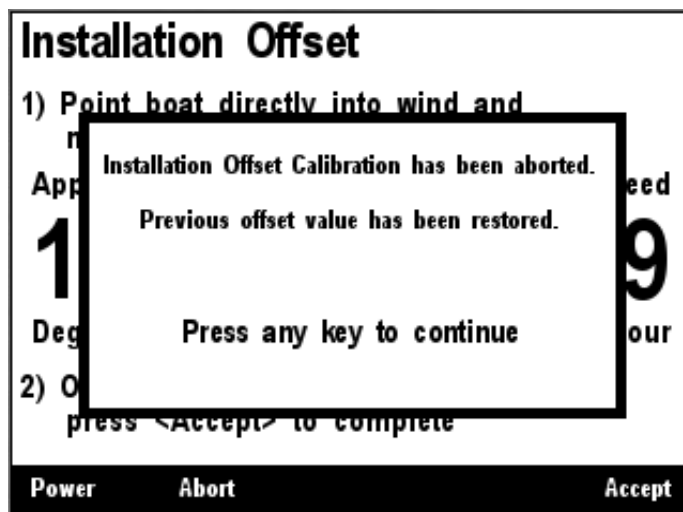
If the wind speed is sufficient, then a confirmation screen, shown in Figure 160 below, will appear, indicating that a successful installation offset calibration has completed.





*Figure 160 – Installation Offset Success Confirmation Screen*

You may instead abort calibration by pressing the Abort Key (⌫). If you do this, the installation offset calibration process will be aborted and a message will appear noting that this has happened, which appears in Figure 161 below.

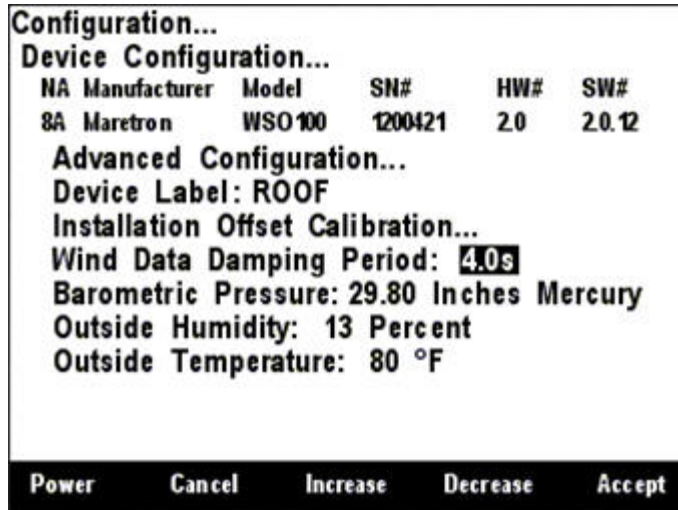


*Figure 161 – Installation Offset Abort Confirmation Screen*

## 6.21.4 Wind Data Damping Period

The WSO100 comes from the factory preset with a damping period of 1.5 seconds, which should be appropriate for most applications. However, you may use the DSM250 to tune the damping period to anywhere between 0.1 seconds and 5.0 seconds if you desire. To do this, use the Scroll Up (⬆) or Scroll Down (⬇) keys to move the highlighted cursor to the "Wind Data Damping Period:" menu item, then press the Enter key (⬅) to move the highlight to the numerical value on the right. This is shown in Figure 162 below. Use the Increase and Decrease keys to adjust the damping period to the desired value, and then press the Enter key (⬅) to accept the value and store it within the WSO100.

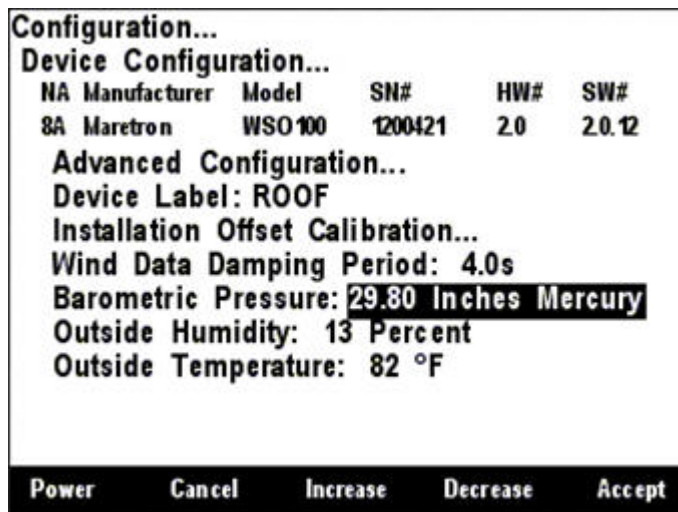




*Figure 162 – Setting the Wind Data Damping Period*

### 6.21.5 Barometric Pressure

The WSO100 has an internal barometer, which is pre-calibrated before leaving the factory. If the unit requires re-calibrating, then this field allows the entry of the actual pressure. This may be necessary if the vessel is on a lake with an altitude other than sea level, and the user wishes to normalize the barometric pressure to sea level.

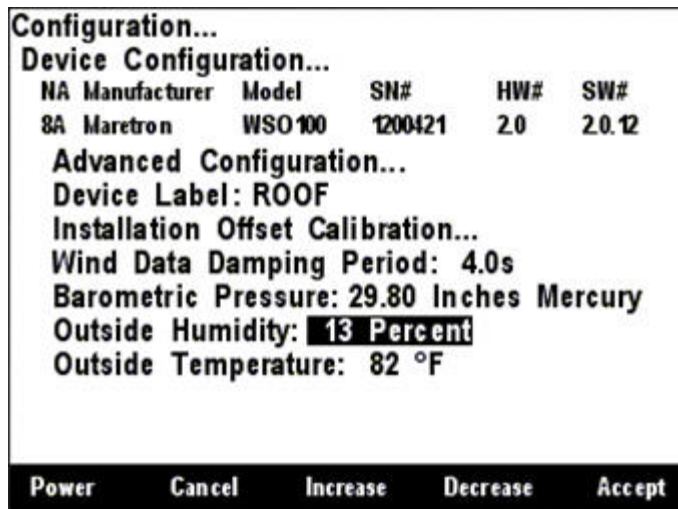


*Figure 163 – Setting the Barometric Pressure*

Use the **Increase** and **Decrease** buttons to select the correct pressure, and the press the **Enter** button to store it.

### 6.21.6 Outside Humidity

The Humidity is pre-calibrated before leaving the factory, and should not require adjustment. However the current humidity level may be entered in this screen to re-calibrate the WSO100 should this be required.

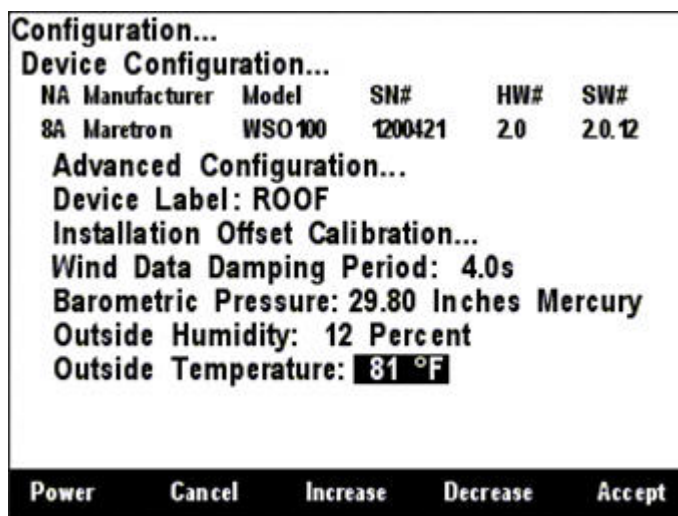


*Figure 164 – Setting the Outside Humidity*

Use the **Increase** and **Decrease** buttons to select the correct humidity, and the press the **Enter** button to store it.

## 6.21.7 Outside Temperature

The Temperature sensor is pre-calibrated before leaving the factory, and should not require adjustment. However the current temperature may be entered in this screen to re-calibrate the WSO100 should this be required.



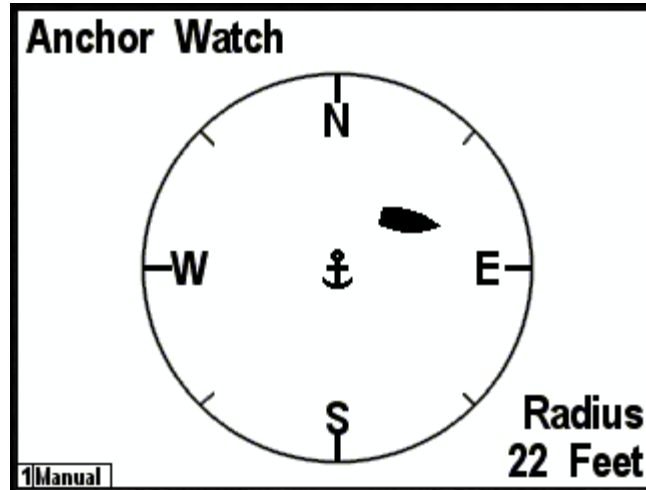
*Figure 165 – Setting the Outside Temperature*

Use the **Increase** and **Decrease** buttons to select the correct temperature, and the press the **Enter** button to store it.

## 7 Data Display Types

### 7.1 Anchor Watch Display

The Anchor Watch Display is a graphical representation of an Anchor Alert. See section 8.3.7.9 for details on how to set up the Anchor Alert.

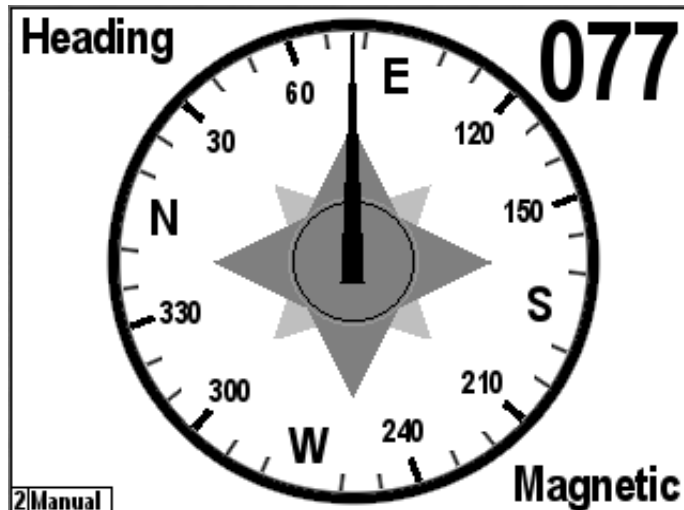


*Figure 166 – Anchor Watch Display Example*

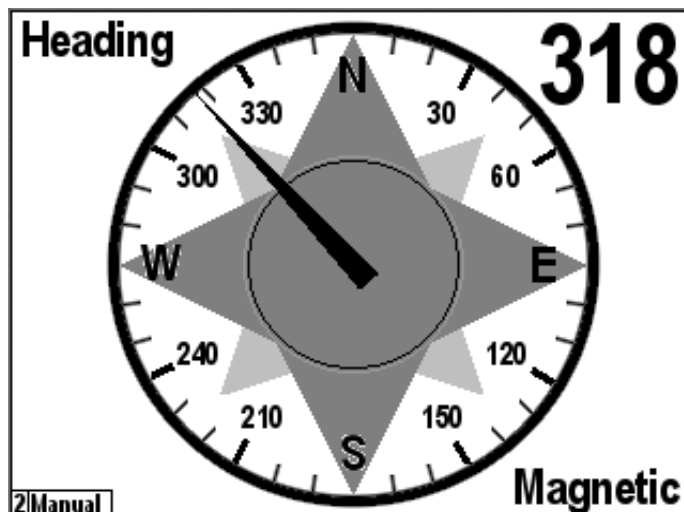
The display is centered on the position at which the anchor is dropped; this point is represented by the anchor symbol. The control is always oriented North-up, with the boundary circle located at the Alert Set Point distance from the anchor position. The position of the vessel is represented by the boat symbol. This is oriented according to the heading of the boat.

### 7.2 Compass Rose Display

The compass rose display shows a heading, bearing, or course parameter on a compass rose display. There are two types of compass roses, 1) "Course Up" where the needle is always pointing straight up and the compass rose rotates to indicate the heading pointed to by the needle (Figure 167), and 2) "North Up" where the rose always has North straight up and the needle rotates pointing in the direction of the heading, bearing or course parameter (Figure 168).



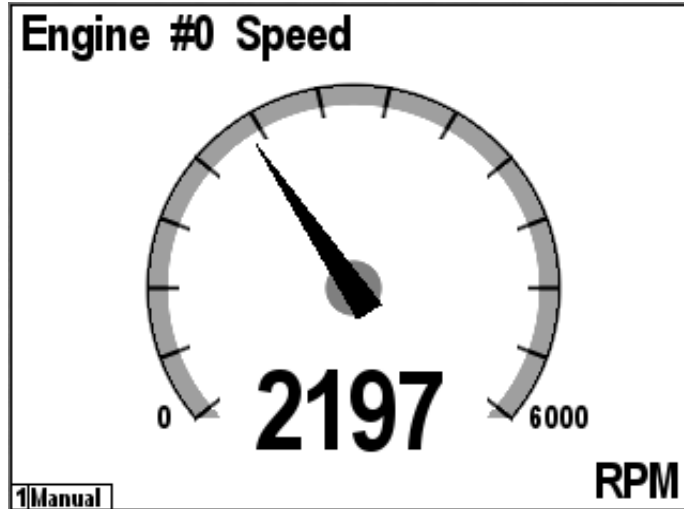
*Figure 167 – Compass Rose Display (Course Up) Example*



*Figure 168 – Compass Rose (North Up) Display*

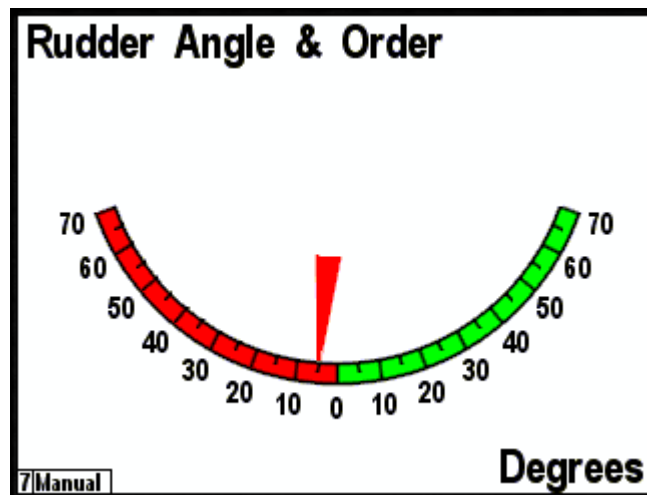
## 7.3 Gauge Display

The gauge display shows the selected data in a graphical format resembling an analog gauge. There is a general gauge format for most types of display, and a specialized rudder gauge display. A full-screen example of a tachometer display can be seen in Figure 169 below.



*Figure 169 – Gauge Display Example*

A full-screen example of the rudder gauge display can be seen in Figure 170 below.



*Figure 170 – Rudder Angle Gauge Display Example*

# DSM250 User's Manual

## 7.4 GPS Status Display

The GPS Status display shows the following data about the selected GPS receiver:

- GPS operating mode (2D, 3D, DGPS)
- Satellite signal strength (up to 12 satellites)
- Satellite azimuth and elevation (up to 12 satellites)
- Position
- HDOP
- Time
- Date
- Accuracy of position

An example of a full-screen GPS Status display can be seen below.

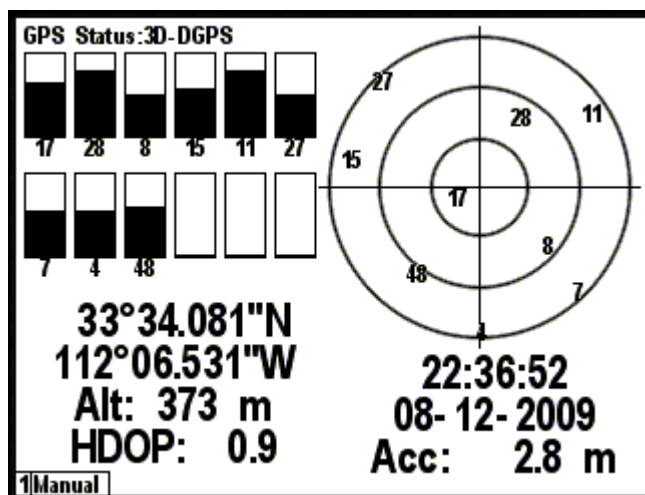
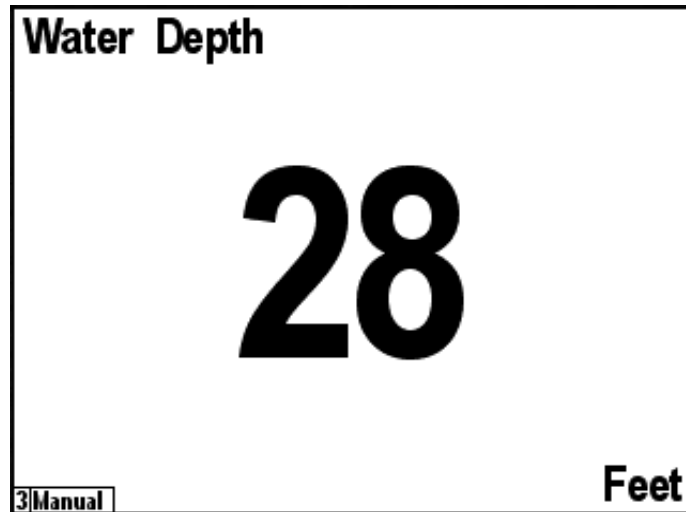


Figure 171 – GPS Status Display Example

## 7.5 Numeric Display

The numeric display shows the selected parameter in a numeric format on the screen. A full-screen example of the current depth display can be seen below.

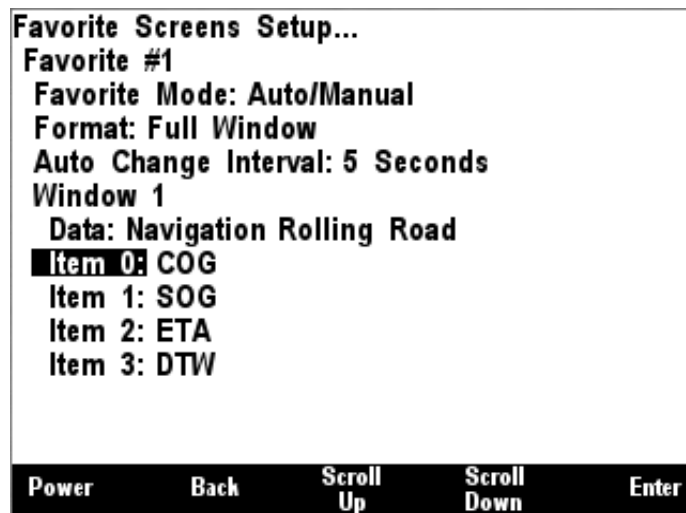


**Figure 172 – Numeric Display Example**

The upper left hand corner indicates the parameter being displayed and the center of the screen shows the numeric value for the indicated parameter. The bottom right hand corner shows the units.

## 7.6 Rolling Road

The DSM250 supports a “Rolling Road”, or navigation highway display. This display repeats transmitted navigation data from a primary navigator, such as a chart plotter or a personal computer running navigation software. Figure 173 below shows the favorites screen setup menu with the rolling road selected. When the rolling road is selected the displayed navigation data, the “Type:” submenu changes to four “Item:” submenus. The rolling road display can show numerical displays of four navigation-related data items in addition to the graphical display of boat position and progress towards the desired waypoint.



**Figure 173 – Configuration of Rolling Road Display**

The following data items may be displayed on the rolling road display:

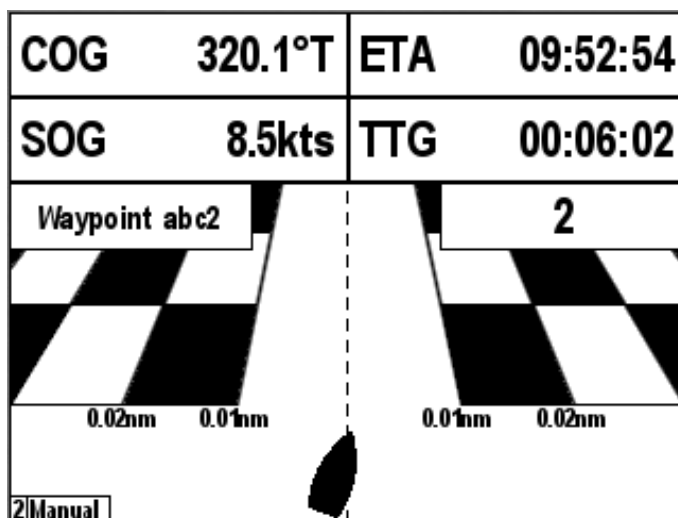
- COG (Course Over Ground)

# DSM250 User's Manual

---

- SOG (Speed Over Ground)
- BTW (Bearing to Waypoint)
- DTW (Distance to Waypoint)
- VMG (Velocity Made Good)
- ETA (Estimated Time of Arrival)
- TTG (Time to Go)
- XTE (Cross Track Error)
- Set
- Drift
- BOD (Bearing, Origin to Destination)
- HDG (Heading)

Figure 174 below shows a rolling road display. The navigation parameters that have been selected are COG, SOG, ETA, and TTG. On the navigation highway itself, the waypoint name, if available, is displayed on the upper left and the waypoint number, if available, is displayed on the upper right. The dashed vertical line along the center of the highway represents the current leg of the route. The distance of the boat to the left or the right of the line represents the XTE (Cross Track Error). The angle of the boat relative to the vertical line represents the difference between the boat's COG (Course Over Ground) and the BTW (Bearing to Waypoint). The scale of the XTE display can be selected by setting a value for the XTE alarm (See Section 5.2.1, "Alert Setup Menu", on page 26 for details).



*Figure 174 – Rolling Road Display*

## 7.7 Line Graph

The line graph display shows the value of a parameter displayed on the horizontal axis versus time on the vertical axis. Figure 175 below shows the line graph display for barometric pressure over a time period of one day. The line graph display can show the selected data over a time period of 1, 2, 3, 4, 5, 6, or 7 days. Line graph displays are supported only for barometric pressure.



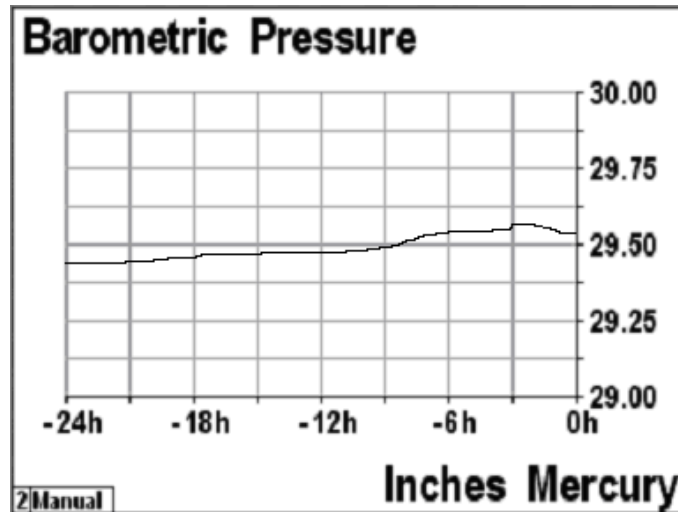


Figure 175 – Line Graph Display

## 7.8 Weather Display

The DSM250 supports a single-screen weather display that shows a wide variety of weather-related information. A screen shot of the weather display appears in Figure 176 below.

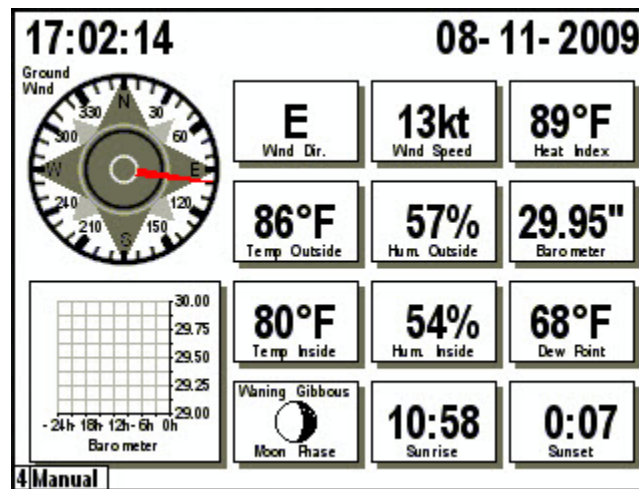


Figure 176 – Weather Display

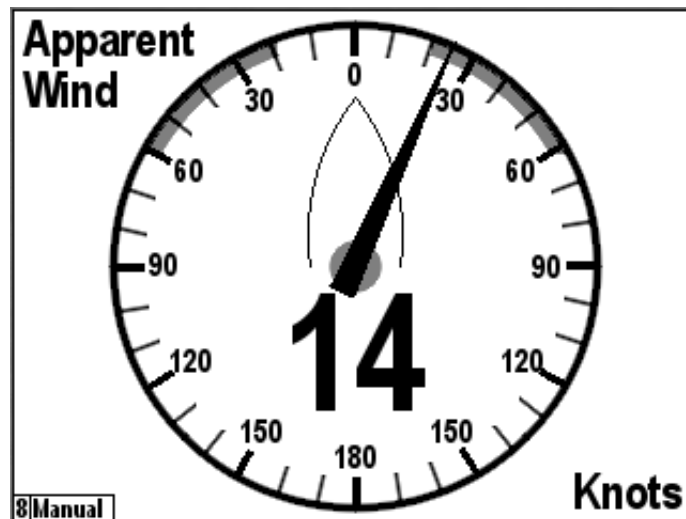
The weather display shows the following information

- Wind Direction (Ground Referenced)
- Wind Speed (Ground Referenced)
- Heat Index / Wind Chill
- Outside Temperature
- Outside Humidity
- Barometric Pressure
- Inside Temperature
- Inside Humidity
- Dew Point

- Moon Phase
- Sunrise
- Sunset

## 7.9 Wind Rose

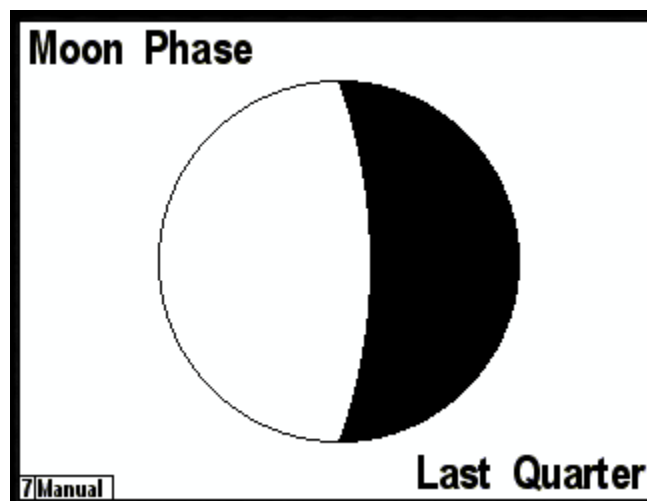
The DSM250 supports a wind rose display, which displays apparent wind direction and speed measured relative to the moving vessel, or true wind direction and speed measured relative to the moving vessel, depending on the parameter selected. A screen shot of a wind rose appears in Figure 177 below.



*Figure 177 – Wind Rose Display*

## 7.10 Moon Phase Display

The DSM250 supports a moon phase display which shows the current phase of the moon at the current location. An example screenshot of the moon phase display appears in Figure 178 below.



*Figure 178 – Moon Phase Display*

## 7.11 Trim Tab Display

The DSM250 supports a trim tab display in which the relative positions of the port and starboard trim tabs are displayed on a dual bar graph. A screenshot of the trim tab display appears in Figure 179 below.

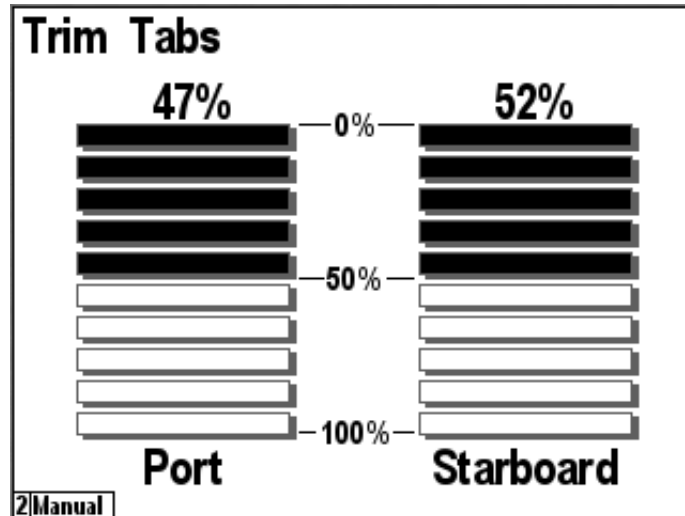


Figure 179 – Trim Tab Display

## 7.12 Swing Meter Display

The DSM250 supports a swing meter display, similar to those found on dedicated swing meters, for displaying the rate of turn of the vessel in degrees per minute. The swing meter is available in ranges of +/- 30°/minute, +/- 100°/minute, or +/- 300°/minute. A screenshot of the swing meter display appears in Figure 180 below.

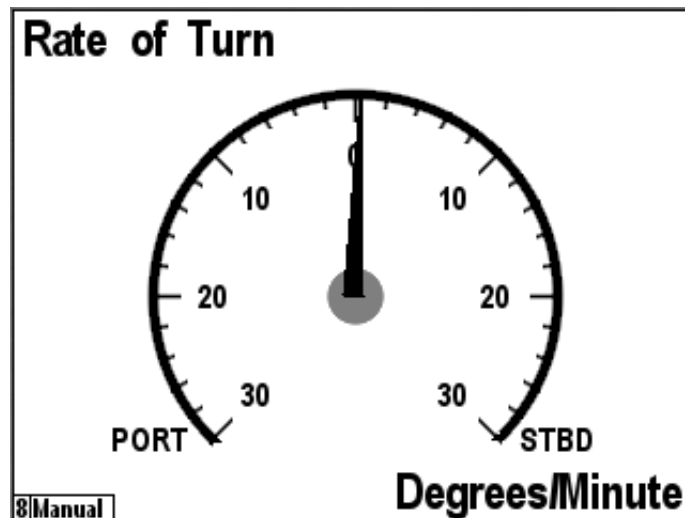
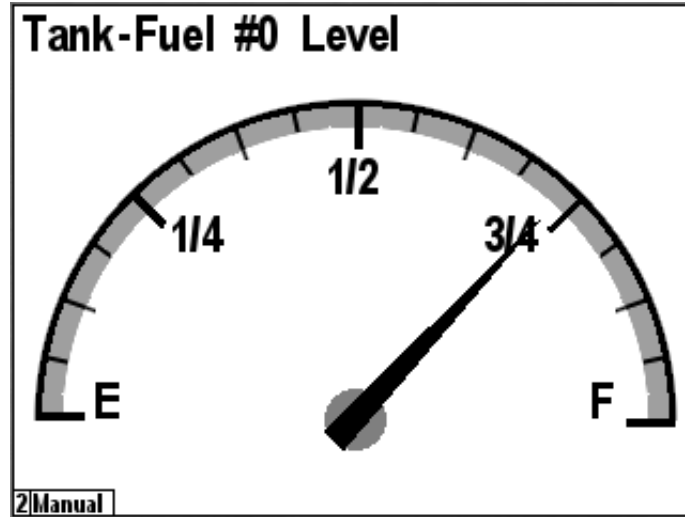


Figure 180 – Swing Meter Display

## 7.13 Tank Gauge Display

The DSM250 supports a tank level gauge display type which shows percentage of fluid remaining in a tank on an analog gauge with 180° of travel. A screenshot of a tank gauge display showing a fuel tank's level appears in Figure 181 below.



*Figure 181 – Tank Gauge Display*

## 8 Alerts

The DSM250 can act as both an Alert Source and an Alert Monitor. An Alert Source monitors parameters received on the NMEA2000® bus against a user entered threshold, and displays alerts when parameters go out of range. It will also transmit this Alert information to other Alert Monitors on the bus (Platinum copies of N2KView™ or other DSM250s) and sound the ALM100 annunciators as required. Operators may accept or cancel the Alerts from the buttons on the front of the DSM250. An Alert Monitor, the DSM250 monitors the bus for Alert messages from Alert Sources, and displays the remote Alert information on the DSM250's screen. Operators may accept or cancel the remote Alerts from the buttons on the front of the DSM250, in which case an Alert Command Message is sent back to the Alert Source.

### 8.1 Displaying Active Alerts

Active Alerts are overlaid on all the favorite screens.

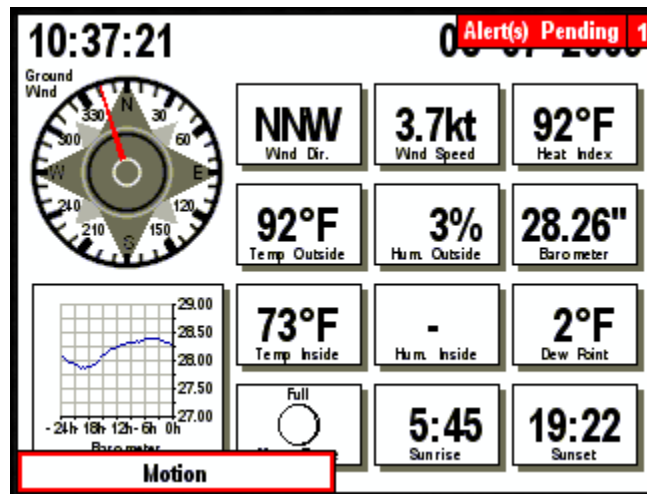


Figure 182 – Alert Display

The number of Alerts with pending operator actions is shown in the top right corner. This will be colored red if the highest pending Alert is an Alarm and yellow if it is a Warning. The description of the active Alert with the highest priority is shown at the bottom left of the screen. This will be colored red if it is an Alarm and yellow if it is a Warning. In addition, the state of the alert (0) will be shown as follows:

**Active** – The enclosing box will flash between a solid red or yellow and white.

**Accepted** – The enclosing box will be a solid red or yellow.

**Awaiting Cancel** – The enclosing box will be outlined in red or yellow, as shown in Figure 182.

#### 8.1.1 Alert Status Screen

The list of Active Alerts is displayed in tabular form on the Alert Status Screen. This Screen may be displayed by selecting the **Alert Status** option from the Main Menu.

The screenshot shows a terminal window titled "Alert Status...". In the top right corner, there is a red box containing the text "Alert(s) Pending 1". Below this is a table with the following data:


Time	State	Source	Pri.	Description
08/07 10:49:39	Inactive	Local	3	Anchor Watch
08/07 10:46:49	Awaiting	Local	5	Motion

At the bottom of the screen, there are five buttons: "Power", "Back", "Scroll Up", "Scroll Down", and "Enter".

## 8.2 Accepting or Cancelling an Alert

Active Alerts may be accepted (4.3.2) by the operator to indicate that the operator has taken responsibility for the Alert. Alerts that have been triggered and the cause removed without being accepted by a user must be cleared.

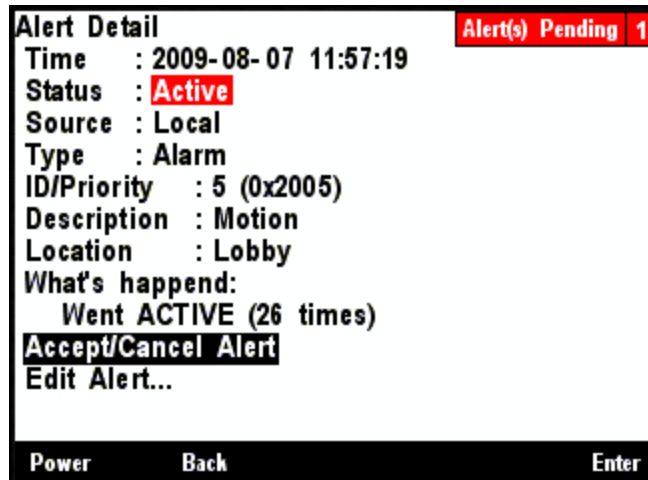
### 8.2.1 From a Favorite Screen

The Alert with the highest priority that requires accepting or cancelling is shown at the bottom left of the screen (see Figure 182). This Alert may easily be accepted or cancelled without changing screens by pressing the Power button .

### 8.2.2 From the Alert Status Screen

This screenshot is identical to the one above, showing the "Alert Status..." screen with the same table of alerts and navigation buttons.

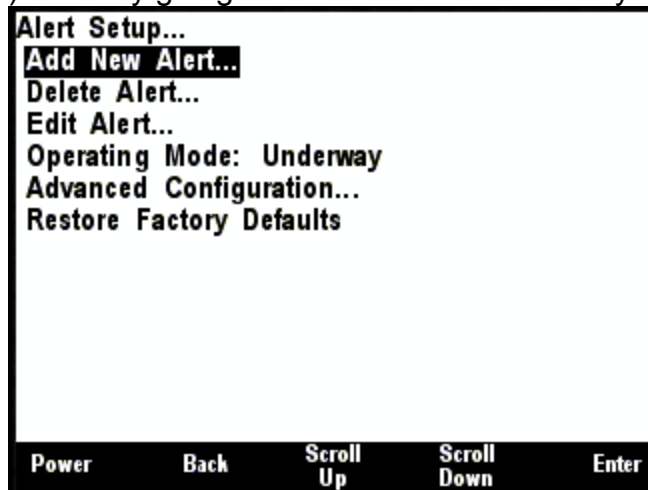
Use the **Scroll Up** and **Scroll Down** buttons to select the Alert to be accepted or cancelled, and then press the **Enter** button. An Alert Description screen will be displayed with the details of the Alert and the cursor positioned over the **Accept/Cancel Alert** entry.



Pressing the **Enter** button at this point will **Accept** or **Cancel** the Alert.

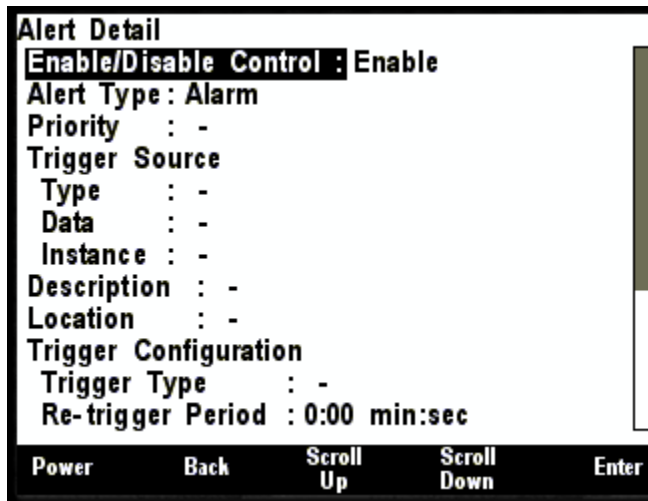
## 8.3 Adding an Alert

Alerts are created by selecting the parameter to be monitored (e.g. Depth), and then selecting the type of Alert (e.g. High Alert). Start by going to the **Add New Alert** entry in the **Alert Setup Menu**.



*Figure 183 – Adding a New Alert*

Pressing **Enter** brings up the Alert Edit Screen.



*Figure 184 – Part of the Alert Edit Screen*

This allows the entry of all the alert parameters, which can vary depending on the type of alert chosen. These parameters are:

### 8.3.1 Enable/Disable Control

This allows individual alerts to be enabled or disabled. The decision to disable an Alert must be made very carefully, as it nullifies the purpose for having alerts. The options here are:

- Enable
- Disable

The desired option is selected using the Scroll Up and Scroll Down buttons.

### 8.3.2 Alert Type

This allows the selection of the type of Alert (see paragraph 0). The options here are:

- Alarm
- Warning

The desired option is selected using the Scroll Up and Scroll Down buttons.

### 8.3.3 Priority

Each Alarm has a unique priority ranging from 0 (highest priority) to 3999 (lowest priority). Each Warning has a unique priority in the same range; however the entire set of Warning Priorities is considered lower than the Alarm Priorities. No two Alarms / Warnings may have the same priorities, and, when scrolling through the priorities, numbers that are already in use will be omitted from the list. The desired option is selected using the Scroll Up and Scroll Down buttons.



## 8.3.4 Trigger Source

This allows the selection of the parameter to be monitored. The parameters are laid out as per section 4.2. The trigger source is specified in three parts, which when combined will uniquely identify a single parameter on the bus.

### 8.3.4.1 Type

The Type corresponds to the category of data.

The desired option is selected using the Scroll Up and Scroll Down buttons.

### 8.3.4.2 Data

The Data corresponds to the Data Type of data.

The desired option is selected using the Scroll Up and Scroll Down buttons.

### 8.3.4.3 Instance

The Instance corresponds to the instance of the data type on the bus.

The desired option is selected using the Scroll Up and Scroll Down buttons.

## 8.3.5 Description

This is a textual field that will be displayed on the DSM250 and transmitted to Alert Slave devices. It is intended to describe the alert (e.g. Fire).

## 8.3.6 Location

This is a textual field that will be displayed on the DSM250 and transmitted to Alert Slave devices. It is intended to describe the location at which the problem was detected (e.g. Main Stateroom).

## 8.3.7 Trigger Configuration

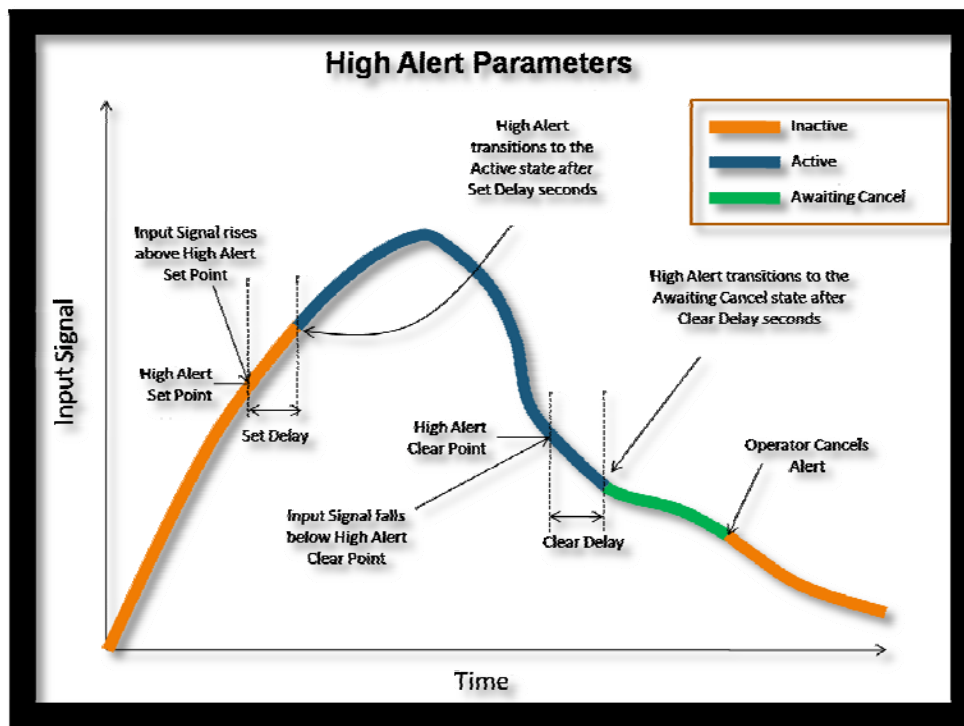
This set of fields is used to describe the condition under which the alert will be triggered. The sub-fields will vary depending on the Trigger Type, which, in turn, is determined by the Trigger Source.

### 8.3.7.1 Trigger Type is High Alert

A high alert is used to signal you when a parameter value rises above a threshold you determine. For example, you can set an alert to occur whenever the freezer temperature rises above 0°C.

#### 8.3.7.1.1 Description

A high alert and associated diagram are shown in the figure below.



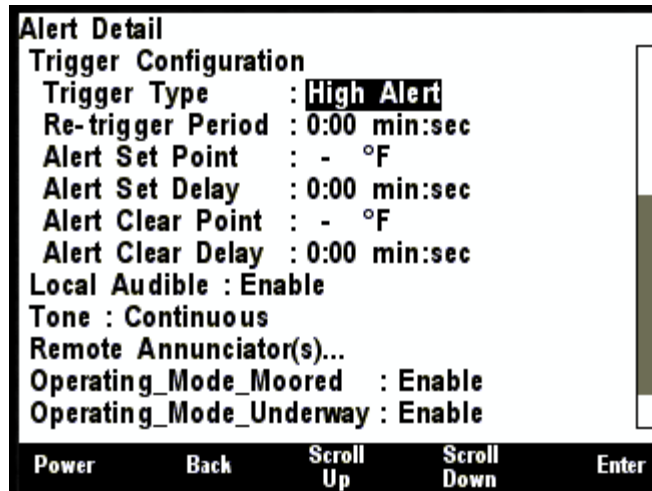
**Figure 185 – High Alert Parameters**

A high alert is triggered (i.e. becomes an active alert) once an input signal has risen above the *High Alert Set Point* and the *Set Delay* time has elapsed. If the *Set Delay* is set to zero, then the alert is immediately triggered once the input signal rises above the *High Alert Set Point*. The *Set Delay* is used to reduce false or spurious alerts. As an example, setting the *Set Delay* to 5 seconds will eliminate any temporary transitions of the input signal above the *High Alert Set Point* lasting less than 5 seconds from triggering an alert. Once the alert is triggered, it becomes an active alert. An alert remains active until

- The input signal falls below the *High Alert Clear Point* and the *Clear Delay* time has elapsed. If the *Clear Delay* is set to zero, then the alert immediately transitions to the Awaiting Cancel once the input signal falls below the *High Alert Clear Point* (as shown in the example above).
- The user accepts the alert in which case it transitions into the Accepted state.

The *Clear Delay* is used to reduce false or spurious alerts.

### 8.3.7.1.2 Trigger Configuration



**Figure 186 – Trigger Configuration – High Alert**

**Re-trigger Period** – When you accept an alert, it will change to the “Accepted” state, and annunciators that are sounding for that alert will stop sounding. If the condition which caused the alert remains true after the amount of time in this field, the alert will return to the “Active” state, and annunciators will begin sounding again for that alert. The value is entered as minutes:seconds. If only one number is entered, it will be interpreted as seconds.

**Alert Set Point** – If the value of the parameter being monitored rises above the value in this field, the alert will become active.

**Alert Set Delay** – The parameter being monitored must rise above the Alert Set Point value for longer than the time in this field in order for an alert to become active. This can be used to prevent false alerts caused by parameter values that briefly have a value that would cause an alert but quickly return to the normal value range. The value is entered as minutes:seconds. If only one number is entered, it will be interpreted as seconds.

**Alert Clear Point** – If the alert is active and the parameter value falls below the value in this field, the alert will become inactive.

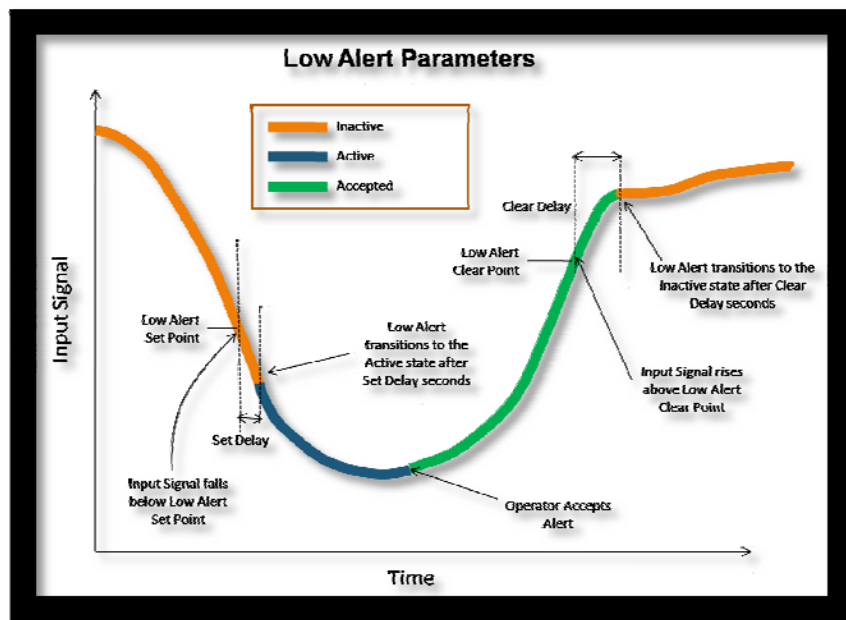
**Alert Clear Delay** – The parameter being monitored must fall below the Alert Clear Point value for longer than the time in this field in order for the alert to become inactive. The value is entered as minutes:seconds. If only one number is entered, it will be interpreted as seconds.

### 8.3.7.2 Trigger Type is Low Alert

A low alert is used to signal you when a parameter value falls below a threshold you determine. For example, you can set an alert to occur whenever the port engine oil pressure rises falls below 40 PSI.

#### 8.3.7.2.1 Parameters

A low alert and associated diagram are shown in the figure below.

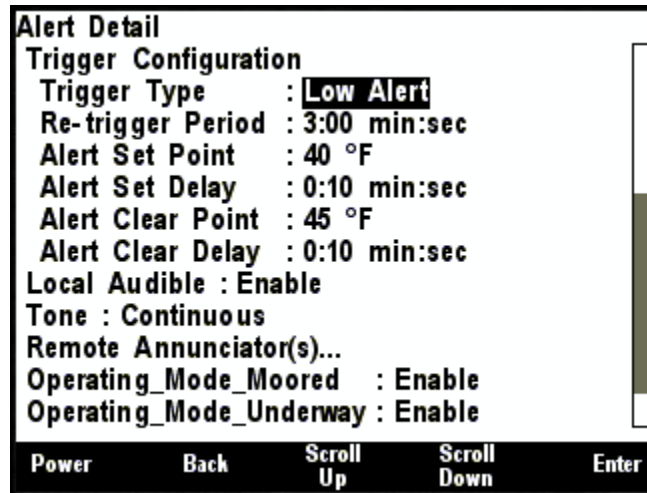


**Figure 187 – Low Alert Parameters**

A low alert is triggered (i.e. becomes an active alert) once an input signal has dropped below the *Low Alert Set Point* and the *Set Delay* time has elapsed. If the *Set Delay* is set to zero, then the alert is immediately triggered once the input signal drops below the *Low Alert Set Point*. The *Set Delay* is used to reduce false or spurious alerts. As an example, setting the *Set Delay* to 5 seconds will eliminate any temporary transitions of the input signal above the *Low Alert Set Point* lasting less than 5 seconds from triggering an alert. Once the alert is triggered, it becomes an active alert. An alert remains active until:

- The input signal rises above the *Low Alert Clear Point* and the *Clear Delay* time has elapsed. If the *Clear Delay* is set to zero, then the alert immediately becomes inactive once the input signal falls below the *Low Alert Clear Point*. The *Clear Delay* is used to reduce false or spurious alerts.
- The user accepts the alert (as shown in the example above).

## 8.3.7.2.2 Trigger Configuration



**Figure 188 - Trigger Configuration – Low Alert**

**Re-trigger Period** – When you accept an alert, it will change to the “Accepted” state, and annunciators that are sounding for that alert will stop sounding. If the condition which caused the alert remains true after the amount of time in this field, the alert will return to the “Active” state, and annunciators will begin sounding again for that alert.

**Alert Set Point** – If the value of the parameter being monitored falls below the value in this field, the alert will become active.

**Alert Set Delay** – The parameter being monitored must fall below the Low Alert Set Point value for longer than the time in this field in order for an alert to become active. This can be used to prevent false alerts caused by parameter values that briefly have a value that would cause an alert but quickly return to the normal value range. The value is entered as minutes:seconds. If only one number is entered, it will be interpreted as seconds.

**Alert Clear Point** – If the alert is active and the parameter value rises above the value in this field, the alert will become inactive.

**Alert Clear Delay** – The parameter being monitored must rise above the Low Alert Clear Point value for longer than the time in this field in order for the alert to become inactive. The value is entered as minutes:seconds. If only one number is entered, it will be interpreted as seconds.

In this example, the set point may be described in more than one unit, so additional fields have been supplied so that the user can select the units of depth. Changing the units of the set point will also change the units of the clear point. The initial units displayed in these fields will correspond to those set in the Units Menu (see section 5.2.7).

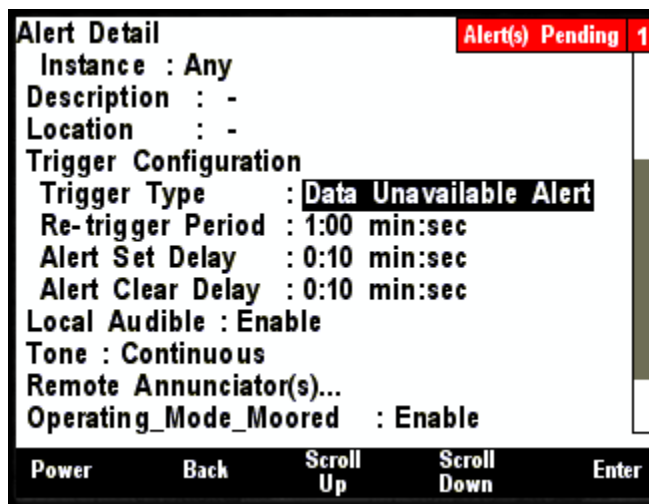
## 8.3.7.3 Trigger Type is Data Unavailable Alert

The Data Unavailable Alert can be used in conjunction with other alert types when you need to know if a particular parameter is no longer being received on the network or is flagged as “not available” by the transmitting device. For instance, you probably would want to use a Data Unavailable Alert for the Depth->Current Depth parameter, since it would be advisable to know if the depth sounder were to stop transmitting a depth reading or became unable to determine the depth due to fouling or some other reason. On the other hand, if you were to set a Data Unavailable Alert on Engine->Engine

# DSM250 User's Manual

Water Temperature parameter, you would then get an alert every time the ignition was switched off and the engine's ECU stopped transmitting data.

## 8.3.7.3.1 Trigger Configuration



*Figure 189 – Trigger Configuration – Data Unavailable Alert*

**Re-trigger Period** – When you accept an alert, it will change to the “Accepted” state, and annunciators that are sounding for that alert will stop sounding. If the condition which caused the alert remains true after the amount of time in this field, the alert will return to the “Active” state, and annunciators will begin sounding again for that alert.

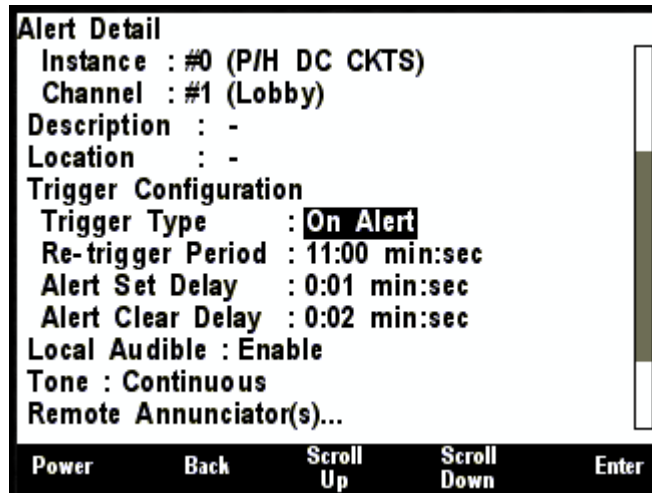
**Alert Set Delay** – If a valid value for the parameter being monitored is continually not received or has an invalid value for the amount of time specified in this field, the alert will become active.

**Alert Clear Delay** – The parameter being monitored must continually be received with a valid value for longer than the time in this field in order for the alert to become inactive.

## 8.3.7.4 Trigger Type is On Alert

As opposed to high and low alerts that are associated with analog input signals (i.e., many different possible input values), there are also switch alerts that are associated with a binary input value (sometimes called on or off, yes or no, enabled or disabled, set or reset, active or inactive). The switch alert is similar to the high and low alert except that there are no set or reset points. The mere fact that the switch is seen as On causes the alert to become an active alert (assuming the Set Delay is set to zero). Likewise, if the switch being monitored is seen as false (i.e., binary 0), then the alert becomes inactive (assuming the Clear Delay is set to zero). If the delays are not programmed to zero, then the switch must remain On for the Set Delay before the alert becomes active, and must remain Off for the Clear Delay before the alert becomes inactive.

### 8.3.7.4.1 Trigger Configuration



**Figure 190 – Trigger Configuration – On Alert**

**Accept Re-trigger Period** – When you accept an alert, it will change to the “Accepted” state, and annunciators that are sounding for that alert will stop sounding. If the condition which caused the alert remains true after the amount of time in this field, the alert will return to the “Active” state, and annunciators will begin sounding again for that alert.

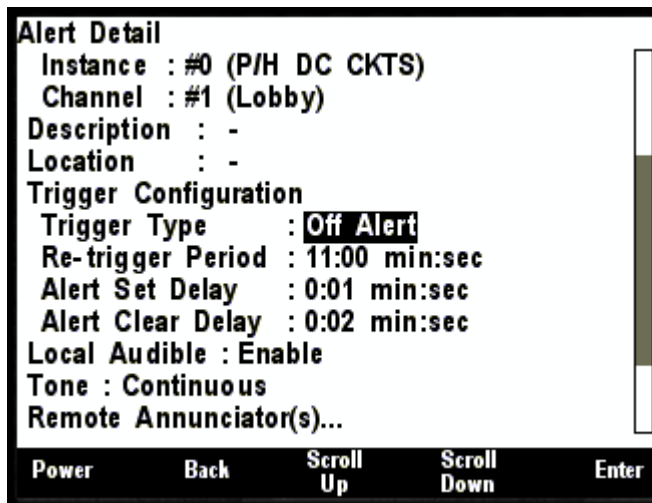
**Alert Set Delay** – The condition for the parameter being monitored must be in its error condition for at least the set delay time before the alert will become active. An interesting use of the set delay when monitoring a bilge pump (for example) is to set the Set Delay to a large value (say 20 minutes). Now, if the bilge pump runs for more than 20 minutes at a time the alert will be triggered.

**Alert Clear Delay** – The condition for the parameter being monitored must be not in its error condition for at least the clear delay time before the alert will become cleared.

### 8.3.7.5 Trigger Type is Off Alert

As opposed to high and low alerts that are associated with analog input signals (i.e., many different possible input values), there are also switch alerts that are associated with a binary input value (sometimes called on or off, yes or no, enabled or disabled, set or reset, active or inactive). The switch alert is similar to the high and low alert except that there are no set or reset points. The mere fact that the switch is seen as Off causes the alert to become an active alert (assuming the Set Delay is set to zero). Likewise, if the switch being monitored is seen as On, then the alert becomes inactive (assuming the Clear Delay is set to zero). If the delays are not programmed to zero, then the switch must remain Off for the Set Delay before the alert becomes active, and must remain On for the Clear Delay before the alert becomes inactive.

#### 8.3.7.5.1 Trigger Configuration



*Figure 191 – Trigger Configuration – Data Unavailable Alert*

**Re-trigger Period** – When you accept an alert, it will change to the “Accepted” state, and annunciators that are sounding for that alert will stop sounding. If the condition which caused the alert remains true after the amount of time in this field, the alert will return to the “Active” state, and annunciators will begin sounding again for that alert.

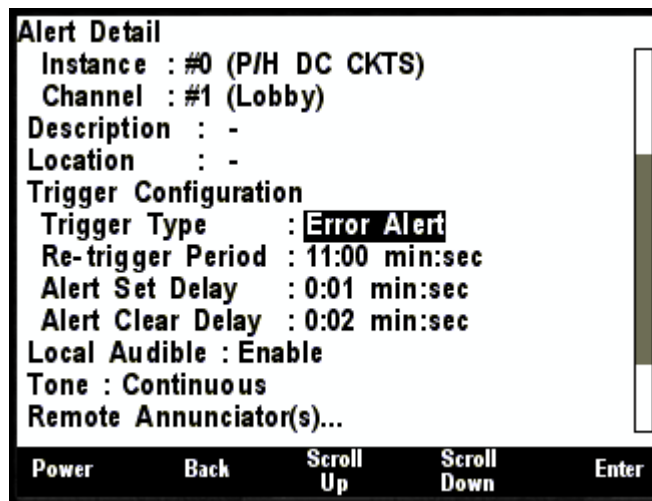
**Alert Set Delay** – If the switch being monitored is in the Off state for the amount of time specified in this field, the alert will become active.

**Alert Clear Delay** – If the switch being monitored is in a state other than “Off” for the amount of time specified in this field, the alert will become inactive.

### 8.3.7.6 Trigger Type is Error Alert

When monitoring circuit breakers, the error alert can be used to raise an alert when the circuit breaker trips due to over current. As with the On and Off alerts, the Set Delay and Clear Delay values are used to prevent spurious triggering.

#### 8.3.7.6.1 Trigger Configuration



*Figure 192 – Trigger Configuration Editor - Tripped Alert*



**Re-trigger Period** – When you accept an alert, it will change to the “Accepted” state, and annunciators that are sounding for that alert will stop sounding. If the condition which caused the alert remains true after the amount of time in this field, the alert will return to the “Active” state, and annunciators will begin sounding again for that alert.

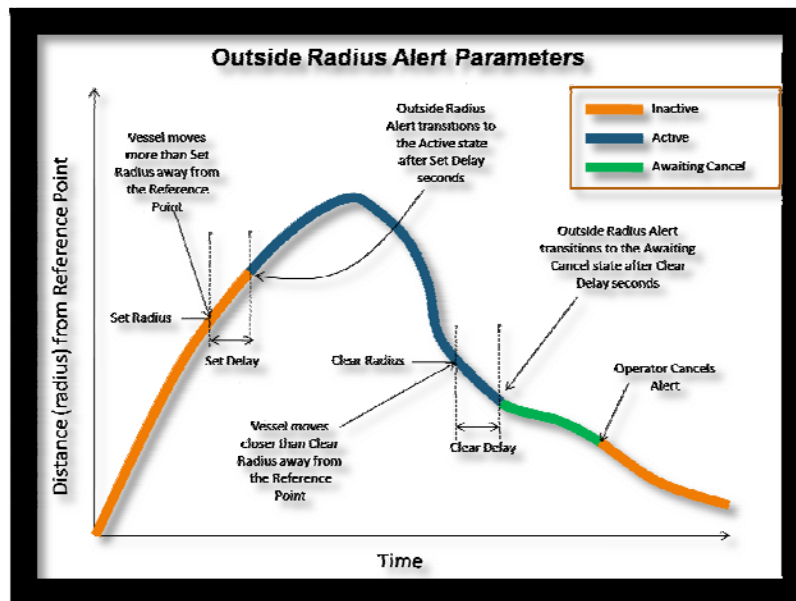
**Alert Set Delay** – If the switch being monitored is in the Tripped state for the amount of time specified in this field, the alert will become active.

**Alert Clear Delay** – If the switch being monitored is in a state other than “Tripped” for the amount of time specified in this field, the alert will become inactive.

### 8.3.7.7 Trigger Type is Outside Radius Alert

The Outside Radius Alert is used to signal an alert whenever the vessel moves outside a programmable distance in any direction away from a reference point (expressed as a longitude and latitude). This alert is useful when the vessel is anchored or moored and the vessel should not drift outside a perimeter and if it does, an alert is activated. The point of reference can be selected from the current position or it can be manually entered. Figure 193 shows an Outside Radius Alert and associated parameters. The Outside Radius Alert and the Anchor Alert are very similar. The radius of the Outside Radius Alert is specified in either Nautical Miles or Kilometers, while the radius of the Anchor Alert is specified in Feet or Meters.

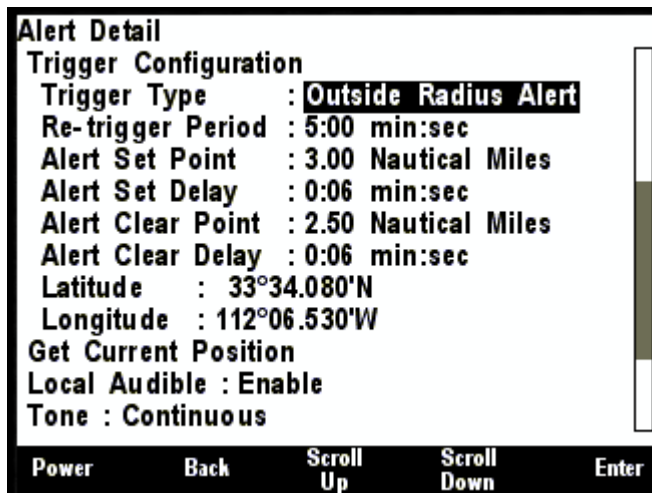
#### 8.3.7.7.1 Parameters



**Figure 193 – Outside Alert Parameters**

# DSM250 User's Manual

## 8.3.7.7.2 Trigger Configuration – Outside Radius Alert



*Figure 194 - Trigger Configuration – Outside Radius Alert*

**Re-trigger Period** – When you accept an alert, it will change to the “Accepted” state, and annunciators that are sounding for that alert will stop sounding. If the condition which caused the alert remains true after the amount of time in this field, the alert will return to the “Active” state, and annunciators will begin sounding again for that alert.

**Alert Set Point** – If the distance between the current GPS position and the reference position rises above the value in this field, the alert will become active.

**Alert Set Delay** – The distance between the current GPS position and the reference position must rise above the Outside Radius Alert Set value for longer than the time in this field in order for an alert to become active.

**Alert Clear Point** – If the alert is active and the distance between the current GPS position and the reference position falls below the value in this field, the alert will become inactive.

**Alert Clear Delay** – The distance between the current GPS position and the reference position must fall below the Outside Radius Alert Clear value for longer than the time in this field in order for an alert to become inactive.

**Latitude** – The latitude of the reference position. This may be typed in as <degrees>:<minutes> followed by an N or S. If the N or S is missing, North is assumed. Moving the cursor to another field will reformat the contents of this field.

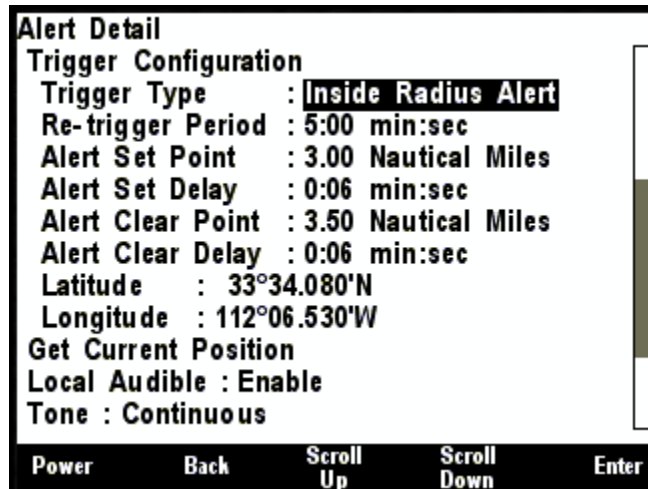
**Longitude** – The longitude of the reference position. This may be typed in as <degrees>:<minutes> followed by an E or W. If the E or W is missing, East is assumed. Moving the cursor to another field will reformat the contents of this field.

**Get Current Position** – Selecting this will transfer the current GPS position into the Latitude and Longitude fields.

## 8.3.7.8 Trigger Type is Inside Radius Alert

The Inside Radius Alert is similar to the Outside Radius Alert except that an alert is activated if the vessel comes within a certain distance or radius of a reference point (expressed as a longitude and latitude). Figure 195 shows an Inside Radius Alert and associated parameters.

## 8.3.7.8.1 Trigger Configuration



**Figure 195 – Trigger Configuration - Inside Radius Alert**

**Re-trigger Period** – When you accept an alert, it will change to the “Accepted” state, and annunciators that are sounding for that alert will stop sounding. If the condition which caused the alert remains true after the amount of time in this field, the alert will return to the “Active” state, and annunciators will begin sounding again for that alert.

**Alert Set Point** – If the distance between the current GPS position and the reference position falls below above the value in this field, the alert will become active.

**Alert Set Delay** – The distance between the current GPS position and the reference position must fall below the Inside Radius Alert Set value for longer than the time in this field in order for an alert to become active.

**Alert Clear Point** – If the alert is active and the distance between the current GPS position and the reference position rises above the value in this field, the alert will become inactive.

**Alert Clear Delay** – The distance between the current GPS position and the reference position must rise above the Inside Radius Alert Clear value for longer than the time in this field in order for an alert to become inactive.

**Latitude** – The latitude of the reference position. This may be typed in as <degrees>:<minutes> followed by an N or S. If the N or S is missing, North is assumed. Moving the cursor to another field will reformat the contents of this field.

**Longitude** – The longitude of the reference position. This may be typed in as <degrees>:<minutes> followed by an E or W. If the E or W is missing, East is assumed. Moving the cursor to another field will reformat the contents of this field.

**Get Current Position** – Selecting this line will transfer the current GPS position into the Latitude and Longitude fields.

## 8.3.7.9 Trigger Type is Anchor Alert

The Anchor Alert is a special case of the Outside Radius Alert (section 8.3.7.7). It is used to signal an alert whenever the vessel moves outside a programmable distance in any direction away from a reference point (expressed as a longitude and latitude). This alert is useful when the vessel is anchored or moored and the vessel should not drift outside a perimeter and if it does, an alert is activated. The point of reference can be selected from the current position or it can be manually entered.

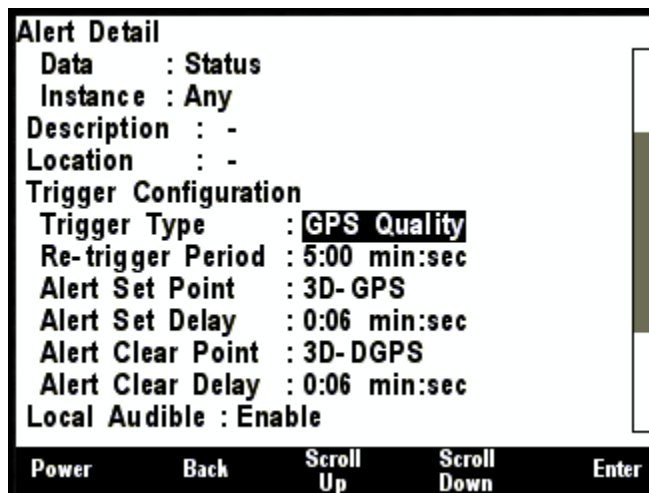
# DSM250 User's Manual

The Outside Radius Alert and the Anchor Alert are very similar. The Anchor Alert is designed to allow the input of relatively small radius values, and may be displayed graphically through the Anchor Watch Display (section 7.1). The radius of the Outside Radius Alert is specified in either Nautical Miles or Kilometers, while the radius of the Anchor Alert is specified in Feet or Meters. See Section 8.3.7.7 for details of the configuration of the Anchor Alert.

## 8.3.7.10 Trigger Type is GPS Quality Alert

The accuracy, or quality, of a position fix provided by a GPS is dependent on the number of satellites used to compute the position. A position based on less than three satellites is considered a “1D” lock, three satellites is a “2D” lock, more than three satellites is a “3D” lock, and more than three satellites with SBAS is a “3D-DGPS” lock. These different locks are indicative of the quality or accuracy of the given position with 1D having the lowest quality and 3D-DGPS providing the highest quality. The GPS Quality Alert is used to alert you if the quality of the position falls below a specified quality level.

### 8.3.7.10.1 Trigger Configuration – GPS Quality Alert



*Figure 196 – Trigger Configuration - GPS Quality Alert*

**Re-trigger Period** – When you accept an alert, it will change to the “Accepted” state, and annunciators that are sounding for that alert will stop sounding. If the condition which caused the alert remains true after the amount of time in this field, the alert will return to the “Active” state, and annunciators will begin sounding again for that alert.

**Alert Set Point** – The Alert will be triggered when the quality of the GPS fix, as reported by the GPS drops lower than the value specified in this field.

Possible Values are:

- 3D-DGPS (best quality)
- 3D-GPS
- 2D-GPS
- 1D-GPS
- No fix

**Alert Set Delay** – When the quality of the GPS fix becomes lower than the quality specified in the Alert Set Point field for longer than the time specified in the Alert Set Delay field, the alert will become active.

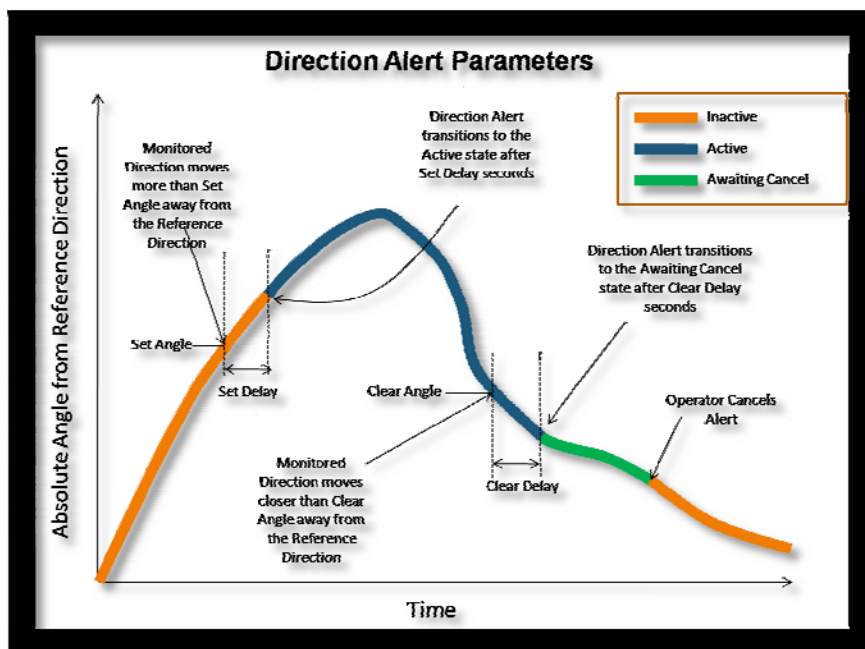
**Alert Clear Point** – The Alert will be cleared when the quality of the GPS fix, as reported by the GPS becomes better than the value specified in this field.

Possible values are the same as the Alert Set Point.

**Alert Clear Delay** – If the alert is active and the quality of the GPS fix becomes higher than the quality specified in the Alert Clear Point field for longer than the time specified in the Clear Delay field, the alert will become inactive.

### 8.3.7.11 Trigger Type is Direction Alert

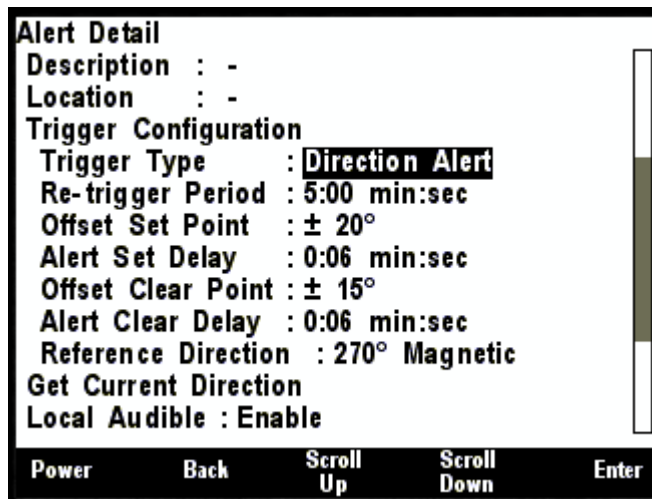
A Direction Alert is used to indicate that a heading or wind direction has changed from the reference direction more than a programmable amount. For example, once a heading has been established, an alert can be generated if the heading changes more than a specified amount. Direction Alerts may also be set for wind direction. The reference direction can be selected from the current direction (heading or wind direction) or it can be manually entered. Figure 197 shows a Direction Alert and associated parameters.



**Figure 197 – Direction Alert Parameters**

# DSM250 User's Manual

## 8.3.7.11.1 Trigger Configuration – Direction Alert



*Figure 198 – Trigger Configuration - Direction Alert*

**Re-trigger Period** – When you accept an alert, it will change to the “Accepted” state, and annunciators that are sounding for that alert will stop sounding. If the condition which caused the alert remains true after the amount of time in this field, the alert will return to the “Active” state, and annunciators will begin sounding again for that alert.

**Offset Set Point, Offset Set Delay** – If the direction being monitored differs from the reference direction by more than the Offset Heading Set Point for longer than the time specified in the Set Delay field, the alert will become active.

**Offset Clear Point, Offset Clear Delay** – If the alert is active and the direction being monitored differs from the reference direction by less than the Offset Heading Clear Point for longer than the time specified in the Clear Delay field, the alert will become inactive.

**Reference Heading / Reference Direction / Reference Course** – Enter the desired reference heading or direction into this field. If the monitored value differs from this value by more than the Offset Heading Set Point, the alert will be triggered.

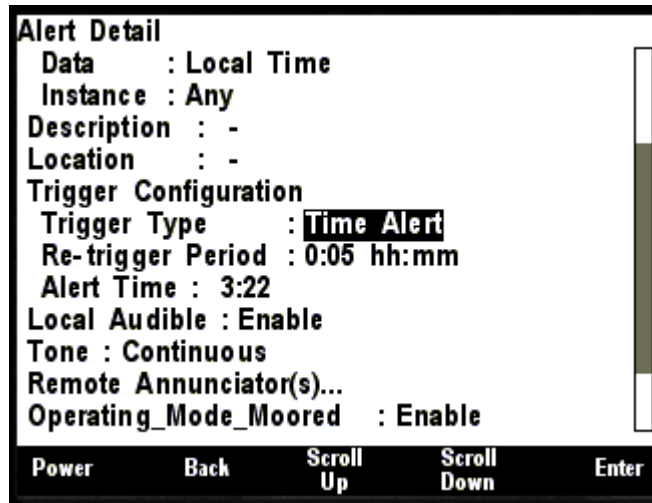
**Get Current Heading / Get Current Direction / Get Current Course** – Pressing or clicking on this button will transfer the current value of the heading or direction being monitored into the Reference Heading / Reference Direction Field.

### 8.3.7.12 Trigger Type is Time Alert

The DSM250 can be configured with alerts that go active at a predetermined time, such as an alarm clock. These alerts can also be configured to become active periodically, making them useful for signaling watch changes (for example, every four hours) or as a personnel alarm (making sure a crew member is at the helm every 15 minutes).

When a Time Alert with a Repeat Interval of zero is accepted, it will be Disabled to prevent further triggering. When a Time Alert with a Repeat Interval greater than zero is accepted, it will transition to the Inactive state, waiting for the next time it should trigger.

## 8.3.7.12.1 Trigger Configuration – Time Alert



*Figure 199 - Alert Editor - Time Alert*

**Alert Time** – The alert will become active at the time specified in this field. If the time specified has already passed, then the alarm will be set for the next day. Entering a number without the colon will assume that the hours are zero.

**Repeat Interval** – The alert will become active again after the period specified in this field. For example, if the Alarm Time were set to 8:00 and the Repeat Interval were set to 1:00 (1 hour, zero minutes), the Alarm would become active again at 9:00, 10:00, and so on.

### 8.3.8 Local Audible

If the Local Audible field is set to **Enabled**, the speaker internal to the DSM250 will be activated when this Alert is triggered.

### 8.3.9 Tone

If Local Audible is enabled, the tone that is sounded on the DSM250 and the Remote Annunciators can be set here. This allows the user to configure the Alerts so that the alert can be identified from the tone. The values for Tone are:

**Beeps** – A continuous series of half second on, half second off beeps is sounded. This corresponds to the requirements for IMO Code 3.a

**Continuous** – A continuous tone is sounded. This corresponds to the requirements for IMO Code 2

**General Emergency** – A series of seven one second on, one second off tones are sounded, followed by a single tone of 7 seconds on. The sequence is repeated. This corresponds to the requirements for IMO Code 1a (7 pulse) (General Emergency Alarm, SOLAS III/50, III/6.4)

**Carbon Monoxide** - This is a series of four one tenth second on, one tenth second off beeps followed by one and a half seconds of silence. The sequence is repeated. This corresponds to the requirements for Temporal 4 alarms \*(T4, CO)

**Fire** – This is a series of three half a second on, half a second off beeps followed by one and a half seconds of silence. The sequence is repeated. This corresponds to the requirements for Code-3 (ISO 8201, Smoke/Fire)



# DSM250 User's Manual

---

## 8.3.10 Remote Annunciators

Selecting the Remote Annunciators option will bring up a list of 16 ALM100 devices. If the Annunciator is active on the NMEA2000® bus, and the Annunciator has been given a label, the label will be displayed, in parenthesis, alongside the instance number.

**Note:** the DSM250 is limited to working with annunciators with data instance numbers in the range 0-15.

Instance	Tone
#0 (Bridge)	Enable
#1	Disable
#2	Disable
#3	Disable
#4	Disable
#5	Disable
#6	Disable
#7	Disable
#8	Disable
#9	Disable

To enable a specific Annunciator, use the **Scroll Up** and **Scroll Down** buttons to position the cursor, and then press the **Enter** button to move to the Tone column.

The options here are

- Enable
- Disable

The desired option is selected using the **Scroll Up** and **Scroll Down** buttons, and then pressing the **Enter** button again. The tone of the Annunciator will be the same as that set in 8.3.9.

## 8.3.11 Operating Mode Moored

See section 4.3.4 for a description of Operating Modes. For this Alert to be triggered when the vessel is in the **Moored** state, this option must be set to Enabled.

The options here are

- Enable
- Disable

The desired option is selected using the **Scroll Up** and **Scroll Down** buttons, and then pressing the **Enter** button again.

## 8.3.12 Operating Mode Underway

See section 4.3.4 for a description of Operating Modes. For this Alert to be triggered when the vessel is in the **Underway** state, this option must be set to Enabled. The options here are

- Enable
- Disable



The desired option is selected using the **Scroll Up** and **Scroll Down** buttons, and then pressing the **Enter** button again.

### 8.3.13 Operating Mode Anchored

See section 4.3.4 for a description of Operating Modes. For this Alert to be triggered when the vessel is in the **Anchored** state, this option must be set to Enabled. The options here are

- Enable
- Disable

The desired option is selected using the **Scroll Up** and **Scroll Down** buttons, and then pressing the **Enter** button again.

### 8.3.14 Scope

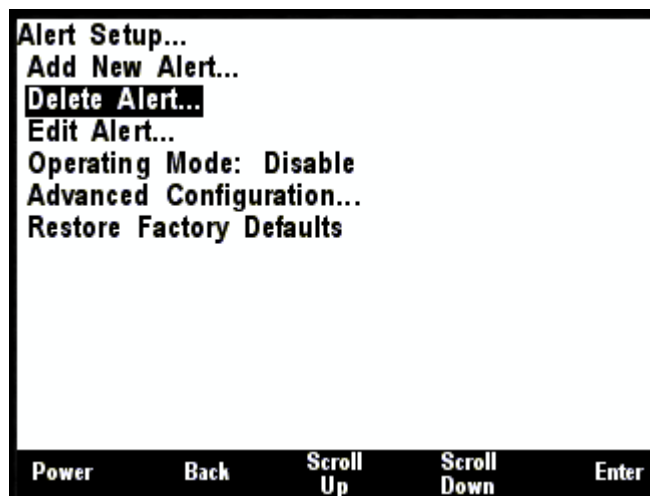
Alerts may be constrained to be displayed only on the DSM250 where they are detected. In this case the Alert message is not sent out on the NMEA2000 bus, and other devices will not display the alert, or allow Accepting or Cancelling. The Scope does not affect the generation of Annunciator messages. The options here are

- Local – the Alert messages are not transmitted
- Global – the Alert messages are transmitted

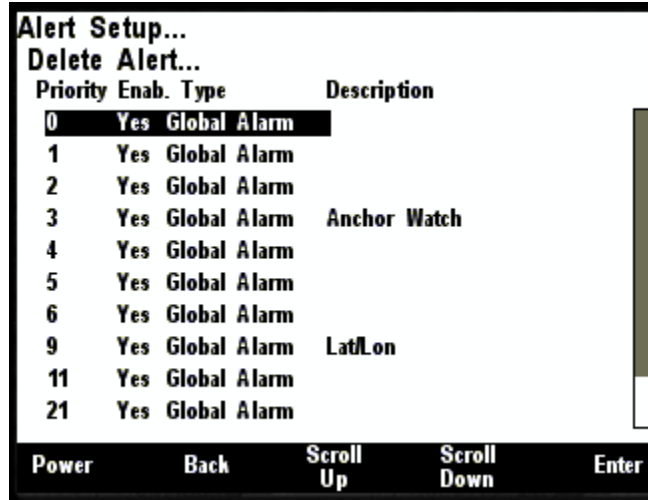
The desired option is selected using the **Scroll Up** and **Scroll Down** buttons, and then pressing the **Enter** button again.

## 8.4 Deleting an Alert

From the **Alert Setup Menu**, selected the menu item **Delete Alert...**

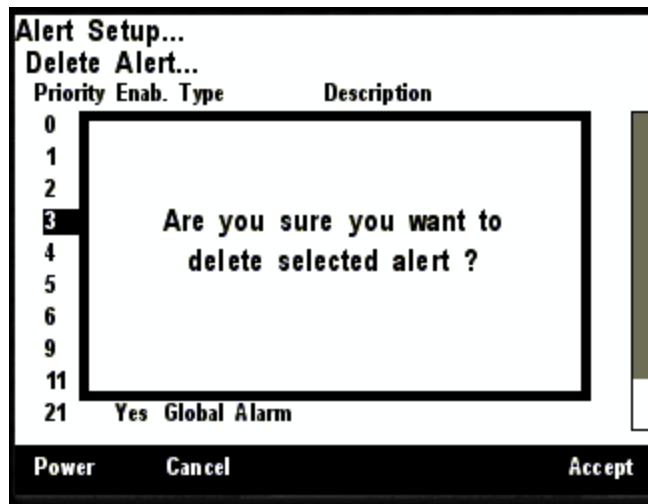


This brings up the list of Alerts managed by the DSM2590.



Scroll up and down using the **Scroll Up** and **Scroll Down** buttons until the alert that must be deleted is highlighted, and press the **Enter** button.

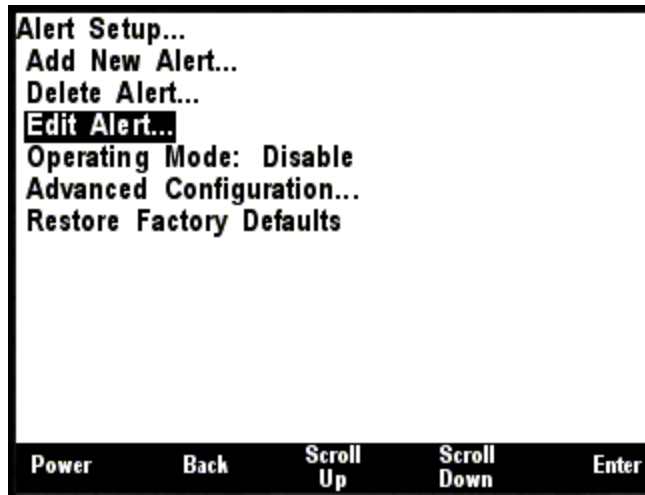
A confirmation message is displayed.



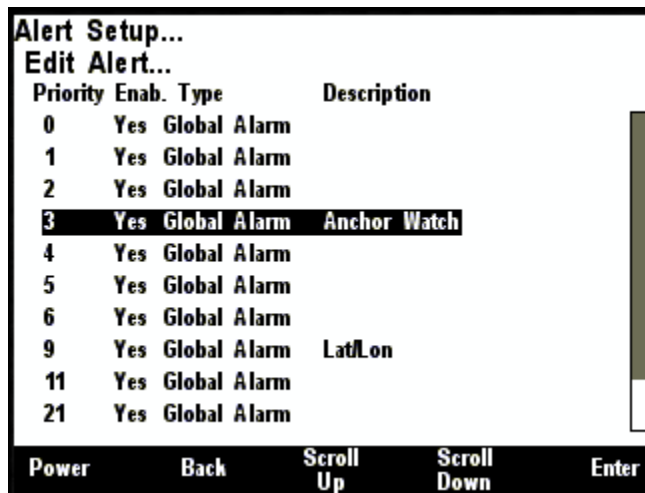
Press the **Accept** button to delete the Alert or the **Cancel** button to return to the previous screen without deleting the Alert.

## 8.5 Editing an Alert

From the **Alert Setup Menu**, selected the menu item **Edit Alert...** .



This brings up the list of Alerts managed by the DSM2590.



The following information is shown for each alert that is in the system.

**Priority** – The priority of the Alert (see 8.3.3).

**Enab.** – Whether the Alert is Enabled or Disabled.

**Type** – The Type of Alert. This is a combination of whether the Alert is Local or Global (0) and whether the Alert is an Alarm or a Warning (8.3.2)

**Description** – The textual description of the Alert (8.3.5)

Scroll up and down using the **Scroll Up** and **Scroll Down** buttons until the alert that must be edited is highlighted, and press the **Enter** button.

The Alert Editor is opened, pre-populated with the parameters of the chosen Alert. See section 8.1 for details of these parameters.

## 8.6 Setting the Vessel Operating Mode

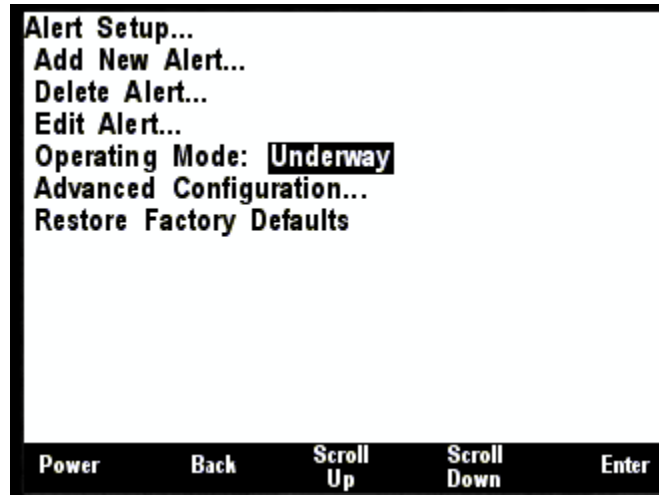
The Vessel Operating Mode must be set on each DSM250. This is a potentially risky operation, in that Alerts that are Active in the existing mode may be ignored in the new Operating Mode. The DSM250 will warn the operator about these Alerts to minimize the risk. However, if the new vessel

# DSM250 User's Manual

---

status was transmitted to other Alert Sources that are unmanned, then the warnings would be lost. For this reason, the Vessel Operating mode must be changed at each DSM250 or N2Kview, and those alerts, which would be disabled, noted by the user.

The Vessel Operating Mode is set through the Alert Setup Screen. **Scroll Down** to the required Operating Mode entry, press **Enter** and then use the **Scroll Up** / **Scroll Down** buttons to select the new Mode. Press **Enter** to complete the operation.

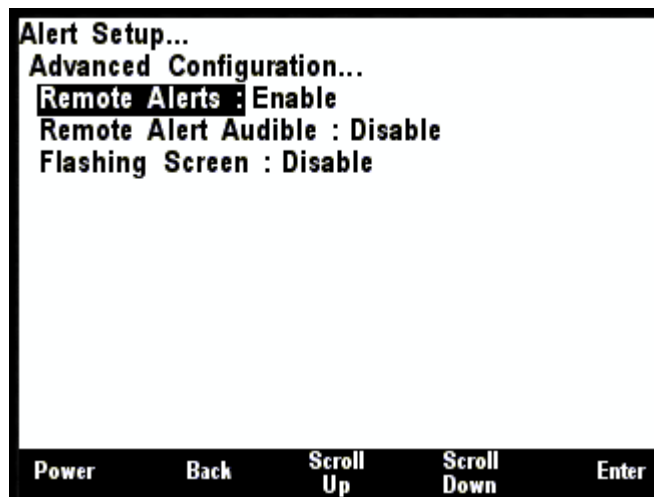


The options here are

- Disable
- Moored
- Anchored
- Underway

## 8.7 Advanced Configuration

The Advanced Parameters of the Alert System may be configured through this Screen. Enter the screen through the **Alert Setup** menu, and select the **Advanced Configuration** option.



The following parameters may be set.

## 8.7.1 Remote Alerts

The DSM250 may be set up to not respond to Alerts generated by other devices on the bus. This is a global setting and will apply to all Remote Alerts from all other devices. The options here are

- Enable
- Disable

## 8.7.2 Remote Alert Audible

If Remote Alerts are enabled, and an active alert is received from another device on the bus, the DSM250 will respond by adding the Alert to its list of Active Alerts (section 8.1), and sounding the internal speaker. The sounding of the speaker may be disabled (i.e. only visual indications are displayed) by setting this parameter to Disable. The options here are

- Enable
- Disable

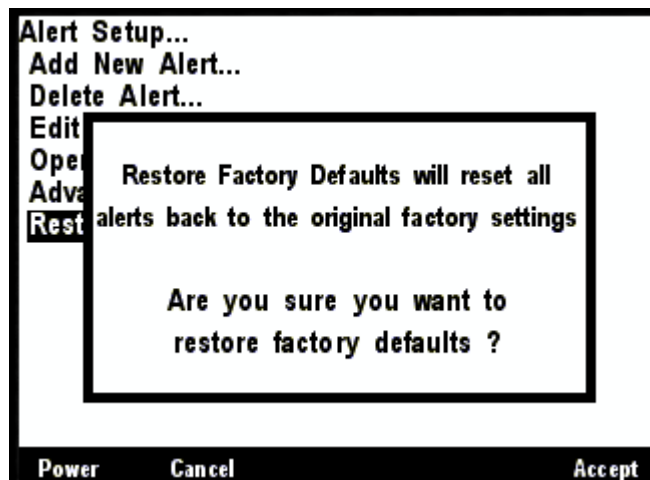
## 8.7.3 Flashing Screen

As an extra means to gain the operator's attention to an Active Alert, the DSM250 may be set up to flash the entire screen between Red (for Alarms) or Yellow (for Warnings) and Black. The flashing may be disabled by setting this option to Disable. The options here are

- Enable
- Disable

## 8.8 Restore Factory Defaults

The Alert parameters of the DSM250 may be restored to the factory defaults by pressing the Enter button while this item is highlighted. The operator will be prompted to confirm this action before it taken.



## 9 Maintenance

Regular maintenance is important to ensure continued proper operation of the Maretron DSM250. Perform the following tasks periodically:

- Clean the unit with a soft cloth. Do not use chemical cleaners as they may remove paint or markings or may corrode the DSM250 enclosure or seals.
- Ensure that the unit is mounted securely and cannot be moved relative to the mounting surface. If the unit is loose, tighten the mounting screws.
- Check the security of the cable connected to the NMEA 2000<sup>®</sup> interface and tighten if necessary.



## 10 Troubleshooting

If you notice unexpected operation of the Maretron DSM250, follow the troubleshooting procedures in this section to remedy simple problems.

Symptom	Troubleshooting Procedure
No activity on the display	Check the connection to the NMEA 2000 <sup>®</sup> and connector and tighten if necessary Ensure that power is supplied to the connected NMEA 2000 <sup>®</sup> cable
Expected data appears as a dash “-“ instead of a value	
Data fluctuates between two different values	Two devices on the network are transmitting the same data. Check the Instance Numbers on all devices transmitting that data.

If these steps do not solve your problem, please contact Maretron Technical Support (refer to Section 12 for contact information).

*Warning: There are no user-serviceable components inside the Maretron DSM250. Opening the DSM250 will expose the sensitive electronic components to adverse environmental conditions that may render the unit inoperative. Please do not open the DSM250, as this will automatically void the warranty. If service is required, please return the unit to an authorized Maretron service location.*



## 11 Technical Specifications

### Specifications

Parameter	Value	Comment
NMEA 2000 <sup>®</sup> Standard	Level A	Highest Level of Certification
NMEA 2000 <sup>®</sup> Connector	DeviceNet Micro-C	Industry Standard Waterproof
Display Technology	Active Matrix TFT LCD	Sunlight Readable
Display Resolution	320 x 240 Pixels	QVGA Resolution
Display Viewable Area	117mm W x 88 mm H	5.7" Diagonal
Display Backlighting	CCFL	3 User-Programmed Levels 0-100%
Keyboard	5 Silicone Rubber Keys	Red LED Backlighting
Languages Supported	English, Dutch (Nederlands)	User Selectable

### Certifications

Parameter	Comment
NMEA 2000 <sup>®</sup>	Level A
Maritime Navigation and Radiocommunication Equipment & Systems	Tested to IEC 60945
FCC and CE Mark	Electromagnetic Compatibility

### Supported Display Data Types

Description	Data Types
AC Power	Voltage, Current, Frequency
Battery Monitor	Voltage, Current, Temperature
Depth	Water Depth, Transducer Offset
Engine Monitor	Oil & Coolant Pres & Temp, Fuel Rate, Hours, Fuel Pres, Tilt/Trim, RPM, Boost Pres. Voltage
Environment	Barometer, Heat Index, Humidity In & Out, Moon Phase, Sunrise, Sunset, Temp Dew Point, Cabin Temps, Sea Temp, Twilight am & pm, Weather, Wind Chill
Fuel Management	Total Fuel Rate, Total Fuel Remaining, Total Fuel Economy
GPS	COG, SOG, Lat/Lon, DOP, Position, Satellites, Time
Heading	Vessel Heading, Rate of Turn, Variation
Navigation	BTW, DTW, ETA, TTG, XTE, Datum, Set & Drift, Waypoint Number & Name, VMG, BOD, Set, Drift, Rolling Road
Rudder	Rudder Angle
Speed	Total Log, Trip Log, Speed Through Water
Tanks	Fluid Level, Tank Capacity, Amount Remaining
Time	Local & UTC Time & Date, Sunrise, Sunset, Twilight AM, Twilight PM, Moon Phase
Transmission	Gear, Oil Temperature and Pressure
Vessel	Pitch, Roll, Trim Tabs, Keel

# DSM250 User's Manual

Wind	Apparent & True Wind Direction and Speed, Ground Referenced Speed and Direction
------	---

## NMEA 2000® Parameter Group Numbers (PGNs)

Description	PGN #	PGN Name	Default Rate
Response to Requested PGNs	126464	PGN List (Transmit and Receive)	N/A
	126996	Product Information	N/A
	126998	Configuration Information	N/A
Protocol PGNs	059392	ISO Acknowledge	N/A
	059904	ISO Request	N/A
	060160	ISO Transport Protocol, Data Transfer	N/A
	060416	ISO Transport Protocol, Connection Management	N/A
	060928	ISO Address Claim	N/A
	065240	ISO Address Command	N/A
	126208	NMEA	N/A
Received PGNs	065030	Generator Average Basic AC Quantities	NA
	126992	System Time	N/A
	127245	Rudder	N/A
	127250	Vessel Heading	N/A
	127251	Rate of Turn	N/A
	127257	Attitude	N/A
	127258	Magnetic Variation	N/A
	127488	Engine Parameters, Rapid Update	N/A
	127489	Engine Parameters, Dynamic	N/A
	127493	Transmission Parameters, Dynamic	N/A
	127498	Engine Parameters, Static	N/A
	127505	Fluid Level	N/A
	127508	Battery Status	N/A
	128259	Speed	N/A
	128267	Water Depth	N/A
	128275	Distance Log	N/A
	129025	Position, Rapid Update	N/A
	129026	COG & SOG, Rapid Update	N/A
	129029	GNSS Position Data	N/A
	129033	Time & Date	N/A
	129283	Cross Track Error	N/A
	129284	Navigation Data	N/A
	129285	Navigation – Route/WP Information	N/A
	129291	Set & Drift, Rapid Update	N/A
	129302	Bearing and Distance Between Two Marks	N/A
	129538	GNSS Control Status	N/A
	129539	GNSS DOPs	N/A
	129540	GNSS Sats In View	N/A
	130306	Wind Data	N/A
	130310	Environmental Parameters	N/A
	130311	Environmental Parameters	N/A

	130576	Small Craft Status	N/A
--	--------	--------------------	-----

## Electrical

Parameter	Value	Comment
Operating Voltage	9 to 16 Volts	DC Voltage
Power Consumption (Maximum)	<650mA	Low Supply, Full Brightness
	<200mA	Nominal Supply, Low Brightness
Load Equivalence Number (LEN)	13	NMEA 2000® Spec. (1LEN = 50 mA)
Reverse Battery Protection	Yes	Indefinitely
Load Dump Protection	Yes	Energy Rated per SAE J1113

## Mechanical

Parameter	Value	Comment
Size	6.875" x 5.75" x 1.75"	Including Flanges for Mounting
Weight	26 oz.	
Mounting	Surface or Flush Mount	

## Environmental

Parameter	Value
IEC 60954 Classification	Exposed
Degree of Protection	IP67
Operating Temperature	-25°C to 55°C
Storage Temperature	-40°C to 70°C
Relative Humidity	93%RH @40° per IEC60945-8.2
Vibration	2-13.2Hz @ ±1mm, 13.2-100Hz @ 7m/s <sup>2</sup> per IEC 60945-8.7
Rain and Spray	12.5mm Nozzle @ 100liters/min from 3m for 30min per IEC 60945-8.8
Solar Radiation	Ultraviolet B, A, Visible, and Infrared per IEC 60945-8.10
Corrosion (Salt Mist)	4 times 7days @ 40°C, 95%RH after 2 hour Salt Spray Per IEC 60945-8.12
Electromagnetic Emission	Conducted and Radiated Emission per IEC60945-9
Electromagnetic Immunity	Conducted, Radiated, Supply, and ESD per IEC 60945-10
Safety Precautions	Dangerous Voltage, Electromagnetic Radio Frequency per IEC 60945-12



## 12 Technical Support

If you require technical support for Maretron products, you can reach us in any of the following ways:

Telephone: 1-866-550-9100

Fax: 1-602-861-1777

E-mail: [support@maretron.com](mailto:support@maretron.com)

World Wide Web: <http://www.maretron.com>

Mail: Maretron, LLP

Attn: Technical Support

9014 N. 23<sup>rd</sup> Ave Suite 10

Phoenix, AZ 85021 USA



### 13 Installation Template

Please check the dimensions before using the following diagram as a template for drilling the mounting holes because the printing process may have distorted the template.

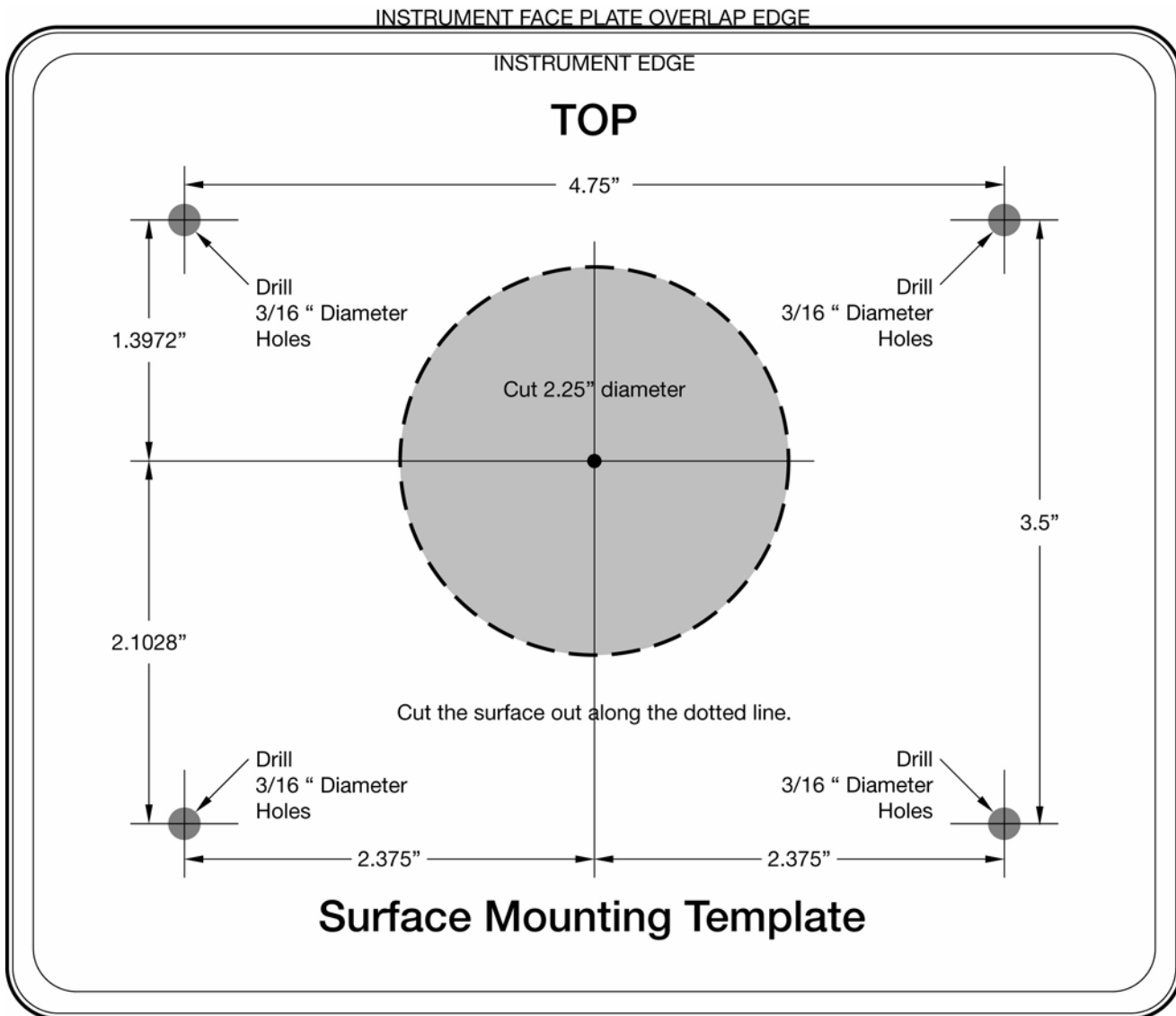
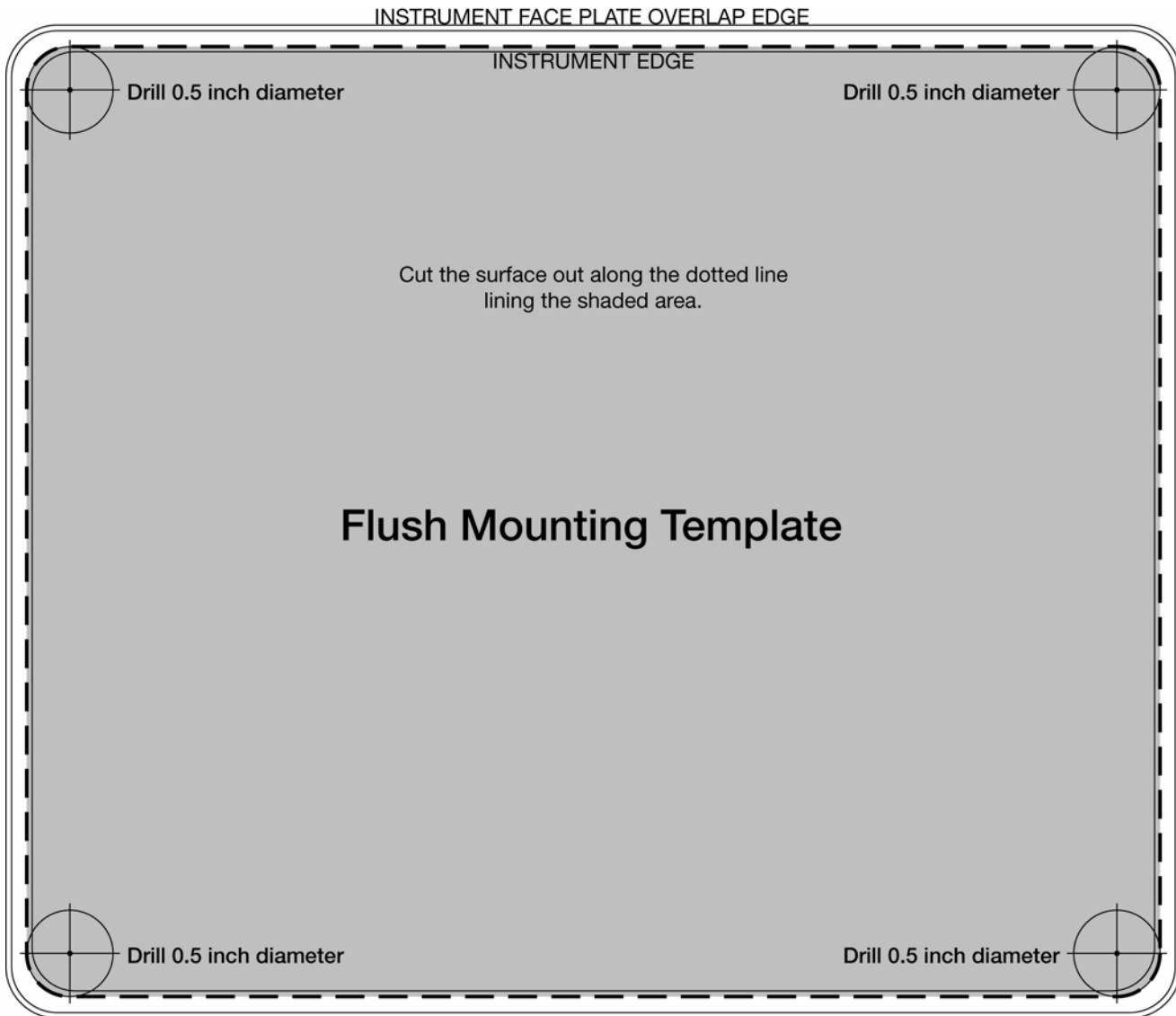


Figure 200 – Surface Mounting Template



**Figure 201 – Flush Mounting Template**





## 14 Maretron (2 Year) Limited Warranty

Maretron warrants the DSM250 to be free from defects in materials and workmanship for two (2) years from the date of original purchase. If within the applicable period any such products shall be proved to Maretron's satisfaction to fail to meet the above limited warranty, such products shall be repaired or replaced at Maretron's option. Purchaser's exclusive remedy and Maretron's sole obligation hereunder, provided product is returned pursuant to the return requirements below, shall be limited to the repair or replacement, at Maretron's option, of any product not meeting the above limited warranty and which is returned to Maretron; or if Maretron is unable to deliver a replacement that is free from defects in materials or workmanship, Purchaser's payment for such product will be refunded. Maretron assumes no liability whatsoever for expenses of removing any defective product or part or for installing the repaired product or part or a replacement therefore or for any loss or damage to equipment in connection with which Maretron's products or parts shall be used. With respect to products not manufactured by Maretron, Maretron's warranty obligation shall in all respects conform to and be limited to the warranty actually extended to Maretron by its supplier. The foregoing warranties shall not apply with respect to products subjected to negligence, misuse, misapplication, accident, damages by circumstances beyond Maretron's control, to improper installation, operation, maintenance, or storage, or to other than normal use or service.

THE FOREGOING WARRANTIES ARE EXPRESSLY IN LIEU OF AND EXCLUDES ALL OTHER EXPRESS OR IMPLIED WARRANTIES, INCLUDING BUT NOT LIMITED TO THE IMPLIED WARRANTIES OF MERCHANTABILITY AND OF FITNESS FOR A PARTICULAR PURPOSE.

Statements made by any person, including representatives of Maretron, which are inconsistent or in conflict with the terms of this Limited Warranty, shall not be binding upon Maretron unless reduced to writing and approved by an officer of Maretron.

IN NO CASE WILL MARETRON BE LIABLE FOR INCIDENTAL OR CONSEQUENTIAL DAMAGES, DAMAGES FOR LOSS OF USE, LOSS OF ANTICIPATED PROFITS OR SAVINGS, OR ANY OTHER LOSS INCURRED BECAUSE OF INTERRUPTION OF SERVICE. IN NO EVENT SHALL MARETRON'S AGGREGATE LIABILITY EXCEED THE PURCHASE PRICE OF THE PRODUCT(S) INVOLVED. MARETRON SHALL NOT BE SUBJECT TO ANY OTHER OBLIGATIONS OR LIABILITIES, WHETHER ARISING OUT OF BREACH OF CONTRACT OR WARRANTY, TORT (INCLUDING NEGLIGENCE), OR OTHER THEORIES OF LAW WITH RESPECT TO PRODUCTS SOLD OR SERVICES RENDERED BY MARETRON, OR ANY UNDERTAKINGS, ACTS OR OMISSIONS RELATING THERETO.

Maretron does not warrant that the functions contained in any software programs or products will meet purchaser's requirements or that the operation of the software programs or products will be uninterrupted or error free. Purchaser assumes responsibility for the selection of the software programs or products to achieve the intended results, and for the installation, use and results obtained from said programs or products. No specifications, samples, descriptions, or illustrations provided Maretron to Purchaser, whether directly, in trade literature, brochures or other documentation shall be construed as warranties of any kind, and any failure to conform with such specifications, samples, descriptions, or illustrations shall not constitute any breach of Maretron's limited warranty.

Warranty Return Procedure:

To apply for warranty claims, contact Maretron or one of its dealers to describe the problem and determine the appropriate course of action. If a return is necessary, place the product in its original packaging together with proof of purchase and send to an Authorized Maretron Service Location. You are responsible for all shipping and insurance charges. Maretron will return the replaced or repaired product with all shipping and handling prepaid except for requests requiring expedited shipping (i.e. overnight shipments). Failure to follow this warranty return procedure could result in the product's warranty becoming null and void.

Maretron reserves the right to modify or replace, at its sole discretion, without prior notification, the warranty listed above. To obtain a copy of the then current warranty policy, please go to the following web page:

<http://www.maretron.com/company/warranty.php>