

# OWNER'S GUIDE & INSTALLATION INSTRUCTIONS

## Thru-Hull, Retractable TRIDUCER® Multisensor

Model DST800

U.S. Patents: 6,904,798; 7,110,908; 7,352,171. UK Patents: 2 407 874; 2 409 527

12/14/10

17-355-01 rev. 06

**WARNING:** Always wear safety goggles and a dust mask when installing to avoid personal injury.

**WARNING:** The O-rings must be intact and well lubricated to make a watertight seal.

**WARNING:** Always attach the safety wire to prevent the insert or blanking plug from backing out in the unlikely event that the cap nut fails or is screwed on incorrectly.

**WARNING:** Immediately check for leaks when the boat is placed in the water. Do not leave the boat unchecked for more than three hours. Even a small leak may allow considerable water to accumulate.

**WARNING:** Stainless steel housing in a metal hull—Be sure the washer contacts the hull. Do not tighten the hull nut with the washer against the isolation bushing, as the housing will not be firmly installed. If necessary, sand the isolation bushing until the washer rests against the hull.

**CAUTION:** Never install a metal multisensor on a vessel with a positive ground system.

**CAUTION:** Never use a fairing with a plastic housing; the protruding sensor would be vulnerable to damage from impact.

**CAUTION:** Never pull, carry, or hold the multisensor by its cable; this may sever internal connections.

**CAUTION:** Never use solvents. Cleaners, fuel, sealants, paint, and other products may contain strong solvents, such as acetone, which attack many plastics, greatly reducing their strength.

**CAUTION:** Stainless steel housing must be isolated from a metal hull to prevent electrolytic corrosion. Use the isolation bushing supplied.

**IMPORTANT:** Read the instructions completely before proceeding with the installation. These instructions supersede any other instructions in your instrument manual if they differ.

## Pretest

Connect the multisensor to the instrument and spin the paddlewheel. Check for a speed reading and the approximate air temperature. If there are no readings or they are inaccurate, check all the connections and repeat the test. If there are still no readings or they are inaccurate, return the product to the place of purchase.

Record the information found on the cable tag for future reference.

Part No. \_\_\_\_\_ Date \_\_\_\_\_ Frequency \_\_\_\_\_ kHz

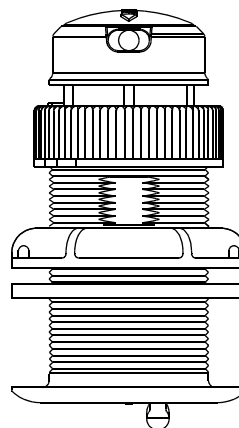

plastic  
low profile  
P17 housing

## Applications

- **Plastic** housing recommended for fiberglass or metal hull only. *Never* install a plastic housing in a wood hull since swelling of the wood may overstress the plastic causing a fracture.
- **Bronze** housing recommended for fiberglass or wood hull. *Never* mount a bronze housing in an aluminum hull because electrolytic corrosion will occur.
- **Stainless steel** housing compatible with all hull materials. Recommended for aluminum hull to prevent electrolytic corrosion *provided the stainless steel housing is isolated from the metal hull.*
- Accommodates up to 22° deadrise angle

## Tools & Materials

Safety goggles

Dust mask

Water-based anti-fouling paint (**mandatory in salt water**)

Electric drill with 10mm (3/8") or larger chuck capacity

Drill bit: 3mm *or* 1/8"

Hole saw: 51mm *or* 2" (plastic or metal housing in non-metal hull)

57mm *or* 2-1/4" (stainless steel housing in a metal hull)

Countersink tool (installing a flush housing)

Sandpaper

Mild household detergent *or* weak solvent (such as alcohol)

File (installation in a metal hull)

Marine sealant (suitable for below waterline)

Additional washer [for aluminum hull less than 6mm (1/4") thick]

Slip-joint pliers (installing a bronze housing)

Grommet(s) (some installations)

Cable ties

Installation in a cored fiberglass hull (see page 3):

Hole saw for hull interior: 60mm *or* 2-3/8"

Fiberglass cloth and resin

*or* Cylinder, wax, tape, and casting epoxy

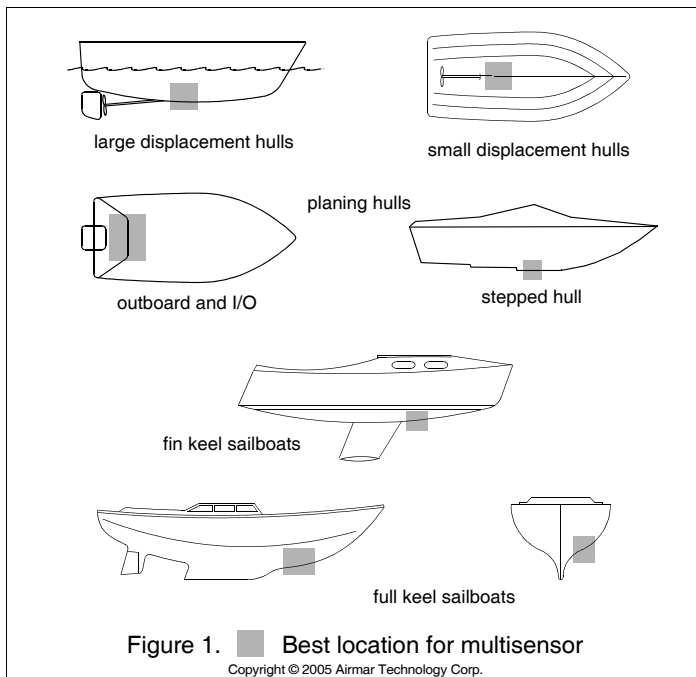

## Mounting Location

**CAUTION:** Do not mount near water intake or discharge openings, or behind strakes, fittings, or hull irregularities.

- The water flowing under the hull must be smooth with a minimum of bubbles and turbulence (especially at high speeds).
- The multisensor must be continuously immersed in water.
- The transducer beam must be unobstructed by the keel or propeller shaft(s).
- Choose a location away from interference caused by power and radiation sources such as: the propeller(s) and shaft(s), other machinery, other echosounders, and other cables. The lower the noise level, the higher the echosounder gain setting that can be used.
- Choose a location with a minimal deadrise angle, so the transducer beam will be aimed at the bottom.
- Choose an accessible spot inside the vessel with adequate headroom for the height of the housing, tightening the nuts, and removing the insert. Allow a minimum of 280mm (11").

## Hull Types (see Figure 1)

- **Displacement hull powerboats**—Locate amidships near the centerline. The starboard side of the hull where the propeller blades are moving downward is preferred.
- **Planing hull powerboats**—Mount well aft, on or near the centerline, and well inboard of the first set of lifting strakes to insure that the multisensor will be in contact with the water at high speeds. The starboard side of the hull where the propeller blades are moving downward is preferred.
- **Outboard and I/O**—Mount just forward of the engine(s).
- **Inboard**—Mount well ahead of the propeller(s) and shaft(s).
- **Stepped hull**—Mount just ahead of the first step.
- **Boat capable of speeds above 25 kn (29MPH)**—Review the installation location and operating results of similar boats before proceeding.
- **Fin keel sailboats**—Mount on or near the centerline and forward of the fin keel 300–600mm (1–2').
- **Full keel sailboats**—Locate amidships and away from the keel at the point of minimum deadrise.

## Anti-fouling Paint

Aquatic growth can accumulate rapidly on the multisensor's surface reducing performance within weeks. Surfaces exposed to salt water must be coated with anti-fouling paint. Use water-based anti-fouling paint only. Never use ketone-based paint, since ketones can attack many plastics possibly damaging the sensor.

It is easier to apply anti-fouling paint before installation, but allow sufficient drying time. Reapply paint every 6 months or at the beginning of each boating season. Paint the following surfaces ( Figure 2):

- Outside wall of the insert below the lower O-ring
- Paddlewheel cavity
- Paddlewheel
- Exposed end of the insert
- Exterior flange of the housing
- Bore of the housing up 30mm (1-1/4")
- Blanking plug below the lower O-ring including the exposed end

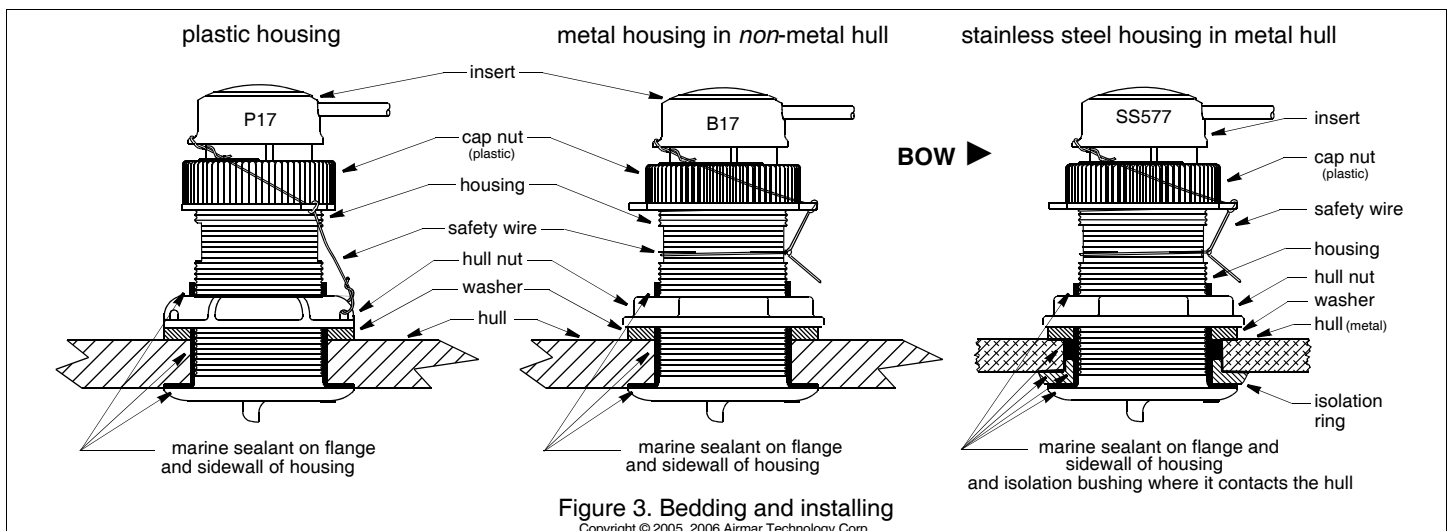
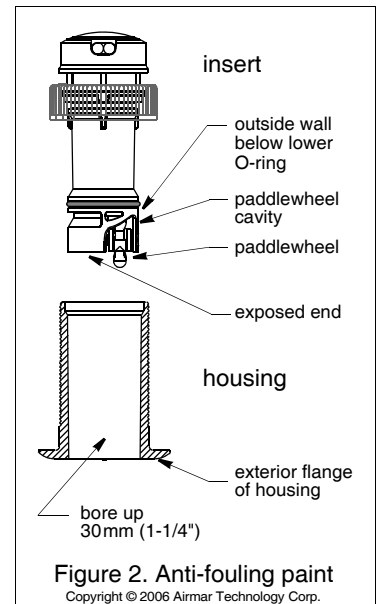

## Installation

### Hole Drilling

**Cored fiberglass hull**—Follow separate instructions on page 3.

1. Drill a 3mm or 1/8" pilot hole from inside the hull. If there is a rib, strut or other hull irregularity near the selected mounting location, drill from the outside.

2. Using the appropriate size hole saw, cut a hole perpendicular to the hull from outside the boat.

**Flush housing**—Use a countersink tool to make a “seat” in the hull.

3. Sand and clean the area around the hole, inside and outside, to ensure that the sealant will adhere properly to the hull. If there is any petroleum residue inside the hull, remove it with either mild household detergent or a weak solvent (alcohol) before sanding.

**Metal hull**—Remove all burrs with a file and sandpaper.

### Bedding

**CAUTION:** Be sure the surfaces to be bedded are clean and dry.

Apply a 2mm (1/16") thick layer of marine sealant around the flange of the housing that will contact the hull and up the sidewall of the housing (see Figure 3). *The sealant must extend 6mm (1/4") higher than the combined thickness of the hull, the washer(s), and the hull nut.* This will ensure there is marine sealant in the threads to seal the hull and to hold the hull nut securely in place.

**Stainless steel housing in a metal hull**—The stainless steel housing must be isolated from the metal hull to prevent electrolytic corrosion. Slide the isolation bushing onto the housing. Apply *additional* sealant to the surfaces of the bushing that will contact the hull, filling any cavities in and around the bushing.

### Installing

**CAUTION:** If your multisensor came with a connector, do not remove it to ease cable routing. If the cable must be cut and spliced, use Airmar’s splash-proof Junction Box No. 33-035 and follow the instructions provided. Removing the waterproof connector or cutting the cable, except when using a water-tight junction box, will void the sensor warranty.

1. From outside the hull, push the housing into the mounting hole using a twisting motion to squeeze out excess marine sealant (see Figure 3). *Align the arrow on the flange of the housing to point forward toward the bow.* If the multisensor is not installed on the centerline of the boat, angle the housing slightly toward the centerline to align it with the water flow.

2. From inside the hull, slide the washer onto the housing.

**Aluminum hull less than 6mm (1/4") thick**—Use an additional rubbery, fiberglass, or plastic washer. Never use bronze since electrolytic corrosion will occur. Never use wood since it will swell, possibly fracturing the plastic housing.

**Stainless steel housing in a metal hull**—Be sure the washer contacts the hull. Do not tighten the hull nut with the washer against the isolation bushing as the housing will not be firmly installed. If necessary, sand the isolation bushing until the washer rests against the hull.

3. Screw the hull nut in place being sure the arrow on the flange of the housing is still positioned forward toward the bow.

**Plastic housing**—Do not clamp tightly on the wrenching flats, possibly causing the housing to fracture.

**Plastic hull nut**—**Hand tighten** only. Do not over tighten.

**Metal hull nut**—Tighten with slip-joint pliers.

**Cored Fiberglass Hull**—Do not over tighten, crushing the hull.

**Wood hull**—Allow the wood to swell before tightening the nut.

4. Remove any excess marine sealant on the outside of the hull to ensure smooth water flow over the multisensor.

5. After the marine sealant cures, inspect the O-rings on the insert (replace if necessary) and lubricate them with the silicone lubricant supplied. The O-rings must be intact and well lubricated to make a watertight seal.

6. Slide the paddlewheel insert into the housing with the *arrow on the top pointing forward toward the bow.* Be sure the insert is fully inserted into the housing. Screw the cap nut several turns until the threads are engaged. The arrow on the top of the insert, the cable exit, and the arrow on the housing flange will all be aligned. Continue to tighten the cap nut completely for a watertight seal. Be careful not to rotate the housing and disturb the sealant. **Hand tighten** only. Do not over tighten.

7. Always attach the safety wire to prevent the insert from backing out in the unlikely event that the cap nut fails or is screwed on incorrectly.

**Plastic housing**—Attach the safety wire to one eye in the hull nut. Keeping the wire taut throughout, lead the wire in a counterclockwise direction and thread it through one eye in the cap nut. Thread the wire through the eye a second time. Then lead the wire through the eye in the insert. Twist the wire securely to itself.

**Metal housing**—Wrap one end of the safety wire tightly around the housing and twist it together with the long end. Keeping the wire taut throughout, lead the wire straight up and through one eye in the cap nut. Thread the wire through the eye a second time. Then lead the wire counterclockwise and through the eye in the insert. Twist the wire securely to itself.

8. Route the cable to the instrument being careful not to tear the cable jacket when passing it through the bulkhead(s) and other parts of the boat. Use grommet(s) to prevent chaffing. To reduce electrical interference, separate the multisensor cable from other electrical wiring and the engine. Coil any excess cable and secure it in place with cable ties to prevent damage.

9. Refer to the instrument owner’s manual to connect the multisensor to the instrument.

## Checking for Leaks

When the boat is placed in the water, **immediately** check around the thru-hull multisensor for leaks. Note that very small leaks may not be readily observed. Do not leave the boat in the water for more than 3 hours before checking it again. If there is a small leak, there may be considerable bilge water accumulation after 24 hours. If a leak is observed, repeat “Bedding” and “Installing” **immediately** (see page 3).

## Installation in a Cored Fiberglass Hull

The core (wood or foam) must be cut and sealed carefully. The core must be protected from water seepage, and the hull must be reinforced to prevent it from crushing under the hull nut allowing the housing to become loose.

**CAUTION:** Completely seal the hull to prevent water seepage into the core.

1. Drill a 3mm or 1/8" pilot hole from inside the hull. If there is a rib, strut, or other hull irregularity near the selected mounting location, drill from the outside. (If the hole is drilled in the wrong location, drill a second hole in a better location. Apply masking tape to the outside of the hull over the incorrect hole and fill it with epoxy.)

2. Using a 51 mm or 2" hole saw, cut the hole from outside the hull through the *outer* skin only (see Figure 4).

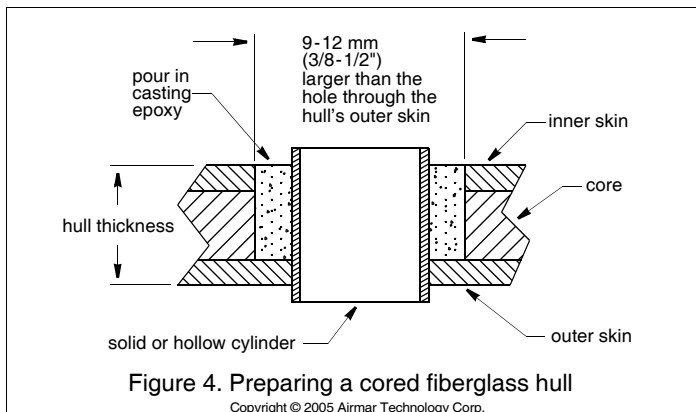

Figure 4. Preparing a cored fiberglass hull

Copyright © 2005 Airmar Technology Corp.

- From inside the hull, use a 60mm or 2-3/8" hole saw to cut through the *inner* skin and most of the core. The core material can be very soft. Apply only light pressure to the hole saw after cutting through the inner skin to avoid accidentally cutting the *outer* skin.
- Remove the plug of core material so the *inside* of the outer skin and the inner core of the hull are fully exposed. Sand and clean the inner skin, core, and the outer skin around the hole.
- If you are skilled with fiberglass, saturate a layer of fiberglass cloth with a suitable resin and lay it inside the hole to seal and strengthen the core. Add layers until the hole is the correct diameter. Alternatively, a hollow or solid cylinder of the correct diameter can be coated with wax and taped in place. Fill the gap between the cylinder and hull with casting epoxy. After the epoxy has set, remove the cylinder.
- Sand and clean the area around the hole, inside and outside, to ensure that the marine sealant will adhere properly to the hull. If there is any petroleum residue inside the hull, remove it with either mild household detergent or a weak solvent (alcohol) before sanding.
- Proceed with "Bedding" and "Installing" on page 3.

## Maintenance, Parts & Replacement

### Using the Blanking Plug

To protect the paddlewheel, use the blanking plug:

- When the boat will be kept in salt water for more than a week.
  - When the boat will be removed from the water.
  - When aquatic growth buildup on the paddlewheel is suspected due to inaccurate readings from the instrument.
- The O-rings must be intact and well lubricated to make a watertight seal. On the blanking plug, inspect the O-rings (replace if necessary) and lubricate them with the silicone lubricant supplied or petroleum jelly (Vaseline®) (see Figure 5).
  - Remove the insert from the housing by removing the safety wire and unscrewing the cap nut (see Figure 3). This will jack out the insert.
  - With the blanking plug ready in one hand, pull the insert most of the way out. Remove the insert and rapidly replace it with the blanking plug. With practice, only 250ml (10oz.) of water will enter the boat. Be sure the blanking plug is fully inserted into the housing.
  - Screw the cap nut several turns until the threads are engaged. Continue to tighten the cap nut completely for a watertight seal. **Hand tighten** only. Do not over tighten.
  - Reattach the safety wire to prevent the blanking plug from backing out in the unlikely event that the cap nut fails or is screwed on incorrectly.

### Servicing the Insert

Aquatic growth can accumulate rapidly on the depth transducer's surface and impede or freeze the paddlewheel's rotation reducing performance within weeks. Clean the insert with a Scotch-Brite® scour pad and mild household detergent, being careful to avoid scratching the depth

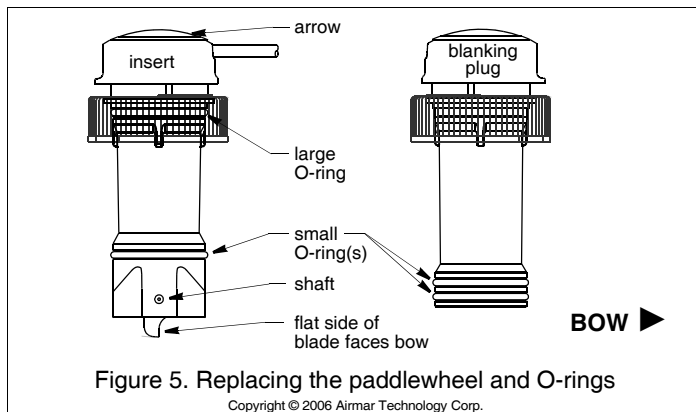

Figure 5. Replacing the paddlewheel and O-rings

Copyright © 2006 Airmar Technology Corp.

transducer. If fouling is severe, remove the paddlewheel (see step #1 below). Lightly wet sand it with fine grade wet/dry paper.

The water lubricated paddlewheel bearings have a life of up to 5 years on low-speed boats [less than 10kn (11MPH)] and 1 year on high-speed vessels. Paddlewheels can fracture and shafts can bend due to impact with water borne objects and mishandling in boat yards. O-rings must be free of abrasions and cuts to ensure a watertight seal. Order a replacement Paddlewheel Kit 33-398-04.

- To remove the old paddlewheel shaft, grasp the end with small diagonal wire cutters and pull (see Figure 5).
- Place the new paddlewheel in the cavity with the flat side of the blade facing the same direction as the arrow on the top of the insert.
- Tap the new shaft into place until the end is flush with the outside wall of the insert.
- Install a large O-ring near the top of the insert. Install a small O-ring near the paddlewheel.
- Place the remaining two O-rings on the blanking plug near the bottom.

### Winterizing

After the boat has been hauled for winter storage, remove the blanking plug to let the water drain away before reinserting it. This will prevent any water from freezing around the blanking plug and possibly cracking it.

### Replacement Multisensor & Parts

The information needed to order a replacement Airmar multisensor is printed on the cable tag. Do not remove this tag. When ordering, specify the part number, date, and frequency in kHz. For convenient reference, record this information on the top of page one.

Lost, broken, or worn parts should be replaced immediately. If you have purchased a plastic housing and have a wood hull or desire greater strength, purchase an Airmar metal housing.

Blanking Plug	Hull Nut or Isolation Bushing	Paddlewheel, Shaft & O-rings	Housing, Nut & Washer
33-538-01	04-004 (plastic) 02-030 (bronze) 02-570-01 (stainless steel) 04-186-1 (isolation bushing)	33-398-04	33-417 (plastic, P17) 33-100 (bronze, B17) 33-495-01 (stainless steel SS577)

Obtain parts from your instrument manufacturer or marine dealer.

Gemeco  
(USA)

Tel: 803.693.0777  
Fax: 803.693.0477  
email: sales@gemeco.com

Airmar EMEA  
(Europe, Middle East, Africa)

Tel: +33.(0)2.23.52.06.48  
Fax: +33.(0)2.23.52.06.49  
email: sales@airmar-emea.com

**AIRMAR**®  
TECHNOLOGY CORPORATION

35 Meadowbrook Drive, Milford, New Hampshire 03055-4613, USA

www.airmar.com