



Raymarine 33STV Satellite Television System

US Version
User's Guide

Raymarine®

Trademarks and registered trademarks

Autohelm, HSB, RayTech Navigator, Sail Pilot, SeaTalk and Sportpilot are UK registered trademarks of Raymarine UK Limited. Pathfinder and Raymarine are UK registered trademarks of Raymarine Holdings Limited. 33STV, 45STV, 60STV, AST, Autoadapt, Auto GST, AutoSeastate, AutoTrim, Bidata, G Series, HDFI, LifeTag, Marine Intelligence, Maxiview, On Board, Raychart, Raynav, Raypilot, RayTalk, Raystar, ST40, ST60+, Seaclutter, Smart Route, Tridata, UniControl, Hybridtouch, and Waypoint Navigation are trademarks of Raymarine UK Limited.

All other product names are trademarks or registered trademarks of their respective owners.

Copyright ©2009 Raymarine UK Ltd. All rights reserved.

ENGLISH

Document number: 81325-1

Date: 09-2009

Contents

Chapter 1 Introduction	7	5.2 Satellite coverage	46
Safety notices.....	7	5.3 Satellite providers	47
Important information	7	5.4 Satellite tracking data	49
Chapter 2 Installation	11	Chapter 6 Technical Specification	55
2.1 Preparation.....	12	6.1 Technical specification.....	56
2.2 Procedures.....	18		
Chapter 3 System operation & setup.....	25		
3.1 Introduction.....	26		
3.2 Getting started	26		
3.3 Setup using the ACU.....	28		
3.4 Applying factory default values.....	37		
3.5 System information	37		
3.6 Checking system power.....	38		
3.7 Skew angle.....	38		
3.8 Graphical user interface.....	39		
Chapter 4 Maintenance & troubleshooting	41		
4.1 Maintenance	42		
4.2 Troubleshooting	42		
4.3 Raymarine technical support.....	44		
Chapter 5 Satellite information	45		
5.1 Introduction.....	46		

Chapter 1: Introduction

Safety notices



Warning: Product installation and operation

This product must be installed and operated in accordance with the Raymarine instructions provided. Failure to do so could result in personal injury, damage to your boat and/or poor product performance.

Caution: Power supply protection

When installing this product ensure the power source is adequately protected by means of a suitably-rated fuse or automatic circuit breaker.

Caution: Use correct lifting point

When lifting the antenna unit, always lift from the base plate. Do NOT use the antenna cover or damage to the cover could occur.

Caution: Do not damage connectors

Take care to avoid damage to the connectors underneath the antenna base plate when moving the unit. Do NOT use these connectors to lift the unit.

Caution: Remove transit packing

Before installing or operating the product, open the antenna unit cover and remove the foam transit packing inserts from the unit base.

Caution: Antenna coating

Do NOT paint or apply any other finish to the antenna unit. This could degrade performance beyond acceptable limits.

Important information

Handbook information



This handbook describes how to install, operate and maintain the Raymarine 33 Satellite Television (33STV) system.

While out at sea or docked, the Raymarine Satellite TV system automatically identifies, acquires and tracks compatible signals from

all digital video broadcast (DVB) satellites. This provides access to hundreds of TV channels.

Please carefully read and follow the installation, operating and maintenance procedures.

IMO and SOLAS

The equipment described within this document is intended for use on leisure marine boats and workboats not covered by International Maritime Organization (IMO) and Safety of Life at Sea (SOLAS) Carriage Regulations.

Geographic location

Satellites outside of North America transmit signals on a linear polarization, this means signals are transmitted horizontally and vertically. Satellites covering North America transmit circularly polarized signals that rotate. If the rotation is clockwise towards the direction of propagation, it is called right-hand-circular (RHC). If the rotation is counterclockwise, it is called left-hand-circular (LHC).

You cannot receive signals that have linear polarization on a system that is set up for circular polarization, or vice-versa.

The STV System will receive signals from selected satellites in the following areas.

Circular polarization:

- North America

Linear polarization:

- Europe
- Australia
- New Zealand
- China
- Middle East

Up to date coverage maps and satellite information are found by navigating to the home page of the satellite service providers.

If you change your area of operation, you may need to change some settings on your STV system:

- If your geographic location changes, you may need to:
 - Adjust the antenna low noise block (LNB) as appropriate for the area in which you are operating.
 - Change your control board, ACU software and satellite receivers (IRDs).

For full details of changing your geographic area of operation, contact Raymarine Product Support.

Television reception

For full functionality of your STV System, you must subscribe to the relevant service(s) from the appropriate service provider(s). Full details of service providers are given.

EMC conformance

Raymarine equipment and accessories conform to the appropriate Electromagnetic Compatibility (EMC) regulations for use in the recreational marine environment.

Correct installation is required to ensure that EMC performance is not compromised.

Declaration of conformity

This product conforms with EU Directive 2004/108/EC and is labelled with the CE conformity mark.

Product disposal

Dispose of this product in accordance with the WEEE Directive.



■ The Waste Electrical and Electronic Equipment (WEEE) Directive requires the recycling of waste electrical and electronic equipment. Whilst the WEEE Directive does not apply to some Raymarine products, we support its policy and ask you to be aware of how to dispose of this product.

Warranty registration

To register your Raymarine product ownership, please take a few minutes to fill out the warranty registration card found in the box, or visit www.raymarine.com and register on-line.

It is important that you register your product to receive full warranty benefits. Your unit package includes a bar code label indicating the serial number of the unit. You should stick this label to the warranty registration card.

Technical accuracy

To the best of our knowledge, the information in this document was correct at the time it was produced. However, Raymarine cannot accept liability for any inaccuracies or omissions it may contain. In addition, our policy of continuous product improvement may change specifications without notice. As a result, Raymarine cannot accept liability for any differences between the product and this document.

Chapter 2: Installation

Chapter contents

- [2.1 Preparation on page 12](#)
- [2.2 Procedures on page 18](#)

2.1 Preparation

EMC installation guidelines

Raymarine equipment and accessories conform to the appropriate Electromagnetic Compatibility (EMC) regulations, to minimize electromagnetic interference between equipment and minimize the effect such interference could have on the performance of your system

Correct installation is required to ensure that EMC performance is not compromised.

For **optimum** EMC performance we recommend that wherever possible:

- Raymarine equipment and cables connected to it are:
 - At least 1 m (3 ft) from any equipment transmitting or cables carrying radio signals e.g. VHF radios, cables and antennas. In the case of SSB radios, the distance should be increased to 7 ft (2 m).
 - More than 2 m (7 ft) from the path of a radar beam. A radar beam can normally be assumed to spread 20 degrees above and below the radiating element.
- The product is supplied from a separate battery from that used for engine start. This is important to prevent erratic behavior and data loss which can occur if the engine start does not have a separate battery.
- Raymarine specified cables are used.
- Cables are not cut or extended, unless doing so is detailed in the installation manual.

Note: Where constraints on the installation prevent any of the above recommendations, always ensure the maximum possible separation between different items of electrical equipment, to provide the best conditions for EMC performance throughout the installation

Suppression ferrites

Raymarine cables may be fitted with suppression ferrites. These are important for correct EMC performance. If a ferrite has to be removed for any purpose (e.g. installation or maintenance), it must be replaced in the original position before the product is used.

Use only ferrites of the correct type, supplied by Raymarine authorized dealers.

Connections to other equipment

Requirement for ferrites on non-Raymarine cables

If your Raymarine equipment is to be connected to other equipment using a cable not supplied by Raymarine, a suppression ferrite **MUST** always be attached to the cable near the Raymarine unit.

Parts supplied

The following parts are provided for a 33STV system:

- Antenna Unit
- Antenna Control Unit (ACU)
- Installation Kit comprising:
 - Bolts
 - Flat washers
 - Spring washers
 - Self tapping screws
- Cables as follows:

- R08321 - 10 m Power cable - used for connecting the ACU to the DC power supply.
- R08257 - 3 m RF cable - used for connecting the ACU and Integrated Receiver Decoder (IRD)
- R08135 - 15 m RF cable - used for connecting the Antenna and ACU.
- R42173 - 1.5 m USB AB Type PC cable- used for connecting the ACU to a PC for system setup and diagnostic.
- R42174 - 1.8 m USB AM to AM Type cable- used for connecting the ACU to IRD (Only compatible with DIRECTV receiver).
- CDROM - contains:
 - Software for running the STV Graphical User Interface (GUI) on a personal computer (PC).
 - Product user manual, as PDF.

Tools required

Tools necessary for installation.

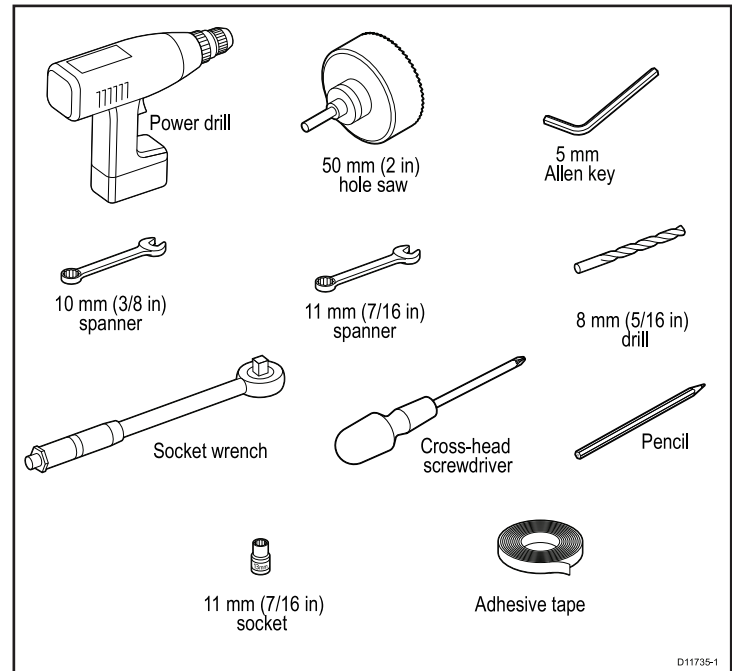

D11735-1

Planning

Antenna unit

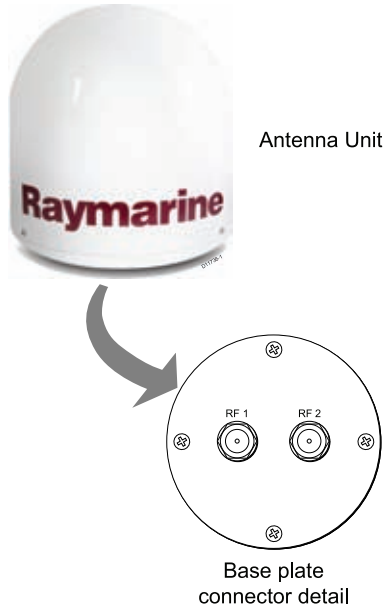

The Antenna unit comprises the antenna dish, positioning mechanism, low noise block (LNB), power supply and control elements in a molded radome.

Connectors on the underside of the base plate connect the power, signal and control cabling from the below decks units.

For connection details, refer to the installation procedures.

Antenna Control Unit (ACU)

The Antenna Control Unit (ACU) provides all control and power-switching functions for the antenna. Three soft keys enable satellite programming and antenna diagnostics to be carried out.

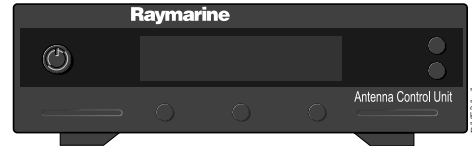

Two buttons at the right-hand side of the front panel are used with some setup procedures to provide **BACK** and **ENTER** functions.

The ACU rear connectors are:

- **DC 9 to 30V** for power input.
- **ANT RF1** - connects power and signal to the antenna.
- **NMEA** - connects to GPS (optional).
- **PC INTERFACE** - connects to PC for remote operation from a computer (optional).
- **RECEIVER** - connects to the satellite receiver (not supplied).

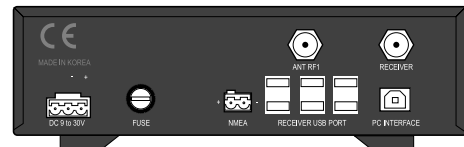

For connection details, refer to the installation procedures.

Antenna position

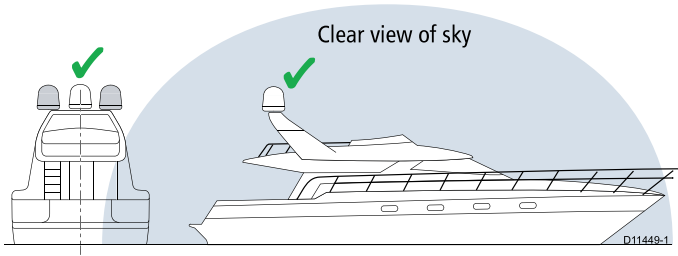

The antenna, must be installed where:

- There is an all round clear view of the horizon.
- It is not too high above the water - the maximum recommended height is one not exceeding half the length of the boat.
- It is as near as possible to the centerline of the boat.
- On a rigid mounting platform that is not subject to excessive vibration.
- Away from the edge of the boat. This will minimize excessive motion, which can adversely affect reception.
- Clear of any radar beam. This could adversely affect antenna operation.

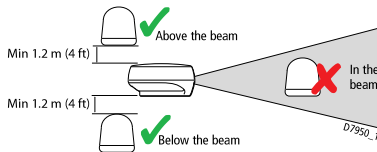

- Clear of any object which could block the satellite signal. Ensure there is a +15° to +90° look angle at the intended installation position.

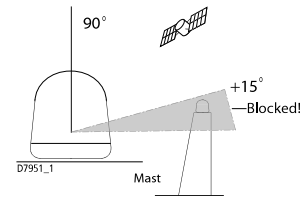

ACU installation

The ACU must be fitted below decks in a position that is:

- Dry.
- Well ventilated.
- Easily accessible.
- Near to the main TV viewing area.

ACU dimensions

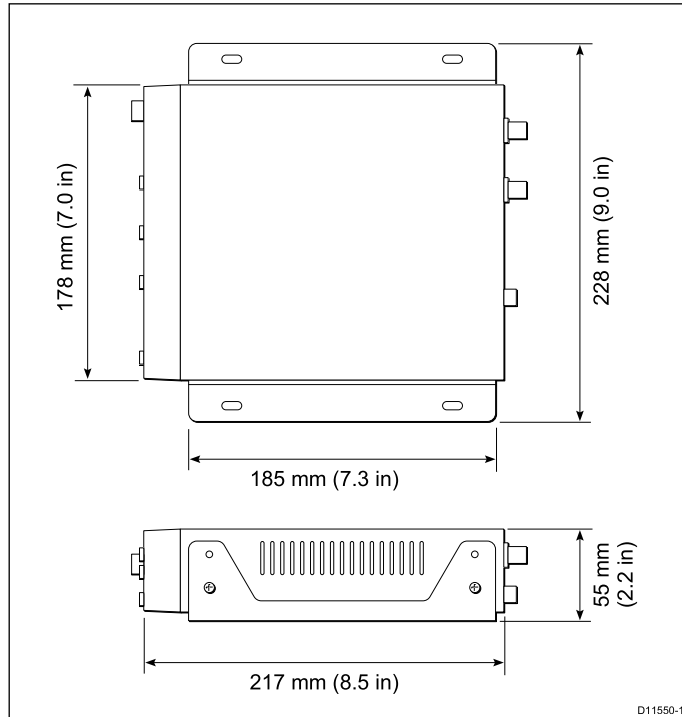

Routing cables

Cables must be routed correctly, to maximize performance and prolong cable life.

- Do NOT bend cables excessively. Wherever possible, ensure a minimum bend radius of 100 mm.

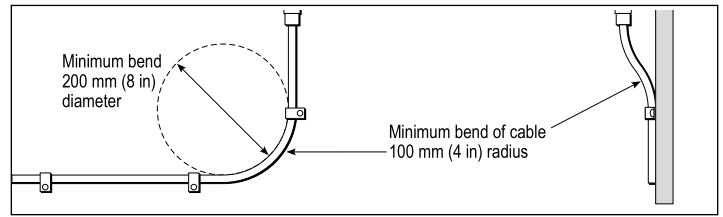

- Protect all cables from physical damage and exposure to heat. Use trunking or conduit where possible. Do NOT run cables through bilges or doorways, or close to moving or hot objects.
- Secure cables in place using tie-wraps or lacing twine. Coil any extra cable and tie it out of the way.
- Where a cable passes through an exposed bulkhead or deckhead, use a suitable watertight feed-through.
- Do NOT run cables near to engines or fluorescent lights.

Always route data cables as far away as possible from:

- other equipment and cables,
- high current carrying ac and dc power lines,
- antennae.

Power Requirements

A Raymarine 33STV system needs either a 12 V dc or 24 V dc power supply.

If the IRD(s) and television(s) require a 220/240 V ac power supply, a suitable dc-to-ac converter must be fitted, to provide the necessary power from the boat's dc power supply.

Grounding

These grounding requirements are applicable for Raymarine equipment supplied with a separate drain wire or screen.

- The product power cable drain conductor (screen) must be connected to a common ground point.
- It is recommended that the common ground point is a bonded ground, i.e. with the ground point connected to battery negative, and situated as close as possible to the battery negative terminal. If a bonded ground system is not possible, a non-bonded RF ground may be used.

Bonded ground system (preferred)

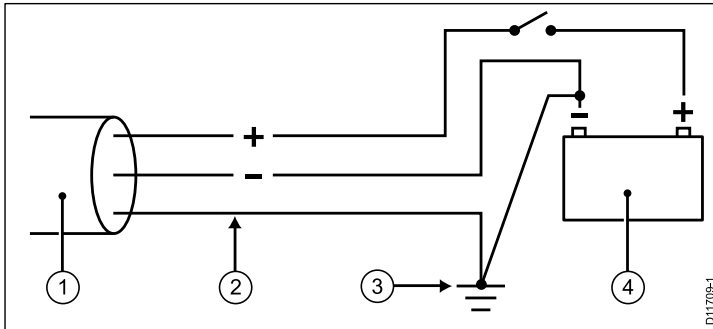

RF ground system (alternative)

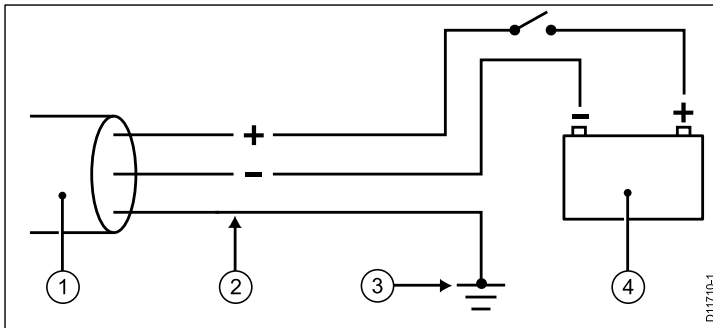

1. Power cable to product
2. Drain (screen)
3. Bonded (preferred) or non-bonded RF ground.
4. Battery

Implementation

If several items require grounding, they may first be connected to a single local point (e.g. within a switch panel), with this point connected via a single, appropriately-rated conductor, to the boat's common ground. The preferred minimum requirement for the path to ground (bonded or non-bonded) is via a flat tinned copper braid, with a 30 A rating (1/4 inch) or greater. If this is not possible, an equivalent stranded wire conductor maybe used, rated as follows:

- for runs of <1 m (3 ft), use 6 mm² (#10 AWG) or greater.
- for runs of >1 m (3 ft), use 8 mm² (#8 AWG) or greater.

In any grounding system, always keep the length of connecting braid or wires as short as possible.

Important: Do NOT connect this product to a positively-grounded power system.

References

- ISO10133/13297
- BMEA code of practice
- NMEA 0400

Extending cable runs

Note: System performance will be reduced if supplied cables are extended.

If the RF cable supplied as standard is not long enough, a 98 ft (30 m) cable, is available from your Raymarine dealer, (part number E96008). Connect the longer cable to the supplied 15 m (49 ft) RF cable to obtain a total cable length of 147 ft (45 m).

Note: Total cable lengths should not exceed 45 m (147 ft). System performance can not be guaranteed if cables are extended.

2.2 Procedures

Antenna installation

The procedures for installing the antenna assembly comprise:

- Preparation - remove transit packing.
- Procedure - prepare mount and fit antenna.

Antenna preparation

1. Remove and retain the screws securing the antenna dome.
2. Remove the antenna dome and retain in a safe place.

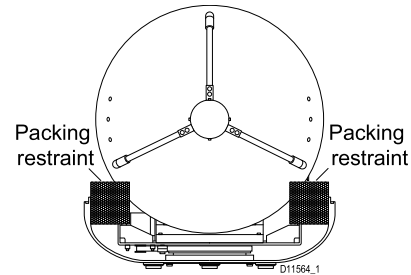

3. Locate and remove the packing restraints from the antenna assembly.
4. Replace the antenna dome and secure with the screws retained at step 1.

Antenna installation procedure

Prepare the mounting surface then fit the antenna.

1. Using adhesive tape, attach the template to the mounting surface, ensuring that it is parallel to your boat's center line as marked on the template.
2. Using a suitable hole saw, remove the shaded center portion.

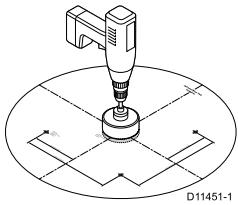

3. Drill four 8 mm holes in the positions indicated.

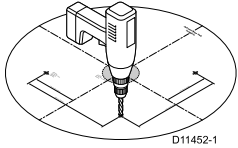

4. Countersink the mounting holes, then smooth the edges of the center hole with a suitable file, to avoid damage to the mounting surface.
5. Secure the antenna to the base using the supplied bolts, spring washers, flat washers and nut.

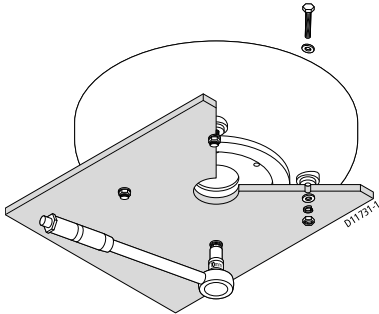

6. Tighten the bolts and ensure that the foam sealing ring is compressed to prevent water ingress. Be sure not to overtighten the fixings or cross-thread any of the bolts.

Installing the ACU

Use the two fixing brackets supplied to install the ACU. These brackets can be fitted to the sides of the unit to provide a top or bottom fix.

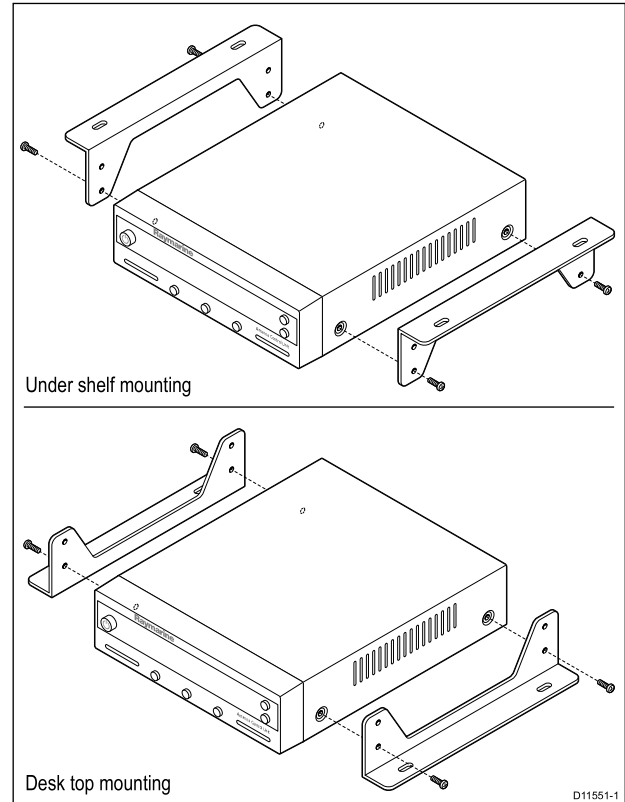

1. Select the installation site, ensuring that the proposed site meets the criteria described under Planning the ACU installation.
2. Use the screws from the ACU to fix the mounting brackets to the ACU.
3. Place the ACU in the position where it is going to be installed.
4. Mark the 2 fixing hole positions for each mounting bracket, on the mounting surface.
5. Using a suitable drill bit, drill the 4 holes in the marked positions.
6. Where necessary (for example, on gel-coated surfaces), countersink the mounting holes to avoid damage to the mounting surface.
7. Using suitable screws, secure the ACU into position.

System options

Your Raymarine Satellite TV system can be connected to one or multiple IRDs, to offer the maximum choice of channels to different cabins. This section describes the different combinations available and the method of connecting each variant.

Ensure the power supply for the ACU is protected by either a 5 A quick-blow fuse or an equivalent automatic circuit breaker, connected in-line on the positive (white with red tag) wire of the power cable.

Note that for all variants, the **RF1** connector on the ACU must be connected to the **RF1** connector on the antenna base plate.

Connecting a basic system

For DIRECTV subscribers: When the system starts up, the IRD can take 20~30 minutes to fully load the program guide for all three DIRECTV satellites. To enable you to watch TV whilst the list is being loaded only select channels carried on the 101 satellite until the program guide is fully loaded.

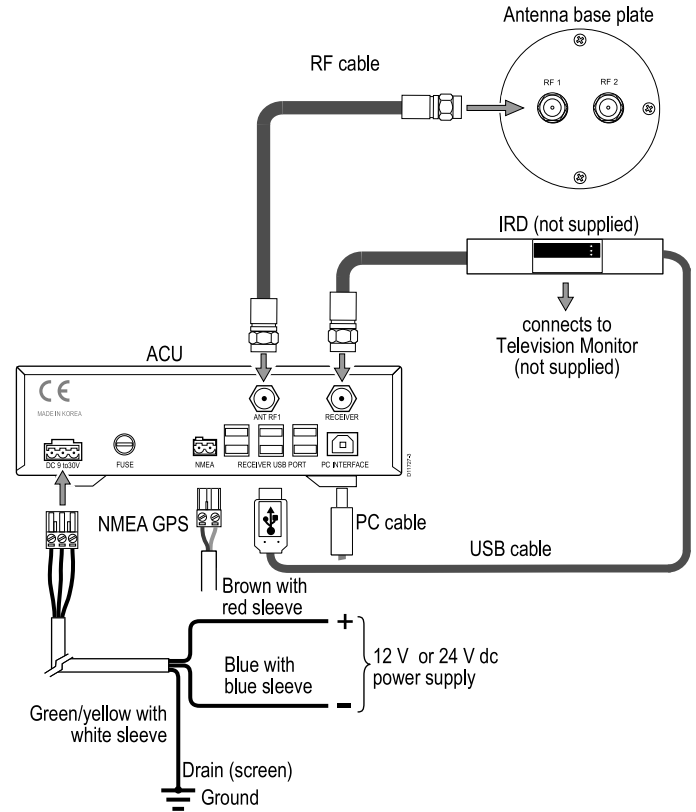

Note: USB Connection to IRD is for use with DIRECTV only.

1. Connect an RF cable from the **ANT RF1** connector on the ACU to the **RF1** connector on the antenna base plate.

2. Connect an RF cable from the **RECEIVER** connector on the ACU to either the **LNB**, **ANT**, or **Satellite In** connector on the rear of the IRD.
3. **DIRECTV ONLY**— Connect a USB cable from the **IRD1** USB port on the ACU to the **USB** port on the IRD.
4. Connect the power cable with a 12 V or a 24 V dc supply to the **DC 9 to 30 V** connector on the rear of the ACU.
5. Refer to the relevant Manufacturer's handbook for details on configuring your IRD.

System with 2 IRDs

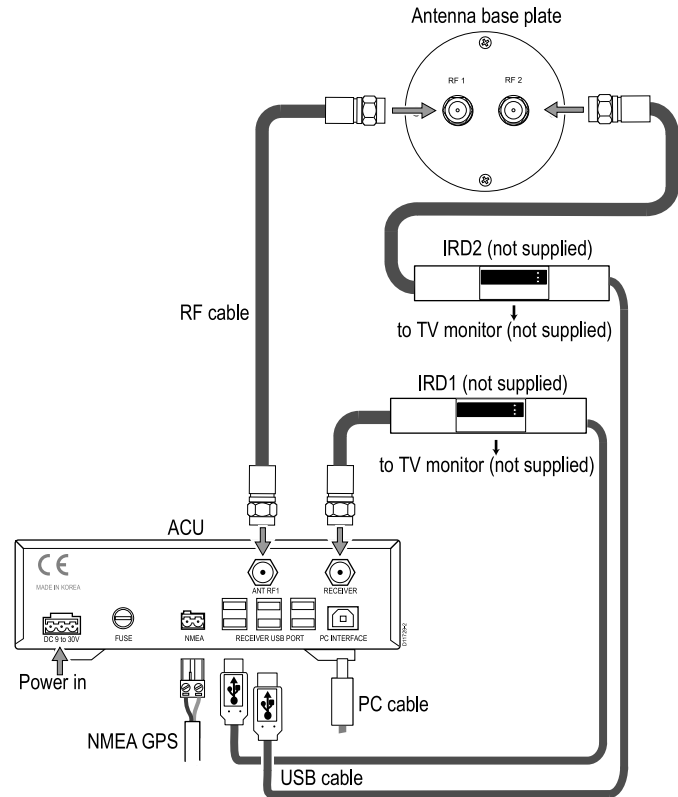

Note: USB Connection to IRD is for use with DIRECTV only.

You can connect two IRDs to your antenna as shown in the diagram. In this system, both IRDs can be set as master, which can change the target satellite freely by selecting a channel.

The RF cables from the antenna base plate connect to either the **LNB**, **ANT**, or **Satellite In** connector on the rear of the IRD.

Connect USB cables from an **IRD USB** port on the ACU to the **USB** port on the IRDs.

Refer to the relevant manufacturer's handbook for details on configuring IRDs.

System with more than 2 IRDs

To connect multiple IRDs to your antenna, you should purchase a suitable active multiswitch. The multiswitch should be installed between the antenna unit and the IRDs (as shown). Ensure the RF cable from the ACUs **RECEIVER** and the **LHCP/18V** on the multiswitch are connected as shown in the diagram.

North America

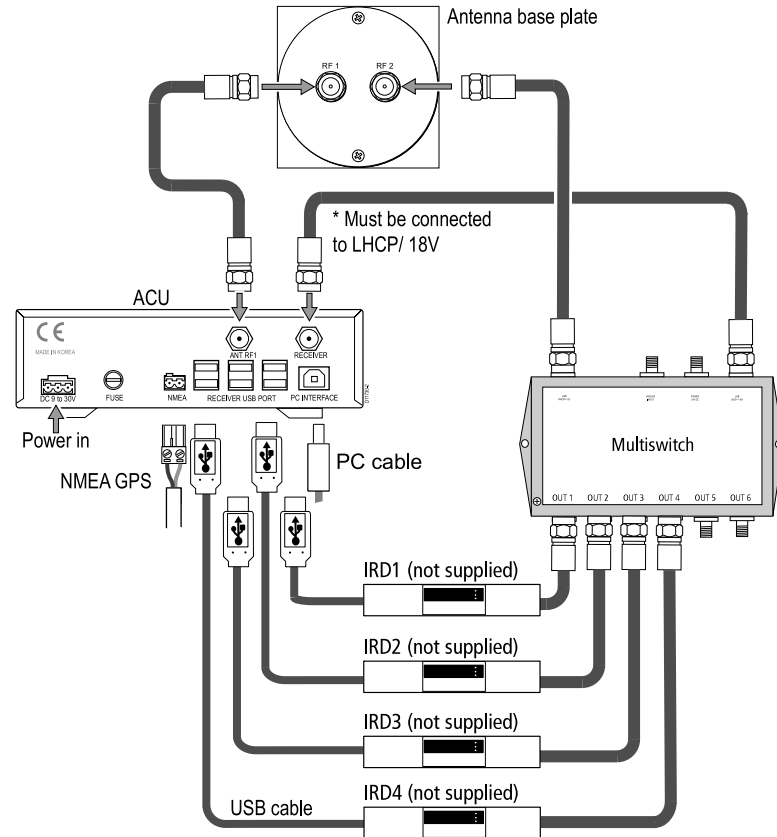

Note: USB Connection to IRD is for use with DIRECTV only.

The RF cables from the multiswitch connect to either the **LNB, ANT,** or **Satellite In** connectors on the rear of the IRDs.

Connect USB cables to the **IRD USB** ports on the ACU to the **USB** port on the IRDs.

Refer to the relevant Manufacturer's handbook for details on configuring your IRDs.

Up to six IRDs can be connected to the ACU and every IRD can be a master, which can change the target satellite freely by selecting a channel.

STV with NMEA 0183 GPS

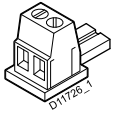

NMEA
connector

You can improve the tracking accuracy of your Raymarine STV system by using the supplied 2 pin connector (as above), to connect your STV system directly to your boat's NMEA 0183 GPS system. You will need to provide:

- a length of cable suitable for connecting to your GPS antenna.
- a suitable connector block.

Connecting STV to NMEA 0183 GPS

With the system powered OFF, connect an NMEA feed to the ACU for GPS positioning information, refer to the following illustration for reference:

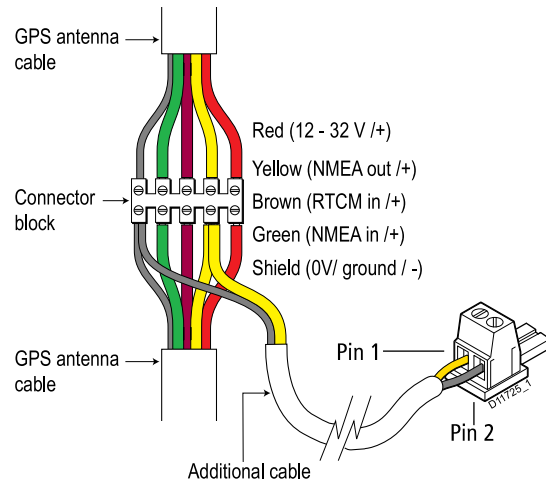

1. At a suitable point, cut your GPS antenna cable.
2. Strip each wire in the GPS and additional cable ready for the connector block.
3. Connect stripped GPS wires to the connector block, matching the wires on either side.
4. Put the NMEA OUT wire (yellow in the illustration) and ground wire into the connector block with the corresponding GPS antenna wires, as in the illustration.
5. Secure all connections in the connector block.
6. Connect and secure the free end of the additional cable in the 2 pin plug, so that:
 - i. NMEA OUT (+) connects to pin 1.
 - ii. Ground (-) connects to pin 2.
7. Connect the 2 pin plug to **NMEA** on the rear of the ACU.
8. Switch on the STV system.

Chapter 3: System operation & setup

Chapter contents

- [3.1 Introduction on page 26](#)
- [3.2 Getting started on page 26](#)
- [3.3 Setup using the ACU on page 28](#)
- [3.4 Applying factory default values on page 37](#)
- [3.5 System information on page 37](#)
- [3.6 Checking system power on page 38](#)
- [3.7 Skew angle on page 38](#)
- [3.8 Graphical user interface on page 39](#)

3.1 Introduction

This section of the handbook describes how to set up your Raymarine Satellite TV system after installation using the ACU or the Graphical User Interface (GUI), and includes the following functions:

- System start up
- Change the default satellite
- Monitor the antenna status
- Setting sleep mode
- Enter set up mode
- Setting your operating region
- Setting the default satellites
- Setting up Remote Control
- Setting the GPS
- Editing satellite information
- Setting antenna parameters
- Setting the local frequency
- Setting the DiSEqC method
- Display versions
- Setting antenna go position
- Setting antenna move step

Many of the above functions will only be required at initial installation of your system.

Important: Raymarine does not recommend changing the satellite information unless advised to do so by the satellite provider.

Note: The satellite names shown on the ACU screen are dependent on geographic location and therefore may be different to the names in this manual.

Note: Vertical and horizontal polarization applies to regions with linear polarization only.

3.2 Getting started

Switching on

Ensure your IRDs and television monitors are switched on.

Press the power switch on the ACU to switch on the system. Check on the ACU that the start-up screens are displayed in the correct sequence.

Startup sequence

Start of communication between antenna and the ACU.



Antenna initialized.



Antenna is searching for Satellite A.



Operating mode - antenna tracking satellite



System set with two default satellites



System set with three default satellites

D11737-1

Changing the target satellite

Your satellite system can be set up to track either two or three default satellites, depending on your geographical location. The

name of the satellite the system is currently tracking is shown in the top line of the ACU display.

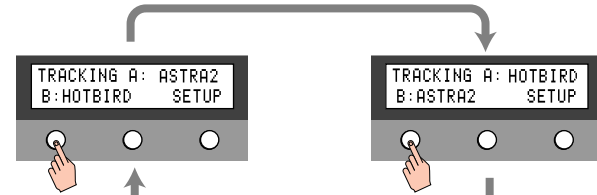

System with 2 default satellites

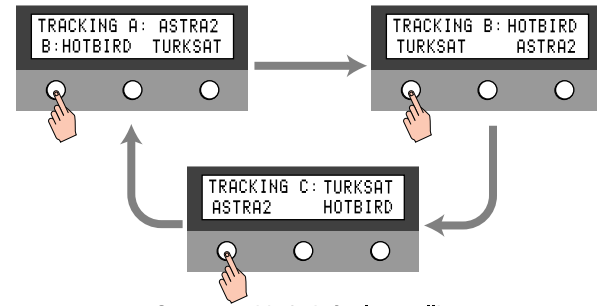

System with 3 default satellites

To change the default satellite, press the left hand soft key. The default satellite changes and is automatically tracked by the antenna.

Monitoring antenna operation

With the system switched on and running, the ACU display shows the current status of the antenna. This can be either:

- **TRACKING** - the antenna is tracking the satellite
- **SEARCH** - the antenna is looking for the satellite
- **UNWRAPPING** - the antenna is unwrapping cable

You can check the details of the satellite position by pressing the center soft key:

- Once to see the elevation
- Twice to see latitude, longitude and signal strength
- Three times to return to the normal operating display

Setting sleep mode

If the antenna loses the tracking satellite whilst in sleep mode, sleep mode is cancelled. To register a key on your remote control to access sleep mode see 'Setting the remote control'.

1. Press **Back** to access sleep mode.
2. Press **Back** again to exit sleep mode.



3.3 Setup using the ACU

Setup principles

Using the ACU

The ACU setup mode gives access to a series of setup pages, to enable you to adjust the system parameters.

When setting up the system from the ACU, three context-dependent soft keys below the display are used to select and adjust the required parameters.

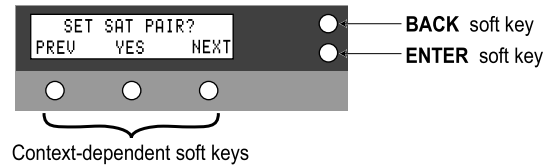

Single function soft keys are used only during setup routines:

- The **BACK** soft key enables you go to the previous screen.
- The **ENTER** soft key is used to confirm settings.

You can:

- Define a pair or trio of satellites you want to use.
- Set the system to work with GPS.
- Edit a range of satellite information.
- Set various antenna parameters.
- Set the LNB local frequency.
- Set the DiSEqC method.
- Reset the system to factory default values.

You can also use setup mode to manually control the direction that the antenna points.

Setup routines

In setup mode, use the **PREV** or **NEXT** soft key to select the required setup screen.

For some setup functions, you also use the **PREV** and **NEXT** soft key to select a particular value. For example, when setting default satellites, you use **PREV** or **NEXT** cycle through the names of available satellites.

Editing screens

Some setup screens enable you to edit individual characters and are typically presented in this manner:

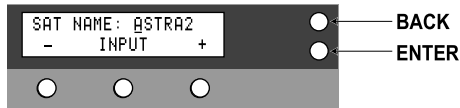

On the screen, the editable character is indicated by an underscore cursor (under A in this illustration).

To edit the characters:

1. With the cursor under the first character, use the - and/or + keys to move through the available characters until the required character is displayed above the cursor.
2. Press the **INPUT** soft key to accept the edited character. The cursor then moves to the next character.
3. Repeat steps 1 and 2 until you have edited all necessary characters. If you want to change any character, use the **BACK** soft key to move the cursor to the relevant character.
4. When you have completed the edit for a screen, press the **ENTER** soft key to accept the values and move to the next setup screen.

Entering setup mode

Enter setup mode as follows:

1. Press the **ENTER** soft key to display the setup entry page.

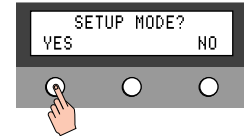

2. Press the **YES** soft key to display the **SET SAT PAIR?** screen. This is the first screen in setup mode.

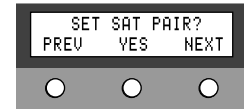

Setting the operating region

Use this procedure to set the region you are operating in.

1. Carry out the **ENTER** setup mode procedure to display the **SET SAT PAIR?** screen.
2. Press the **PREV** soft key twice to display the **LOAD REGION INFO?** screen.
3. Press the **YES** soft key to display the **CONTINENT** select screen.
4. Use the **PREV** or **NEXT** soft key to cycle through the continent names in the top line of the display, until the required continent name is displayed.
5. Press the **SELECT** soft key to confirm the continent and display the **REGION** screen.
6. Use the **PREV** or **NEXT** soft key to cycle through the region names in the top line of the display, until the required region name is displayed.
7. Press the **SELECT** soft key to confirm the region and display the **LOAD?** screen.
8. Press either:

- **YES** to load the new settings. When the new settings have been loaded, the system re-initializes automatically.
 - **NO** to return to the **SETUP MODE?** screen without making any changes.
9. If the **SETUP MODE?** screen is displayed, press:
- **YES** if you want to remain in setup mode, or
 - **NO** to re-initialize the system and return to operational mode.

Setting the default satellites

Use this procedure to set either two or three default satellites.

1. Carry out the Enter setup mode procedure to display the **SET SAT PAIR?** screen.
2. Press the **YES** soft key to display the **SET TRIPLE SAT** screen.
3. If you are in an area where three satellites are available press **YES**. Otherwise, press **NO**.
4. Use the **PREV** or **NEXT** soft key to cycle through the satellite names, in the top line of the display.
5. When the required satellite name is displayed, press the **SELECT** soft key to select this satellite as satellite A.
6. Repeat steps 4 and 5 to select satellite B.
7. If you are setting up triple satellites, repeat steps 4 and 5 to select satellite C.
8. When the **SAVE?** screen is displayed, press the **YES** soft key.
9. When the **SETUP?** screen is displayed, press either soft key:
 - **YES** if you want to remain in setup mode, or
 - **NO** to re-initialize the system and return to operational mode.

Setting the remote control

Use this procedure to set up your remote control with the ACU.

1. Carry out the enter setup mode procedure to display the **SET SAT PAIR?** screen.
2. Press the **NEXT** soft key 8 times to display the **SET REMOCON?** screen.
3. Press **YES** to display the **CHANGE SAT** set screen.
4. Press the **SELECT** soft key to display the **PRESS A REMOTE KEY** screen.
5. Point your remote control towards the ACU, then press the remote control button that you want to allocate to the selected function.
6. Press the same remote control button again to confirm the selection.
7. If you want to set up another remote function:
 - i. At the ACU, press the **BACK** soft key.
 - ii. Press the **NEXT** soft key to select the next function to set up.
 - iii. Repeat steps 4 to 7 above.
8. When all required functions have been set for remote control, press the **EXIT** soft key to return to the main setup mode.

Setting MutiSat interface module (MIM)

Note:

MIM functions are only available when connected to a DIRECTV receiver.

Up to six IRDs can be connected to the ACU. Every IRD can be a master, which can change the target satellite freely by selecting a channel.

Follow the steps below to enable/disable this function:

1. Press **YES** to enter setup mode.
2. Press **NEXT** eleven times to enter **MIM** mode
3. Press **YES** to set MIM

4. Press **ON/OFF** to set MIM port On and Off,
 - **PREV**- Moves previous IRD port.
 - **NEXT**- Moves next IRD port.
 - Press **ENTER** to move to next screen.
5. Press **YES** to save selections. Press **NO** to cancel and return to main setup mode.

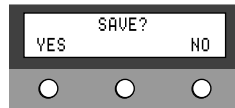
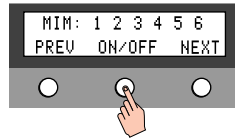
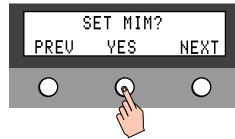
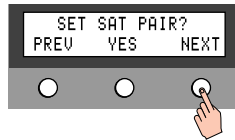

D11742-1

Setting the GPS

1. Enter setup mode, so that the **SET SAT PAIR?** screen is displayed.
2. Press the **NEXT** soft key once to display the **SET GPS?** screen.
3. Press **YES** to enter GPS setup mode and display the **LONGITUDE** screen.
4. Set the current longitude as follows:
 - i. Use the **+** and **-** soft keys to enter the required value for the character above the cursor (underscore).
 - ii. Press the **INPUT** soft key to accept each correct character and move the cursor to the next character.
 - iii. Repeat sub-steps a, b and c until the correct longitude numeric value has been entered and the cursor is under the longitude direction indicator, **E** (east) or **W** (west).
 - iv. Use the **E** or **W** soft key to set the appropriate direction.
5. Press the **INPUT** soft key to proceed to the **LATITUDE** screen.
6. Set the current latitude as follows:
 - i. Use the **+** and **-** soft keys to enter the required value for the character above the cursor.
 - ii. Press the **INPUT** soft key to accept each correct character and move the cursor to the next character.
 - iii. Repeat steps a, b and c until all correct latitude values have been entered and the cursor is under the latitude direction indicator, **N** (north) or **S** (south).
 - iv. Use the **N** or **S** soft key to set the appropriate direction
7. Press the **INPUT** soft key to proceed to the **SAVE?** screen.
8. Press either:
 - **YES** to save your settings, or
 - **NO** to cancel the operation and return to the **SETUP MODE?** screen.

Note: If your system is connected to a GPS antenna, the position will be updated in real time.

Satellite information

Important: We recommend that you do NOT attempt to edit satellite information. However, if you have to do so, contact the Raymarine Customer Support Department for advice before making any changes.

The editable parameters are typically, in sequence:

- **LONGITUDE** in degrees and minutes, plus E/W selector.
- **VER LOW/RHCP**. Vertical low band tracking frequency (in MHz) and symbol rate (in kHz).
- **VER LOW NID**. Vertical low band network identity (NID).
- **HOR LOW/LHCP**. Horizontal low band tracking frequency (in MHz) and symbol rate (in kHz).
- **HOR LOW NID**. Horizontal low band network identity (NID).
- **VER HIGH**. Vertical high band tracking frequency (in MHz) and symbol rate (in kHz).
- **VER HIGH NID**. Vertical high band network identity (NID).
- **HOR HIGH**. Horizontal high band tracking frequency (in MHz) and symbol rate (in kHz).
- **HOR HIGH NID**. Horizontal high band network identity (NID).
- The method of verifying satellite tracking. The options are:
 - **SIGNAL** - use only the signal level for tracking.
 - **DVB LOCK** - use only DVB Lock signal for tracking.
 - **DVB DECODE** - verify signal using DVB decoding method for tracking.
 - **DSS DECODE** - decode only DSS Lock signal for tracking.
- The method of supplying power to the LNB. The options are:
 - **AUTO** - change voltage to LNB by the IRD voltage. This is the RECOMMENDED SETTING.

- **ONLY 13 V** - always supply 13 V to LNB.
- **ONLY 18 V** - always supply 18 V to LNB.
- The required method of Digital Satellite Equipment Control (DiSEqC). The options are:
 - **AUTO** - change signal to LNB by the IRD DiSEqC. This is the RECOMMENDED SETTING.
 - **ONLY 0 KHZ** - always supply 0 kHz to LNB.
 - **ONLY 22KHZ** - always supply 22 kHz to LNB.

Editing satellite information

To edit satellite information, start with normal operating information displayed on the ACU, then at the ACU:

1. Carry out the Enter setup mode procedure to display the **SET SAT PAIR?** screen.
2. Press the **NEXT** soft key twice to display the **EDIT SAT INFO?** screen.
3. Press **YES** to enter the edit mode.

A satellite name edit screen is displayed.
4. Use the **PREV** or **NEXT** soft key to scroll to the name of the satellite you want to change.
5. To edit the displayed satellite name, press the **SELECT** soft key.

An edit screen is displayed.
6. Change the displayed name as follows:
 - i. Use the **+** and **-** soft keys to change the value of the character above the cursor (underscore).
 - ii. Press the **INPUT** soft key to accept each correct character and move the cursor to the next character.
 - iii. Repeat sub-steps a, b and c until the correct name has been entered.
7. Press the **ENTER** soft key to confirm the edited data and display the edit screen for the next parameter.

8. Using a procedure similar to that in steps 2 to 7 above, edit the other satellite parameters as required. The editable parameters are typically, in sequence:

- **LONGITUDE**
- **VER LOW/RHCP**
- **VER LOW NID.**
- **HOR LOW/LHCP**
- **HOR LOW NID**
- **VER HIGH**
- **VER HIGH NID**
- **HOR HIGH**
- **HOR HIGH NID**

Press the **ENTER** button to accept the **HOR HIGH NID** value, and display the **VERIFY** screen.

9. If necessary, use the **PREV** or **NEXT** soft key to select the required method for verifying satellite tracking.
10. Press the **ENTER** button to accept the **VERIFY** method and display the **VOLTAGE** screen.
11. If necessary, use the **PREV** or **NEXT** soft key to select the required method of supplying power to the LNB.
12. Press the **ENTER** button to accept the **VOLTAGE** method and display the **DISEQC** screen.
13. If necessary, use the **PREV** or **NEXT** soft key to select the required method of Digital Satellite Equipment Control (DiSEqC). The options are:
- i. **AUTO**
 - ii. **0KHz**
 - iii. **22KHz**
14. Press the **ENTER** soft key to accept the **DISEQC** method and display the **SAVE?** screen.
15. Press, either:

- The **YES** soft key to save the changes you have made, or
- The **NO** soft key to discard any changes.

The **SETUP MODE?** entry screen is then displayed.

16. Press either:

- the **YES** soft key, if you want to use another setup function, or
- the **NO** soft key, to re-initialize the system using the new settings.

Antenna parameters

Important: We recommend that you do NOT attempt to change the antenna parameters. However, if you have to do so, contact the Raymarine Customer Support Department for advice before making any changes.

The antenna parameters you can change are typically, in sequence:

- **SCAN OFFSET.** The angle between the marked point on the sub-reflector and the datum.
- **TRACK SCALE.** To determine the speed at which the antenna tracks a satellite. A high Track Scale value gives a high tracking speed.
- **DETECT LEVEL.** The basic signal detection level.
- **WRS LEVEL.** The basic WRS detection level.
- **TRACK OFFSET.**
- **POWER LEVEL.**
- **DISEQC LEVEL.** The value that identifies a 22 kHz tone.
- **OFFSET RH - LH.** The difference value between RHCP/LHCP and SCAN OFFSET.
- **EL OFFSET.**

- **USE WRS.** Applies WRS while antenna is searching for satellite.
- **OFFSET DIFF.** Applies Offset Difference.

Editing antenna parameters

1. Carry out the Enter setup mode procedure to display the **SET SAT PAIR?** screen.
2. Press the **NEXT** soft key three times to display the **SET ANT PARAMETER?** screen.
3. Press **YES** to enter parameter edit. The **PARAM: SCAN OFFSET:** screen is displayed.
4. Use the **PREV** and **NEXT** soft keys as necessary, to display the parameter you want to change.
5. To change the displayed parameter, press the **YES** soft key.

An edit screen is displayed.

6. Change the displayed parameter as follows:
 - i. Use the **+** and **-** soft keys to change the value of the character above the cursor (underscore).
 - ii. Press the **INPUT** soft key to accept each correct character and move the cursor to the next character.
 - iii. Repeat sub-steps a, b and c until the correct name has been entered.
7. Press the **ENTER** soft key, to display the **ANOTHER PARAMETER?** screen.
8. To:
 - Exit the setup procedure, press the **NO** soft key to display the **SAVE?** screen.
 - Set up another antenna parameter, press the **YES** soft key to return to the parameter change routine, then repeat steps 4 to 8 as necessary.
9. When the **SAVE?** screen is displayed, press, either:
 - The **YES** soft key to save the changes you have made, or

- The **NO** soft key to discard any changes.

The **SETUP MODE?** entry screen is then displayed.

10. Press either:

- the **YES** soft key, if you want to use another setup function, or
- the **NO** soft key, to re-initialize the system using the new settings.

Setting LNB local frequency

We recommend that you do NOT attempt to change the LNB local frequency.

However, if you have to do so, contact the Raymarine Customer Support Department for advice before making any changes.

1. Carry out the Enter setup mode procedure to display the **SET SAT PAIR?** screen.
2. Press the **NEXT** soft key four times to display the **SET LOCAL FREQ?** screen.
3. Press **YES** to display the **LNB TYPE:** screen.
4. Carry out the setting up procedure for single band or universal band, as necessary.
 - Single band frequencies are:
 - Asia, 11300 Mhz.
 - Japan, 10678 MHz
 - Korea, 10750 MHz
 - America. 11250 MHz
 - Universal frequencies are:
 - Low band, 9750 MHz
 - High band, 10600 MHz

Setting single band LNB frequency

With the **LNB TYPE:** screen displayed:

1. Use the **PREV** or **NEXT** soft key to scroll to **SINGLE**
2. Press **SELECT** to display the **LOCAL FREQ** edit screen
3. Set the required frequency as follows:
 - i. Use the **+** and **-** soft keys to change the value of the character above the cursor (underscore), as necessary.
 - ii. Press the **INPUT** soft key to accept each correct character and move the cursor to the next character.
 - iii. Repeat sub-steps a, b and c until the correct frequency has been entered.
4. Press the **ENTER** button to accept the frequency value and display the **SAVE?** screen.
5. Press, either:
 - The **YES** soft key to save the changes you have made, or
 - The **NO** soft key to discard any changes.The **SETUP MODE?** entry screen is then displayed.
6. Press either:
 - **YES** if you want to use another setup function, or
 - **NO** to re-initialize the system using the new settings.

Setting universal LNB frequency

With the **LNB TYPE:** screen displayed:

1. Use the **PREV** or **NEXT** soft key to scroll to **UNIVERSAL**
2. Press, either:
 - The **YES** soft key to save the changes you have made, or
 - The **NO** soft key to discard any changes.The **SETUP MODE?** entry screen is then displayed.
3. Press either:

- **YES** if you want to use another setup function, or
- **NO** to re-initialize the system using the new settings.

Setting the DiSEqC method

We recommend that you do NOT attempt to change the DiSEqC.

However, if you have to do so, contact the Raymarine Customer Support Department for advice before making any changes.

1. Carry out the Enter setup mode procedure to display the **SET SAT PAIR?** screen.
2. Press the **NEXT** soft key five times to display the **USE DISEQC?** screen.
3. Press **YES** to display the DiSEqC edit screen.
4. Use the **PREV** or **NEXT** soft keys to select the required DiSEqC method. The options are:
 - **USE TO CHANGE BAND** - DiSEqC used to change high and low bands.
 - **USE TO CHANGE SAT** - DiSEqC used to change the satellite being tracked.
 - **DO NOT USE DISEQC** - DiSEqC not used.
5. Press the **ENTER** soft key to accept the frequency value and display the **SAVE?** screen.
6. Press, either:
 - The **YES** soft key to save the changes you have made, or
 - The **NO** soft key to discard any changes.The **SETUP MODE?** entry screen is then displayed.
7. Press either:
 - **YES** if you want to use another setup function, or
 - **NO** to re-initialize the system using the new settings.

Manually directing the antenna

You can use the ACU to manually control the antenna. The options are:

- Setting the antenna go position - you set horizontal and vertical angles to which you want the antenna to point.
- Antenna move step - enables you to manually step the antenna, to the required horizontal and vertical directions.

Setting antenna go position

1. Carry out the Enter setup mode procedure to display the **SET SAT PAIR?** screen.
2. Press the **PREV** soft key five times to display the **ANT GO POSITION?** screen.
3. Press **YES** to display the **GO TO AZ** edit screen.
4. Define the horizontal position to which you want the antenna to move, as follows:
 - i. Use the **+** and **-** soft keys to change the value of the character above the cursor (underscore).
 - ii. Press the **INPUT** soft key to accept each correct character and move the cursor to the next character.
 - iii. Repeat sub-steps a, b and c until the required value has been entered.
5. Press the **ENTER** soft key to confirm the horizontal position and display the **GO TO EL** edit screen.
6. Using a procedure similar to that in steps 4 and 5, define the vertical position to which you want the antenna to move.
7. Press the **ENTER** soft key to confirm the vertical position and display the **GOTO POSITION?** screen.
8. Press:
 - **YES** to drive the antenna to the position you have set. When you no longer need the antenna to point in this direction, press the **EXIT** soft key to return to the **SETUP MODE?** screen.

- **NO** to return to the **ANT GO POSITION?** screen.

Setting antenna move step

1. Carry out the Enter setup mode procedure to display the **SET SAT PAIR?** screen.
2. Press the **PREV** soft key four times to display the **ANT MOVE STEP?** screen.
3. Press **YES** to display the **STEP AZ** control screen.
4. Use the **CCW** or **CW** soft keys to step the antenna counter-clockwise or clockwise, to the required horizontal direction. The horizontal angle is displayed on the top line.
5. When you have set the required horizontal direction, press the **EL** soft key to display the **STEP EL** control screen.
6. Use the **DOWN** or **UP** soft keys to step the antenna, to the required horizontal direction. The vertical angle is displayed on the top line.
7. To leave the antenna move step mode, press the **EXIT** soft key to return to the **ANT MOVE STEP?** screen.

3.4 Applying factory default values

If you want to return all settings to the factory default values, use the following procedure:

1. Carry out the Enter setup mode procedure to display the **SET SAT PAIR?** screen.
2. Press the **PREV** soft key once to display the **SET DEFAULT?** screen.
3. Press **YES**.

The message **DEFAULT SETTING** is displayed and the parameter values are reset. When the procedure is complete, the **SETUP MODE?** entry screen is displayed.

4. Press either:
 - **YES** if you want to change the setup values, or
 - **NO** to re-initialize the system using the default settings.

3.5 System information

You can use the ACU to display system product serial numbers and software versions.

The procedure for doing this is described as part of the maintenance procedures.

3.6 Checking system power

1. Carry out the Enter setup mode procedure to display the **SET SAT PAIR?** screen.
2. Press the **NEXT** soft key seven times to display the **VIEW POWER?** screen. The following information is displayed:

The following information is displayed sequentially:

- **ACU POWER**
- **ANT POWER** (antenna power)
- **IRD** power.

3. To leave the power display, press the **EXIT** soft key.

The **SETUP MODE?** entry screen is then displayed.

4. Press either:

- **YES** if you want to use another setup function, or
- **NO** to re-initialize the system.

3.7 Skew angle

If you need to improve your satellite signal reception, you may be able to do so by adjusting the skew angle. Before attempting to do this, seek advice from your service provider.

Note: Before attempting to adjust the skew angle ensure all power to the STV system is switched off. DO NOT attempt to set the skew angle with power applied.

Setting the skew angle

Contact your service provider to obtain the optimum skew angle for your geographical area.

Note: Factory default skew angle settings are:

- For the USA: 0°
- For the EU: -8°

To set the skew angle:

1. Ensure that all power to the system is switched off.
2. Remove and retain the bolts and washers securing the antenna dome.
3. Remove the antenna dome and store in a safe place.
4. At the rear of the reflector, identify the four screws that secure the LNB, to the reflector, then loosen the screws just sufficiently to enable the LNB to be rotated, as shown in the illustration.

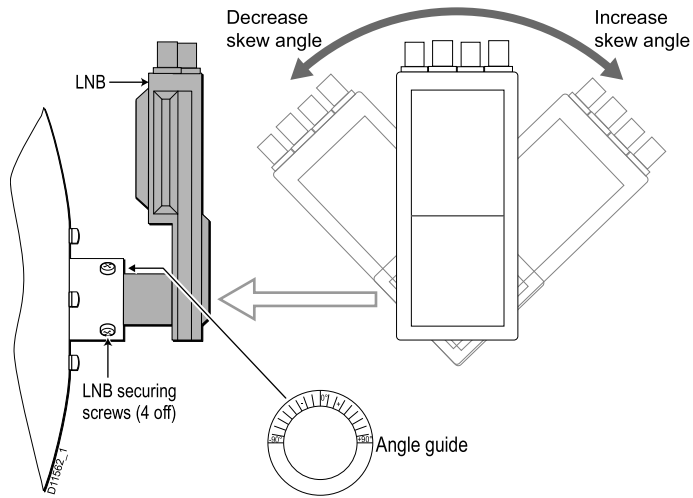

5. Rotate the LNB as necessary to set it to the skew angle recommended by your service provider.
6. Secure the LNB by tightening the four screws released at step 4.
7. Replace the antenna dome and secure it with the screws and washers retained at step 2.

3.8 Graphical user interface

Graphical User Interface (GUI) software is provided on the CDROM supplied with your components. When installed on a Personal Computer (PC) it enables you to operate your ACU from the computer. To do this, it must be connected to a relevant data port on the computer, using the supplied PC data cable.

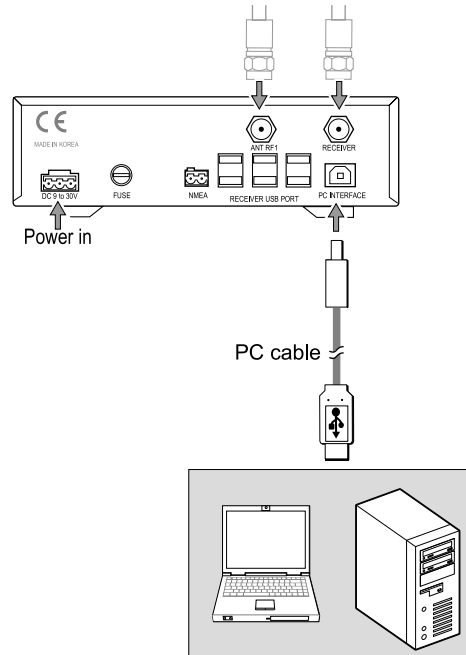

You can use the GUI for the majority of operating and setup functions.

Chapter 4: Maintenance & troubleshooting

Chapter contents

- [4.1 Maintenance on page 42](#)
- [4.2 Troubleshooting on page 42](#)
- [4.3 Raymarine technical support on page 44](#)

4.1 Maintenance



Warning: Switch off power

Before commencing any maintenance task, switch off all power to the product.

Maintenance procedures

Although your Raymarine Satellite TV system require minimal maintenance, ensure that your system maintains peak performance by carrying out the following maintenance tasks on a routine basis:

- Examine cables for signs of damage such as chafing or cuts.
- Check that all cables are securely connected.
- Wash the exterior of the antenna cover with fresh water to remove salt deposits; a mild detergent may be added to remove grime.
 - DO NOT use abrasive cleaners or solvents such as acetone as this may result in irreparable damage to the unit.
 - The antenna is not a sealed unit, so DO NOT use a power spray to wash the exterior as this may result in water ingress and damage to the unit.
- Twice a year remove the antenna dome and examine the antenna assembly for signs of corrosion.

4.2 Troubleshooting

Your Raymarine product has been subjected to comprehensive test and quality assurance programs prior to packing and shipping. However, should the product develop a fault, refer to the following table and list (below) to identify a possible cause and corrective action to help restore normal operation.

If you still have a problem after referring to the table, contact your local Raymarine dealer, national distributor or Raymarine Product Support for further advice.

Symptom	Possible cause							
	1	2	3	4	5	6	7	8
Antenna not functioning	X				X			
Display shows 'ANT OUT OF CONTROL' message	X				X			
No picture on TV			X		X	X		X
Intermittent picture for short intervals		X	X	X	X	X		X
System works at the dock but not under way		X						
System will not find satellite		X	X	X	X	X	X	X
'Snowy' television picture				X				

1. Blown fuse, low power or wiring. Check that:

- The in-line quick blow fuse (if fitted) has not blown, or the circuit breaker has not tripped. If the fuse has blown, replace it with one of the same type and rating.
- There are no damaged wires and/or insecure connections.

- There is no power loss through the cable from the **RF1** connector on the antenna unit, particularly if this cable has been extended.

2. Satellite signal blocked.

Check that the antenna has a clear view of the sky. Satellite signals can be blocked or degraded by buildings, other boats, or equipment on your boat.

3. Outside satellite coverage zone.

Your system will provide excellent reception within the antenna coverage area for your satellite television service. However, signal quality may degrade as you approach the edges of this zone. Refer to the information on “Satellite coverage areas” to check the viable coverage area for your antenna.

4. Radar interference.

The energy levels radiated by radar units can overload the antenna circuits. Ensure that your antenna is installed as described in accordance with the with regards correctly with respect to your radar unit, as described in the planning information for STV.

5. Incorrect or loose RF connectors.

All connections should be checked as part of the regular maintenance recommended by Raymarine, to ensure that they have not become loose. A loose RF connector can reduce signal quality or cause the antenna not to work.

6. Multi-switch interference.

If you have multiple IRD’s connected to your system, make sure that you are using an ACTIVE not PASSIVE multi-switch.

7. IRD troubleshooting.

Your IRD may be the cause of unsatisfactory operation. Check the IRDs configuration to ensure it is programmed for the area in which you are operating. Unplug the IRD from the power supply for 15 seconds, then reconnect and allow the system to initialize.

8. LNB fault.

If you have an LNB fault, contact your local dealer, national distributor or Raymarine Product Support for further assistance, The LNB may require replacing.

Antenna diagnosis procedure

To run the antenna diagnosis:

1. Carry out the Enter setup mode procedure to display the **SET SAT PAIR?** screen.
2. Press the **PREV** soft key three times to display the **ANT DIAGNOSIS?** screen.
3. Press **YES** to start the diagnosis routine.

The diagnosis routine runs automatically, carrying out a series of tests designated **CODE 101** to **CODE 110**. As each test completes, check the result indication:

?	Test running
—	Test skipped
•	Test passed
A number	Test failed

4. When the **DIAGNOSIS COMPLETE** screen is displayed, press the **EXIT** soft key to return to the **SETUP MODE?** entry screen. For further assistance contact your local dealer or Raymarine technical support.

4.3 Raymarine technical support

Raymarine provides a comprehensive customer support service, on the world wide web, through our worldwide dealer network and by telephone help line. If you are unable to resolve a problem, please use any of these facilities to obtain additional help.

Web support

Please visit the customer support area of our website at:

www.raymarine.com

This contains Frequently Asked Questions, servicing information, e-mail access to the Raymarine Technical Support Department and details of worldwide Raymarine agents.

Telephone support

In the USA call:

+1 603 881 5200 extension 2444

In the UK, Europe, the Middle East, or Far East call:

+44 (0)23 9271 4713

Product information

If you need to request service, please have the following information to hand:

- Product name.
- Product identity.
- Serial number.
- Software application version.

You can obtain this product information using the menus within your product.

Checking serial numbers & software versions

Use this procedure to see product serial numbers and software versions.

1. Carry out the Enter setup mode procedure to display the **SET SAT PAIR?** screen.
2. Press the **NEXT** soft key six times to display the **VIEW VERSION?** screen. The following information is displayed:

The following information is displayed sequentially:

- The antenna product name.
 - The antenna serial number.
 - The antenna software version.
 - The ACU software version.
 - The library version.
3. To leave the information display, press the **EXIT** soft key. The **SETUP MODE?** entry screen is then displayed.
 4. Press either:
 - **YES** if you want to use another setup function, or
 - **NO** to re-initialize the system.

Chapter 5: Satellite information

Chapter contents

- [5.1 Introduction on page 46](#)
- [5.2 Satellite coverage on page 46](#)
- [5.3 Satellite providers on page 47](#)
- [5.4 Satellite tracking data on page 49](#)

5.1 Introduction

This section contains satellite and tracking information and includes:

- Summaries of satellites and service providers for the different geographic locations.
- Satellite tracking information

5.2 Satellite coverage

As satellite signals can be affected by climatic conditions and by solar activity (sun spots, solar flares), the coverage is not guaranteed.

Refer to the individual satellite providers home page for up to date information and coverage maps for satellites.

Note: Reception is affected by climatic conditions, the coverage indicated by providers is not guaranteed.

Climatic conditions

Climatic conditions that can cause a significant reduction of signal level include:

- Rain
- Snow
- Thick fog

The most common of these conditions is rain, which will reduce the signal from the satellite. The heavier the rain the higher the signal loss.

The effect of this signal loss is that the antenna's ability to remain locked to the satellite signal becomes severely affected. This in turn means degradation or in some cases a complete loss of satellite signal.

When the amount of rain in the atmosphere decreases the antenna will reacquire the satellite signal.

5.3 Satellite providers

To receive a satellite television service you need to subscribe to the service from the relevant service provider.

Satellite providers - United States of America

Satellites	Service provider
NIMIQ1 - NIM001KB NIMIQ2 - NIM002KB	Bell ExpressVu www.expressvu.com
EchoStar 3 - ECH003KB EchoStar 6.8 - ECH008KB EchoStar 7 - ECH007KB EchoStar 1.2 - ECH001KB	EchoStar Communications Corp. www.dishnetwork.com
DIRECTV - DTV101 DIRECTV - DTV119	DirecTV Inc. www.directv.com

Satellite providers - Europe

Country	Satellites	Service provider
England	Astra - AST 02AS0 Astra - AST02AN0	Astra www.ses-astra.com

Germany	Primary: <ul style="list-style-type: none"> Astra - AST01GKU Secondary (limited channels) <ul style="list-style-type: none"> Hotbird - HOT234KW Astra - AST01EH1 Astra - AST01FH1 Astra - AST01EV1 	Astra www.ses-astra.com Hotbird www.eutelsat.com
France	Hotbird - HOT234KS Hotbird - HOT234KW Astra - AST101GKU	Hotbird www.eutelsat.com Astra www.ses-astra.com
Spain	Primary: <ul style="list-style-type: none"> Astra - AST01GKU Secondary (limited channels) <ul style="list-style-type: none"> Hispasat - HIS01AKS Hispasat - HI01CKS Hotbird - HOT234KW Astra - AST01EV1 	Astra www.ses-astra.com Hispasat www.hispasat.com Hotbird www.eutelsat.com
Italy	Hotbird - HOT234KS Hotbird - HOT234KW	Hotbird www.eutelsat.com

Scandinavia	Primary: <ul style="list-style-type: none"> • Sirius - SIR002KN • Thor - THO002KU Secondary (limited channels) <ul style="list-style-type: none"> • Sirius - SIR003KN • Thor - THO001KU • Thor - THO003KU 	Sirius www.nsab.se Thor www.telenor.com
Turkey	Hotbird - HOT234KW Turksat - TUR01BKT Turksat - TUR01CEB	Hotbird www.eutelsat.com Turksat www.satcom.gov.tr
Russia	Thor - THO003KU Hotbird - HOT234KW	Thor www.telenor.com Hotbird www.eutelsat.com
Greece	Hotbird - HOT234KW	Hotbird www.eutelsat.com

5.4 Satellite tracking data

Your Raymarine Satellite TV System can track a variety of DVB compatible and DSS (DIRECTV) satellites. Your system contains a pre-programmed library of data for the range of satellites applicable to your system.

Refer to the tables provided if you need to manually enter data for tracking satellites.

Important: Please be aware that, satellite tracking data is dependent on the service providers and can change without notice. Therefore we do not guarantee the information in this section; it is provided for reference only.

North American Satellites

Satellite name	Frequency	Transponder symbol rate	FEC code	Satellite network ID	LNB polarization (right- or left-handed circular)	LNB band	Decoding type
ExpressVu91	12428 12443	20000 20000	5/6 5/6	0x0100 0x0100	RHCP LHCP	U U	DVB DVB
ExpressVu82	12428 12443	20000 20000	5/6 5/6	0x0101 0x0101	RHCP LHCP	U U	DVB DVB
EchoStar61	12632 12443	20000 20000	3/4 5/6	0x1002 0x1002	RHCP LHCP	U U	DVB DVB
EchoStar110	12428 12443	20000 20000	5/6 5/6	0x1006 0x1006	RHCP LHCP	U U	DVB DVB
EchoStar119	12428 12443	20000 20000	5/6 5/6	0x1004 0x1004	RHCP LHCP	U U	DVB DVB
EchoStar148	12428 12443	20000 20000	5/6 5/6	0x1009 0x1009	RHCP LHCP	U U	DVB DVB
DirecTV73	12370 12355	20000 20000	2/3 2/3	0xFFF7 0xFFF7	RHCP LHCP	U U	DSS DSS
DirecTV101	12428 12443	20000 20000	6/7 6/7	0xFFF0 0xFFF0	RHCP LHCP	U U	DSS DSS
DirecTV119	12428 12443	20000 20000	5/6 5/6	0x1004 0x1004	RHCP LHCP	U U	DVB DVB

European Satellites

Satellite name	Frequency	Transponder symbol rate	FEC code	Satellite network ID	LNB polarization (vertical or horizontal)	LNB band	Decoding type
Astra 1	10788 10773 11895 12032	22000 22000 27500 27500	5/6 5/6 3/4 3/4	0x0001 0x0001 0x0001 0x0085	V H V H	L L H H	DVB DVB DVB DVB
Astra 2	10788 10773 11895 11954	22000 22000 27500 27500	5/6 5/6 2/3 2/3	0x0020 0x0020 0x0020 0x0020	V H V H	L L H H	DVB DVB DVB DVB
Hispasat	11771 11811 12303 11851	27500 27500 27500 27500	3/4 3/4 3/4 3/4	0x0031 0x0036 0x0031 0x0036	V H V H	L L H H	DVB DVB DVB DVB
Hotbird	11623 11642 11958 11977	27500 27500 27500 27500	3/4 3/4 3/4 3/4	0x013E 0x013E 0xFBFF 0xFBFF	V H V H	L L H H	DVB DVB DVB DVB
Sirius	11747 11804 12054 12034	27500 27500 27500 27500	3/4 3/4 3/4 3/4	0x0056 0x0056 0x0056 0x0056	V H V H	L L H H	DVB DVB DVB DVB
Thor	11216 11229 12456 12476	24500 24500 28000 28000	7/8 7/8 3/4 3/4	0x0046 0x0046 0x0046 0x0046	V H V H	L L H H	DVB DVB DVB DVB

Arabsat	11747	27500	3/4	0x02BE	V	H	DVB
	11662	27500	3/4	0x002C	V	L	DVB
	11843	27500	3/4	0x02BE	H	H	DVB
	11642	27500	3/4	0x02BE	H	L	DVB
Nilesat	11900	27500	3/4	0x0800	V	H	DVB
	00000	27500	3/4	0x0000	V	L	DVB
	11996	27500	3/4	0x0800	H	H	DVB
	00000	27500	3/4	0x0000	H	L	DVB
Turksat	11804	24444	5/6	0x0042	V	H	DVB
	11804	24444	5/6	0x0042	V	L	DVB
	11892	12800	5/6	0x0049	H	H	DVB
	11892	12800	5/6	0x0049	H	L	DVB

Australian & New Zealand Satellites

Satellite name	Frequency	Transponder symbol rate	FEC code	Satellite network ID	LNB polarization (vertical or horizontal)	LNB band	Decoding type
Optus B1	12608 12456	22500 22500	3/4 3/4	0x00B6 0x00B6	V H	U U	DVB DVB
Optus C1	12447 12358	27800 27800	3/4 3/4	0x1000 0x1000	V H	U U	DVB DVB

Far East Satellites

Satellite name	Frequency	Transponder symbol rate	FEC code	Satellite network ID	LNB polarization (vertical or horizontal)	LNB band	Decoding type
Agila2	12301	25600	5/6	0x0039	H	L	DVB
Telstar 10	12528 12551	30000 13338	3/4 3/4	0x0001 0x0001	V H	U U	DVB DVB
Telstar 18	12538	41250	1/2	0x0378	V	H	DVB

Chapter 6: Technical Specification

Chapter contents

- [6.1 Technical specification on page 56](#)

6.1 Technical specification

General

Approvals

CE - Conforms to EU Directive 89/336/EEC

Dimensions

Satellite antenna unit: 370 mm x 380 mm (14.6 x 15 ins.)

Antenna dish diameter: 330 mm (13.3 ins.)

Antenna control unit: 178 mm x 217 mm x 54 mm (7 x 8.6 x 2.2 ins.)

Weight

Satellite antenna unit: 4.5 kg (9.9 lbs.)

Antenna control unit: 1.2 kg (2.7 lbs)

Environmental

Operating temperature range: -15°C to + 55°C (5°F to 131°F)

Storage temperature range: -25°C to + 70°C (-4°F to 158°F)

Humidity limit: 95% R.H

Electrical

Operating voltage: 9 V to 30 V dc

Power consumption: 30 W typical

Antenna system

Frequency: Ku-band (10.7 to 12.75 GHz).

Antenna gain: 30.5 dBi @ 11.7 GHz.

Minimum EIRP: 51 dBW.

Azimuth range: 680°.

Elevation range: 10° to 80°.

Roll range: ±25°.

Pitch range: ±15°.

Roll and pitch tracking: 60° per second.

Roll and pitch rate: 60° per second.

Index

A

ACU rear connectors	14
Antenna	
connectors	14
installing	18
manually directing	36
setting go position	36
setting move step	36
monitoring operation	27
position	15
remove packing restraints	18
setting parameters	33
Antenna Control Unit	
connectors	14
controls	14
Installing	19
position	15

C

Cables routing requirement	16
CDROM	13
Checking	
serial numbers	44
software version	44
system power	38

P

Packing restraints	18
Power	
checking	38
supply requirement	16

R

Routine maintenance	42
---------------------------	----

S

Satellite coverage	
limitations	46
Satellite tracking data	
Australian & New Zealand	53
European	51
Far East	54
North American	50
Serial numbers	44
Setup	
antenna parameters	33
applying factory default values	37
default satellites	30
DiSEqC method	35
editing satellite information	32
editing screens	29
entering setup mode	29
GPS	31
LNB local frequency	34
single band	35
universal	35
operating region	29
skew angle	38
using ACU buttons	29
Software versions	44
Startup sequence	27
System options	
basic system	20
connecting to NMEA 0183 GPS	23

multiple IRDs.....	22
two IRDs	21

T

Target satellite	
changing	27
Troubleshooting	42
antenna diagnosis	43
obtaining serial numbers.....	44
obtaining software version numbers	44

Raymarine[®]

www.raymarine.com

CE