

Item Number

RAM-VB-129 & RAM-VB-129-SW1

RAM No-Drill™ Seat Bases

National Products, Inc.

COMPATIBLE VEHICLES:

DODGE CHARGER (2005, 2011-2013)
DODGE CHARGER POLICE (2005, 2011-2013)
DODGE MAGNUM (2005)
DODGE MAGNUM POLICE (2005)

DODGE CHALLENGER (2011)
DODGE SPRINTER VAN (2007-2010)
FREIGHTLINER SPRINTER VAN (2010-2011)
MERCEDES SPRINTER VAN (2010-2013)

SPECIFICATIONS

Placement

Passenger side on horizontal section of seat rail. For Sprinter, between seat cushion and seat frame box passenger side front of seat

Drilling Required

No - uses existing seat bolts

Seat Configuration

Bucket

Construction/Finish

Steel/Black Powdercoat

Dimensions

A = 19.375" B = 7.125"
Hole Center = 16.5"

Pole or Pedestal

Purchased Separatel

Weight = 4.9 lbs.

Features

Installs with no drilling required
Minimal intrusion into passenger leg space

Important Note

In 2005 and 2011 model year vehicles, the seat leg bolts may be tied to the air bag system. Tampering with these may result in disabling the air bag system and causing a severe safety hazard. The installation of this product into these vehicles should only be done by a Dodge factory authorized technician or Up-fitter familiar with Police, Fire, and Rescue vehicles and their fleet use.

National Products, Inc.

8410 Dallas Ave S
Seattle, WA 98108
Phone: (206) 763-8361
Fax: (206) 763-9615
Website: www.ram-mount.com
Email: staff@ram-mount.com



RAM-VB-129-SW1

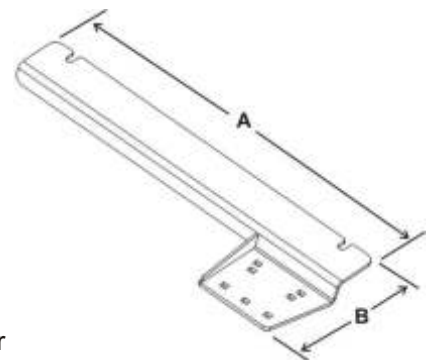

RAM-VB-129



Item Number

RAM-VB-129 & RAM-VB-129-SW1

RAM No-Drill™ Seat Bases

National Products, Inc.

COMPATIBLE VEHICLES:

DODGE CHARGER (2005, 2011-2013)
DODGE CHARGER POLICE (2005, 2011-2013)
DODGE MAGNUM (2005)
DODGE MAGNUM POLICE (2005)

DODGE CHALLENGER (2011)
DODGE SPRINTER VAN (2007-2010)
FREIGHTLINER SPRINTER VAN (2010-2011)
MERCEDES SPRINTER VAN (2010-2013)

INSTALLATION INSTRUCTIONS

For the Dodge Charger you will need an E12 socket. If you are using a RAM Tele-Pole system, attach the lower female tube prior to installing the no drill base in the vehicle. It is suggested to install the mounting hardware so the rubber nut caps are on the top side.

1. Loosen the seat leg bolts on the passenger side that hold the seat to the floor pan. These are located at the front center of the seat tracks. It is not necessary to remove these. Only loosen them enough to clear the no drill base.
2. Once the bolts are loose, gently lift the front of the seat to create enough space for the base to fit between the seat frame legs and floor board.
3. Align the slots with the seat leg bolts and slide the base completely under the legs until the back of the slots contacts the seat leg bolts.
4. Fully tighten the seat leg bolts to secure the no drill base in place.

For installation into Vans, the slots are not used but the holes instead.

1. Remove the two seat bolts holding the seat tracks to the seat frame box.
2. Place the base between the seat tracks and seat frame box and align the holes. Replace the seat bolts and fully tighten.



National Products, Inc.

8410 Dallas Ave S
Seattle, WA 98108
Phone: (206) 763-8361
Fax: (206) 763-9615
Website: www.ram-mount.com
Email: staff@ram-mount.com

