

# Motorised Battery Switch

Model: 701-MD

Operation and Installation  
Instructions



Manufactured by **BEP Marine Ltd.**  
13 Tamdale Grove, Albany,  
Auckland, New Zealand.  
Phone (+649)4157261  
Fax. (+649)4159327



**Introduction:** The Motorised Battery Switch (701-MD) has the same mechanism as the well proven 701. The essential difference being the switching action has been motorised.

This permits switching of battery banks remotely. A typical installation is a key operated switch at the helm station and the motorised battery switch installed as close as practical to the battery bank. (Part No for key switch: 722-KS or any other standard On/Off switch)

Apart from the convenience of such an installation, this arrangement permits much shorter cable runs to starter motors and other high current applications such as bow thrusters and inverters. As a result voltage drop and use of heavy cable has been kept to minimum.

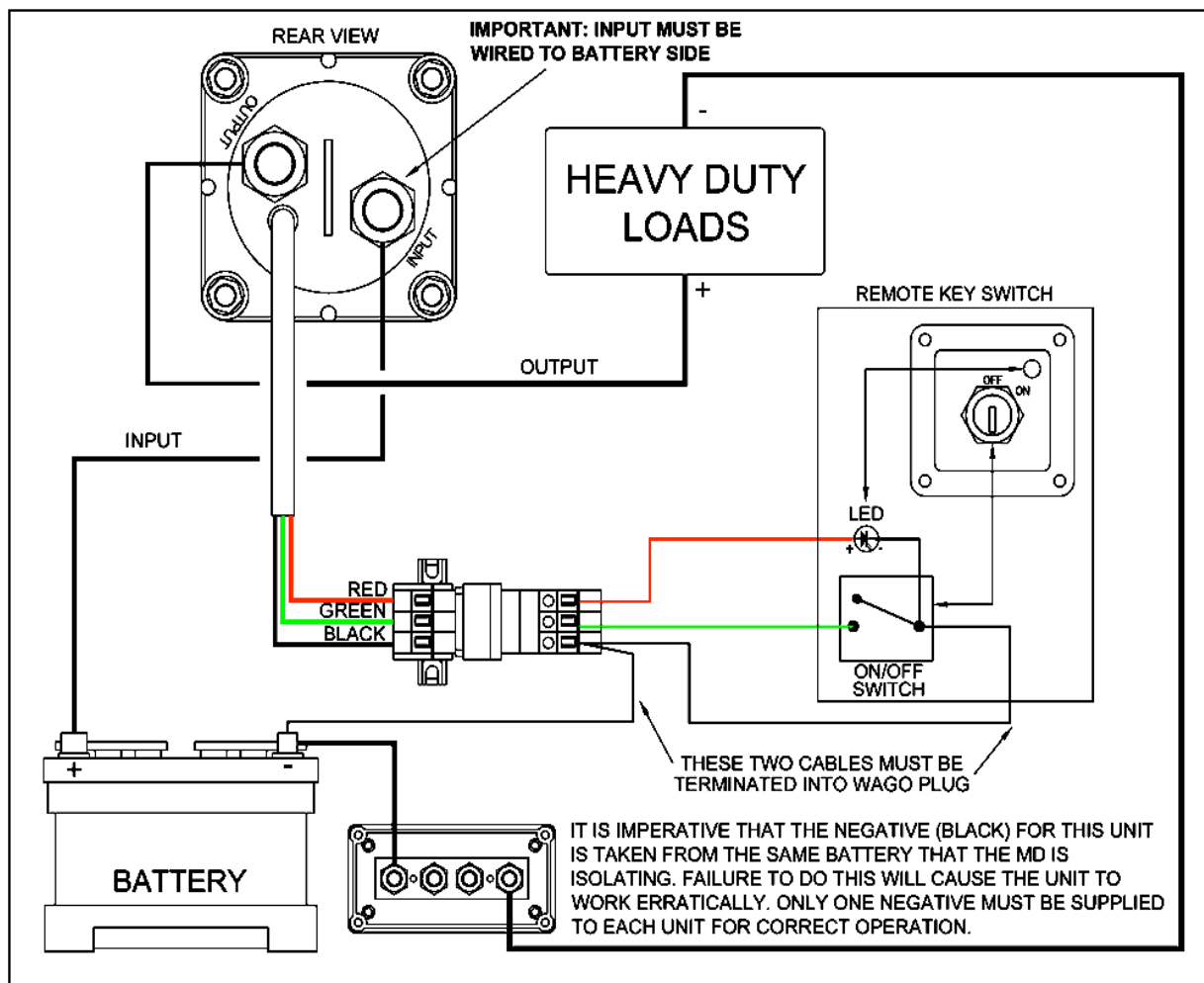

**Specifications:**

- **Continuous rating:** 275 Amps DC
- **Intermittent rating:** 455 Amps DC
- **Cranking rating:** 1250 Amps DC
- **Maximum Voltage:** 32 Volts DC
- **Operation:** Manual On/Off  
Motorised On/Off
- **Mounting:** Recessed or surface
- **Auto operating range** 8 to 30 Volts DC

- **Ignition protected**
- **Stud Size:** 2 x 10mm(3/8")
- **Tin plated copper studs and nuts**
- **Power draw:**  
Switch in off position: 15mA
- **Recommended Maximum Cable Size:** 50mm.  
If fitting cable in excess of 50mm the cable must be strain relieved with an absolute maximum of 00 or 70mm.

**General Operation:** The Motorised Battery Switch, (701-MD) has two modes of operation. Auto and Manual. There is a LED located on both the battery switch and key switch (722-KS), Indicating Battery Switch status.

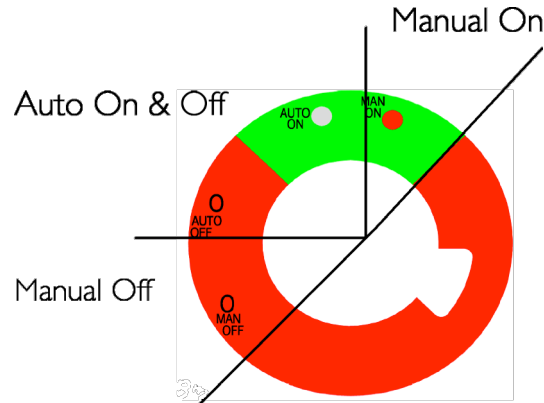

**Auto Operation:** The 701-MD moves from a state of “Auto Off” to “Auto On” when the remotely mounted switch is turned on. During the time that the battery switch is in “Auto On” mode, the “Auto On” LED is illuminated.

Auto operation of the Battery Switch is not possible whilst in manual mode. If auto operation is attempted, the LED will flash for 3 seconds then stop. Knob must be returned to “Auto Off” before normal auto operation can continue.

**Manual Operation:** The automatic operation of the 701-MD battery switch can be overridden at anytime by **depressing the control knob** and turning clockwise towards the “Man On” position or counter clockwise towards the “Man Off” position. During the time that the Battery switch is in “Man On” mode, the “Man On” LED is illuminated. **Refer Fig 1 for reference.**

**Battery Switch Labels.**

The Motorised battery switch is supplied with a generic battery label. A range of the most commonly used labels can be ordered separately. **Part No. 713**

**Auto Mode LED Indications:**

- LED OFF:** Battery switch is off
- LED ON:** Battery switch is on
- LED FLASHING:** LED flashes whilst moving between auto on and auto off.
- LED Rapid Flash: On 0.1 sec & Off 0.1 Sec:** Voltage is outside specification i.e. Less than 8 Volts or greater than 30 Volts

**Manual Mode LED Indications:**

- LED OFF:** Battery Switch is off
- LED ON:** Battery Switch is on

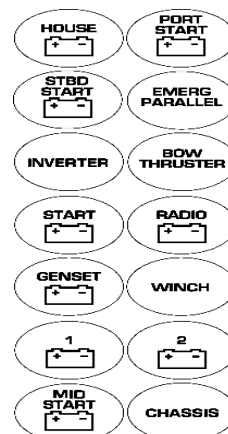

Part No. 713

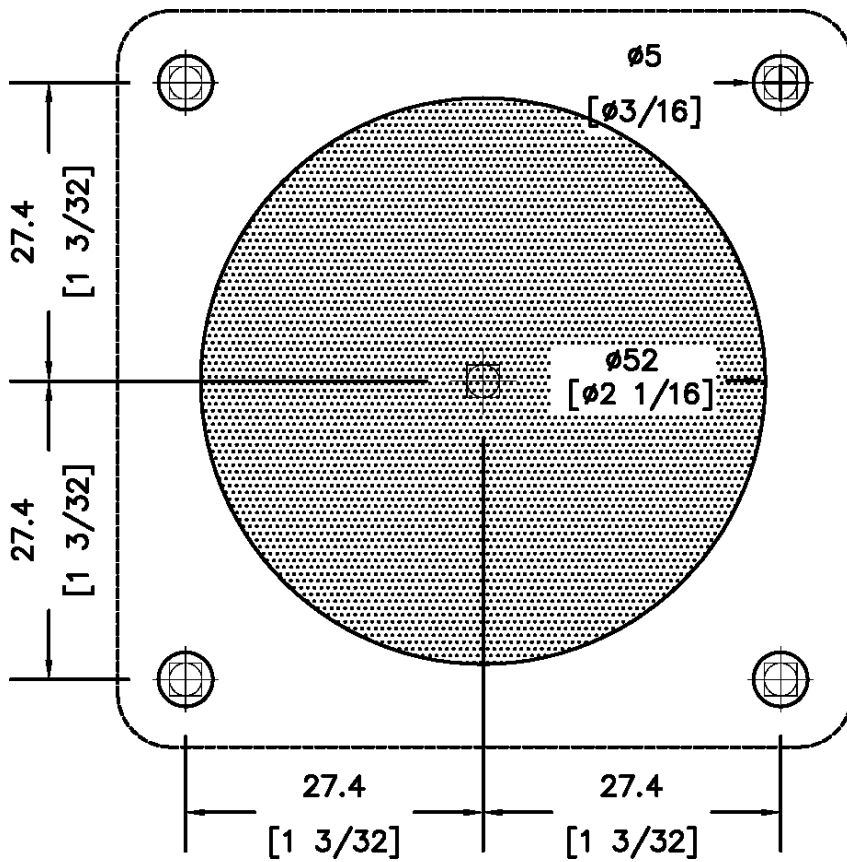
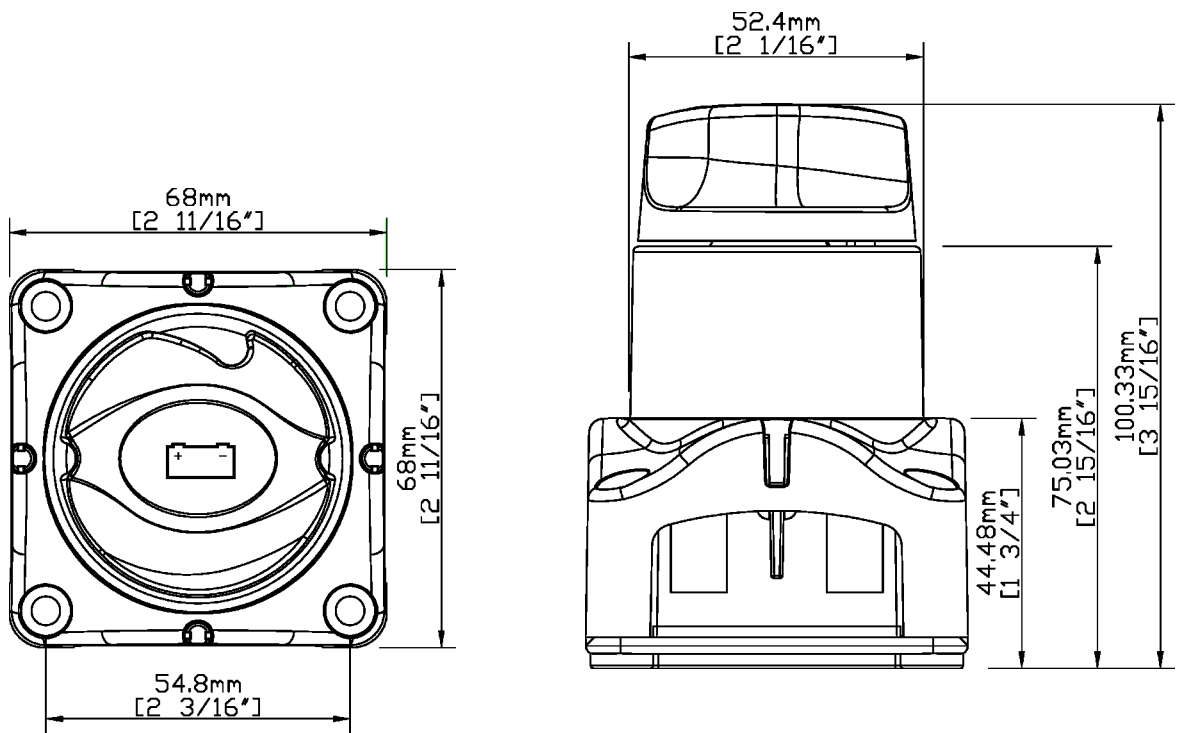

**Cut Out Template**