

Raymarine®



ELEMENT™

Installation instructions

English (en-US)
Date: 06-2019
Document number: 87360-4
© 2019 Raymarine UK Limited

Trademark and patents notice

Raymarine, Tacktick, Clear Pulse, Truzoom, SeaTalk, SeaTalk^{hs}, SeaTalkng, and **Micronet**, are registered or claimed trademarks of Raymarine Belgium.

FLIR, LightHouse, DownVision, SideVision, RealVision, HyperVision, Dragonfly, Element, Quantum, Axiom, Instalert, Infrared Everywhere, The World's Sixth Sense and **ClearCruise** are registered or claimed trademarks of FLIR Systems, Inc.

All other trademarks, trade names, or company names referenced herein are used for identification only and are the property of their respective owners.

This product is protected by patents, design patents, patents pending, or design patents pending.

Fair Use Statement

You may print no more than three copies of this manual for your own use. You may not make any further copies or distribute or use the manual in any other way including without limitation exploiting the manual commercially or giving or selling copies to third parties.

Software updates



Check the Raymarine website for the latest software releases for your product.
www.raymarine.com/software

Product documentation



The latest versions of all English and translated documents are available to download in PDF format from the website: www.raymarine.com/manuals.
Please check the website to ensure you have the latest documentation.

Publication copyright

Copyright ©2019 Raymarine UK Ltd. All rights reserved.

Contents

Chapter 1 Important information	9
Disclaimers	9
RF exposure	10
Compliance Statement (Part 15.19)	10
FCC Interference Statement (Part 15.105 (b))	10
Innovation, Science and Economic Development Canada (ISED)	10
Innovation, Sciences et Développement économique Canada (Français).....	10
Declaration of conformity.....	11
Product disposal	11
Warranty registration	11
Technical accuracy	11
Chapter 2 Document and product information	13
2.1 Document information	14
Applicable software version	14
Product documentation	14
Document illustrations	15
2.2 Applicable products.....	16
2.3 Product overview	17
2.4 Compatible transducers - Element HV displays.....	18
HyperVision™ transducers.....	18
Third party transducers.....	18
Compatible legacy transducers	18
2.5 Compatible transducers - Element S displays.....	20
High CHIRP sonar transducers	20
2.6 Optional additional components.....	21
Data compatibility	21
Compatible engine systems	21
Compatible tank level sensors.....	22
2.7 Parts supplied	23
Chapter 3 Installation	25
3.1 Selecting a location.....	26
General location requirements	26
GPS/GNSS location requirements	27
Wireless location requirements	27
EMC installation guidelines.....	27
3.2 Product dimensions	29
3.3 Mounting options.....	30
3.4 Trunnion bracket mounting.....	31
3.5 Surface mounting	32
Chapter 4 Connections	35

4.1 Connections Overview	36
4.2 General cabling guidance	38
Cable types and length.....	38
Strain relief.....	38
Cable shielding	38
Making connections.....	38
4.3 Power connection	39
In-line fuse and thermal breaker ratings	39
Grounding — Dedicated drain wire.....	40
Power distribution.....	40
4.4 Element™ HV transducer connection	44
HV–100 transducer extension cable.....	45
HV–300 transducer extension cable.....	45
Cable routing	46
4.5 Element™ HV legacy transducer connection.....	47
Legacy transducer extension cables	47
4.6 Element™ S transducer connection	48
4.7 SeaTalkng® connection	49
Data compatibility	49
NMEA 2000 connection	49
4.8 SeaTalkng® system example	50
4.9 Pairing a Quantum™ radar scanner.....	52
4.10 Element autopilot connection	53
Chapter 5 Maintaining your display	55
5.1 Service and maintenance.....	56
5.2 Product care.....	57
Routine equipment checks	57
Cleaning the display case.....	57
Cleaning the display screen	57
Cleaning the sun cover.....	57
Chapter 6 Troubleshooting	59
6.1 Troubleshooting	60
6.2 Power up troubleshooting	61
Performing a power on reset.....	61
6.3 GPS / GNSS troubleshooting	63
6.4 Sonar troubleshooting.....	64
6.5 Wi-Fi troubleshooting	66
Chapter 7 Technical support.....	69
7.1 Raymarine product support and servicing	70
Viewing hardware and software details (LightHouse™ Sport)	71
Viewing product information	71

7.2 Learning resources	73
Chapter 8 Technical specification.....	75
8.1 Element technical specification.....	76
8.2 HyperVision™ technical specification.....	77
8.3 Internal GNSS (GPS / GLONASS) receiver specification	78
8.4 Conformance specification	79
Chapter 9 Spares and accessories	81
9.1 Spares.....	82
9.2 Element accessories.....	83
9.3 Compatible transducers - Element HV displays.....	84
HyperVision™ transducers.....	84
Third party transducers.....	84
Compatible legacy transducers	84
9.4 Compatible transducers - Element S displays	86
High CHIRP sonar transducers	86
9.5 SeaTalkng® cables and accessories.....	87
Appendix A NMEA 2000 PGNs	89
Appendix B Document change history.....	91

Chapter 1: Important information



Warning: Product installation and operation

- This product must be installed and operated in accordance with the instructions provided. Failure to do so could result in personal injury, damage to your vessel and/or poor product performance.
- Raymarine recommends certified installation by a Raymarine approved installer. A certified installation qualifies for enhanced product warranty benefits. Contact your Raymarine dealer for further details, and refer to the separate warranty document packed with your product.



Warning: Ensure safe navigation

This product is intended only as an aid to navigation and must never be used in preference to sound navigational judgment. Only official government charts and notices to mariners contain all the current information needed for safe navigation, and the captain is responsible for their prudent use. It is the user's responsibility to use official government charts, notices to mariners, caution and proper navigational skill when operating this or any other Raymarine product.



Warning: Potential ignition source

This product is NOT approved for use in hazardous/flammable atmospheres. Do NOT install in a hazardous/flammable atmosphere (such as in an engine room or near fuel tanks).



Warning: 12 Volt dc only

This product must only be connected to a **12 volt dc** power source.



Warning: High voltages

This product may contain high voltages. Do NOT remove any covers or otherwise attempt to access internal components, unless specifically instructed in the documentation provided.



Warning: Switch off power supply

Ensure the vessel's power supply is switched OFF before starting to install this product. Do NOT connect or disconnect equipment with the power switched on, unless instructed in this document.

Disclaimers

Raymarine does not warrant that this product is error-free or that it is compatible with products manufactured by any person or entity other than Raymarine.

This product uses digital chart data, and electronic information from Global Navigation Satellite Systems (GNSS) which may contain errors. Raymarine does not warrant the accuracy of such information and you are advised that errors in such information may cause the product to malfunction. Raymarine is not responsible for damages or injuries caused by your use or inability to use the product, by the interaction of the product with products manufactured by others, or by errors in chart data or information utilized by the product and supplied by third parties.

This product supports electronic charts provided by third party suppliers which may be embedded or stored on memory card. Use of such charts is subject to the supplier's End-User Licence Agreement.

RF exposure

This equipment complies with FCC / IC RF exposure limits for general population / uncontrolled exposure. The wireless LAN / Bluetooth antenna is mounted behind the front facia of the display. This equipment should be installed and operated with a minimum distance of 1 cm (0.39 in) between the device and the body. This transmitter must not be co-located or operating in conjunction with any other antenna or transmitter, except in accordance with FCC multi-transmitter product procedures.

Compliance Statement (Part 15.19)

This device complies with Part 15 of the FCC Rules. Operation is subject to the following two conditions:

1. This device may not cause harmful interference.
2. This device must accept any interference received, including interference that may cause undesired operation.

FCC Interference Statement (Part 15.105 (b))

This equipment has been tested and found to comply with the limits for a Class B digital device, pursuant to Part 15 of the FCC Rules.

These limits are designed to provide reasonable protection against harmful interference in a residential installation. This equipment generates, uses, and can radiate radio frequency energy and, if not installed and used in accordance with the instructions, may cause harmful interference to radio communications. However, there is no guarantee that interference will not occur in a particular installation. If this equipment does cause harmful interference to radio or television reception, which can be determined by turning the equipment off and on, the user is encouraged to try to correct the interference by one of the following measures:

1. Reorient or relocate the receiving antenna.
2. Increase the separation between the equipment and receiver.
3. Connect the equipment into an outlet on a circuit different from that to which the receiver is connected.
4. Consult the dealer or an experienced radio / TV technician for help.

Innovation, Science and Economic Development Canada (ISED)

This device complies with License-exempt RSS standard(s).

Operation is subject to the following two conditions:

1. This device may not cause interference; and
2. This device must accept any interference, including interference that may cause undesired operation of the device.

This Class B digital apparatus complies with Canadian ICES-003.

Innovation, Sciences et Développement économique Canada (Français)

Cet appareil est conforme aux normes d'exemption de licence RSS.

Son fonctionnement est soumis aux deux conditions suivantes:

1. cet appareil ne doit pas causer d'interférence, et
2. cet appareil doit accepter toute interférence, notamment les interférences qui peuvent affecter son fonctionnement.

Cet appareil numérique de la classe B est conforme à la norme NMB-003 du Canada.

Declaration of conformity

FLIR Belgium BVBA declares that the products listed below are in compliance with the EMC Directive 2014/30/EU:

- Element™ 7 HV, part numbers E70532
- Element™ 7 S, part numbers E70531
- Element™ 9 HV, part numbers E70534
- Element™ 9 S, part numbers E70533
- Element™ 12 HV, part numbers E70536
- Element™ 12 S, part numbers E70535

The original Declaration of Conformity certificate may be viewed on the relevant product page at www.raymarine.com

Product disposal

Dispose of this product in accordance with the WEEE Directive.

The Waste Electrical and Electronic Equipment (WEEE) Directive requires the recycling of waste electrical and electronic equipment which contains materials, components and substances that may be hazardous and present a risk to human health and the environment when WEEE is not handled correctly.

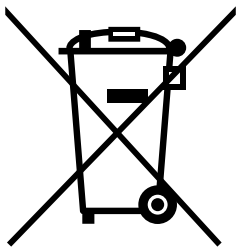

Equipment marked with the crossed-out wheeled bin symbol indicates that the equipment should not be disposed of in unsorted household waste.

Local authorities in many regions have established collection schemes under which residents can dispose of waste electrical and electronic equipment at a recycling center or other collection point.

For more information about suitable collection points for waste electrical and electronic equipment in your region, refer to the Raymarine website: www.raymarine.eu/recycling.



Warranty registration

To register your Raymarine product ownership, please visit www.raymarine.com and register online.

It is important that you register your product to receive full warranty benefits. Your unit package includes a bar code label indicating the serial number of the unit. You will need this serial number when registering your product online. You should retain the label for future reference.

Technical accuracy

To the best of our knowledge, the information in this document was correct at the time it was produced. However, Raymarine cannot accept liability for any inaccuracies or omissions it may contain. In addition, our policy of continuous product improvement may change specifications without notice. As a result, Raymarine cannot accept liability for any differences between the product and this document. Please check the Raymarine website (www.raymarine.com) to ensure you have the most up-to-date version(s) of the documentation for your product.

Chapter 2: Document and product information

Chapter contents

- 2.1 Document information on page 14
- 2.2 Applicable products on page 16
- 2.3 Product overview on page 17
- 2.4 Compatible transducers - Element HV displays on page 18
- 2.5 Compatible transducers - Element S displays on page 20
- 2.6 Optional additional components on page 21
- 2.7 Parts supplied on page 23

2.1 Document information

This document contains important information related to the installation of your Raymarine product. The document includes information to help you:

- plan your installation and ensure you have all the necessary equipment;
- install and connect your product as part of a wider system of connected marine electronics;
- troubleshoot problems and obtain technical support if required.

This and other Raymarine product documents are available to download in PDF format from www.raymarine.com/manuals.

Applicable software version

Product software is updated regularly to add new features and improve existing functionality. This document has been updated to reflect displays running version 3.9.98 of the LightHouse™ Sport operating system.

Check the website for the latest software and user manuals:

- www.raymarine.com/software
- www.raymarine.com/manuals

Product documentation

The following documentation is applicable to your product:

Documentation

Description	Part number
Element™ Sonar / GPS Combo Installation Instructions (this document)	87360
LightHouse™ Sport Basic Operation instructions.	81384
LightHouse™ Sport Advanced Operation instructions.	81388
HV-100 Transom Mount Plastic Transducer Installation Instructions	87362
HV-300TH / HV-300THP / HV-300THP-P / HV-300THP-S Thru-hull, Plastic Transducer Installation instructions	87391
ECI-100 Engine Gateway Installation Instructions	87202
Quantum™ Wi-Fi guidance	87270

All documents are available to download as PDFs from www.raymarine.com/manuals

LightHouse™ Sport operation instructions

For operation instructions for your product, please refer to the LightHouse™ Sport operation instructions.



The Basic (81384) and Advanced (81388) LightHouse™ Sport operation instructions can be downloaded from the Raymarine website: www.raymarine.com/manuals.

Please check the website to ensure you have the complete and most recent documentation for your product.

User manuals Print Shop

Raymarine provides a Print Shop service, enabling you to purchase a high-quality, professionally-printed manual for your Raymarine product.

Printed manuals are ideal for keeping onboard your vessel, as a useful source of reference whenever you need assistance with your Raymarine product.

Visit <http://www.raymarine.co.uk/view/?id=5175> to order a printed manual, delivered directly to your door.

For further information about the Print Shop, please visit the Print Shop FAQ pages:
<http://www.raymarine.co.uk/view/?id=5751>.

Note:

- Accepted methods of payment for printed manuals are credit cards and PayPal.
- Printed manuals can be shipped worldwide.
- Further manuals will be added to the Print Shop over the coming months for both new and legacy products.
- Raymarine user manuals are also available to download free-of-charge from the Raymarine website, in the popular PDF format. These PDF files can be viewed on a PC / laptop, tablet, smartphone, or on the latest generation of Raymarine multifunction displays.

Document illustrations

Your product and if applicable, its user interface may differ slightly from that shown in the illustrations in this document, depending on product variant and date of manufacture.

All images are provided for illustration purposes only.

2.2 Applicable products

This document applies to the following products:

Product part numbers

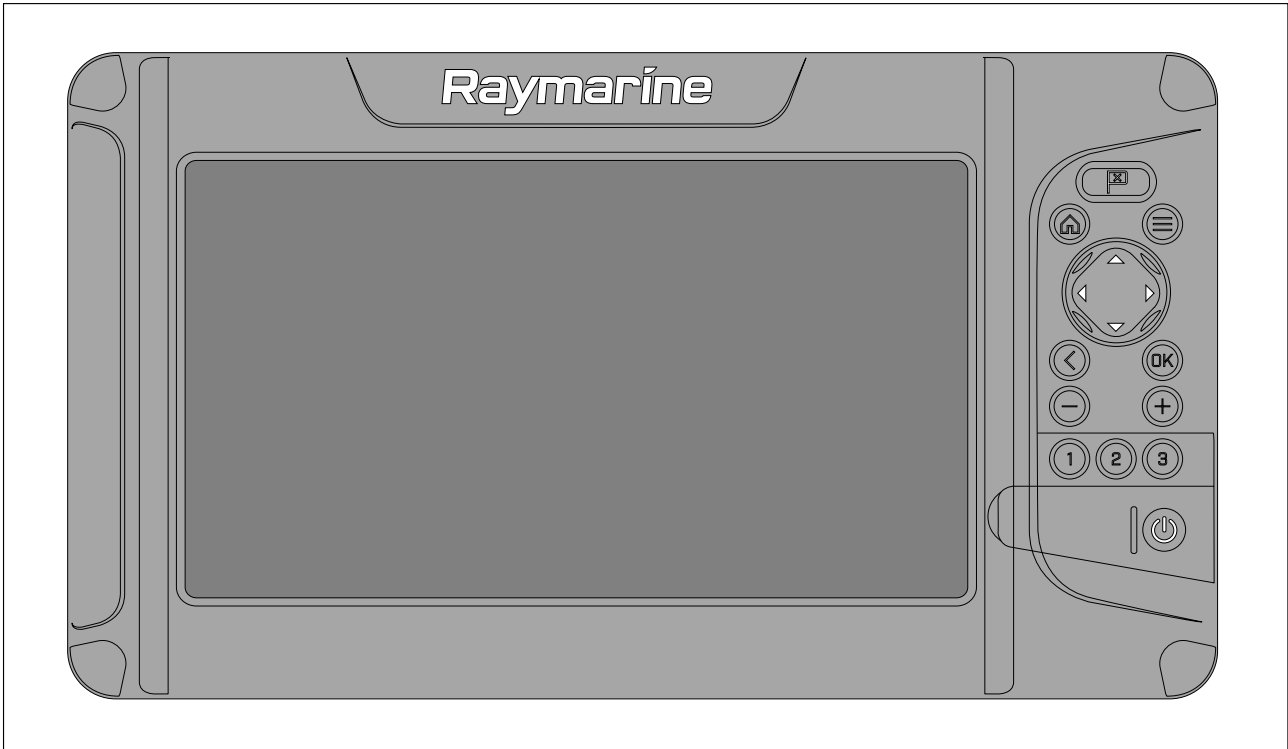

Part number	Description
E70532	Element™ 7 HV — HyperVision™ sonar / GPS combo with Wi-Fi.
E70531	Element™ 7 S — Conical sonar / GPS combo with Wi-Fi.
E70534	Element™ 9 HV — HyperVision™ sonar / GPS combo with Wi-Fi.
E70533	Element™ 9 S — Conical sonar / GPS combo with Wi-Fi.
E70536	Element™ 12 HV — HyperVision™ sonar GPS combo with Wi-Fi.
E70535	Element™ 12 S — Conical sonar GPS combo with Wi-Fi.

2.3 Product overview

Element™ displays are combination fishfinder / chartplotting displays that can be connected to a NMEA 2000 or SeaTalkng® network and display vessel data and data from compatible sensors and devices. Element displays are available with either a built-in HyperVision™ sonar module (Element™ HV), or a built-in conical sonar module (Element™ S).

Element™ displays include the following features:

- New simple-to-use LightHouse™ Sport operating system optimized for fishing.
- Sunlight-viewable LCD.
- Built in GPS / GNSS receiver.
- Supports wireless Quantum™ radar scanner connection.
- Send navigation data to connected autopilot.
- Supports AIS connection.
- Personal sonar mapping using Raymarine RealBathy™.
- Compatible with LightHouse NC2 charts with Fishing Hot Spots®, Navionics and C-MAP cartography.
- 3 user programmable Quicklaunch buttons.
- Share waypoints between networked Element™ displays.
- Supports display of data from up to 2 standard NMEA 2000–compliant trim tabs.
- Supports display of data from compatible networked (NMEA 2000 / SeaTalkng®) devices and sensors.
- Supports display of data from compatible engines when connected via an ECI-100.
- Transmit position data to a VHF radio connected to the same NMEA 2000 / SeaTalkng® backbone.

Element™ displays are available with and without built-in Wi-Fi. Displays that include Wi-Fi can connect to the internet and perform over the air software updates.

Element™ HV

Element™ HV display's HyperVision™ 1.2 MHz CHIRP sonar technology increases sonar image resolution, providing a higher level of precision for bottom structure, vegetation and fish identification.

When connected to a HyperVision™ transducer, the following fishfinder channels are available:

- RealVision™ 3D (Hyper 1.2 MHz)
- RealVision™ 3D (Standard 350 kHz)
- SideVision™ (Hyper 1.2 MHz)
- SideVision™ (Standard 350 kHz)
- DownVision™ (Hyper 1.2 MHz)
- DownVision™ (Standard 350 kHz)
- Sonar Conical high CHIRP (200 kHz)

Element™ S

When connected to a CPT-S transducer, only the traditional conical high CHIRP (200 kHz) fishfinder channel is available.

2.4 Compatible transducers - Element HV displays

HyperVision™ transducers

The following HyperVision™ transducers can be connected to Element™ HV displays:

Part number	Description
A80603	HV-100 — HyperVision™ Transom mount, Plastic transducer (direct connection).
A80604	HV-300TH — HyperVision™ All-in-one, Thru-hull, Plastic transducer (direct connection).
T70448	HV-300THP — HyperVision™ Pair, Thru-hull, Plastic transducers (direct connection using supplied cables).
R70725	HV-300THP-P Split, Port side, Thru-hull, Plastic transducer (Requires ‘Y’ cable (A80605) to connect split pair transducers, and extension cable (A80562) to connect to display).
R70726	HV-300THP-S Split, Starboard side, Thru-hull, Plastic transducer (Requires ‘Y’ cable (A80605) to connect split pair transducers, and extension cable (A80562) to connect to display).

Third party transducers

The third party transducers listed below can be connected to Element™ HV using adaptor cables.

Adaptor cable	Transducer
A80560	MinnKota Embedded, 83 kHz /200 kHz transducer.
A80606	MotorGuide Embedded, 83 kHz / 200 kHz transducer.

Note:
When using third party transducers only the 200 kHz channel will be available.

Compatible legacy transducers

DownVision™ transducers

The following DownVision™ transducers can be connected to Element™ HV displays using the CPT-S / DownVision 9–pin adaptor cable (A80559):

Part number	Description
A80507	CPT-90 DVS — DownVision™, Transom mount, Plastic transducer.
A80351	CPT-100 DVS — DownVision™, Transom mount, Plastic transducer. Replaced A80270.
A80277	CPT-110 — DownVision™, Thru-hull, Plastic transducer with fairing block.
A80350	CPT-120 — DownVision™, Thru-hull, Bronze transducer with fairing block. Replaced A80271.

Dragonfly® transducers

The following Dragonfly® transducers can be connected to Element™ HV displays using the Dragonfly 10–pin adaptor cable (A80558):

Part number	Description
R70374	CPT-DVS — DownVision™, Transom mount, Plastic transducer.
A80278	CPT-70 — DownVision™, Thru-hull, Plastic transducer with fairing block.
A80349	CPT-80 — DownVision™, Thru-hull, Bronze transducer with fairing block.

High CHIRP sonar transducers

The following conical beam, high CHIRP sonar transducers can be connected to Element™ HV displays using the CPT-S/DownVision 9-pin adaptor cable (A80559):

Part number	Description
E70342	CPT-S High CHIRP, Transom mount, Plastic transducer.
E70339	CPT-S High CHIRP, 0° angled element, Flush mount, Thru-hull, Plastic transducer.
A80448	CPT-S High CHIRP, 12° angled element, Flush mount, Thru-hull, Plastic transducer.
A80447	CPT-S High CHIRP, 20° angled element, Flush mount, Thru-hull, Plastic transducer.
A80446	CPT-S High CHIRP, 0° angled element, Flush mount, Thru-hull, Bronze transducer.
E70340	CPT-S High CHIRP, 12° angled element, Flush mount, Thru-hull, Bronze transducer.
E70341	CPT-S High CHIRP, 20° angled element, Flush mount, Thru-hull, Bronze transducer.

Legacy transducer extension cables

When connecting a compatible legacy transducer to an Element display, using an adaptor cable: if the cable run requires extending, you must use an extension cable which is compatible with your transducer.

Important: The HyperVision™ extension cable cannot be used to extend the cable run of legacy transducers.	
Legacy transducer	Compatible extension cable
Dragonfly® transducers	A80312 — 4 m (13.1 ft) Dragonfly® transducer extension cable. Note: Power supply wires should be isolated and protected from shorting or water ingress.
DownVision™ transducers	E66074 — 3 m (9.84 ft) DownVision™ transducer extension cable.
High CHIRP sonar transducers	A80273 — 4 m (13.1 ft) CPT-S transducer extension cable.

2.5 Compatible transducers - Element S displays

High CHIRP sonar transducers

The following conical beam, high CHIRP sonar transducers can be connected to Element™ S displays:

Part number	Description
E70342	CPT-S High CHIRP, Transom mount, Plastic transducer.
E70339	CPT-S High CHIRP, 0° angled element, Flush mount, Thru-hull, Plastic transducer.
A80448	CPT-S High CHIRP, 12° angled element, Flush mount, Thru-hull, Plastic transducer.
A80447	CPT-S High CHIRP, 20° angled element, Flush mount, Thru-hull, Plastic transducer.
A80446	CPT-S High CHIRP, 0° angled element, Flush mount, Thru-hull, Bronze transducer.
E70340	CPT-S High CHIRP, 12° angled element, Flush mount, Thru-hull, Bronze transducer.
E70341	CPT-S High CHIRP, 20° angled element, Flush mount, Thru-hull, Bronze transducer.

2.6 Optional additional components

The following optional products and devices can be used with or connected to your display.

- **MicroSD memory / electronic cartography card** — Inserting a compatible memory card into the card reader enables:
 - display of compatible electronic cartography.
 - collection and display of Realbathy™ personal sonar data.
 - Back up and restore of user data and settings.
 - saving screenshot image files.
- **EV-1 Heading sensor** (E70096) — Connecting the display to a NMEA 2000 / SeaTalkng® backbone that includes an EV-1 enables vessel heading data to be available, regardless of vessel movement.
- **Quantum™ radar scanner** (E70344, E70210 and E70498) — Connecting the display to a compatible radar scanner using Wi-Fi enables use of the Radar app.
- **Evolution™ autopilot system** — Connecting the display to the same network as an Evolution autopilot system enables navigation data to be sent to a compatible autopilot controller.
- **ECI-100** (E70227) — Connecting the display to a NMEA 2000 / SeaTalkng® backbone that includes an ECI-100 enables display of compatible engine data. For further information on compatible engines refer to: [p.21 — Compatible engine systems](#)
- **Third-party tank level sensors** — Connecting the display to a NMEA 2000 or SeaTalkng® backbone that includes standard third-party NMEA 2000 tank level sensors enables the display of tank level sensor data . For further details on tank level sensors refer to: [p.22 — Compatible tank level sensors](#)
- **VHF radio** — Connecting the display to a NMEA 2000 or SeaTalkng® backbone can provide position data to a compatible VHF radio.
- **RS150 GNSS receiver** (E70310) — Connecting an external GNSS / GPS receiver can provide more accurate position tracking.
- **AIS700 / AIS650 / AIS350** (E70476 / E32158 / E32157) — Connecting compatible AIS hardware allows AIS targets to be tracked in the chart app.
- **iTC-5** (E70010) — Connecting the display to a NMEA 2000 / SeaTalkng® backbone that includes analog transducers connected via an iTC-5 enables the display of transducer sensor data (depth, speed, wind, water temperature etc.) in databoxes and the dashboard app. Refer to the iTC-5 installation instructions (87138) for further information on connecting analog transducers via an iTC-5.

Note: Transducer calibration is not supported by the display and must be performed on an appropriate SeaTalkng® instrument display such as the i70S multifunction instrument display.

- **Airmar NMEA 2000 smart sensors** — Connecting an Airmar smart sensor such as a DST800 or P79.

Data compatibility

In addition to products listed as compatible in this document, your product can also receive and display data from other NMEA 2000 devices.

For data to be displayed onscreen the display must receive data from NMEA 2000 devices using supported NMEA 200 PGN messages.

A list of NMEA 2000 PGN messages that are supported by your display can be found in the appendix of this document: [p.87 — SeaTalkng® cables and accessories](#)

Compatible engine systems

When connected to an NMEA 2000 / SeaTalkng® backbone via an ECI-100 engine gateway (E70227), engine data for up to two compatible engines can be displayed. The following engine systems are supported.

- Volvo Penta Electronic Vessel Control (EVC) systems
- Yamaha Marine Command Link
- Yamaha Marine Command Link Plus
- Yanmar engine systems

- Honda engines
- Caterpillar engine systems (must include MPD, MPD color or mini MPD)
- Other engine systems which use standard NMEA 2000 protocols.

Note:

For more information on connecting the ECI-100 to engine systems, including a list of supported NMEA 2000 messages, refer to the *ECI-100 Installation instructions (87202)*.

Compatible tank level sensors

When connected to an NMEA 2000 / SeaTalkng[®] backbone, tank level sensor data can be displayed. The majority of NMEA 2000-compliant tank level sensors are supported. If in doubt as to whether your level sensor is compatible, contact Raymarine product support.

Data can be displayed for:

- Up to 2 x fuel level tank sensors
- Up to 2 x fresh water level tank sensors
- Up to 2 x live well level tank sensors
- 1 x Gray water level tank sensor
- 1 x Black water level tank sensor

Note: A list of NMEA 2000 PGNs that are supported by the display is provided in the appendix:
[p.89 – NMEA 2000 PGNs](#)

2.7 Parts supplied

The following parts are supplied in the box.

Unpack your product carefully to prevent damage or loss of parts. Check the box contents against the list below. Retain the packaging and documentation for future reference.

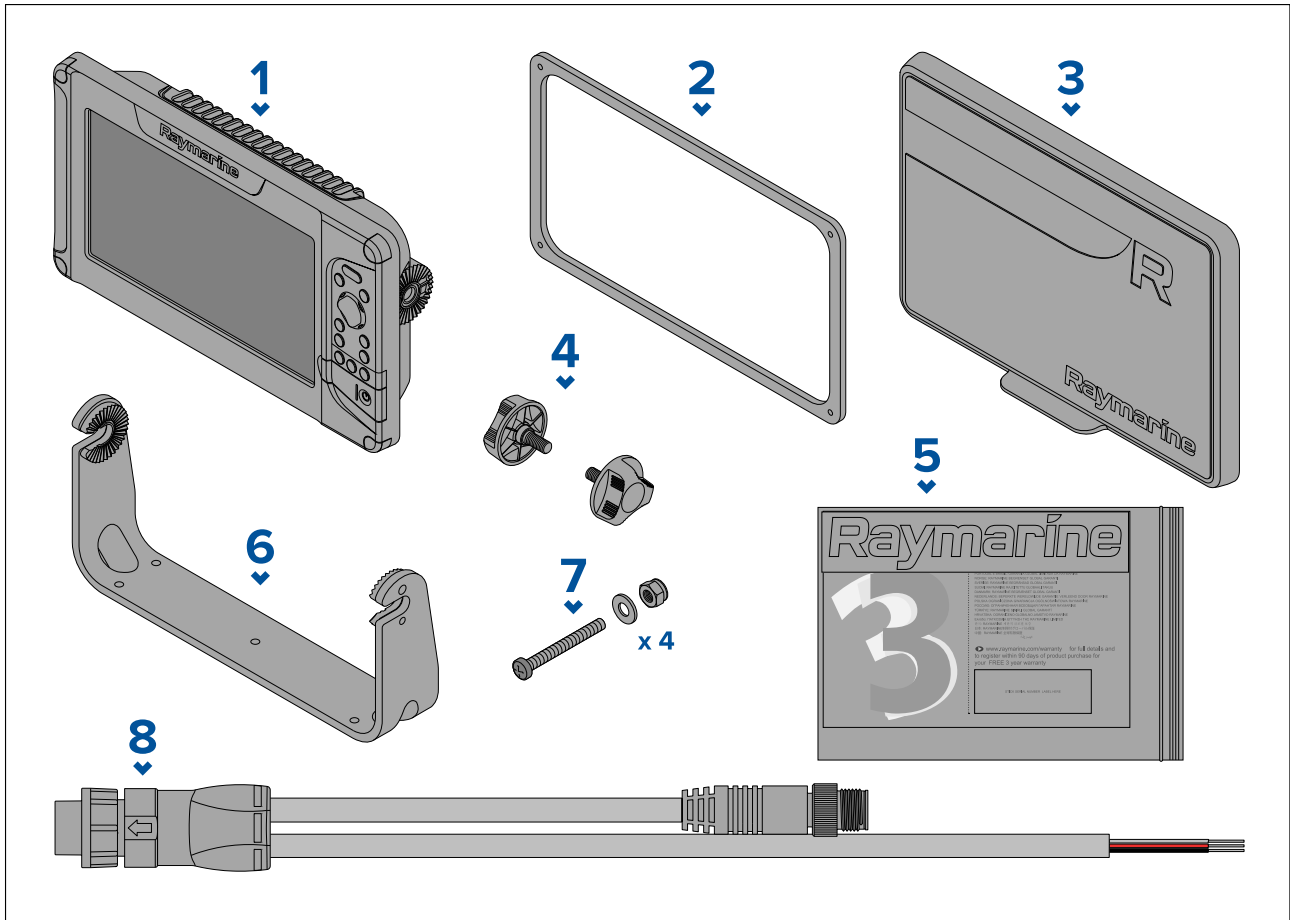

1. Element™ display.
2. Surface mount gasket.
3. Suncover.
4. Trunnion knobs x 2.
5. Documentation pack
6. Trunnion bracket
7. Surface mount stainless steel fixings x 4 (M4 x 40 machine screw, M4 flat washer, M4 locking nut)
8. Power / NMEA 2000 cable (includes 1.5 m (4.92 ft) power lead and 0.5 m (1.64 ft) NMEA 2000 lead).

Chapter 3: Installation

Chapter contents

- [3.1 Selecting a location on page 26](#)
- [3.2 Product dimensions on page 29](#)
- [3.3 Mounting options on page 30](#)
- [3.4 Trunnion bracket mounting on page 31](#)
- [3.5 Surface mounting on page 32](#)

3.1 Selecting a location



Warning: Switch off power supply

Ensure the vessel's power supply is switched OFF before starting to install this product. Do NOT connect or disconnect equipment with the power switched on, unless instructed in this document.



Warning: Potential ignition source

This product is NOT approved for use in hazardous/flammable atmospheres. Do NOT install in a hazardous/flammable atmosphere (such as in an engine room or near fuel tanks).

General location requirements

When selecting a location for the unit it is important to consider a number of factors.

To ensure optimum performance, it is recommended that the display is temporarily powered up and tested, at the chosen location, prior to installation.

Ventilation requirements

To provide adequate airflow around the product ensure that it is adequately separated from other equipment or sources of heat.

Mounting surface requirements

When selecting a mounting surface ensure:

- the product will be adequately supported on a secure, flat surface. Do NOT mount units or cut holes in places which may damage the structure of the vessel.
- sufficient space is available around the product.
- there is nothing behind the mounting surface that may be damaged when drilling.

Cable routing requirements

Ensure you have identified the route that all required cables will take and that sufficient space is available to allow connection of cables:

- Unless otherwise stated, a minimum cable bend radius of 100 mm (3.94 in) is required.
- Where necessary, cable supports should be used to prevent stress on connectors.

Electrical interference

Select a location that is far enough away from equipment that may cause interference, such as motors, generators and radio transmitters/receivers.

Compass safe distance

To prevent potential interference with the vessel's magnetic compasses, ensure an adequate distance is maintained from the product.

When choosing a suitable location for the product you should aim to maintain the maximum possible distance from any compasses. Typically this distance should be at least 1 m (3.3 ft) in all directions. However for some smaller vessels it may not be possible to locate the product this far away from a compass. In this situation, when choosing the installation location for your product, ensure that the compass is not affected by the product when it is in a powered state.

Viewing angle considerations

Display contrast and color are effected by the angle the display is viewed from., If you intend to surface mount the display, it is recommended that you temporarily power up the display at the desired location before installation.

GPS/GNSS location requirements

Your product includes a built in GPS/GNSS antenna. Ensure you consider the following before choosing a location for you product:

Mounting location

It is recommended that the product is installed above decks as this will provide optimal GPS/GNSS performance. Below decks installation may impact GPS/GNSS performance.

Vessel construction

The construction of your vessel can have an impact on GPS/GNSS performance. For example, the proximity of heavy structures such as bulkheads, may result in a reduced GPS/GNSS signal.

Prevailing conditions

Weather conditions and the geographic location of the vessel can effect GPS/GNSS performance. Typically calm clear conditions provide a more accurate position fix. Vessels at extreme northerly or southerly latitudes may also receive a weaker GPS/GNSS signal. Product mounted below decks will be more susceptible to performance issues related to the prevailing conditions.

Wireless location requirements

A number of factors can influence wireless performance. It is important to ensure you test the connection performance at the desired location before installing wireless-enabled products.

Distance

The distance between wireless products should always be kept to a minimum. Do not exceed the maximum stated range of your wireless product (maximum range will vary for each device).

Wireless performance degrades over distance, so products farther away will receive less network bandwidth. Products installed close to their maximum wireless range may experience slow connection speeds, signal dropouts, or not being able to connect at all.

Line of sight

For best results the wireless product should have a clear, direct line of sight to the product it will be connected to. Any physical obstructions can degrade or even block the wireless signal.

The construction of your vessel can also have an impact on wireless performance. For example, metal structural bulkheads and roofing will reduce — and in certain situations — block the wireless signal.

If the wireless signal passes through a bulkhead containing power cables this can also degrade wireless performance.

Reflective surfaces such as metal surfaces, some types of glass and even mirrors can drastically affect performance or even block the wireless signal.

Interference and other equipment

Wireless products should be installed at least 1m (3 ft) away from:

- Other wireless-enabled products.
- Transmitting products that send wireless signals in the same frequency range.
- Other electrical, electronic or electromagnetic equipment that may generate interference.

Interference from other people's wireless devices can also cause interference with your products. You can use a third-party wireless analyzer tool / smartphone app to assess the best wireless channel to use (e.g. a channel not in use or one used by the least number of devices).

EMC installation guidelines

Raymarine equipment and accessories conform to the appropriate Electromagnetic Compatibility (EMC) regulations, to minimize electromagnetic interference between equipment and minimize the effect such interference could have on the performance of your system

Correct installation is required to ensure that EMC performance is not compromised.

Note: In areas of extreme EMC interference, some slight interference may be noticed on the product. Where this occurs the product and the source of the interference should be separated by a greater distance.

For **optimum** EMC performance we recommend that wherever possible:

- Raymarine equipment and cables connected to it are:
 - At least 1 m (3.3 ft) from any equipment transmitting or cables carrying radio signals e.g. VHF radios, cables and antennas. In the case of SSB radios, the distance should be increased to 2 m (6.6 ft).
 - More than 2 m (6.6 ft) from the path of a radar beam. A radar beam can normally be assumed to spread 20 degrees above and below the radiating element.
- The product is supplied from a separate battery from that used for engine start. This is important to prevent erratic behavior and data loss which can occur if the engine start does not have a separate battery.
- Raymarine specified cables are used.
- Cables are not cut or extended, unless doing so is detailed in the installation manual.

Note:

Where constraints on the installation prevent any of the above recommendations, always ensure the maximum possible separation between different items of electrical equipment, to provide the best conditions for EMC performance throughout the installation.

RF interference

Certain third-party external electrical equipment can cause Radio Frequency (RF) interference with GNSS (GPS), AIS or VHF devices, if the external equipment is not adequately insulated and emits excessive levels of electromagnetic interference (EMI).

Some common examples of such external equipment include LED lighting (e.g.: navigation lights, searchlights and floodlights, interior and exterior lights) and terrestrial TV tuners.

To minimize interference from such equipment:

- Keep it as far away from GNSS (GPS), AIS or VHF products and their antennas as possible.
- Ensure that any power cables for external equipment are not entangled with the power or data cables for these devices.
- Consider fitting one or more high frequency suppression ferrites to the EMI-emitting device. The ferrite(s) should be rated to be effective in the range 100 MHz to 2.5 GHz, and should be fitted to the power cable and any other cables exiting the EMI-emitting device, as close as possible to the position where the cable exits the device.

3.2 Product dimensions

Trunnion mount dimensions

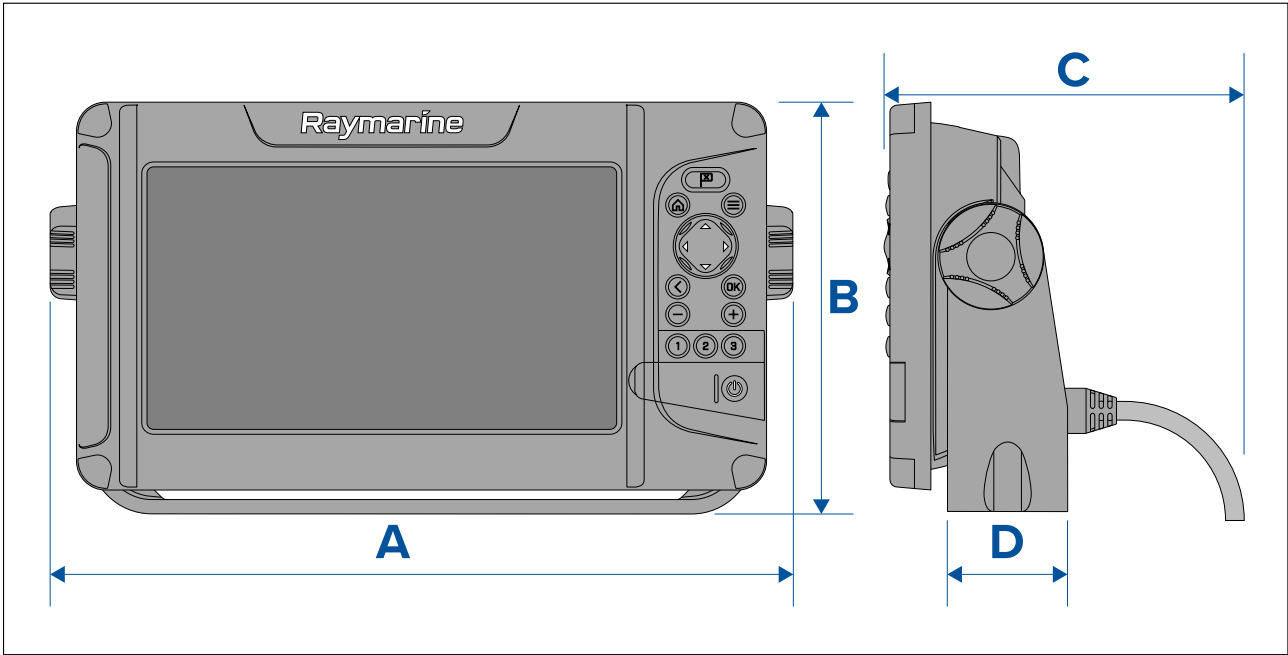

	Element 7	Element 9	Element 12
A	263.85 mm (10.39 in)	308.40 mm (12.14 in)	373.40 mm (14.70 in)
B	162.59 mm (6.40 in)	171.00 mm (6.73 in)	225.19 mm (8.87 in)
C	149.40 mm (5.88 in)		
D	60.84 mm (2.40 in)	50.11 mm (1.97 in)	55.00 mm (2.17 in)

Surface mount dimensions

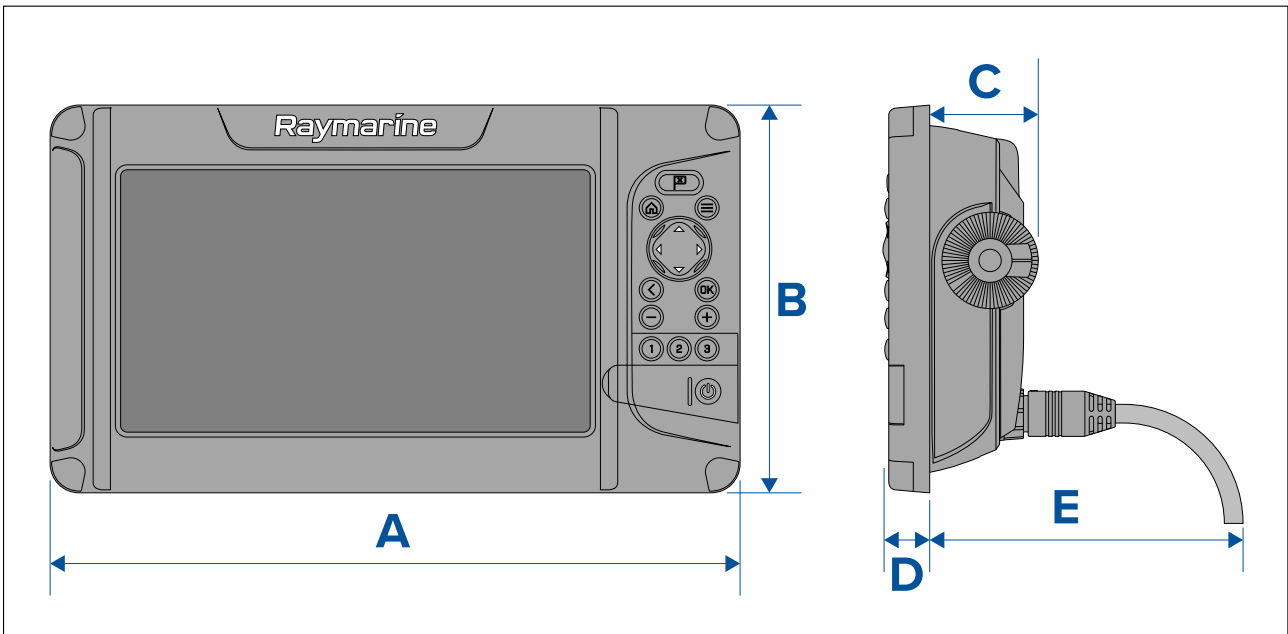

	Element 7	Element 9	Element 12
A	239.60 mm (9.43 in)	286.50 mm (11.28 in)	357.20 mm (14.06 in)
B	135.10 mm (5.32 in)	161.00 mm (6.34 in)	215.20 mm (8.47 in)
C	45.00 mm (1.77 in)		46.00 mm (1.81 in)
D	19.40 mm (0.76 in)		
E	130.00 mm (5.12 in)		

3.3 Mounting options

Element displays can be either trunnion mounted or surface mounted.

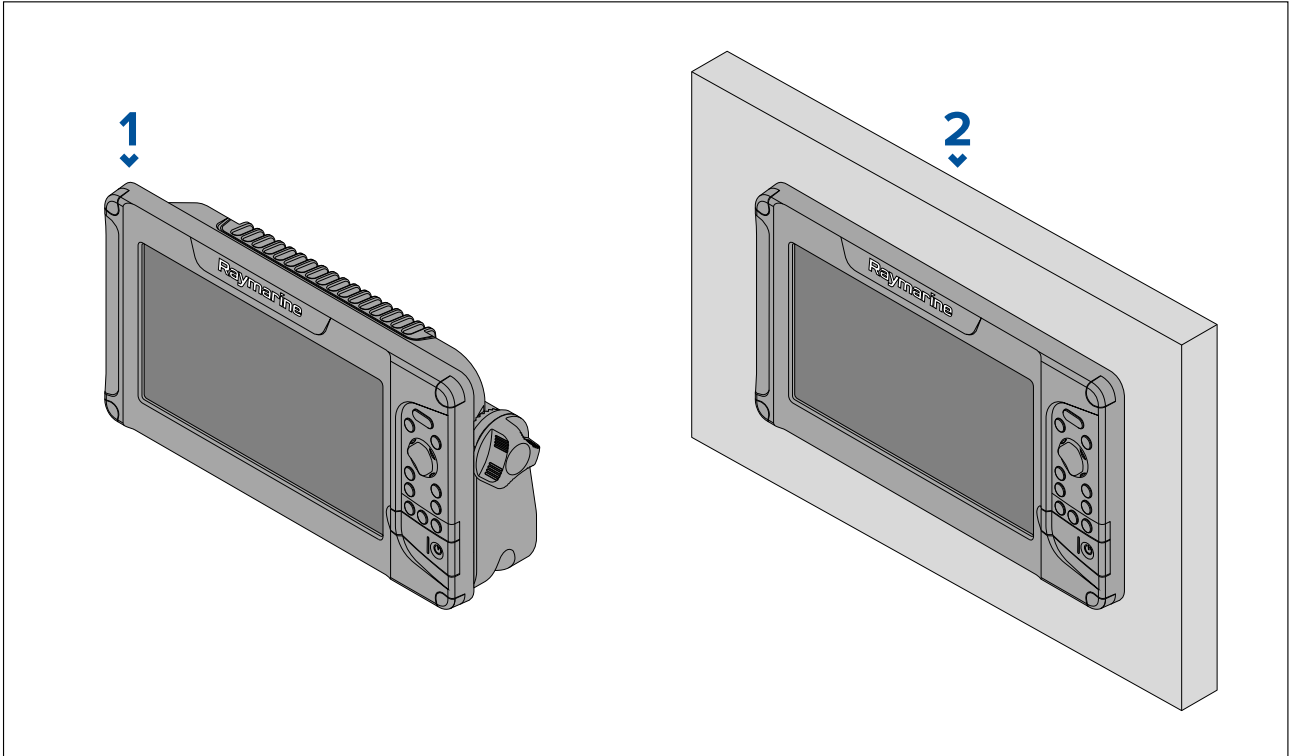

1. Trunnion mounted.
2. Surface mounted.

3.4 Trunnion bracket mounting

The supplied trunnion bracket can be used to mount your display on a horizontal surface.

Ensure you have chosen a suitable mounting location for your display, with sufficient headroom to allow the display's angle to be adjusted or the display to be removed if necessary. If installing 'above head', take extra care to ensure the knobs are tightened sufficiently to prevent them coming undone due to vibration when underway.

Important:

Before mounting the display, ensure you have sourced suitable fixings for mounting the display's trunnion bracket to the desired mounting surface. Fixing type will be determined by the mounting location, and the material type and thickness of the mounting surface.

- Element™ 7: Requires 4 x fixings. The Trunnion bracket's mounting hole diameter is 4.2 mm (0.17 in).
- Element™ 9 and Element™ 12: Require 5 x fixings. The Trunnion bracket's mounting hole diameter is 5.75 mm (0.23 in).

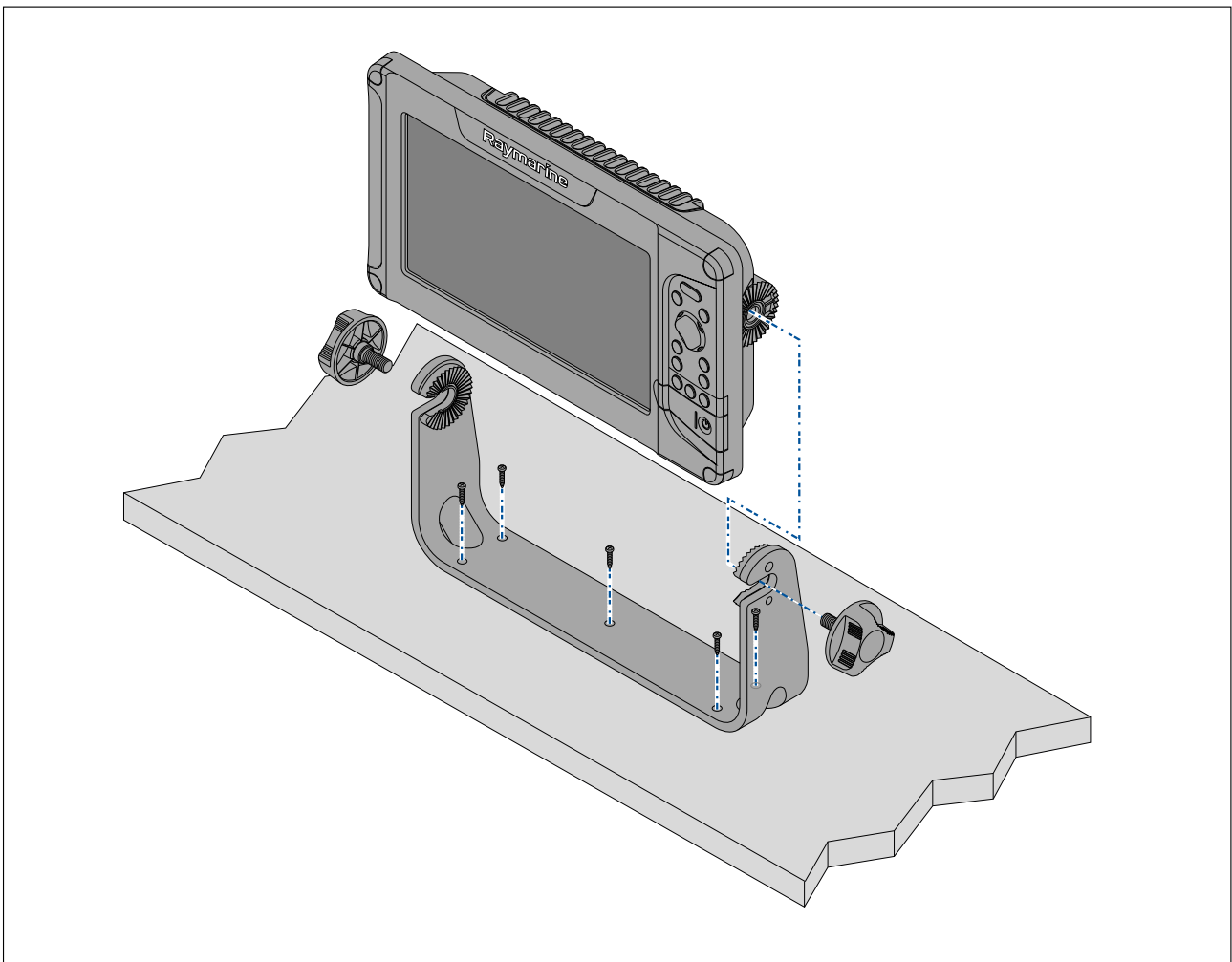

1. Using the Bracket as a template, mark and drill pilot holes in the mounting surface.
2. Using appropriate fixings (not supplied), secure the trunnion bracket to the mounting surface.

If the mounting surface is too thin for the screws provided, use stainless steel machine screws, washers and locking nuts. Alternatively, reinforce the rear of the mounting surface.

3. Using the bracket knobs, secure the display to the Bracket, ensuring the ratchet teeth are correctly engaged.

The knobs should be tightened by hand, sufficiently to prevent the display from moving whilst your vessel is underway.

4. Route and connect necessary cables.

3.5 Surface mounting

The supplied mounting gasket and fixings can be used to surface mount the display.

Before mounting the display, ensure that you have:

- chosen a suitable location, using the guidance provided;
- identified the required cable connections and routed the cables to the mounting location.

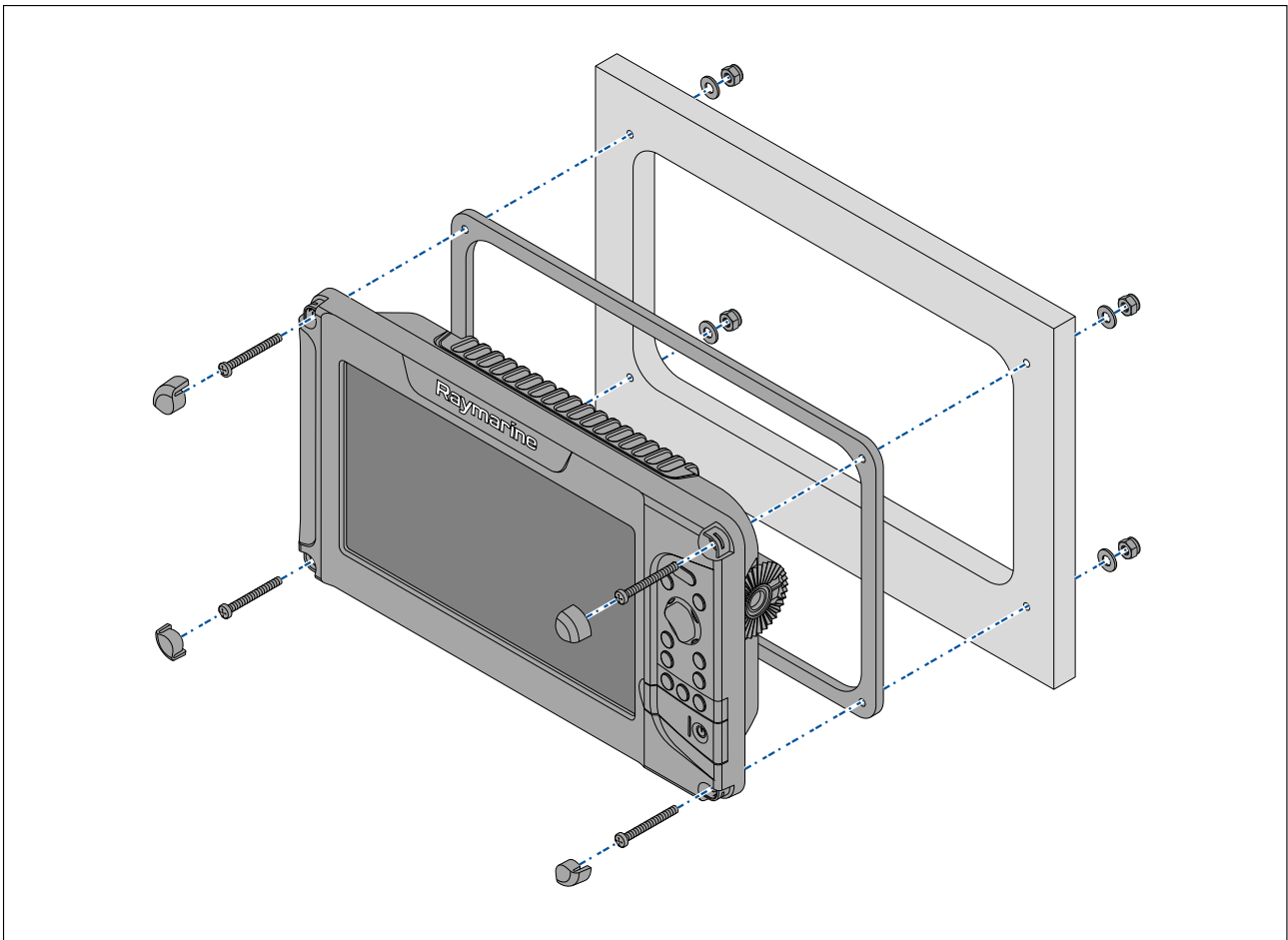

1. Remove the 4 screw covers from the corners of the display.

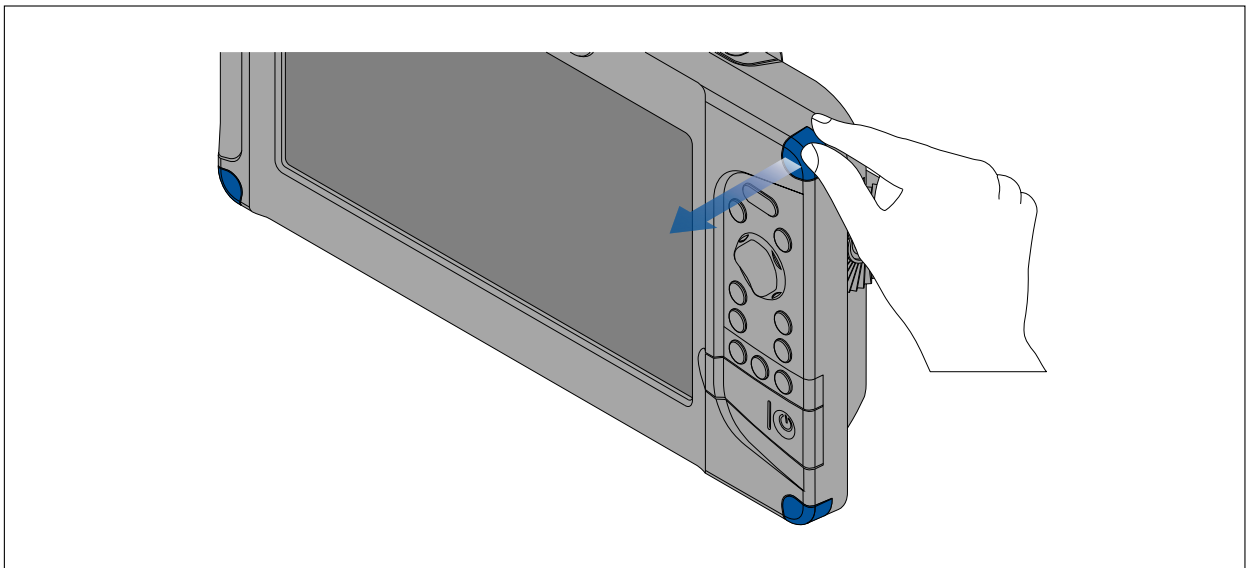

2. Check the chosen mounting location. A clear, flat area with suitable clearance behind the panel is required.
3. Fix the supplied mounting template to the chosen location using masking or self-adhesive tape.
4. Using a suitable hole saw (the size is indicated on the template), make a hole in each corner of the cut-out area.
5. Using a suitable saw, cut along the inside edge of the cut-out line.

6. Ensure that the unit fits into the removed area and then file around any rough edges until smooth.
7. Drill 4 holes as indicated on the template to accept the fixings.
8. Place the gasket onto the rear of the display and press firmly onto the flange.
9. Connect the power, data and other cables.
10. Slide the unit into place and secure using the fixings provided.
11. Refit the screw covers.

Note:

The supplied gasket provides a seal between the unit and a suitably flat and stiff mounting surface or binnacle. If the mounting surface or binnacle is not entirely flat and stiff or has a rough surface finish, in addition to using the mounting gasket it may also be necessary to use marine-grade sealant.

Chapter 4: Connections

Chapter contents

- [4.1 Connections Overview on page 36](#)
- [4.2 General cabling guidance on page 38](#)
- [4.3 Power connection on page 39](#)
- [4.4 Element™ HV transducer connection on page 44](#)
- [4.5 Element™ HV legacy transducer connection on page 47](#)
- [4.6 Element™ S transducer connection on page 48](#)
- [4.7 SeaTalkng® connection on page 49](#)
- [4.8 SeaTalkng® system example on page 50](#)
- [4.9 Pairing a Quantum™ radar scanner on page 52](#)
- [4.10 Element autopilot connection on page 53](#)

4.1 Connections Overview

The connectors are provided on the rear of the display.

Physical connections

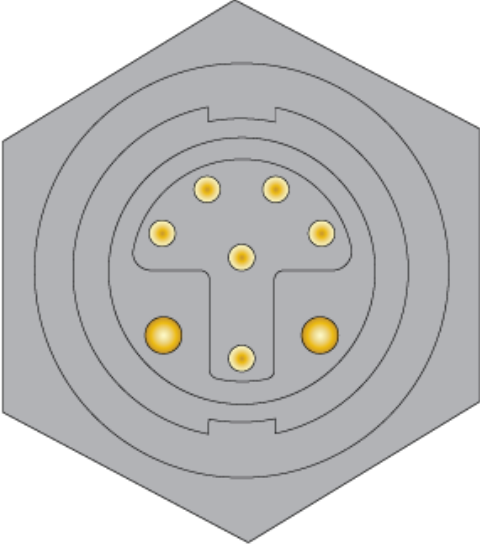
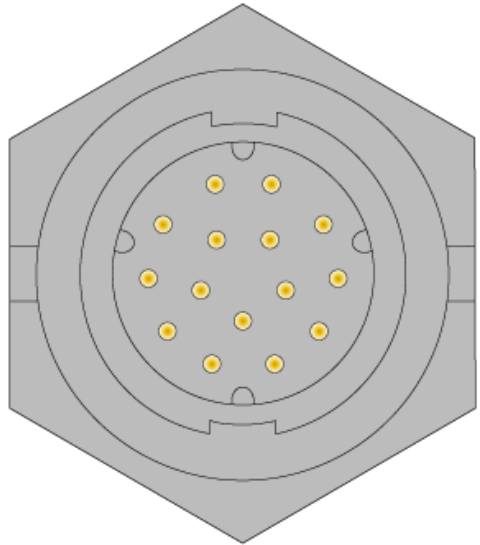
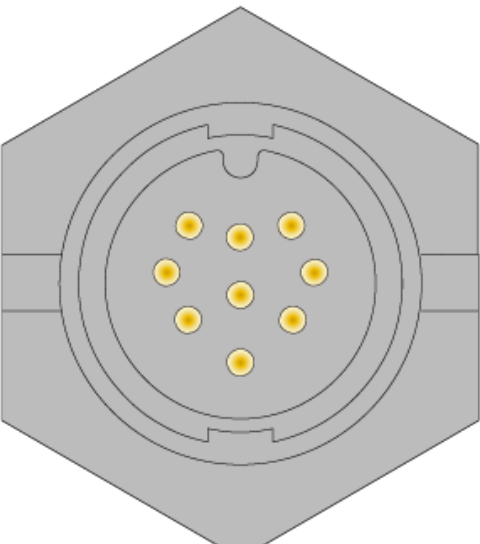
Connector	Connection
	<p>Power and NMEA 2000 8-pin connector. Use the supplied power and data cable to connect to:</p> <ul style="list-style-type: none"> • 12 V DC power supply. Refer to: p.39 – Power connection • NMEA 2000 or SeaTalkng[®] backbone. Refer to: p.49 – SeaTalkng[®] connection
	<p>HyperVision™ transducer 15-pin connector — available on Element™ HV variant displays. HyperVision transducer's cable or a compatible transducer extension cable. Refer to: p.44 – Element™ HV transducer connection</p>
	<p>CPT-S transducer 9-pin connector — available on Element™ S variant displays. CPT-S transducer's cable or a compatible transducer extension cable. Refer to: p.48 – Element™ S transducer connection</p>

Wireless connections

Connector	Connection
 The image shows the standard Wi-Fi symbol, which consists of four curved lines of increasing size radiating from a small semi-circle at the bottom, representing signal strength.	<p>Wi-Fi connection. Use Wi-Fi to a Quantum™ radar scanner.</p>

4.2 General cabling guidance

Cable types and length

It is important to use cables of the appropriate type and length.

- Unless otherwise stated only use cables supplied by Raymarine.
- Where it is necessary to use non-Raymarine cables, ensure that they are of correct quality and gauge for their intended purpose. (e.g.: longer power cable runs may require larger wire gauges to minimize voltage drop along the run).

Strain relief

Use adequate strain relief for cabling to ensure that connectors are protected from strain and will not pull out under extreme sea conditions.

Cable shielding

Ensure that cable shielding is not damaged during installation and that all cables are properly shielded.

Making connections

Follow the steps below to connect the cable(s) to your product.

1. Ensure that the vessel's power supply is switched off.
2. Ensure that the device being connected to the unit has been installed in accordance with the installation instructions supplied with that device.
3. Ensuring correct orientation, push the cable connector fully onto the corresponding connector on the unit.
4. Turn the locking collar clockwise to secure the cable.

4.3 Power connection

The power cable must be connected to a 12 V dc power supply, this can be achieved by connecting directly to a battery, or via the distribution panel. The product is protected against reverse polarity.

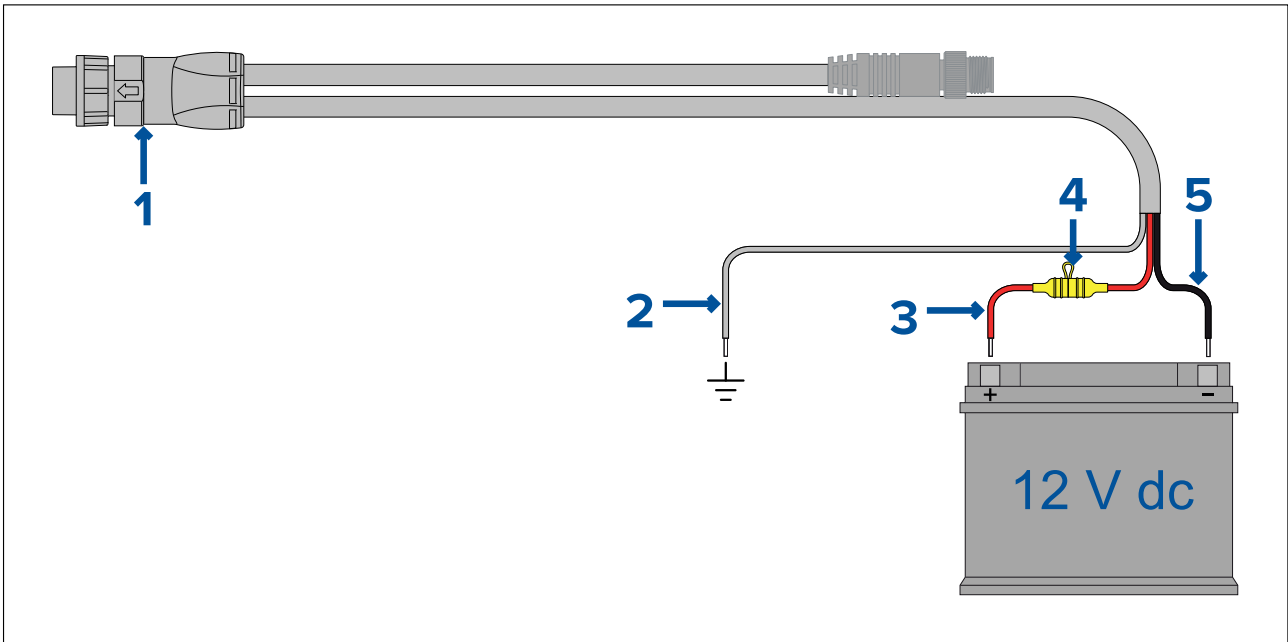

1. Power/NMEA 2000 cable connects to the rear of the display.
2. Ground wire connects to RF ground point, if no ground point is available connect to the battery negative (-) terminal.
3. Positive (Red) wire connects to battery positive (+) terminal.
4. Waterproof fuse holder with 5 A inline fuse must be fitted (not supplied).
5. Negative wire connects to battery negative (-) terminal.

Important:

To prevent erratic behavior and potential data loss, ensure the product is supplied from a separate battery from that used for engine start.

In-line fuse and thermal breaker ratings

The following in-line fuse and thermal breaker ratings apply to your product:

In-line fuse rating	Thermal breaker rating
5 A	3 A

Note:

- The suitable fuse rating for the thermal breaker is dependent on the number of devices you are connecting. If in doubt consult an authorized Raymarine dealer.
- Your product's power cable may have an in-line fuse fitted, if not then you must add an in-line fuse / breaker to the positive wire of your product's power connection.

Caution: Power supply protection

When installing this product ensure the power source is adequately protected by means of a suitably-rated fuse or automatic circuit breaker.

Grounding — Dedicated drain wire

The power cable supplied with this product includes a dedicated shield (drain) wire for connection to a vessel's RF ground point.

It is important that an effective RF ground is connected to the system. A single ground point should be used for all equipment. The unit can be grounded by connecting the shield (drain) wire of the power cable to the vessel's RF ground point. On vessels without an RF ground system the shield (drain) wire should be connected directly to the negative battery terminal.

The dc power system should be either:

- Negative grounded, with the negative battery terminal connected to the vessel's ground.
- Floating, with neither battery terminal connected to the vessel's ground

Power distribution

Recommendations and best practice.

- The product is supplied with a power cable, either as a separate item or a captive cable permanently attached to the product. Only use the power cable supplied with the product. Do NOT use a power cable designed for, or supplied with, a different product.
- Refer to the *Power connection* section for more information on how to identify the wires in your product's power cable, and where to connect them.
- See below for more information on implementation for some common power distribution scenarios:

Important:

- When planning and wiring, take into consideration other products in your system, some of which (e.g. sonar modules) may place large power demand peaks on the vessel's electrical system, which may impact the voltage available to other products during the peaks.
- The information provided below is for guidance only, to help protect your product. It covers common vessel power arrangements, but does NOT cover every scenario. If you are unsure how to provide the correct level of protection, please consult an authorized Raymarine dealer or a suitably qualified professional marine electrician.

Implementation — connection to distribution panel (Recommended)

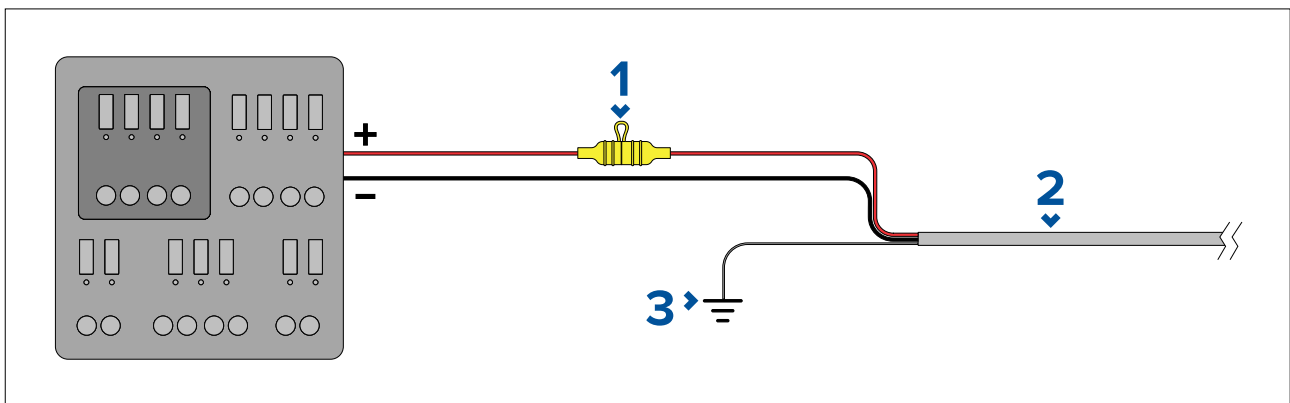

1	Waterproof fuse holder containing a suitably-rated inline fuse must be fitted. For suitable fuse rating, refer to: <i>In-line fuse and thermal breaker ratings</i> .
2	Product power cable.
3	Drain wire connection point.

- It is recommended that the supplied power cable is connected to a suitable breaker or switch on the vessel's distribution panel or factory-fitted power distribution point.
- The distribution point should be fed from the vessel's primary power source by 8 AWG (8.36 mm²) cable.
- Ideally, all equipment should be wired to individual suitably-rated thermal breakers or fuses, with appropriate circuit protection. Where this is not possible and more than 1 item of equipment shares a breaker, use individual in-line fuses for each power circuit to provide the necessary protection.

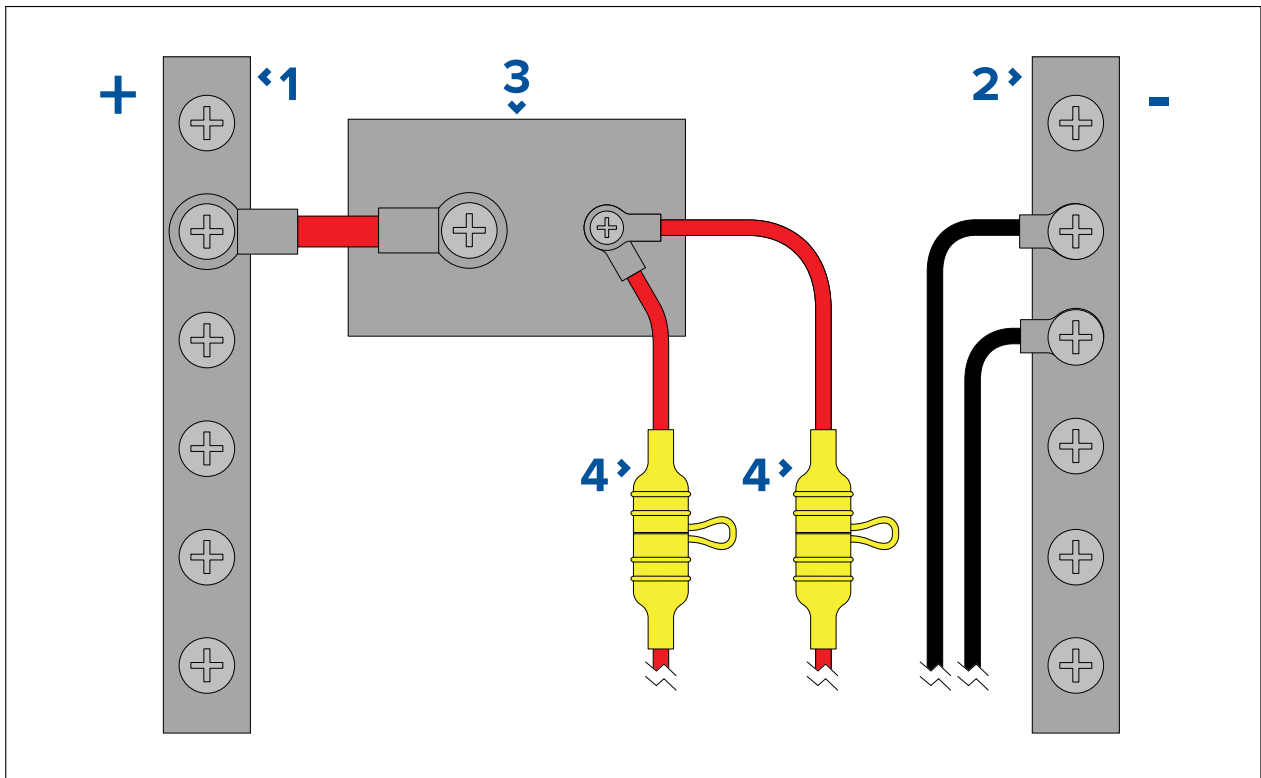

1	Positive (+) bar
2	Negative (-) bar
3	Circuit breaker
4	Waterproof fuse holder containing a suitably-rated inline fuse must be fitted. For suitable fuse rating, refer to: <i>In-line fuse and thermal breaker ratings.</i>

Important:
 Observe the recommended fuse / breaker ratings provided in the product's documentation, however be aware that the suitable fuse / breaker rating is dependent on the number of devices being connected.

Implementation – direct connection to battery

- Where connection to a power distribution panel is not possible, the power cable supplied with your product may be connected directly to the vessel's battery, via a suitably rated fuse or breaker.
- The power cable supplied with your product may NOT include a separate drain wire. If this is the case, only the power cable's red and black wires need to be connected.
- If the power cable is NOT supplied with a fitted inline fuse, you MUST fit a suitably rated fuse or breaker between the red wire and the battery's positive terminal.
- Refer to the inline fuse ratings provided in the product's documentation.
- If you need to extend the length of the power cable supplied with your product, ensure you observe the dedicated *Power cable extensions* advice provided in the product's documentation.

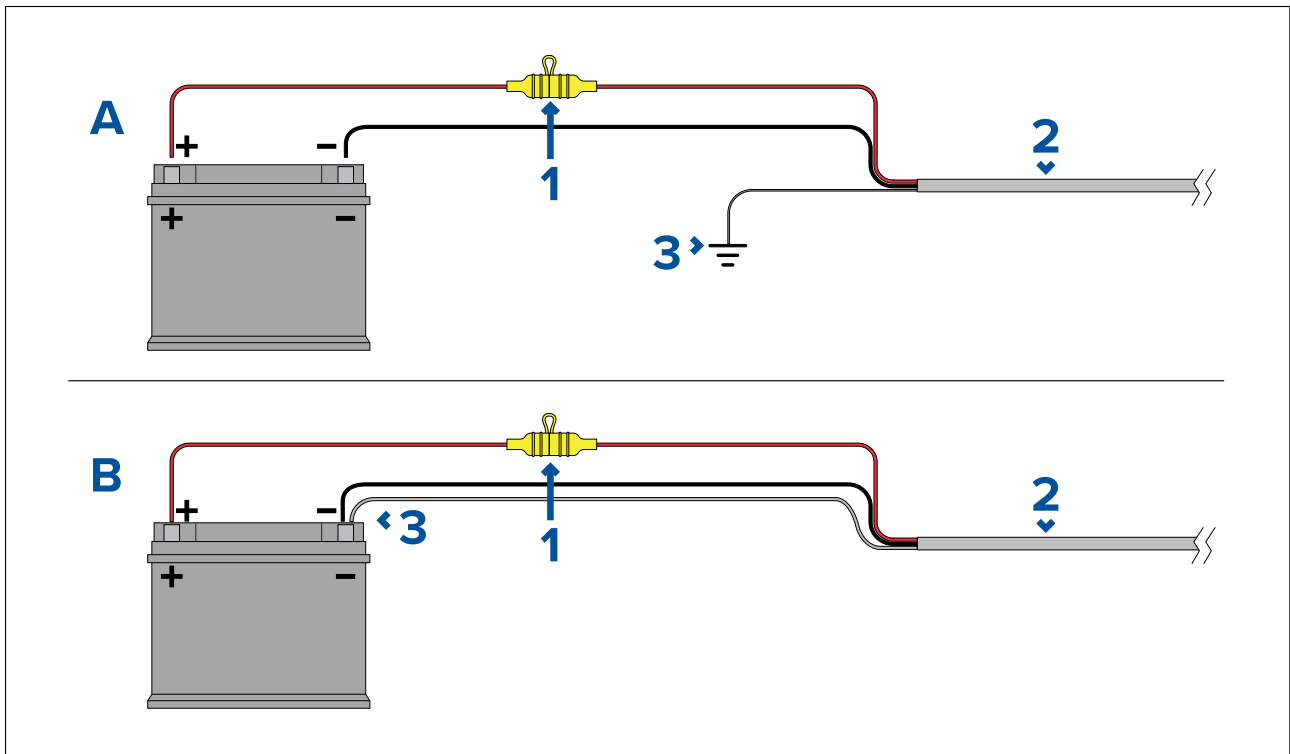

1	Waterproof fuse holder containing a suitably-rated inline fuse must be fitted. For suitable fuse rating, refer to: <i>In-line fuse and thermal breaker ratings</i> .
2	Product power cable.
3	Drain wire connection point.

Battery connection scenario A:

Suitable for a vessel with a common RF ground point. In this scenario, if your product's power cable is supplied with a separate drain wire then it should be connected to the vessel's common ground point.

Battery connection scenario B:

Suitable for a vessel without a common grounding point. In this case, if your product's power cable is supplied with a separate drain wire then it should be connected directly to the battery's negative terminal.

Power cable extension

If you need to extend the length of the power cable supplied with your product, ensure you observe the following advice:

- The power cable for each unit in your system should be run as a separate, single length of 2-wire cable from the unit to the vessel's battery or distribution panel.
- For power cable extensions, a **minimum** wire gauge of 16 AWG (1.31 mm²) is recommended. For cable runs longer than 15 meters, you may need to consider a thicker wire gauge (e.g. 14 AWG (2.08 mm²), or 12 AWG (3.31 mm²)).
- An important requirement for all lengths of power cable (including any extension) is to ensure that there is a continuous **minimum** voltage at the product's power connector of 10.8 V dc, with a fully flat battery at 11 V dc.

Important:

Be aware that some products in your system (such as sonar modules) can create voltage peaks at certain times, which may impact the voltage available to other products during the peaks.

Grounding

Ensure that you observe any additional grounding advice provided in the product's documentation.

More information

It is recommended that best practice is observed in all vessel electrical installations, as detailed in the following standards:

- BMEA Code of Practice for Electrical and Electronic Installations in Boats

- NMEA 0400 Installation Standard
- ABYC E-11 AC & DC Electrical Systems on Boats
- ABYC A-31 Battery chargers and Inverters
- ABYC TE-4 Lightning Protection



Warning: Product grounding

Before applying power to this product, ensure it has been correctly grounded, in accordance with the instructions provided.



Warning: Positive ground systems

Do not connect this unit to a system which has positive grounding.

4.4 Element™ HV transducer connection

HV-series transducers can be connected directly to Element™ HV displays.

HV-100 connection

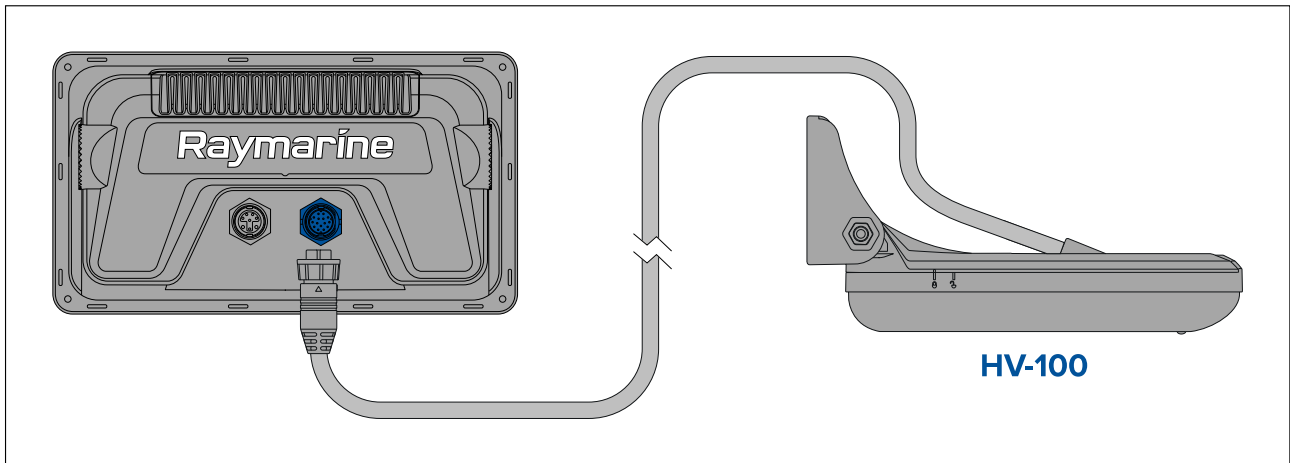

HV-300THP (all-in-one) connection

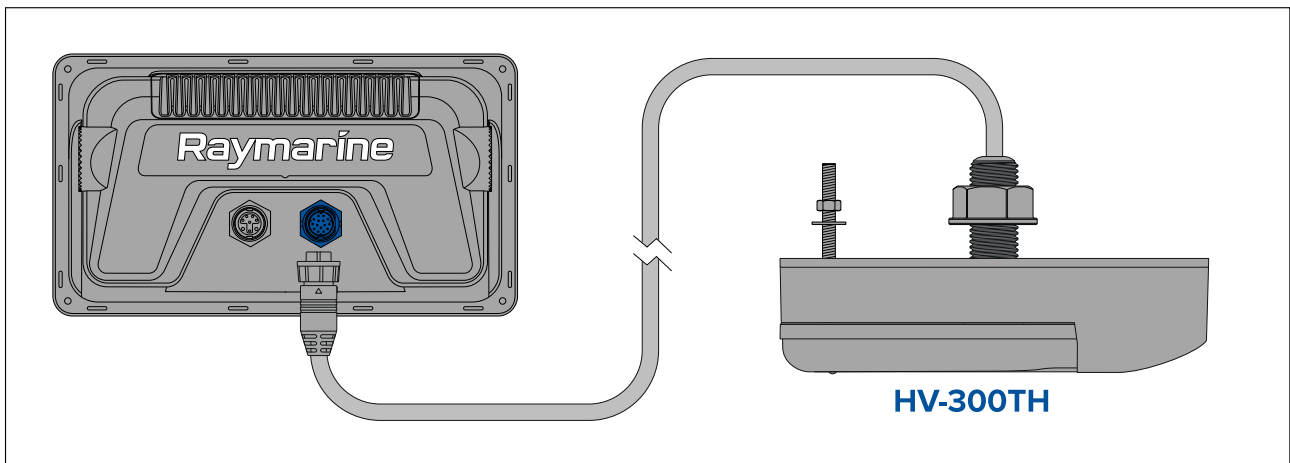

HV-300THP-P and HV-300THP-S (split pair) connection

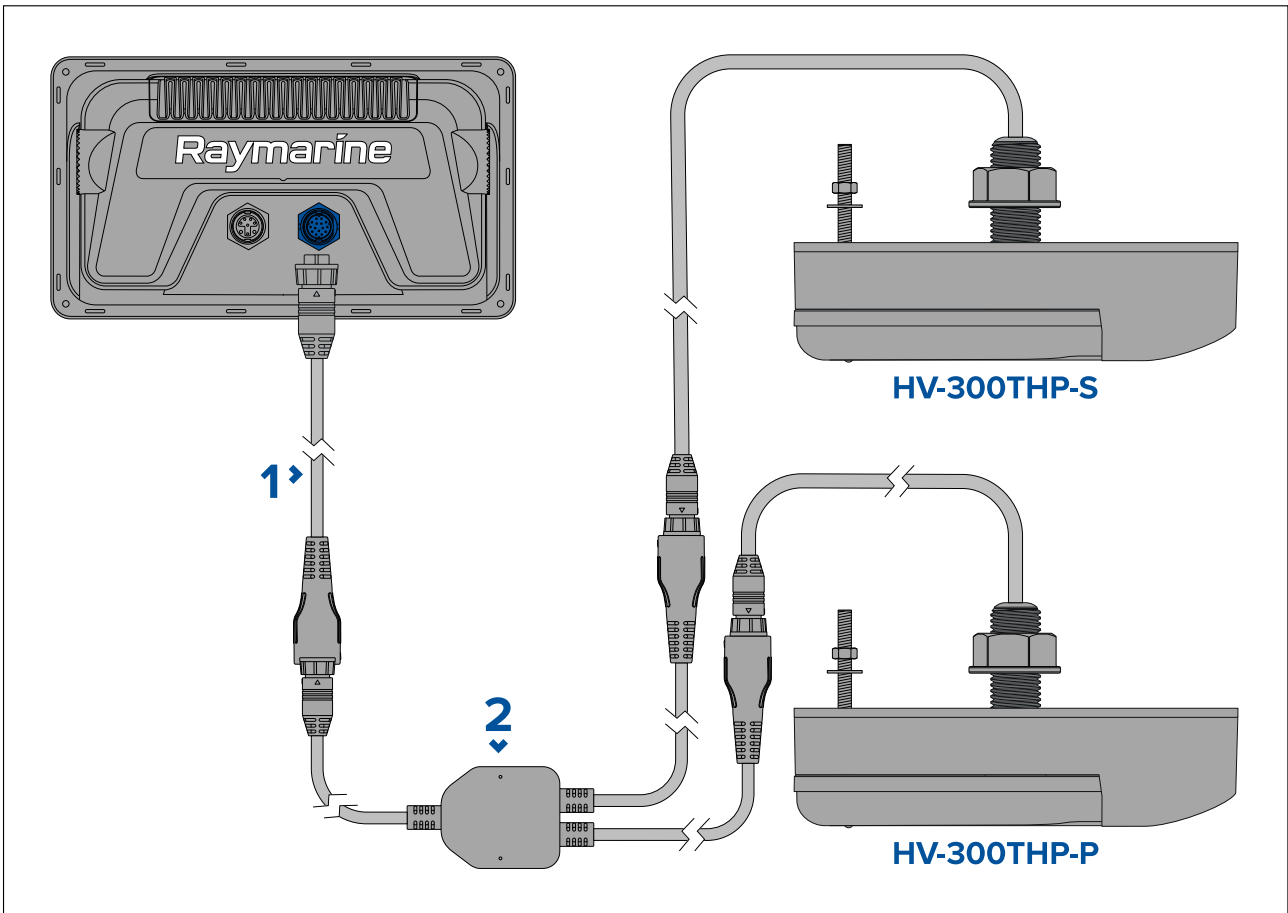

1. Extension cable (supplied with split pair sets of transducers).
2. Y-cable (supplied with split pair sets of transducers).

You can extend the length of transducer cables using a transducer extension cable.

HV-100 transducer extension cable

For best performance, cable runs should be kept to a minimum. However, for some installations it may be necessary to extend the transducer cable.

A 4 m (13.12 ft) HyperVision™ transducer extension cable (A80562) is available

It is recommended that a maximum of one cable extensions is used, with the total cable length not exceeding 10 m (32.81 ft).

Note:

The HyperVision™ transducer extension cable can only be used to connect a HV series transducer.

HV-300 transducer extension cable

For best performance, cable runs should be kept to a minimum. However, for some installations it may be necessary to extend the transducer cable.

A 4 m (13.12 ft) HyperVision™ transducer extension cable (A80562) is available

It is recommended that a maximum of one cable extensions is used, with the total cable run to each transducer not exceeding 6.3 m (20.67 ft).

Note:

The HyperVision™ transducer extension cable can only be used to connect a HV series transducer.

Caution: Transducer cable

- Do NOT use the transducer cable to lift or suspend the transducer; always support the transducer body directly during installation.
- Do NOT cut, shorten, or splice the transducer cable.
- Do NOT remove the connector.

If the cable is cut, it cannot be repaired. Cutting the cable will also void the warranty.

Cable routing

Cable routing requirements for the transducer cable.

Important:

To avoid interference, the cable must be routed as far away from VHF radio antenna devices and cables as possible.

- Check that the cable is long enough to reach the display it will be connected to. Optional extension cables are available, if required.
- Ensure there is enough slack in the transducer cable, at the transducer end, to allow the transducer to pivot up and down during adjustment.
- If you intend to route the cable through the transom then you should use the supplied escutcheon plate to cover the hole..
- Secure the cable at regular intervals using the supplied cable clips.
- Any excess cable should be coiled up at a convenient location.

4.5 Element™ HV legacy transducer connection

When connecting a legacy transducer you must use the correct adaptor cable and, where required an extension cable that is compatible with the legacy transducer.

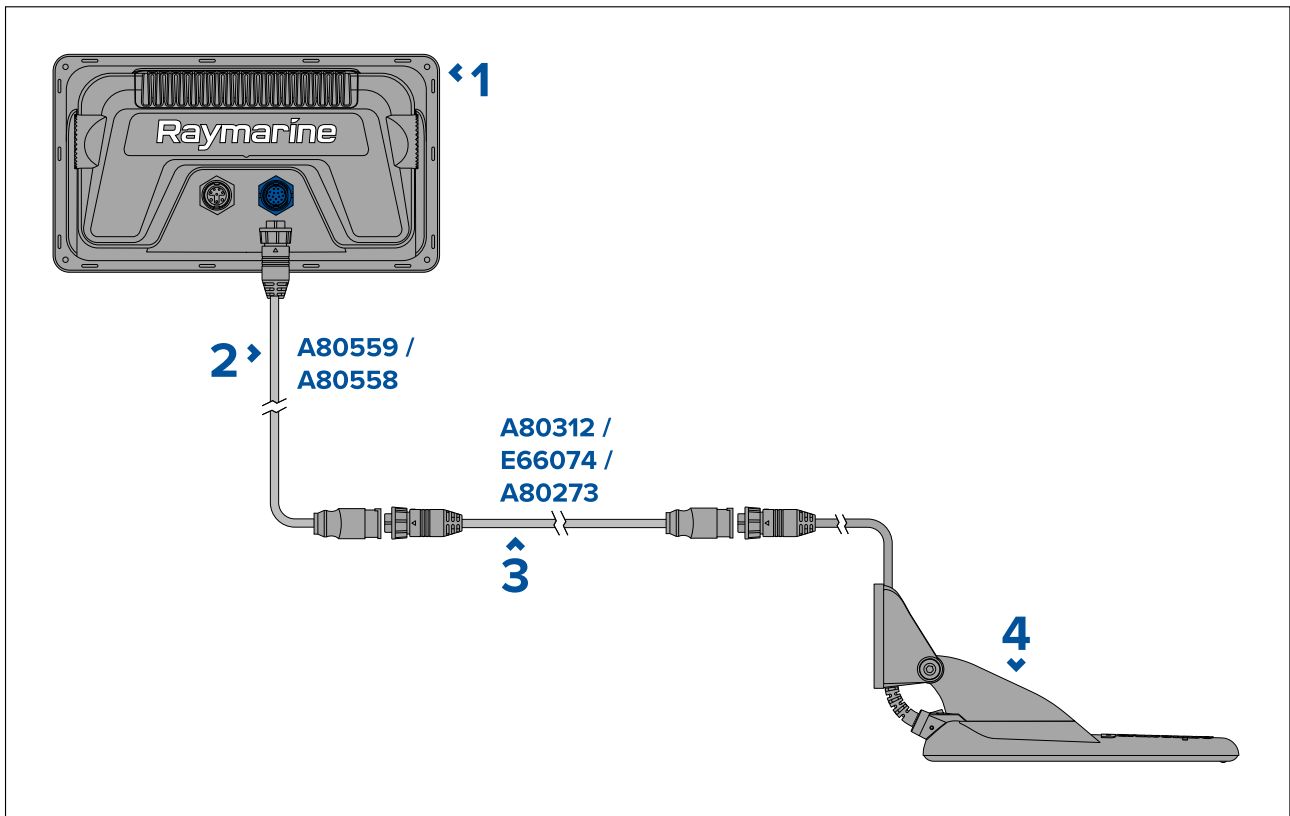

1. Element™ HV display — Connects to adaptor cable..
2. Adaptor cable (i.e.: A80559 or A80558) — Connects to the display and extension cable or transducer.
3. Extension cable (i.e.: A80312, E66074 or A80273) — Connects between transducer and adaptor cable.
4. Example legacy transducer — Connects to adaptor cable or extension cable.

Legacy transducer extension cables

When connecting a compatible legacy transducer to an Element display, using an adaptor cable: if the cable run requires extending, you must use an extension cable which is compatible with your transducer.

Important: The HyperVision™ extension cable cannot be used to extend the cable run of legacy transducers.	
Legacy transducer	Compatible extension cable
Dragonfly® transducers	A80312 — 4 m (13.1 ft) Dragonfly® transducer extension cable. Note: Power supply wires should be isolated and protected from shorting or water ingress.
DownVision™ transducers	E66074 — 3 m (9.84 ft) DownVision™ transducer extension cable.
High CHIRP sonar transducers	A80273 — 4 m (13.1 ft) CPT-S transducer extension cable.

4.6 Element™ S transducer connection

Conical high CHIRP sonar transducers can be connected directly to Element™ S variant displays.

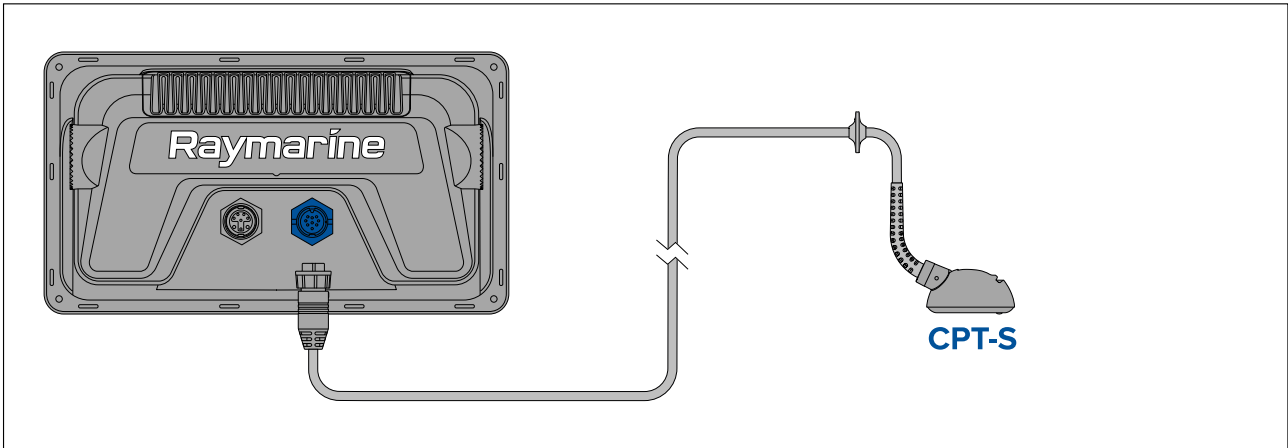

You can extend the length of CPT-S transducer cables using a transducer extension cable A80273 (4 m (13.1 ft) CPT-S transducer extension cable).

4.7 SeaTalkng[®] connection

The display can be connected to a SeaTalkng[®] backbone, using the DeviceNet connector included in the Power/NMEA 2000 cable and an adaptor cable (not supplied).

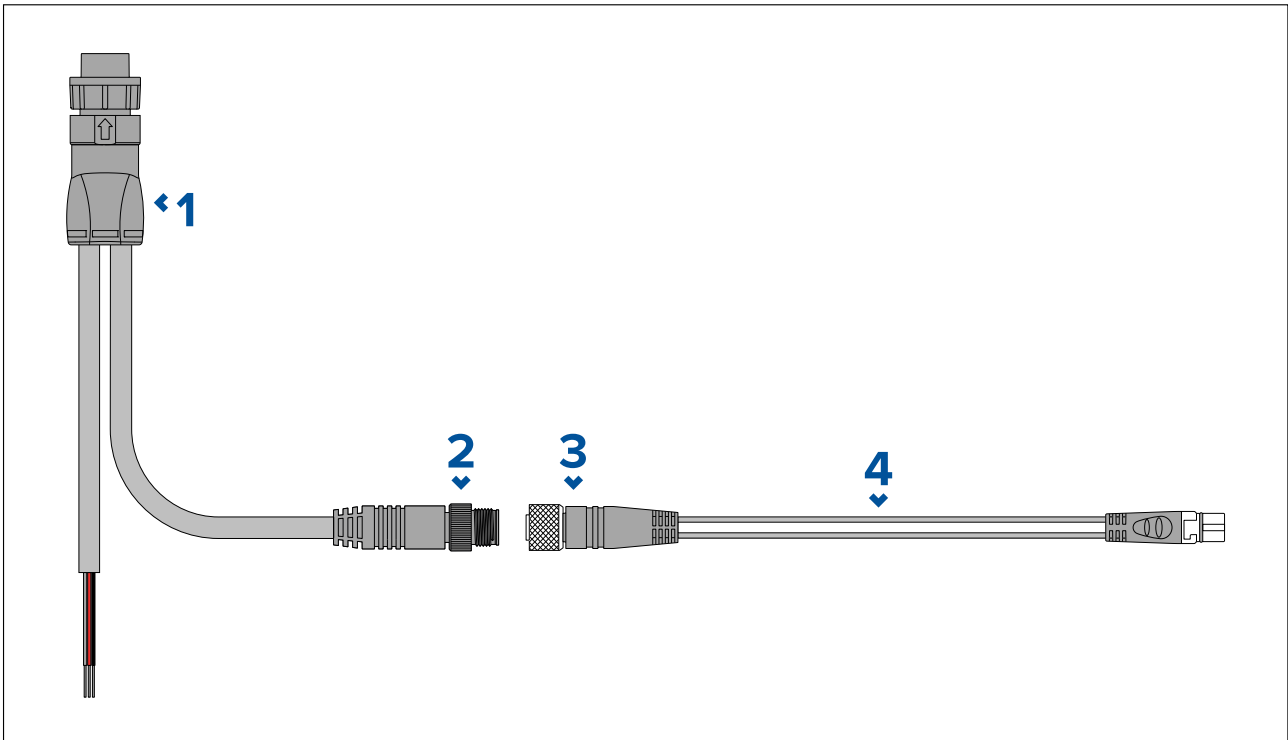

1. Supplied power/NMEA 2000 cable.
2. DeviceNet (Micro-C 5-pin male) cable connector.
3. DeviceNet (5-pin female) cable connector.
4. SeaTalkng[®] to DeviceNet adaptor cable (A06045 / A06075) connects to SeaTalkng[®] backbone.

Note:

1. SeaTalkng[®] devices must be connected to a correctly terminated backbone that the display is also connected to. Products cannot be connected directly to the display.
2. Refer to the instructions supplied with your SeaTalkng[®] product for details on creating a backbone.

Data compatibility

In addition to products listed as compatible in this document, your product can also receive and display data from other NMEA 2000 devices.

For data to be displayed onscreen the display must receive data from NMEA 2000 devices using supported NMEA 200 PGN messages.

A list of NMEA 2000 PGN messages that are supported by your display can be found in the appendix of this document: [p.87 — SeaTalkng[®] cables and accessories](#)

NMEA 2000 connection

The display can be connected directly to a NMEA 2000 backbone, using the DeviceNet connector included in the Power/NMEA 2000 cable.

Connection to a NMEA 2000 backbone enables supported data to be transmitted and / or received by the display.

Supported SeaTalkng[®] products can be connected to a NMEA 2000 network using a SeaTalkng[®] to DeviceNet adaptor cables.

4.8 SeaTalkng® system example

An example SeaTalkng® system is provided below. Connection to a network provides the display with data from other connected devices.

Note:

The details below are provided as an example only and does not reflect all products that may be present on the SeaTalkng® network; e.g.: in order to calibrate wind data an instrument display would be required.

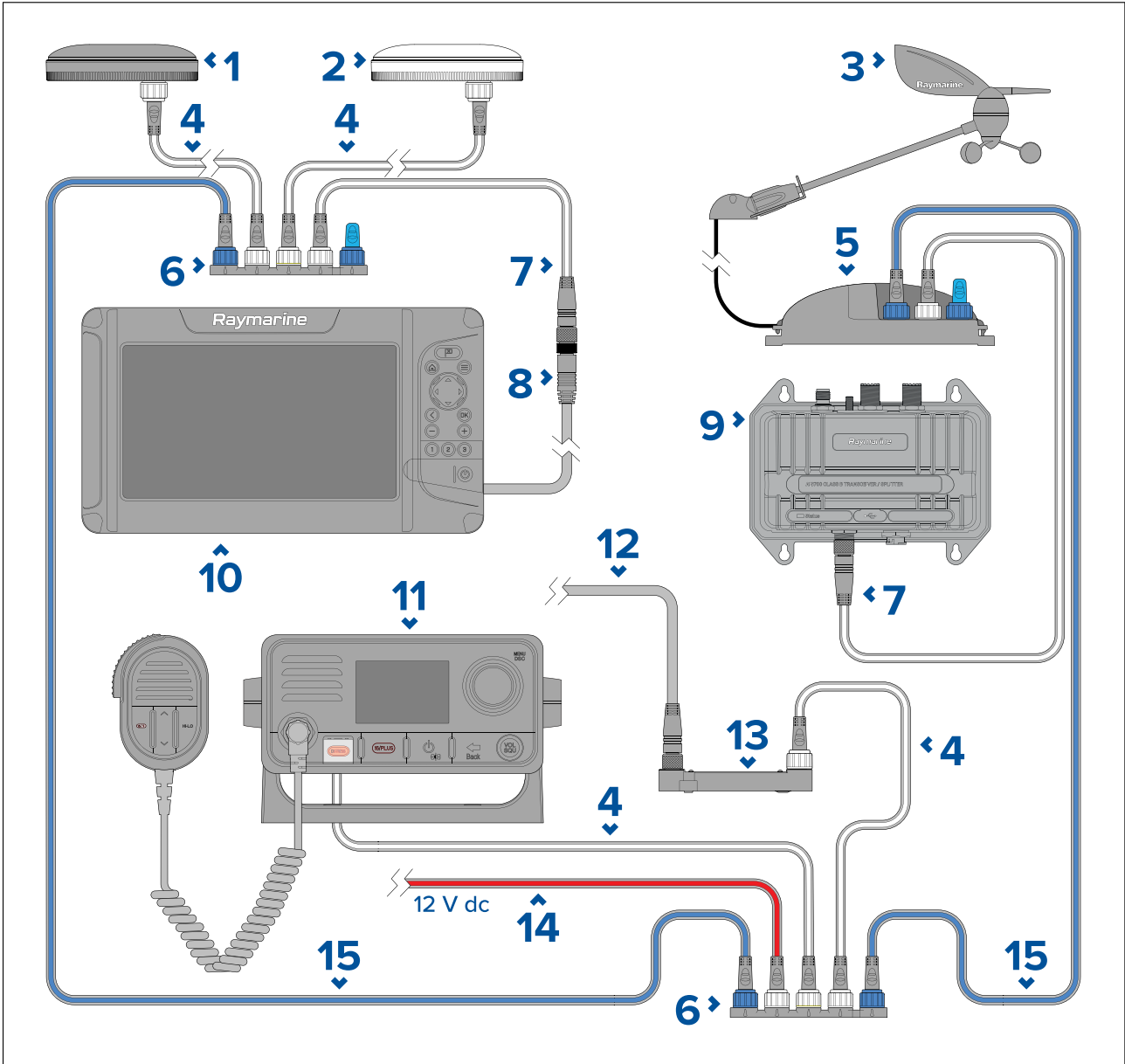

1. EV-1 heading sensor.
2. RS150 GNSS receiver.
3. Wind vane transducer.
4. SeaTalkng® spur cables.
5. iTC-5 convertor.
6. SeaTalkng® 5-way connector block.
7. DeviceNet to SeaTalkng® adaptor cable.
8. DeviceNet connection on display's power / NMEA 2000 cable.
9. AIS700.
10. Element™ display.
11. SeaTalkng® / NMEA 2000 VHF DSC Radio (GPS / GNSS position data can be transmitted from the display and used by a compatible VHF DSC radio).

12. DeviceNet connection to vessel's engine management system.
13. ECI-100.
14. SeaTalkng[®] power cable (connects to vessel's 12 V dc power supply).
15. SeaTalkng[®] backbone cables.

Note:

- SeaTalkng[®] instrument displays and pilot controllers can be present on the same backbone; however data will NOT be synchronized with the Element display.
- Up to 2 Element displays can be present on the same backbone; however data will NOT be synchronized between Element displays.
- An Element display can NOT be connected to the same backbone as a Multifunction display (MFD, e.g. Axiom, or a Series, c Series, e Series, eS Series, or gS Series).

For a list of SeaTalkng[®] cables and accessories refer to [p.87 — SeaTalkng[®] cables and accessories](#).

4.9 Pairing a Quantum™ radar scanner

You can connect a Quantum™ radar scanner to your display using the Wi-Fi connection.

Pre-requisites:

- Ensure you have installed and connected your Quantum™ radar scanner to a power supply following the instructions supplied with the radar scanner.
- Ensure you know your Quantum™ radar scanner's SSID and passcode.

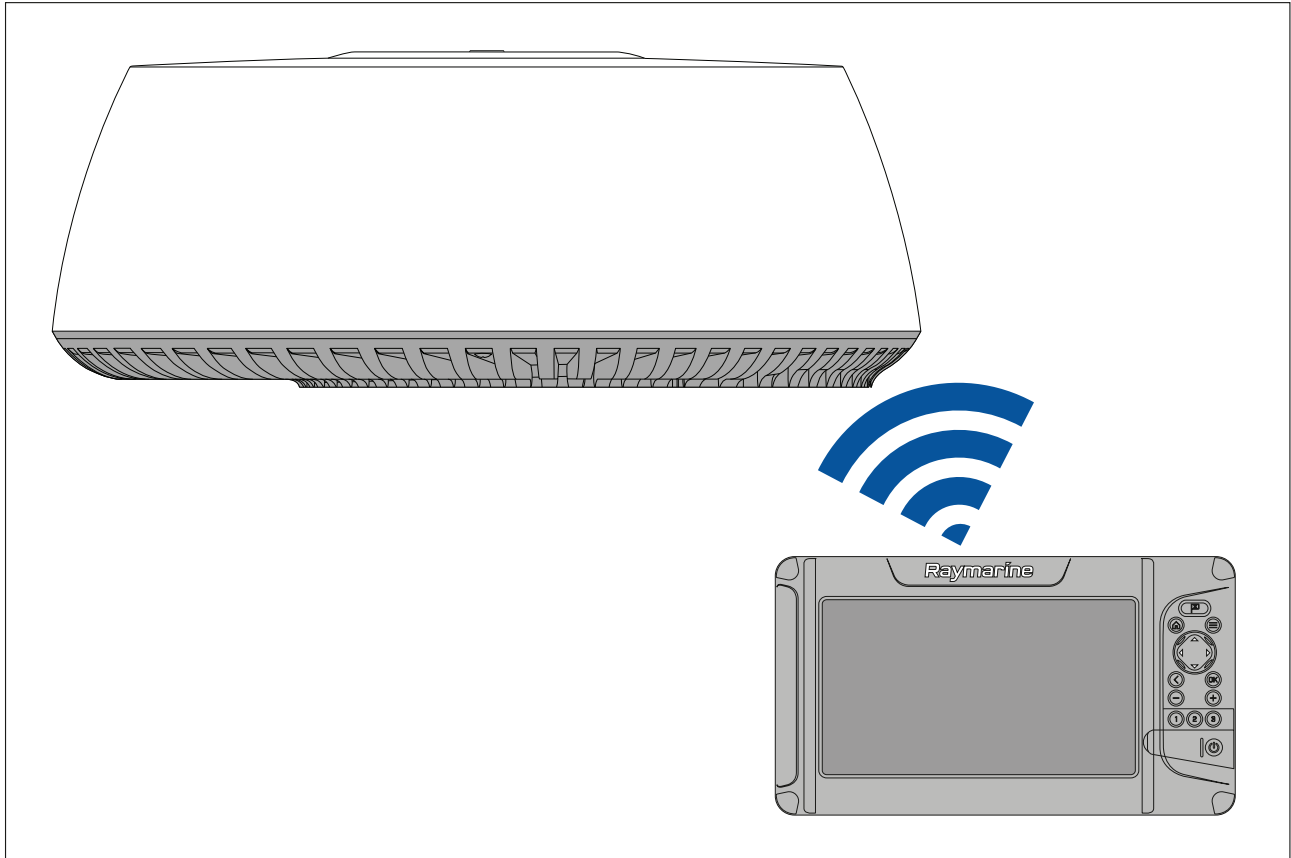

1. Select **Pair with Quantum** from the **This display** tab: **Homescreen** > **Settings** > **This display** > **Quantum Radar:** > **Pair with Quantum**.
2. Enter the SSID and passcode for your Quantum™ radar.
3. Select **Connect**.
4. Follow any onscreen instructions to continue pairing with your Quantum™ radar.

The pairing process may take several minutes to complete.

For more information on the Quantum™ radar pairing process (including troubleshooting information), refer to your Quantum™ radar documentation.

4.10 Element autopilot connection

You can connect an Element™ display to the same network as an Evolution™ autopilot system. An Element™ display can send navigation commands / data to a compatible autopilot controller.

Note:

Navigation commands require acknowledgement from the autopilot controller.

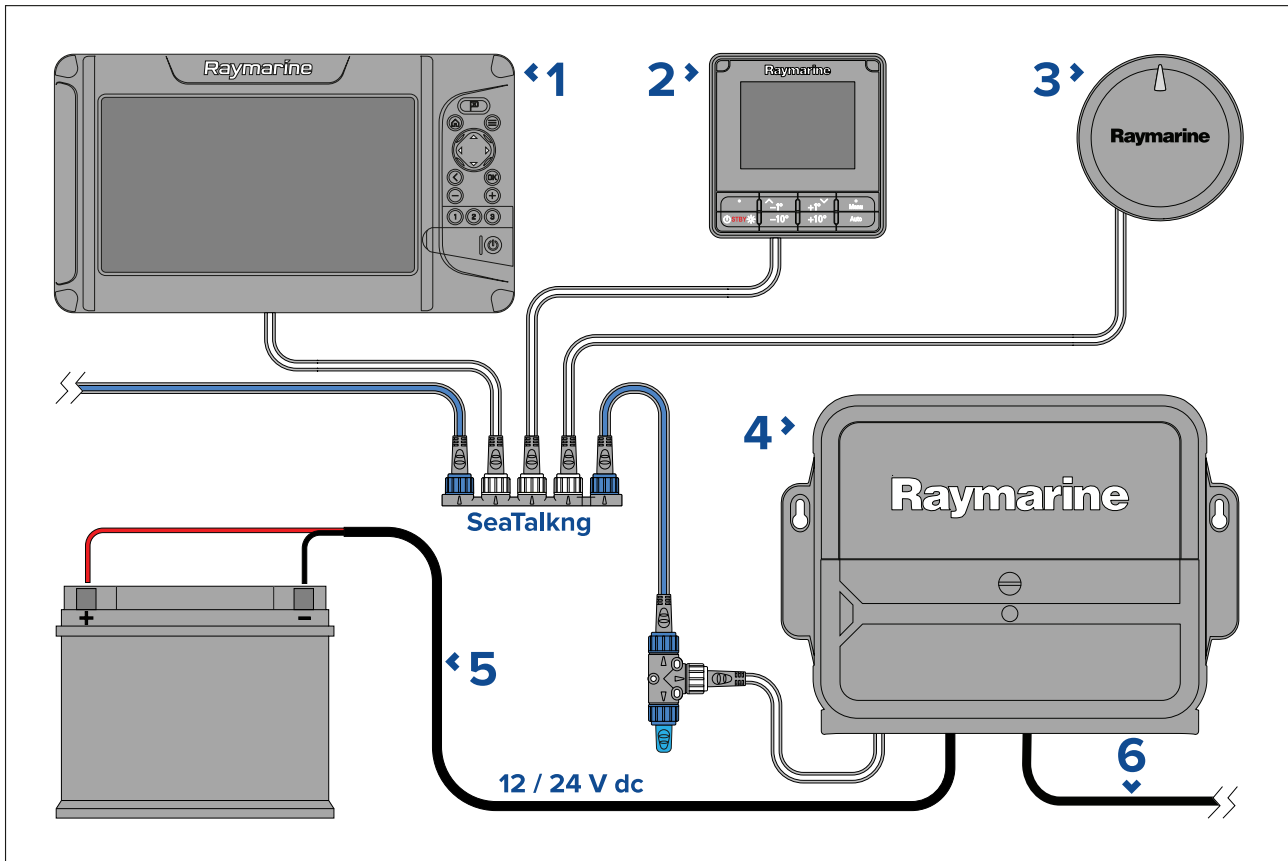

1. Element™ display.
2. Pilot controller (e.g.: p70s)
3. EV sensor (e.g.: EV-1)
4. ACU (e.g.: ACU-200)
5. Power supply to ACU, also supplies 12 V dc to SeaTalkng™ network..
6. Cable to drive unit.

Chapter 5: Maintaining your display

Chapter contents

- [5.1 Service and maintenance on page 56](#)
- [5.2 Product care on page 57](#)

5.1 Service and maintenance

Caution: Service and maintenance

This product contains no user serviceable components. Please refer all maintenance and repair to authorized Raymarine dealers. Unauthorized repair may affect your warranty.



Warning: High voltage

This product contains high voltage. Adjustments require specialized service procedures and tools only available to qualified service technicians. There are no user serviceable parts or adjustments. The operator should never remove the cover or attempt to service the product.



Warning: FCC Warning (Part 15.21)

Changes or modifications to this equipment not expressly approved in writing by Raymarine Incorporated could violate compliance with FCC rules and void the user's authority to operate the equipment.

5.2 Product care

Caution: Sun covers

- If your product is supplied with a sun cover, to protect against the damaging effects of ultraviolet (UV) light, always fit the sun cover when the product is not in use.
- To avoid potential loss, sun covers must be removed when travelling at high speed, whether in water or when the vessel is being towed.

Routine equipment checks

It is recommended that you perform the following routine checks, on a regular basis, to ensure the correct and reliable operation of your equipment:

- Examine all cables for signs of damage or wear and tear.
- Check that all cables are securely connected.

Caution: Product cleaning

When cleaning products:

- Lightly rinse or flush with clean, cool fresh water.
- If your product has a display screen, do NOT wipe the screen with a dry cloth, as this could scratch the screen coating.
- Do NOT use: abrasive, acidic, ammonia, solvent or other chemical based cleaning products.
- Do NOT use a jet wash.

Cleaning the display case

The display unit is a sealed unit and does not require regular cleaning. If it is necessary to clean the unit, follow this basic procedure:

1. Switch off the power to the display.
2. Wipe the display with a clean, soft cloth (a microfibre cloth is ideal).
3. If necessary, use a mild detergent to remove grease marks.

Note: Do NOT use solvents or detergents on the screen itself.

Cleaning the display screen

A coating is applied to the display screen. This makes it water repellent, and prevents glare. To avoid damaging this coating, follow this procedure:

1. Switch off the power to the display.
2. Rinse the screen with fresh water to remove all dirt particles and salt deposits.
3. Allow the screen to dry naturally.
4. If any smears remain, very gently wipe the screen with a clean microfibre cleaning cloth.

Cleaning the sun cover

The supplied sun cover features an adhesive surface. In certain conditions unwanted contaminants may stick to this surface. To avoid damaging the monitor display, clean the sun cover regularly following this procedure:

1. Carefully remove the sun cover from the display.
2. Rinse the sun cover with fresh water to remove all dirt particles and salt deposits.
3. Allow the sun cover to dry naturally.

Chapter 6: Troubleshooting

Chapter contents

- [6.1 Troubleshooting on page 60](#)
- [6.2 Power up troubleshooting on page 61](#)
- [6.3 GPS / GNSS troubleshooting on page 63](#)
- [6.4 Sonar troubleshooting on page 64](#)
- [6.5 Wi-Fi troubleshooting on page 66](#)

6.1 Troubleshooting

The troubleshooting information provides possible causes and corrective action required for common problems associated with installation and operation of your product.

Before packing and shipping, all Raymarine products are subjected to comprehensive testing and quality assurance programs. If you do experience problems with your product this section will help you to diagnose and correct problems in order to restore normal operation.

If after referring to this section you are still having problems with your product, please refer to the Technical support section of this manual for useful links and Raymarine Product Support contact details.

6.2 Power up troubleshooting

Product does not turn on or keeps turning off

Possible causes	Possible solutions
Blown fuse / tripped breaker.	<ol style="list-style-type: none"> 1. Check condition of relevant fuses and breakers and connections, replace if necessary. (Refer to the <i>Technical Specification</i> section of your product's installation instructions for fuse ratings.) 2. If fuse keeps blowing check for cable damage, broken connector pins or incorrect wiring.
Poor / damaged / insecure power supply cable / connections	<ol style="list-style-type: none"> 1. Check that the power cable connector is correctly orientated and fully inserted into the display connector and locked in position. 2. Check the power supply cable and connectors for signs of damage or corrosion, and replace if necessary. 3. With the display turned on, try flexing the power cable near to the display connector to see if this causes the unit to restart or lose power. Replace if necessary. 4. Check the vessel's battery voltage and the condition of the battery terminals and power supply cables, ensuring connections are secure, clean and free from corrosion. Replace if necessary. 5. With the product under load, using a multi-meter, check for high voltage drop across all connectors / fuses etc, and replace if necessary.
Incorrect power connection	The power supply may be wired incorrectly, ensure the installation instructions have been followed.

Product will not start up (restart loop)

Possible causes	Possible solutions
Power supply and connection	See possible solutions from the table above, entitled 'Product does not turn on or keeps turning off'.
Software corruption	<ol style="list-style-type: none"> 1. In the unlikely event that the product's software has become corrupted, try downloading and installing the latest software from the Raymarine website. 2. On display products, as a last resort, attempt to perform a 'Power on Reset'. Be aware that this will delete all settings / presets and user data (such as waypoints and tracks), and revert the unit back to factory defaults.

Performing a power on reset

As part of troubleshooting you may be requested to perform a power on reset.

<p>Important:</p> <p>Before performing a power on reset ensure you have backed up your settings and user data to a memory card.</p>
--

With the display powered off:

1. Press and hold the **Home** button.
2. Press and hold the **Power** button until the display beeps.
3. Let go of the **Power** button.
4. When the Raymarine logo appears, let go of the **Home** button.
5. Use the **Down** button to highlight **Wipe data/factory reset**.
6. Press the **OK** button.
7. Use the **Down** button to highlight **Yes**.
8. Press the **OK** button.

The display will now be reset to factory default settings and all user data will be removed. 'Data wipe complete' is displayed at the bottom of the screen when the reset is finished.

9. Ensure **Reboot system now** is highlighted.
10. Press the **OK** button.

6.3 GPS / GNSS troubleshooting

Potential problems with the GPS / GNSS receiver and possible causes and solutions are described here.

Problem	Possible causes	Possible solutions
“No Fix” status icon is displayed. or display keeps losing position fix.	Geographic location or prevailing conditions preventing satellite fix.	Check periodically to see if a fix is obtained in better conditions or another geographic location.
	Display in poor location. For example: <ul style="list-style-type: none">• Below decks.• Close proximity to transmitting equipment such as VHF radio.	Ensure the display has an unobstructed view of the sky.

Note:

A GPS / GNSS status screen is accessible from the display’s Homescreen. This provides satellite signal strength and other relevant information.

6.4 Sonar troubleshooting

Problems with the sonar and their possible causes and solutions are described here.

No transducer connected message displayed

Possible causes	Possible solutions
No transducer connected.	Connect a transducer and reboot the display.
Wrong transducer type selected during initial start up wizard.	<p>Try selecting a sonar channel:</p> <ol style="list-style-type: none"> 1. Press the Menu button. 2. Use the Up/Down buttons to highlight a sonar channel. 3. Press the OK button. <p>If the message persists and there is a transducer connected then there may be a transducer connection fault.</p>
Damaged connectors/cabling	<ol style="list-style-type: none"> 1. Check that the transducer connector pins on the back of the display are not bent or broken. 2. Check that the transducer cable connector is correctly orientated and fully inserted into the display connector and locked in position. 3. Check the condition of the transducer cabling and connectors for signs of damage or corrosion, and replace if necessary.

Scrolling image is not being displayed or is intermittent

Possible causes	Possible solutions
Damaged connectors/cabling	<ol style="list-style-type: none"> 1. Check that the transducer connector pins on the back of the display are not bent or broken. 2. Check that the transducer cable connector is correctly orientated and fully inserted into the display connector and locked in position. 3. Check the condition of the transducer cabling and connectors for signs of damage or corrosion, and replace if necessary.
Transducer damaged or fouled	Check the condition of the transducer ensuring it is not damaged and is free from debris/fouling, clean or replace as necessary.
Incompatible transducer fitted.	Ensure the connected transducer is compatible with your system.

No depth reading / lost bottom lock

Possible causes	Possible solutions
Transducer location	Check that the transducer has been installed in accordance with the instructions that were provided with the transducer.
Transducer angle	If the transducer angle is too great the beam can miss the bottom, adjust transducer angle and recheck.
Transducer kicked-up	If the transducer has a kick-up mechanism, check that it has not kicked up due to hitting an object.
Transducer damaged or fouled	Check the condition of the transducer ensuring it is not damaged and is free from debris/fouling, clean or replace as necessary.

Possible causes	Possible solutions
Damaged connectors/cabling	<ol style="list-style-type: none"> 1. Check that the transducer connector pins on the back of the display are not bent or broken. 2. Check that the transducer cable connector is correctly orientated and fully inserted into the display connector and locked in position. 3. Check the condition of the transducer cabling and connectors for signs of damage or corrosion, and replace if necessary.
Vessel speed too high	Slow vessel speed and recheck.
Bottom too shallow or too deep	<p>The bottom depth may be outside of the transducers depth range, move vessel to shallower or deeper waters as relevant and recheck.</p> <p>Transducer minimum and maximum depths can be found in the technical specification for your transducer.</p>

Poor / problematic image

Possible causes	Possible solutions
Vessel stationary	Fish arches are not displayed if the vessel is stationary; fish will appear on the display as straight lines.
Cursor mode is active	The scrolling screen is paused in Cursor mode, press the Back button to resume scrolling.
Sensitivity settings may be inappropriate for present conditions.	Check and adjust sensitivity settings or perform a Sonar reset.
Damaged connectors/cabling	<ol style="list-style-type: none"> 1. Check that the transducer connector pins on the back of the display are not bent or broken. 2. Check that the transducer cable connector is correctly orientated and fully inserted into the display connector and locked in position. 3. Check the condition of the transducer cabling and connectors for signs of damage or corrosion, and replace if necessary.
Transducer location	<ul style="list-style-type: none"> • Check that the transducer has been installed in accordance with the instructions that were provided with the transducer. • If a transom mount transducer is mounted too high on the transom it may be lifting out of the water, check that the transducer face is fully submerged when planing and turning.
Transducer kicked-up	If the transducer has a kick-up mechanism, check that it has not kicked up due to hitting an object.
Transducer damaged or fouled	Check the condition of the transducer ensuring it is not damaged and is free from debris/fouling, clean or replace as necessary.
Turbulence around the transducer at higher speeds may affect transducer performance	Slow vessel speed and recheck.
Interference from another transducer	<ol style="list-style-type: none"> 1. Turn off the transducer causing the interference. 2. Reposition the transducers so they are farther apart.

6.5 Wi-Fi troubleshooting

Before troubleshooting problems with your Wi-Fi connection, ensure that you have followed the Wi-Fi location requirements guidance provided in the relevant installation instructions and performed a power cycle/reboot of the devices you are experiencing problems with.

Cannot find router network

Possible cause	Possible solutions
Router out of range or signal blocked.	<ul style="list-style-type: none"> Ensure router is broadcasting and in range of your display. If necessary, move router and display closer together and then turn the display's Wi-Fi off and back on again. If possible, remove any obstructions and then turn the display's Wi-Fi off and back on again.
Display Wi-Fi disabled.	Ensure Wi-Fi is enabled on the Display.
Router problem.	If possible, power cycle the router and then turn the display's Wi-Fi off and back on again.
Device not broadcasting.	<ol style="list-style-type: none"> If possible, enable broadcasting in the router's settings. You may still be able to connect to the router, when it is not broadcasting, by manually entering the router's network name and password in the Display's Wi-Fi settings page.
Router's Wi-Fi network is incompatible	The Display's Wi-Fi can only connect to 2.4 GHz networks.

Cannot connect to network

Possible cause	Possible solutions
Trying to connect to the wrong Wi-Fi network.	Ensure you are trying to connect to the correct Wi-Fi network; the Wi-Fi network's name can be found in the router's settings.
Incorrect network credentials.	Ensure you are using the correct password; the Wi-Fi network's password can be found in the router's settings.
Bulkheads, decks and other heavy structure can degrade and even block the Wi-Fi signal. Depending on the thickness and material used, it may not always be possible to pass a Wi-Fi signal through certain structures.	<ol style="list-style-type: none"> Try repositioning the display and if possible the router, so the structure is removed from the direct line of sight between the devices.
Interference being caused by other Wi-Fi enabled or older Bluetooth enabled devices (Bluetooth and Wi-Fi both operate in the 2.4 GHz frequency range, some older Bluetooth devices may interfere with Wi-Fi signals.)	<ol style="list-style-type: none"> If possible, change the Wi-Fi Channel that your router is using and retry the connection. You can use free Wi-Fi analyzer apps on a smart device to help you choose a better channel (channel with least traffic). Temporarily disable each wireless device in turn until you have identified the device causing the interference.

Possible cause	Possible solutions
<p>Interference caused by other devices that use the 2.4 GHz frequency. See following list of some common devices that use the 2.4 GHz frequency:</p> <ul style="list-style-type: none"> • Microwave ovens • Fluorescent lighting • Cordless phones / baby monitors • Motion sensors 	<p>Temporarily switch off each device in turn until you have identified the device causing the interference, then remove or reposition the offending device(s).</p>
<p>Interference caused by electrical and electronic devices and associated cabling could generate an electromagnetic field which may interfere with the Wi-Fi signal.</p>	<p>Temporarily switch off each item in turn until you have identified the device causing the interference, then remove or reposition the offending device(s).</p>

Connection extremely slow and / or keeps dropping out

Possible cause	Possible solutions
<p>Wi-Fi performance degrades over distance, so products farther away will receive less network bandwidth. Products installed close to their maximum Wi-Fi range will experience slow connection speeds, signal dropouts or not being able to connect at all.</p>	<p>Move display closer to router.</p>
<p>Interference being caused by other Wi-Fi enabled or older Bluetooth enabled devices (Bluetooth and Wi-Fi both operate in the 2.4 GHz frequency range, some older Bluetooth devices may interfere with Wi-Fi signals.)</p>	<ol style="list-style-type: none"> 1. If possible, change the Wi-Fi Channel that your router is using and retry the connection. You can use free Wi-Fi analyzer apps on a smart device to help you choose a better channel (channel with least traffic).. 2. Temporarily switch off each item in turn until you have identified the device causing the interference, then remove or reposition the offending device(s).
<p>Interference from devices on other vessels. When in close proximity to other vessels (for example, when moored up in a marina), many other Wi-Fi signals may be present.</p>	<ol style="list-style-type: none"> 1. If possible, change the Wi-Fi Channel that your router is using and retry the connection. You can use free Wi-Fi analyzer apps on a smart device to help you choose a better channel (channel with least traffic). 2. If possible, move your vessel to a location with less Wi-Fi traffic.

Network connection established but no data

Possible cause	Possible solutions
<p>No internet connection to router.</p>	<p>Ensure that your display is connected to a network with an internet connection.</p>

Chapter 7: Technical support

Chapter contents

- [7.1 Raymarine product support and servicing on page 70](#)
- [7.2 Learning resources on page 73](#)

7.1 Raymarine product support and servicing

Raymarine provides a comprehensive product support service, as well as warranty, service, and repairs. You can access these services through the Raymarine website, telephone, and e-mail.

Product information

If you need to request service or support, please have the following information to hand:

- Product name.
- Product identity.
- Serial number.
- Software application version.
- System diagrams.

You can obtain this product information using diagnostic pages of the connected MFD.

Servicing and warranty

Raymarine offers dedicated service departments for warranty, service, and repairs.

Don't forget to visit the Raymarine website to register your product for extended warranty benefits: <http://www.raymarine.co.uk/display?id=788>.

Region	Contact
United Kingdom (UK), EMEA, and Asia Pacific	<ul style="list-style-type: none">• E-Mail: emea.service@raymarine.com• Tel: +44 (0)1329 246 932
United States (US)	<ul style="list-style-type: none">• E-Mail: rm-usrepair@flir.com• Tel: +1 (603) 324 7900

Web support

Please visit the “Support” area of the Raymarine website for:

- **Manuals and Documents** — <http://www.raymarine.com/manuals>
- **Technical support forum** — <http://forum.raymarine.com>
- **Software updates** — <http://www.raymarine.com/software>

Worldwide support

Region	Contact
United Kingdom (UK), EMEA, and Asia Pacific	<ul style="list-style-type: none">• E-Mail: support.uk@raymarine.com• Tel: +44 (0)1329 246 777
United States (US)	<ul style="list-style-type: none">• E-Mail: support@raymarine.com• Tel: +1 (603) 324 7900 (Toll-free: +800 539 5539)
Australia and New Zealand (Raymarine subsidiary)	<ul style="list-style-type: none">• E-Mail: aus.support@raymarine.com• Tel: +61 2 8977 0300
France (Raymarine subsidiary)	<ul style="list-style-type: none">• E-Mail: support.fr@raymarine.com• Tel: +33 (0)1 46 49 72 30
Germany (Raymarine subsidiary)	<ul style="list-style-type: none">• E-Mail: support.de@raymarine.com• Tel: +49 (0)40 237 808 0
Italy (Raymarine subsidiary)	<ul style="list-style-type: none">• E-Mail: support.it@raymarine.com• Tel: +39 02 9945 1001
Spain (Authorized Raymarine distributor)	<ul style="list-style-type: none">• E-Mail: sat@azimut.es• Tel: +34 96 2965 102
Netherlands (Raymarine subsidiary)	<ul style="list-style-type: none">• E-Mail: support.nl@raymarine.com• Tel: +31 (0)26 3614 905

Region	Contact
Sweden (Raymarine subsidiary)	<ul style="list-style-type: none"> E-Mail: support.se@raymarine.com Tel: +46 (0)317 633 670
Finland (Raymarine subsidiary)	<ul style="list-style-type: none"> E-Mail: support.fi@raymarine.com Tel: +358 (0)207 619 937
Norway (Raymarine subsidiary)	<ul style="list-style-type: none"> E-Mail: support.no@raymarine.com Tel: +47 692 64 600
Denmark (Raymarine subsidiary)	<ul style="list-style-type: none"> E-Mail: support.dk@raymarine.com Tel: +45 437 164 64
Russia (Authorized Raymarine distributor)	<ul style="list-style-type: none"> E-Mail: info@mikstmarine.ru Tel: +7 495 788 0508

Viewing hardware and software details (LightHouse™ Sport)

The **Getting started** tab in the homescreen **Settings** menu provides hardware and software information about your display.

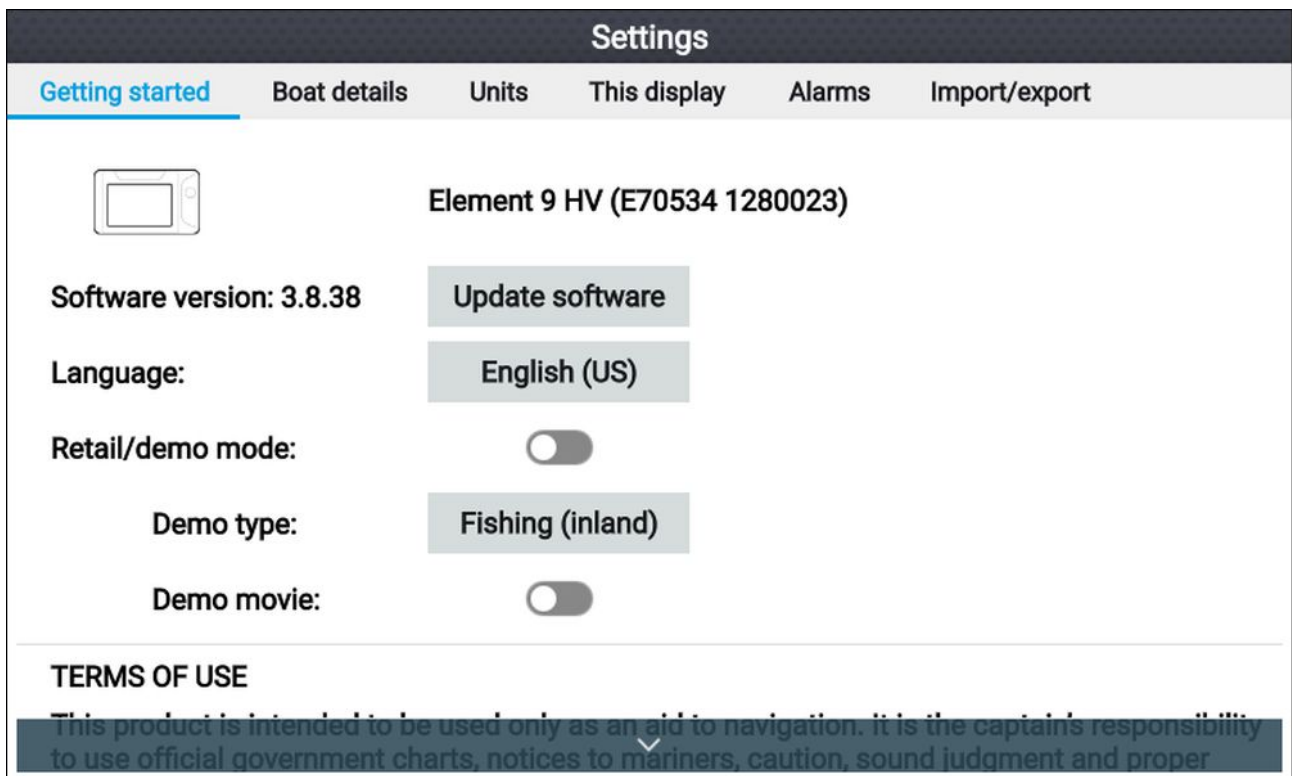

1. Select the **Settings** icon from the Homescreen.

Viewing product information

You can view detailed product information about your display.

Product information	
Element 12 HV E70536 0190026	
Save data	
Product info	
CPU revision:	quad core 1GB
Hardware revision:	7
Product family:	Element
Product ID:	E70536
Supply voltage:	14.1V
System Up Time:	1hours
Cartography info	
CMAP base map version:	1.0-00006
Navionics base map version:	1.0-00006
Rx5 base map version:	1.0-00006
Software info	
Application version:	3.9.57
CMAP library version:	CI-2.0.0R SDK-15.0.0R (04/09/2017)
Crash logs:	1
Kernel version:	3.18.31-perf (Fri Apr 5 05:39:28 BST 2019)
Navionics library version:	NI_01.03.40.21_UV_2337_CI_03.09
Platform version:	0.00.111
Power micro version:	200
Product bundle version:	3.9.57

1. Select the **Settings** icon from the **Homescreen**.
2. Select the **This display** tab.
3. Select **About this product** from the **DIAGNOSTICS** section.
4. If the **Save data** button is highlighted press the **Left** button.
5. Use the **Up** button and **Down** button to scroll through the available information.

Saving product information

The information displayed on the Product information page can be saved to memory card.



With the Product info page displayed:

1. Use the **Right** button to select **Save data**.
2. Enter a filename for the data using the onscreen keyboard, or keep the default filename.
3. Select **Save**.
4. Select **Eject card** to safely remove the memory card, or select **OK** to return to the **Product information** page.

7.2 Learning resources

Raymarine has produced a range of learning resources to help you get the most out of your products.

Video tutorials

	<p>Raymarine official channel on YouTube:</p> <ul style="list-style-type: none">• YouTube <p>LightHouse™ 3 tips and tricks:</p> <ul style="list-style-type: none">• Raymarine website
	<p>Video Gallery:</p> <ul style="list-style-type: none">• Raymarine website

Note:

- Viewing the videos requires a device with an Internet connection.
- Some videos are only available in English.

Training courses

Raymarine regularly runs a range of in-depth training courses to help you make the most of your products. Visit the Training section of the Raymarine website for more information:

- <http://www.raymarine.co.uk/view/?id=2372>

Technical support forum

You can use the Technical support forum to ask a technical question about a Raymarine product or to find out how other customers are using their Raymarine equipment. The resource is regularly updated with contributions from Raymarine customers and staff:

- <http://forum.raymarine.com>

Chapter 8: Technical specification

Chapter contents

- [8.1 Element technical specification on page 76](#)
- [8.2 HyperVision™ technical specification on page 77](#)
- [8.3 Internal GNSS \(GPS / GLONASS\) receiver specification on page 78](#)
- [8.4 Conformance specification on page 79](#)

8.1 Element technical specification

Power

	Element™ 7	Element™ 9	Element™ 12
Nominal supply voltage:	12 V dc		
Operating voltage range:	8 V dc to 16 V dc (protected up to 32 V dc)		
Fuse requirements:	<ul style="list-style-type: none"> • Inline fuse = 5 Amp, or • Thermal breaker = 3 Amp 		
NMEA 2000 LEN (Load Equivalency Number):	1		

Environmental

	Element™ 7	Element™ 9	Element™ 12
Operating temperature range:	-25°C (-13°F) to +55°C (+131°F)		
Storage temperature range:	-30°C (-22°F) to +70°C (+158°F)		
Humidity:	up to 93% @ 40°C (+104°F)		
Water ingress protection:	IPx6 and IPx7		
Weight (display only):	1.0 Kg	1.3 Kg	2.0 Kg

LCD specification

	Element™ 7	Element™ 9	Element™ 12
Size (diagonal):	7.0"	9.0"	12.1"
Type	TN (Twisted Nematic)		IPS (In-Plane Switching)
Color depth:	24 bit		
Resolution:	WVGA 800 x 480		WXGA 1280 x 800
Ratio	5:3		8:5
Maximum Illumination:	1500 nits / 1500 cd/m ²		
Viewing angle (T / B / L / R):	50° / 60° / 70° / 70°	50° / 70° / 70° / 70°	89° / 89° / 89° / 89°

Data connections

	Element™ 7	Element™ 9	Element™ 12
Transducer:	1 x 15-pin HyperVision™ connector.		
SeaTalkng® / NMEA 2000	1 x DeviceNet female connector built into power cable		
2.4 GHz Wi-Fi:	1 x 802.11/b/g/n		

Storage

	Element™ 7	Element™ 9	Element™ 12
External:	1 x MicroSDXC card slot		

8.2 HyperVision™ technical specification

The following specification only applies to HyperVision™ products.

Power	<ul style="list-style-type: none"> • 1.2 MHz (Hyper) = 1000 W • 350 kHz (Standard) = 700 W • 200 kHz (Conical high CHIRP sonar) = 100 W
Frequencies	<ul style="list-style-type: none"> • 1.2 MHz CHIRP • 350 kHz CHIRP • 200 kHz CHIRP
Channels	<ul style="list-style-type: none"> • Conical high CHIRP sonar • RealVision™ 3D (Hyper) • RealVision™ 3D (Standard) • SideVision™ (Hyper) • SideVision™ (Standard) • DownVision™ (Hyper) • DownVision™ (Standard)
200 kHz range	<ul style="list-style-type: none"> • Conical high CHIRP sonar = 0.6 M (2 ft) to 274 m (900 ft)
350 kHz (Standard) range	<ul style="list-style-type: none"> • RealVision™ 3D = 0.6 M (2 ft) to 91 m (300 ft) • SideVision™ = 0.6 M (2 ft) to 91 m (300 ft) each side • DownVision™ = 0.6 M (2 ft) to 183 m (600 ft)
1.2 MHz (Hyper) range	<ul style="list-style-type: none"> • RealVision™ 3D = 0.6 M (2 ft) to 38 m (125 ft) • SideVision™ = 0.6 M (2 ft) to 38 m (125 ft) each side • DownVision™ = 0.6 M (2 ft) to 38 m (125 ft)

8.3 Internal GNSS (GPS / GLONASS) receiver specification

Channels	Multiple — ability to simultaneously track up to 28 satellites
Cold start	<2 minutes
Receiver IC Sensitivity	<ul style="list-style-type: none"> • 165 dBm (Tracking) • 160 dBm (Acquisition) • 148 dBm (Cold start)
GNSS compatibility	<ul style="list-style-type: none"> • GPS • GLONASS • Beidou* • Galileo*
SBAS compatibility	<ul style="list-style-type: none"> • EGNOS • GAGAN • MSAS • QZSS • WAAS
Operating frequency	1574 MHz to 1605 MHz
Signal Acquisition	Automatic
Almanac Update	Automatic
Geodetic Datum	WGS-84 (alternatives can be selected on the MFD)
Antenna	<ul style="list-style-type: none"> • Internal — Ceramic chip mounted near top of unit
Position Accuracy	<ul style="list-style-type: none"> • Without SBAS: <= 15 metres 95% of the time • With SBAS: <= 5 metres 95% of the time

Note:

* May be supported in future software update.

8.4 Conformance specification

The display conforms to the following specifications:

- EN 60945:2002
- EMC Directive 2014/30/EU
- Australia and New Zealand C-Tick compliance level 2
- Canadian RSS 247
- FCC rules part 15

Chapter 9: Spares and accessories

Chapter contents

- [9.1 Spares on page 82](#)
- [9.2 Element accessories on page 83](#)
- [9.3 Compatible transducers - Element HV displays on page 84](#)
- [9.4 Compatible transducers - Element S displays on page 86](#)
- [9.5 SeaTalkng[®] cables and accessories on page 87](#)

9.1 Spares

Part number	Description
R70523	Power / NMEA 2000 cable (includes 1.5 m (4.92 ft) power lead and 0.5 m (1.64 ft) NMEA 2000 lead).
R70647	Element 7" trunnion kit
R70648	Element 9" trunnion kit
R70649	Element 12" trunnion kit
R70727	Element 7" suncover
R70728	Element 9" suncover
R70729	Element 12" suncover
A80553	Element 7" surface mount kit
A80554	Element 9" surface mount kit
A80555	Element 12" surface mount kit

9.2 Element accessories

Part number	Description
A80562	HyperVision™ transducer extension cable 4 m (13.12 ft)
A80559	CPT-S/DownVision 9-pin adaptor cable.
A80558	Dragonfly® 10-pin adaptor cable.
A80605	'Y' adapter cable for connecting split pair HV-300THP-P and HV-300THP-S thru-hull transducers.
A80560	MinnKota Embedded, 83 kHz / 200 kHz transducer.
A80606	MotorGuide Embedded, 83 kHz / 200 kHz transducer
E70096	EV-1 heading sensor
E70227	ECl-100 engine gateway

9.3 Compatible transducers - Element HV displays

HyperVision™ transducers

The following HyperVision™ transducers can be connected to Element™ HV displays:

Part number	Description
A80603	HV-100 — HyperVision™ Transom mount, Plastic transducer (direct connection).
A80604	HV-300TH — HyperVision™ All-in-one, Thru-hull, Plastic transducer (direct connection).
T70448	HV-300THP — HyperVision™ Pair, Thru-hull, Plastic transducers (direct connection using supplied cables).
R70725	HV-300THP-P Split, Port side, Thru-hull, Plastic transducer (Requires ‘Y’ cable (A80605) to connect split pair transducers, and extension cable (A80562) to connect to display).
R70726	HV-300THP-S Split, Starboard side, Thru-hull, Plastic transducer (Requires ‘Y’ cable (A80605) to connect split pair transducers, and extension cable (A80562) to connect to display).

Third party transducers

The third party transducers listed below can be connected to Element™ HV using adaptor cables.

Adaptor cable	Transducer
A80560	MinnKota Embedded, 83 kHz /200 kHz transducer.
A80606	MotorGuide Embedded, 83 kHz / 200 kHz transducer.

Note:
When using third party transducers only the 200 kHz channel will be available.

Compatible legacy transducers

DownVision™ transducers

The following DownVision™ transducers can be connected to Element™ HV displays using the CPT-S / DownVision 9–pin adaptor cable (A80559):

Part number	Description
A80507	CPT-90 DVS — DownVision™, Transom mount, Plastic transducer.
A80351	CPT-100 DVS — DownVision™, Transom mount, Plastic transducer. Replaced A80270.
A80277	CPT-110 — DownVision™, Thru-hull, Plastic transducer with fairing block.
A80350	CPT-120 — DownVision™, Thru-hull, Bronze transducer with fairing block. Replaced A80271.

Dragonfly® transducers

The following Dragonfly® transducers can be connected to Element™ HV displays using the Dragonfly 10–pin adaptor cable (A80558):

Part number	Description
R70374	CPT-DVS — DownVision™, Transom mount, Plastic transducer.
A80278	CPT-70 — DownVision™, Thru-hull, Plastic transducer with fairing block.
A80349	CPT-80 — DownVision™, Thru-hull, Bronze transducer with fairing block.

High CHIRP sonar transducers

The following conical beam, high CHIRP sonar transducers can be connected to Element™ HV displays using the CPT-S/DownVision 9-pin adaptor cable (A80559):

Part number	Description
E70342	CPT-S High CHIRP, Transom mount, Plastic transducer.
E70339	CPT-S High CHIRP, 0° angled element, Flush mount, Thru-hull, Plastic transducer.
A80448	CPT-S High CHIRP, 12° angled element, Flush mount, Thru-hull, Plastic transducer.
A80447	CPT-S High CHIRP, 20° angled element, Flush mount, Thru-hull, Plastic transducer.
A80446	CPT-S High CHIRP, 0° angled element, Flush mount, Thru-hull, Bronze transducer.
E70340	CPT-S High CHIRP, 12° angled element, Flush mount, Thru-hull, Bronze transducer.
E70341	CPT-S High CHIRP, 20° angled element, Flush mount, Thru-hull, Bronze transducer.

Legacy transducer extension cables

When connecting a compatible legacy transducer to an Element display, using an adaptor cable: if the cable run requires extending, you must use an extension cable which is compatible with your transducer.

Important: The HyperVision™ extension cable cannot be used to extend the cable run of legacy transducers.	
Legacy transducer	Compatible extension cable
Dragonfly® transducers	A80312 — 4 m (13.1 ft) Dragonfly® transducer extension cable. Note: Power supply wires should be isolated and protected from shorting or water ingress.
DownVision™ transducers	E66074 — 3 m (9.84 ft) DownVision™ transducer extension cable.
High CHIRP sonar transducers	A80273 — 4 m (13.1 ft) CPT-S transducer extension cable.

9.4 Compatible transducers - Element S displays

High CHIRP sonar transducers

The following conical beam, high CHIRP sonar transducers can be connected to Element™ S displays:

Part number	Description
E70342	CPT-S High CHIRP, Transom mount, Plastic transducer.
E70339	CPT-S High CHIRP, 0° angled element, Flush mount, Thru-hull, Plastic transducer.
A80448	CPT-S High CHIRP, 12° angled element, Flush mount, Thru-hull, Plastic transducer.
A80447	CPT-S High CHIRP, 20° angled element, Flush mount, Thru-hull, Plastic transducer.
A80446	CPT-S High CHIRP, 0° angled element, Flush mount, Thru-hull, Bronze transducer.
E70340	CPT-S High CHIRP, 12° angled element, Flush mount, Thru-hull, Bronze transducer.
E70341	CPT-S High CHIRP, 20° angled element, Flush mount, Thru-hull, Bronze transducer.

9.5 SeaTalkng® cables and accessories

SeaTalkng® cables and accessories for use with compatible products.

Part No	Description	Notes
T70134	Starter kit	Includes: <ul style="list-style-type: none"> • 1 x 5 Way connector (A06064) • 2 x Backbone terminator (A06031) • 1 x 3 m (9.8 ft) spur cable (A06040) • 1 x Power cable (A06049)
A25062	Backbone Kit	Includes: <ul style="list-style-type: none"> • 2 x 5 m (16.4 ft) Backbone cable (A06036) • 1 x 20 m (65.6 ft) Backbone cable (A06037) • 4 x T-piece (A06028) • 2 x Backbone terminator (A06031) • 1 x Power cable (A06049)
A06038	Spur cable 0.4 m (1.3 ft)	
A06039	Spur cable 1 m (3.3 ft)	
A06040	Spur cable 3 m (9.8 ft)	
A06041	Spur cable 5 m (16.4 ft)	
A06042	Elbow spur cable 0.4 m (1.3 ft)	
A06033	Backbone cable 0.4 m (1.3 ft)	
A06034	Backbone cable 1 m (3.3 ft)	
A06035	Backbone cable 3 m (9.8 ft)	
A06036	Backbone cable 5 m (16.4 ft)	
A06068	Backbone cable 9 m (29.5 ft)	
A06037	Backbone cable 20 m (65.6 ft)	
A06043	SeaTalkng® to bare wire spur cable 1 m (3.3 ft)	
A06044	SeaTalkng® to bare wire spur cable 3 m (9.8 ft)	
A06049	Power cable 1 m (3.3 ft)	
A06077	Right angled connector	90° right angle spur connector.
A06031	Terminator	
A06028	T-piece	Provides 1 x spur connection
A06064	5-way connector block	Provides 3 x spur connections
A06030	Backbone extender	
E22158	SeaTalk to SeaTalkng® converter kit	Allows the connection of SeaTalk devices to a SeaTalkng® system.
A80001	Inline terminator	Provides direct connection of a spur cable to the end of a backbone cable. No T-piece required.
A06032	Spur blanking plug	
R12112	ACU / SPX SeaTalkng® spur cable 0.3 m (1.0 ft)	Connects an SPX course computer or an ACU to a SeaTalkng® backbone.
A06047	SeaTalk (3 pin) to SeaTalkng® adaptor cable 0.4 m (1.3 ft)	

Part No	Description	Notes
A22164	SeaTalk to SeaTalkng [®] spur cable 1 m (3.3 ft)	
A06048	SeaTalk2 (5 pin) to SeaTalkng [®] adaptor cable 0.4 m (1.3 ft)	
A06045	SeaTalkng [®] to DeviceNet (Female) adaptor cable 0.4 m (1.3 ft)	Allows the connection of NMEA 2000 devices to a SeaTalkng [®] system.
A06075	SeaTalkng [®] to DeviceNet (Female) adaptor cable 1 m (3.3 ft)	Allows the connection of NMEA 2000 devices to a SeaTalkng [®] system.
A06046	SeaTalkng [®] to DeviceNet (Male) adaptor cable 1.5 m (4.92 ft)	Allows the connection of NMEA 2000 devices to a SeaTalkng [®] system.
A06076	SeaTalkng [®] to DeviceNet (Male) adaptor cable 1 m (3.3 ft)	Allows the connection of NMEA 2000 devices to a SeaTalkng [®] system.
A06078	SeaTalkng [®] to DeviceNet (Male) adaptor cable 0.1 m (0.33 ft)	Allows the connection of NMEA 2000 devices to a SeaTalkng [®] system.
E05026	DeviceNet (Female) to bare wires adaptor cable (0.4 m (1.3 ft)	Allows the connection of NMEA 2000 devices to a SeaTalkng [®] system.
E05027	DeviceNet (Male) to bare wires adaptor cable (0.4 m (1.3 ft)	Allows the connection of NMEA 2000 devices to a SeaTalkng [®] system.

Appendix A NMEA 2000 PGNs

PGN	Description	Transmit (Tx) / Receive (Rx)
59392	ISO Acknowledgement	Tx / Rx
59904	ISO Request	Tx / Rx
60160	ISO Transport Protocol, Data Transfer	Rx
60416	ISO Transport Protocol, Connection Management – BAM group function	Rx
60928	ISO Address Claim	Tx / Rx
65240	ISO Commanded Address	Rx
126208	NMEA - Group Function	Tx / Rx
126464	PGN Lists	Tx / Rx
(1)126992	System Time	Tx / Rx
126993	Heartbeat	Tx / Rx
126996	Product Information	Tx / Rx
126998	Configuration Information	Tx / Rx
127237	Heading / track Control	Rx
127245	Rudder	Rx
127250	Vessel Heading	Rx
127251	Rate of Turn	Rx
127258	Magnetic Variation	Tx
127488	Engine Parameters, Rapid Update	Rx
127489	Engine Parameters, Dynamic	Rx
127493	Transmission Parameters, Dynamic	Rx
127496	Trip Fuel Consumption, Vessel	Rx
127497	Trip Fuel Consumption, Engine	Rx
127498	Engine Parameters, Static	Rx
127503	AC Input Status – DEPRECATED	Rx
127504	AC Output Status – DEPRECATED	Rx
127505	Fluid Level	Rx
127506	DC Detailed Status	Rx
127507	Charger Status – DEPRECATED	Rx
127508	Battery Status	Rx
127509	Inverter Status – DEPRECATED	Rx
128259	Speed Water Referenced	Rx
128267	Water Depth	Rx
(1)129026	COG & SOG, Rapid Update	Tx / Rx
(1)129029	GNSS Position Data	Tx / Rx
(1)129033	Local Time Offset	Tx
129038	AIS Class A Position Report	Rx
129039	AIS Class B Position Report	Rx
129040	AIS Class B Extended Position Report	Rx
129041	AIS Aids To Navigation (AtoN) Report	Rx
(1)129044	Datum	Tx / Rx
129283	Cross Track Error	Tx / Rx

PGN	Description	Transmit (Tx) / Receive (Rx)
129284	Navigation Data	Tx / Rx
129285	Navigation — Route / WP information	Tx / Rx
129291	Set & Drift, Rapid Update	Tx / Rx
129301	Time to / from Mark	Rx
(1)129539	GNSS DOPs	Tx / Rx
(1)129540	GNSS Sats in View	Tx / Rx
(1)129542	GNSS Pseudorange Noise Statistics	Tx / Rx
(1)129547	GNSS Pseudorange Error Statistics	Tx / Rx
129793	AIS UTC and Date Report	Rx
129794	AIS Class A Static and Voyage Related Data	Rx
129798	AIS SAR Aircraft Position Report	Rx
129801	AIS Addressed Safety Related Message	Rx
129802	AIS Safety Related Broadcast Message	Rx
129809	AIS Class B “CS” Static Data Report, Part A	Rx
129810	AIS Class B “CS” Static Data Report, Part B	Rx
130064	Route and WP Service — Database List	Tx / Rx
130070	Route and WP Service — WP Comment	Tx / Rx
130072	Route and WP Service — Database Comment	Tx / Rx
130074	Route and WP Service — WP List — WP Name & Position	Tx / Rx
130306	Wind Data	Rx
130310	Environmental Parameters — DEPRECATED	Rx
130311	Environmental Parameters — DEPRECATED	Rx
130312	Temperature — DEPRECATED	Rx
130576	Trim Tab Status	Rx
130577	Direction Data	Rx

Note:

- (1) Only transmitted to DSC VHF radios when **Send GPS to VHF:** setting is enabled, from the GPS / GNSS Settings menu.

Appendix B Document change history

Document details	Changes
87360-4 Date: 06-2019 Software version: LHS: 3.9.98	<ul style="list-style-type: none">• Added Radar connection details.• Added Autopilot connection details.• Removed non-Wi-Fi SKUs.
87360-3 Date: 04-2019 Software version: LHS: 3.9.40	<ul style="list-style-type: none">• Updated to include details of 'S' variant displays and part numbers for non wi-fi enabled variant displays.• Updated to include details for expanded hardware compatibility i.e.: AIS700, iTC-5, Wind vane transducers and RS150 external GPS.• Added connections overview para 4.1.• Added dedicated grounding information.• Added document change history.
87360-2 Date: 03-2019 Software version: LHS: 3.8.66	Updated illustrations to latest standard.
87360-1 Date: 01-2019 Software version: LHS: 3.8.66	Initial release.

Index

A

Accessories	83
Additional components	21
Autopilot commands	53

C

Cable	
Protection	38
Strain relief.....	38
Cable extension	45
Cable routing.....	26, 46
Cleaning	57
Screen.....	57
Compass safe distance	26
Compatible transducers	18, 84
Conical sonar transducers.....	19–20, 85–86
Connection	
NMEA 2000	49
Power.....	39
SeaTalkng	49
Connections	
Battery	41
Distribution panel.....	40
General cabling guidance.....	38
Overview.....	36
Radar	52
Contact details.....	70

D

Data item	
Compatibility.....	21, 49
DeviceNet cables	88
Diagnostics.....	71
Dimensions	
Display	29
Surface mount	29
Trunion mount	29
Document applicability.....	16
Document history	91
Documentation	
Installation instructions	14
Mounting template.....	14
Operation instructions	14
DownVision transducers	18, 84
Dragonfly transducers	18, 84

E

Electromagnetic Compatibility.....	27
EMC, <i>See</i> Electromagnetic Compatibility	
Engine systems	
compatibility.....	21

F

Factory reset	61
Fuse rating.....	39

H

High CHIRP transducers.....	19–20, 85–86
HyperVision transducers.....	18, 84

I

Installation	
Best practice	42
Surface mounting.....	32
surface requirements.....	26
Trunion mounting	31
Ventilation.....	26
Interference	26
<i>See also</i> Compass safe distance	
Electrical	26
RF.....	28

L

Legacy transducer	
Connection	47
Legacy transducers	
DownVision.....	18, 84
Dragonfly	18, 84
Extension cables.....	19, 47, 85
High CHIRP	19, 85
LightHouse™ 3	
Tips and Tricks.....	73
Location requirements	
Wireless	27

M

Maintenance.....	56–57
Mounting options	30

N

N2K PGNs.....	89
NMEA 2000	
PGN support	89

O

Operation instructions, LightHouse Sport	14
Optional products.....	21

P

Pairing	
Quantum radar.....	52
PGN	89
Power	
Battery connection.....	41
Distribution	40
Distribution panel.....	40
Fuse and breaker ratings.....	39
Grounding.....	42
Sharing a breaker	40
Power cable extension	42

Power connection	39
Power troubleshooting	61
Product care	57
Product dimensions.....	29
Product information.....	71
Product overview.....	17
Product recycling (WEEE)	11
Product support.....	70

R

Radio Frequency (RF) interference.....	28
Recovery mode	61
Routine checks.....	57

S

SeaTalkng	
System example	50
SeaTalkng cables	87
Service and maintenance	56
Service Center.....	70
Servicing.....	56
Software version.....	14
Sonar transducers	
High CHIRP	20, 86
Support forum	73

T

Tank sensors	
compatibility.....	22
Technical specification	75
Technical Specification	
HyperVision Sonar.....	77
Technical support.....	70, 73
Thermal breaker rating.....	39
Third party transducers	18, 84
Training courses	73
Troubleshooting	60
GNSS (GPS).....	63
Wi-Fi.....	66

V

Video Gallery.....	73
--------------------	----

W

Warranty	70
WEEE Directive.....	11
Wireless	
Interference	27



Raymarine

Marine House, Cartwright Drive, Fareham, Hampshire.
PO15 5RJ. United Kingdom.

Tel: +44 (0)1329 246 700

www.raymarine.com

Raymarine®

a brand by  **FLIR®**