



## SP-120 Autopilot



### *INSTALLATION AND SERVICE*

*Software Version P-33*

[www.si-tex.com](http://www.si-tex.com)

---

*BLANK PAGE*

---

# Index

<b>WARNING!</b> .....	<b>4</b>
<b>SP-120 AUTOPILOT SYSTEM</b> .....	<b>5</b>
<b>INSTALLATION OF SYSTEM COMPONENTS:</b> .....	<b>6</b>
DISPLAY UNIT .....	7
COMPASS.....	8
RUDDER FEEDBACK UNIT.....	9
GPS WIRING CONNECTIONS.....	11
HYDRAULIC REVERSING MOTOR CONNECTION.....	11
MECHANICAL REVERSING MOTOR CONNECTION .....	11
Motor Connections.....	12
SOLENOID VALVE USE .....	13
<b>INITIAL OPERATIONAL SETTINGS</b> .....	<b>14</b>
MOTOR DIRECTION – AUTOMATIC SET UP .....	14
MOTOR DIRECTION – MANUAL SET UP .....	14
SENSITIVITY .....	14
RUDDER RATIO .....	15
BACKLIGHTING.....	15
SET RUDDER LIMITS.....	14
COMPASS HEADING.....	15
COMPASS CALIBRATION.....	15
COMPASS ALIGNMENT.....	15
TECHNICAL ADJUSTMENTS.....	15
Adjusting the PID Control .....	17
SP-120 DEFAULT SETTINGS: .....	18
SET UP OF THE GPS UNIT.....	19
SP-120 ALARMS.....	19
Off Course Alarm .....	19
GPS Alarm .....	19
<b>DEFINITION OF TERMS</b> .....	<b>19</b>
<b>OVERVIEW OF OPERATION</b> .....	<b>20</b>
<b>TROUBLE SHOOTING</b> .....	<b>21</b>
<b>SCHEMATIC DIAGRAM</b> .....	<b>22</b>
<b>WARRANTY</b> .....	<b>24</b>
<b>ADDITIONAL INFORMATION</b> .....	<b>24</b>

---

***Warning!***

- **THE AUTOPILOT IS A NAVIGATIONAL AID; AN ADEQUATE WATCH MUST BE MAINTAINED AT ALL TIMES WHEN AUTOPILOT IS IN USE.**
- **THE AUTOPILOT MUST BE PLACED IN MANUAL MODE WHEN THE VESSEL IS STATIONARY AS THE SYSTEM WILL CONTINUE TO DRIVE THE RUDDER TO THE END OF ITS TRAVEL AND DAMAGE TO THE SYSTEM CAN.**
- **IT IS STRONGLY RECOMMENDED THAT THE AUTOPILOT NOT BE USED WHILE NAVIGATING IN RESTRICTED WATERWAYS AS WATER CURRENTS, WIND CHANGES OR RADIO TRANSMITTER INTERFERENCE CAN ENDANGER YOUR OWN OR OTHER VESSELS.**
- **IF A GPS IS CONNECTED TO THE SYSTEM, THE AUTO MODE WILL NOT ENGAGE BELOW A SPEED OF ONE KNOT AND WILL DISENGAGE FROM AUTO WHEN THE VESSEL SLOWS TO ONE KNOT.**

---

## ***SP-120 Autopilot System***

The SP-120 autopilot control system comprises the following units:

- SP-120 display and control head.
- SI-TEX 9 Axis rate compass
- Rudder Feedback Unit (SP-120R only).

In addition the SP-120 has to be connected to a drive unit which controls the rudder actuator system in order to complete the full autopilot system. The actuator system provides the physical movement to the rudder responding to the direction of control signals provided by the SP-120. A rudder actuator system comprises one of the following:

- Hydraulic system with helm pump and ram
- Mechanical steering system

The autopilot should be connected to one of the following:

- Reversing motor / pump set connected into the existing hydraulic steering system
- Reversing mechanical drive unit connected to the existing steering mechanism
- Electronic Hydraulic Solenoid Valves

### **Block Diagram of Full System**

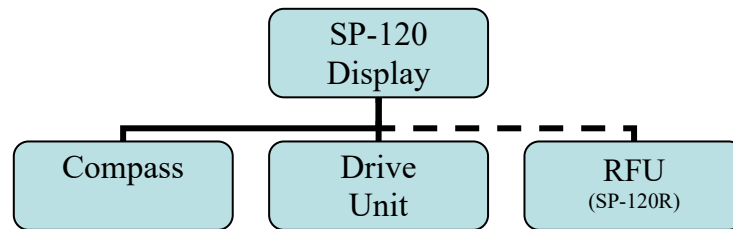

*Note: Dashed line (RFU) only applicable for SP-120R.*

The SP-120 display provides full control of the autopilot system and indicates different modes for heading, course to steer and rudder angle.

The system requires a supply voltage of **12 Volts DC**.

---

## ***Installation of System Components:***

Ensure you have all the components of the autopilot.

Tools required:

- Screwdrivers – flat blade and Philips
- Side cutting pliers
- Wire strippers
- Spanners (various) or adjustable spanner
- 70mm hole saw
- Power drill + assortment of drill bits
- Multi meter (DVM)
- Ancillaries such as tape, connecting block, screws, cable ties, etc.

Access for wiring must be provided. Cables have to be run to the power switchboard, display, compass, rudder feedback (if fitted) and drive unit.

All wiring should be kept as far as possible from radio aerials and aerial cables to prevent interference to the radio and to prevent transmitted signals from the radio influencing the SP-120. As no steel is used in the SP-120 display, there is negligible effect on a steering compass.

The compass must be mounted a minimum distance of 1 metre from any boat compass, radios, speakers or other products with magnetic properties to avoid interference.

The SP-120 must have a direct connection to power supply via a 15 amp circuit breaker or a 15 amp fused circuit and an isolating switch.

---

## Display Unit

### Position:

The SP-120 Head unit should be mounted in a position accessible to the steering position and protected from direct rain or salt water

- Select a dry position
- For in dash mounting cut a 70mm (2.5”) hole (an optional mounting bracket is available and may be used for display mounting – see your supplier)
- Drill mounting screw holes
- Mount the display using screws supplied (304 SS – 6G)
- Fit dome plugs to cover screws
- Ensure motor (yellow) and clutch (green) wires are not touching together before connecting power to the SP-120
- Connect red wire to + 12 volts DC
- Connect black wire to – 12 volts DC

### SP-120 Display (Rear) Wiring Diagram:



---

## Compass

Take care when handling the compass as it is a sensitive piece of equipment. The compass position is the most important item in the installation of the autopilot. Good course holding is dependent on the compass being free from magnetic interference and excessive rolling or pitching.

### Position:

- Select a dry position free from magnetic interference. (Check other side of bulkheads for magnetic objects)
- Avoid locations near radios, speakers, antenna cables, wiring harnesses, or electric motors (ie: bilge pumps, winches, etc.)
- Mount the compass horizontally with the arrow (bow) pointing in the same direction as the boat's bow. Compass cannot be mounted upside down! Use non-magnetic screws (304 grade stainless steel)
- Run cable to SP-120 display position (keep away from other cables)
- Connect compass cable to SP-120 compass socket.

### Compass Mounting:

Arrow on Compass oriented toward Vessels Bow.  
**Do Not Mount the Compass Upside Down!**



Mounting Screw  
covers open



---

## ***Rudder Feedback Unit***

*Note: Only for SP-120R version.*

The SP-120R Autopilot is supplied with an RFU (rudder feedback unit), which provides to the pilot a precise position of the boat rudder.

### **Position:**

- Refer diagram on page 8
- Mount rudder feedback adjacent to the tiller (rudder feedback movement must copy the angular movement of the tiller). Use mounting bracket if required
- Note markings on the rudder feedback unit. P & S indicate the required movement of the tiller for course correction
- Rudder feedback is mounted with shaft uppermost
- Fit snap lock swivel joint to rudder feedback arm
  
- Fit link block to tiller arm
- Fit link arm from rudder feedback to tiller – adjust for correct angle
- Route cable to SP-120 display position
- Connect rudder feedback cable to SP-120 rudder socket
- When installation is complete, slowly move the steering by hand to ensure:
  - a) The direction indicated on the top of the RFU is correct
  - b) No undue mechanical strain is placed on the feedback or linkage

### *Notes:*

- 1 The rudder feedback unit is water resistant. However, if it is to be mounted in a wet position, some protection should be provided to ensure the unit does not become excessively exposed to water or submerged in water.*
- 2 The rudder feedback unit may be mounted upside down, in which case the blue and red wires in the cable must be reversed (yellow wire in cable is not used in the feedback).*

## Rudder Feedback Installation Diagram

Note: Pin locations are relative to pin 1 which always has a dot adjacent.

Note: The rudder feedback is factory aligned.  
The arm should not be removed or loosened the shaft as this will affect the "O" ring seal.

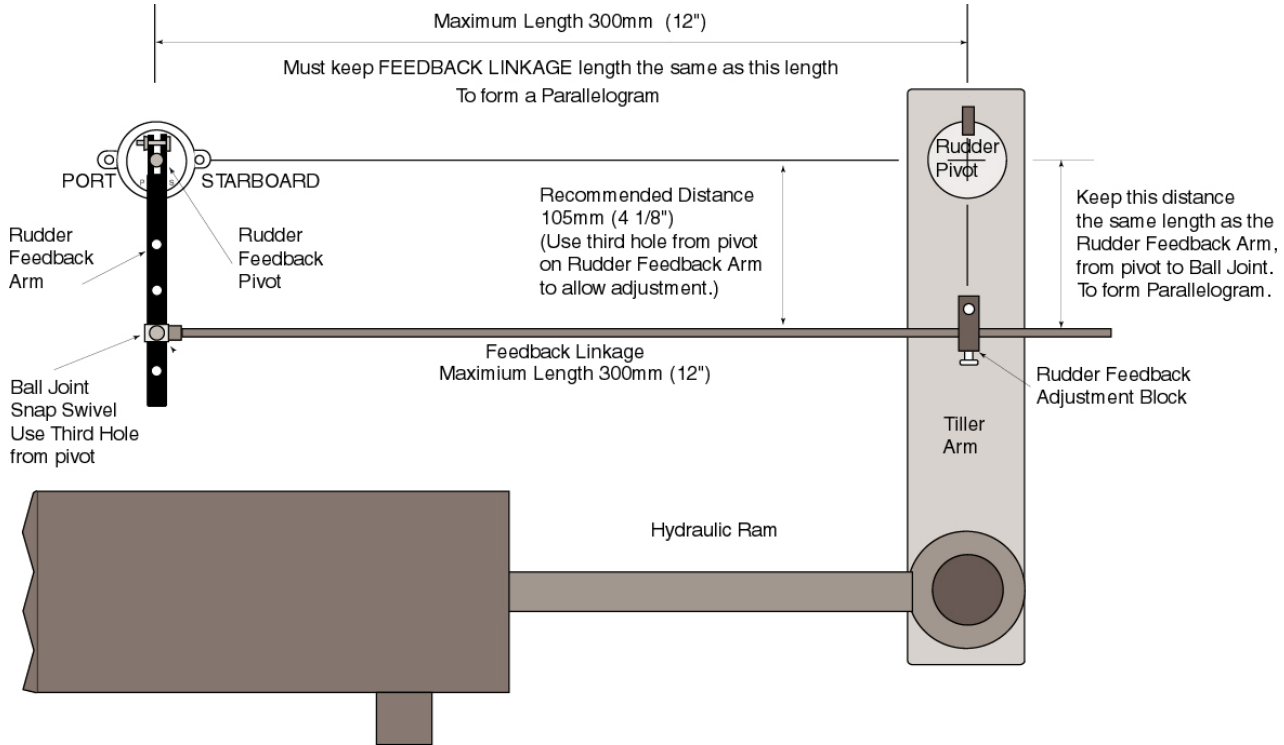

## Octopus Mechanical Drive RFU Connections

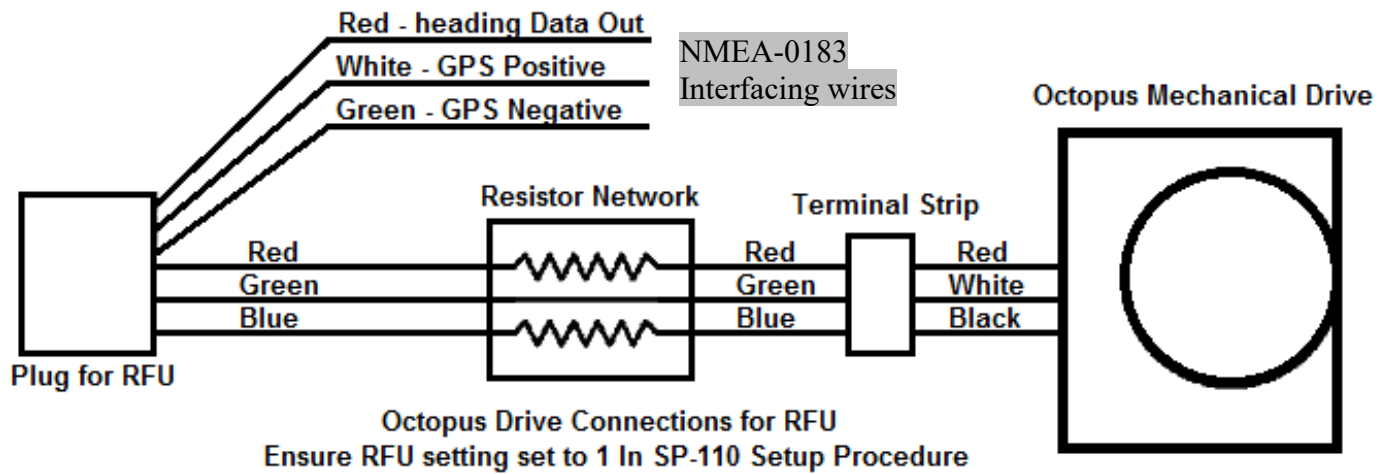

---

## Rudder Feedback / GPS Wiring Diagrams

Pin connections from rear of plug, solder connection side. Pin 1 has adjacent dot.

Pin 1	5 V Rudder Feedback Supply
Pin 2	Rudder Feedback Wiper Return
Pin 3	0 V Rudder Feedback Supply
Pin 4	TX Data (heading information)
Pin 5	+ GPS Input (Positive)
Pin 6	- GPS Input (Negative)

*Note: Pin locations are relative to pin 1 which always has a dot adjacent.*

### ***NMEA-0183 GPS Wiring Connections***

NMEA-0183 GPS Input connections from rudder feedback plug,

Pin 5	+ GPS Input (Positive)	–	white wire
Pin 6	– GPS Input (Return)	–	green wire

For GPS navigation, connect the GPS unit via the White and Green wires coming from the back of the rudder feedback plug on the SP-120 display unit.

NMEA-0183 Heading Data out @ 10 Hz is available via the Red & Green wires from the rudder feedback plug

Pin 4	+ Heading Data Out (positive)	–	red wire
Pin 6	– Heading Data Out (return)	–	Green wire (data ground)

*Note: For information on connecting different brands of GPS units, refer to the relevant GPS manual*

### ***Hydraulic Reversing Motor Connection***

- Route suitable two conductor cable from motor to SP-120 display (recommend 12/2 wire gauge minimum)
- Connect motor cable to the yellow and yellow/black motor wires at SP-120

*Notes:*

3 *With SP-120 in MANUAL yellow motor wires are both at + 12 VDC*

4 *Yellow/black wire will give negative voltage out when port rudder movement is required.*

5 *Motor direction can be checked with SP-120 in MANUAL by pressing ◀ or ▶ once power has been connected to the SP-120*

### ***Mechanical Reversing Motor Connection***

- Route suitable four core cable (10 amp min) from motor to SP-120 display
- Connect motor wires to the yellow and yellow/black motor wires at SP-120
- Connect one clutch wire to green wire at SP-120
- Connect second clutch wire to + 12 VDC voltage supply

*Note: If a linear hydraulic drive is used, the connections are for mechanical drive.*

# Motor Connections

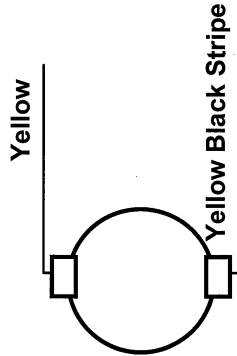

Reversing Motor Connections

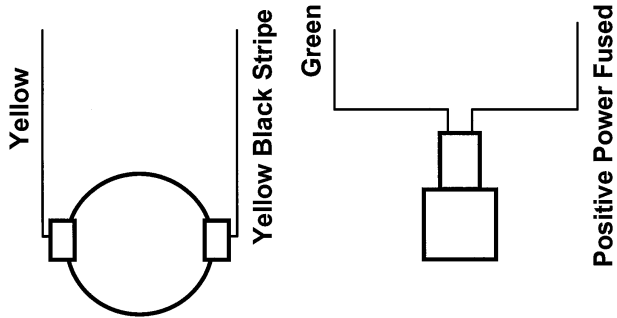

Reversing Motor and Bypass Valve Connections

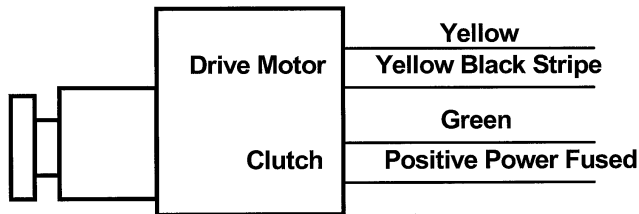

Mechanical Drive Motor

## Solenoid Valve Use

Solenoid Valve use, Wire the solenoid valves to Yellow and the 12 volt power feed and Yellow with Black stripe and 12 volt power feed on second terminal block. Ensure 12 volt is via a suitable fuse, less than 5 amps.

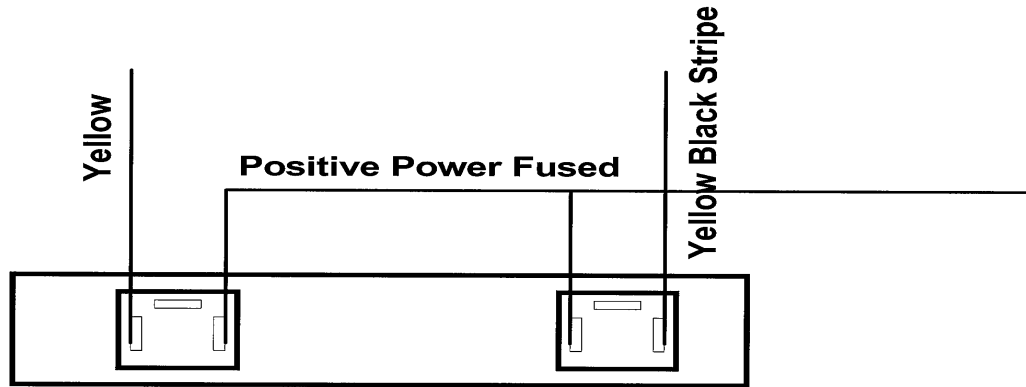

**Solenoid Valve Drawing**

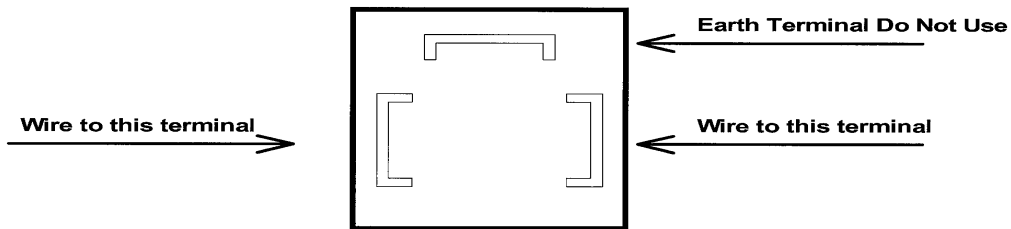

**Solenoid Valve Connections**

**Green Wire is not used**

---

## ***Initial Operational Settings***

The initial set up of the SP-120 is done once the system installation is complete and power has been connected to the SP-120 display control. The set up can be done automatically or manually

Automatic installation set up determines the output polarity for motor direction and rudder limit setting. **This method can only be used where a rudder feedback is fitted.** The installation procedure is designed to work on a rudder speed of 8 to 20 seconds hard over to hard over. The process may fail with faster or slower rudder movement in which case the manual set up should be used.

The maximum rudder travel will be set to 33° each side in the automatic set up.

*Note: If the manual set procedure is used both motor direction and rudder must be set individually.*

### ***Motor Direction – Automatic Set Up***

To commence:

- Switch power on to SP-120
- MANUAL light is lit
- Press MODE button until display shows InSt
- Press ◀ and ▶ together to start the process
- Display will show UAIt (Wait)
- Process will take between 20 and 60 seconds to complete depending on the speed of the motor
- If process is successful display will show dOnE (Done)
- Press either MODE or AUTO to cancel the installation process
- Display will show CAnC (Cancel)
- If ErrO is displayed an error has occurred
- Check the drive output is connected and rudder feedback is moving
- If FAIL is displayed the installation process has not been successful because rudder travel angle is too narrow
- Check rudder feedback installation

### ***Motor Direction – Manual Set Up***

- Switch power on to SP-120
- MANUAL light is lit
- Display indicates compass heading – example H123
- Press ◀ - rudder should move to port
- Press ▶ - rudder should move to starboard
- If direction is incorrect, reverse the yellow wires.

### ***Set Rudder Limits***

*Note: Available on the SP-120R (Rudder Feedback) versions only*

- SP-120 in MANUAL
- Press MODE until display shows PL - - (port limit)
- Turn boat helm until rudder reaches required angle – example 28° port
- Press ◀ and ▶ together to save this setting
- Press MODE again until display shows SL - - (starboard limit)
- Turn boat helm until rudder reaches required angle – example 28° stbd
- Press ◀ and ▶ together to save this setting
- Press AUTO to return to MANUAL

### ***Sensitivity***

*Note: Available on the SP-120R version only.*

Factory default setting is 04 and should only be altered during seas trials

- SP-120 in MANUAL
- Press MODE button until display shows 04
- Press ▶ to increase setting (Slower response to course corrections)
- Press ◀ to decrease setting (Quicker response to course corrections)
- Display returns to MANUAL and shows heading after 3 seconds

---

## **Rudder Ratio**

Factory default setting is 03 and should only be altered during seas trials

- SP-120 in MANUAL
- Press MODE until display shows r 03
- Press ► to increase setting (larger rudder ratio)
- Press ◀ to decrease setting (smaller rudder ratio)
- Display returns to MANUAL and shows heading after 3 seconds

*Note: A value of 1 signifies the minimum amount of applied rudder. When the rudder setting is too low, vessel track will be a slow “S”, i.e., understeer through too little rudder applied.*

*A value of 20 signifies the maximum amount of applied rudder. When the rudder setting is too high, vessel track will be a rapid “S”, i.e., oversteer through too much rudder applied.*

## **Backlighting**

When using the autopilot at night, the backlighting can be turned on.

- Press MODE four times SP-120R
- Press MODE until display shows LitE
- Press either ◀ or ► to turn the backlight on
- Press either ◀ or ► again to turn the backlight off

## **Compass Heading**

- Switch on power to SP-120
- Check display heading – example H 123
- Check this heading against a known accurate bearing
- If display reading differs from known heading \*, the compass can be calibrated.

*\* Note: Compass headings rarely agree on every heading for 360° rotation. The compass heading is set for optimum alignment only*

## **Compass Calibration**

To carry out this procedure the boat must be in open waters and be able to safely turn through 360°.

- Switch on power to SP-120
- Press MODE button until display reads CCAL
- Slowly turn boat in a circle
- Display shows dOnE when calibration is complete

## **Compass Alignment**

The compass may need to be aligned with a known heading

- Rotate compass until display reads the same the known bearing
- Re-install the screws

---

## Technical Adjustments

These procedures are used to adjust internal parameters of the SP-120.  
Each routine can be set or reset and can be displayed individually.



To enter the procedures:

- Place SP-120 in MANUAL MODE
- Press MODE key until display shows P-41 (if the firmware version is 41)
- Press ► to access the first technical parameter
- Display changes to 1- 02
- Press ◀ and ► together to adjust the first parameter
- Display changes to 1= 02
- Change the setting by pressing ◀ or ► to increase or decrease
- Press ◀ and ► together to save the new setting
- Display changes back to 1 – 03 (example if setting was increased by one)
- Press ► again to access the next parameter and continue as above

Press MODE or AUTO Keys to return SP-120 to normal operation.



---

## Parameters List:

- 1 **Pulse Length** – The minimum pulse width when the autopilot is in Virtual RFU mode. When the system is near to the desired position, the pulse of current applied to the motor will have this length.  
(This parameter is not used when in Rudder Feedback mode)
- 2 **Reverse Delay** – Sets the delay time between motor direction changes. The purpose of this parameter is avoiding high currents being drawn by the motor;
- 3 **Dead Band** – Sets the tolerance in degrees concerning the desired heading. For example, if the desired course is 90° and the dead band is 1°, the control will activate for correcting the heading when it is out of the interval from 89° to 91°;
- 4 **Maximum Rate of Turn** – It limits the rate of turn of the boat, mainly due to big changes in the desired course;
- 5 **Minimum Speed in Knots** – Set at 1 knot as the default, it gives the minimum speed acceptable for operating the autopilot in Virtual Rudder Feedback mode. Autopilot must have GPS Speed input for this function to operate.
- 6 **rF - 0:** (Virtual Rudder Feedback mode on) **rF - 1:** (Rudder Feedback mode on)
- 7 **Integral Control Gain** – Sets the integral parameter for the PID control. It is used only when in RFU mode. See the section “Adjusting the PID control” for further information.
- 8 **Derivative Control Gain** – Sets the derivative parameter for the PID control. It is used only when in RFU mode. See the section “Adjusting the PID control” below for further information.
- rEst **Master Reset** – Reset all the configurable parameters of the device to the default values. Both arrows ◀ ▶ need to be pressed together twice to activate reset. You will hear a double beep to confirm activation.
- A **BOD Correction Factor** (Bearing, origin to destination) – Sets how fast must be the correction of a BOD error. The bigger this factor, the slower (smoother) the correction.
- B Reserved;
- C **Wind Damping** – This parameter can be set ON (1) or OFF (0). When it is ON, the action of the wind on the desired course the vessel will be compensated;
- D **Power Supply Voltage** – Displays the voltage of the power supply;
- E TMQ use only;
- F **Rate of Turn Tolerance** – Sets the tolerance of control to the rate of turn. It is used for the control without RFU. The number displayed when multiplied by 10 represents the rate of turn in degrees per minute. When the vessel’s rate of turn is less than this number, it will be ignored by the control;
- G **Control calculation period** – Sets the period between two subsequent calculations for the control without RFU. For vessels which have a slow response for the control, it may be required to increase this value.

## Adjusting the PID Control

PID stands for Proportion, Integral and Derivative, which are the three calculated values that summed result in the control law value. This value is the position to where the Rudder must be driven. Below is described how each of these values contributes to the control of the vessel.

- **Proportional value:**

The bigger the error from the desired direction from the current direction of the vessel, the bigger is this value. It provides a more responsive system when the boat is too far from its desired direction.

However, this proportional value may be not enough when the vessel's direction is being disturbed by some force that takes it from its route (unbalanced load, wind ...).

In the autopilot, the gain (contribution) of this value is adjusted with the rudder ratio.

- **Integral value:**

This portion of the control value integrates the error, for compensate the forces and disturbances that the proportional control value can't cope. It is intended to provide no error on the vessel's direction result.

The adjustment of the gain for this parameter is explained in the sections “Technical Adjustments” and “Parameters List” (parameter 7) above;

- **Derivative value:**

This value is intended for providing stability to the system avoiding "hunting". It is based in the variation of the error, in this case, how fast the boat is turning. This value will be zero when the vessel is not turning, and will oppose to the turn movement when it happens.

The adjustment of the gain for this parameter is explained in the sections “Technical Adjustments” and “Parameters List” (parameter 8) above;

---

***SP-120 Default Settings:***

Default operator settings:

Rudder Ratio..... 3  
Sensitivity ..... 4 (Sensitivity only available when a Rudder Feedback is installed)

**Technical Adjustment Parameters      Default Settings**

1. Pulse Length..... 2  
2. Reverse Delay..... 15  
3. Dead Band ..... 10 (1°)  
4. Maximum Rate of Turn ..... 50 (500°/min)  
5. Minimum Speed ..... 1.0 (knot)  
6. With or without RFU..... rf – 1  
7. Integral Control Gain..... 5  
8. Derivative Control Gain ..... 3  
A BOD Correction Factor ..... 15  
B Reserved ..... 0  
C Wind damping ..... 0  
F Rate of Turn Tolerance ..... 15  
G Control Calculation Period ..... 6

---

## ***Set Up of the GPS Unit***

*Because there are a great variety of GPS units that will work with this autopilot, the following is a guide only. For more information, consult your GPS manual.*

The GPS unit must be set up to output “NMEA 0183” data on a pair of wires, which are connected to the SP-120 unit via the rudder feedback connector. The data generated must include at least one of the following:

- The APA sentence.
- The APB sentence.
- The BOD and XTE sentences.
- If only the XTE data sentence is available, the pilot can steer in a restricted manner only. (See later in this section.\*\*)

The GPS unit must be programmed and activated to navigate to a waypoint, or to follow a line joining two or more waypoints (called a route). This unit should then send information to the autopilot from which can be calculated the course-to-steer.

Under the following conditions:

- several waypoints are linked together into a single route,
- the GPS unit is set and capable of “auto-sequence” between them,
- an “arrival zone” of more than 0.05 NM (Nautical Miles) is set so that the GPS can detect when the vessel has reached a waypoint; then the SP-120 will be able to steer from each waypoint to the next without intervention.

\*\* If only the XTE information is available from your GPS unit then your vessel must be on track, and heading in the correct direction, before engaging the GPS unit. The “auto sequence” feature is not available in this instance.

*Remember: Prior to engaging GPS mode, a route or destination must be programmed and selected in the GPS for the Autopilot to follow.*

### ***SP-120 Alarms***

*A number of conditions will cause alarms to sound and an alarm message to flash on the display*

#### ***Off Course Alarm***

In AUTO mode an audible alarm of 3 “beeps” per second will sound when boat heading is greater than 45° from the desired course. The ALARM light will also flash on and off.

#### ***GPS Alarm***

In waypoint steering mode an audible alarm of 1 “beep” per second will sound when no GPS data is received by the SP-120. ALARM and GPS lights will also flash on and off.

## ***Definition of Terms***

**SP-120 Display:** The operational control unit with LCD display and push buttons.

**Heading:** This is the magnetic heading of the vessel at the current time \*.

**Course-to-steer:** The heading which the autopilot is attempting to maintain.

*\*Note: If there is no compass connected and a GPS is used as heading reference, the display shows COG (course over ground).*

## Overview of Operation

- **MANUAL Mode: “H\*\*\*”**

The autopilot display unit shows the current heading.

The boat is under **manual** steering control; **the autopilot will not apply any steering control.**

- **AUTO Mode: “A\*\*\*”**

The autopilot will maintain your vessel on the course indicated. This course can be set or altered from the display unit.

- **WAYPOINT Mode: “A\*\*\*”**

When receiving information from a GPS plotter, the autopilot can steer a vessel to a precise latitude and longitude (waypoint) or through a sequence of latitudes and longitudes (route).

- **WIND Mode: “S\*\*\*” or “P\*\*\*”**

When receiving information from a Wind Direction System, the autopilot can steer a vessel based on the wind direction. This is specially useful for sailboats.

- **JOG Mode:**

When the autopilot is in manual mode, ◀ (port) or ▶ (starboard) buttons may be pressed and the steering will be driven in the relevant direction.

## Testing Procedure

### Initial Inspection and Testing



1. Confirm power to be connected is the required DC voltage.	
2. Power Supply 12V DC is available.	
3. Ensure polarity of the voltage supply is correct.	
4. All electrical connections are correct.	
5. Loose cables are clipped or tied up.	

### Dockside Tests

1. Turn steering wheel fully clockwise and visually check that moving (mechanical) parts do not foul;	
2. Repeat step 1 for anti-clockwise.	
3. Return Steering to centre.	
4. Switch on SP-120 Autopilot system.	
5. Press arrow button to operate steering in that direction	
6. Check that rudder moves in correct direction	
7. Check Rudder direction follows change request	
8. Check Course change provides sufficient Rudder movement	
9. Check magnetic heading display on SP-120	
10. Return steering to centre	

---

## ***Trouble Shooting***

### **SP-120 Display is not displaying any heading and no light is lit.**

- Check power is available – 12VDC
- Check boat master switch for autopilot
- Check circuit breaker (if applicable)
- Check in-line fuse of SP-120 red wire
- Check all wiring connections

### **SP-120 does not move rudder when AUTO is selected**

- Confirm SP-120 display is showing heading information.
- Check voltage is present at the SP-120 motor connections (Yellow and yellow with black stripe) when AUTO is selected, and a course change applied.
- Confirm that the supply voltage is 12 volts DC (Red and Black).
- Check all motor and clutch wiring
- Check motor brushes
- Check the hydraulic system:
  1. Ensure there is enough hydraulic fluid in reservoir
  2. Hyd. Pump may be air bound, Purge the system of any air pockets / contamination.
  3. Ensure that any flow restricting valves are not completely closed.
  4. Check all connections for leaks.

### **SP-120 display shows LOSP when AUTO selected (when using GPS input)**

- Vessel must be moving forward at a minimum of 1 knot in order to engage the Autopilot when operating in Virtual Feedback Mode
- Check speed setting in parameter adjustment is set to a minimum of 1

### **SP-120 does not follow waypoint route**

- Check GPS plotter waypoint setting
- Check GPS and AUTO selected on SP-120
- Check alarm status of SP-120
- Ensure that the GPS unit has the correct magnetic correction factor.
- Check SP-120 compass alignment and possible magnetic interference

### **No GPS Data Alarm**

- Check wiring of the GPS to the SP-120 unit.
- Check sentence in GPS unit for correct data output
- Check route is set up or selected in the GPS unit
- Check location fix at the GPS unit.
- Check location fix at the GPS unit.

# Schematic Diagram

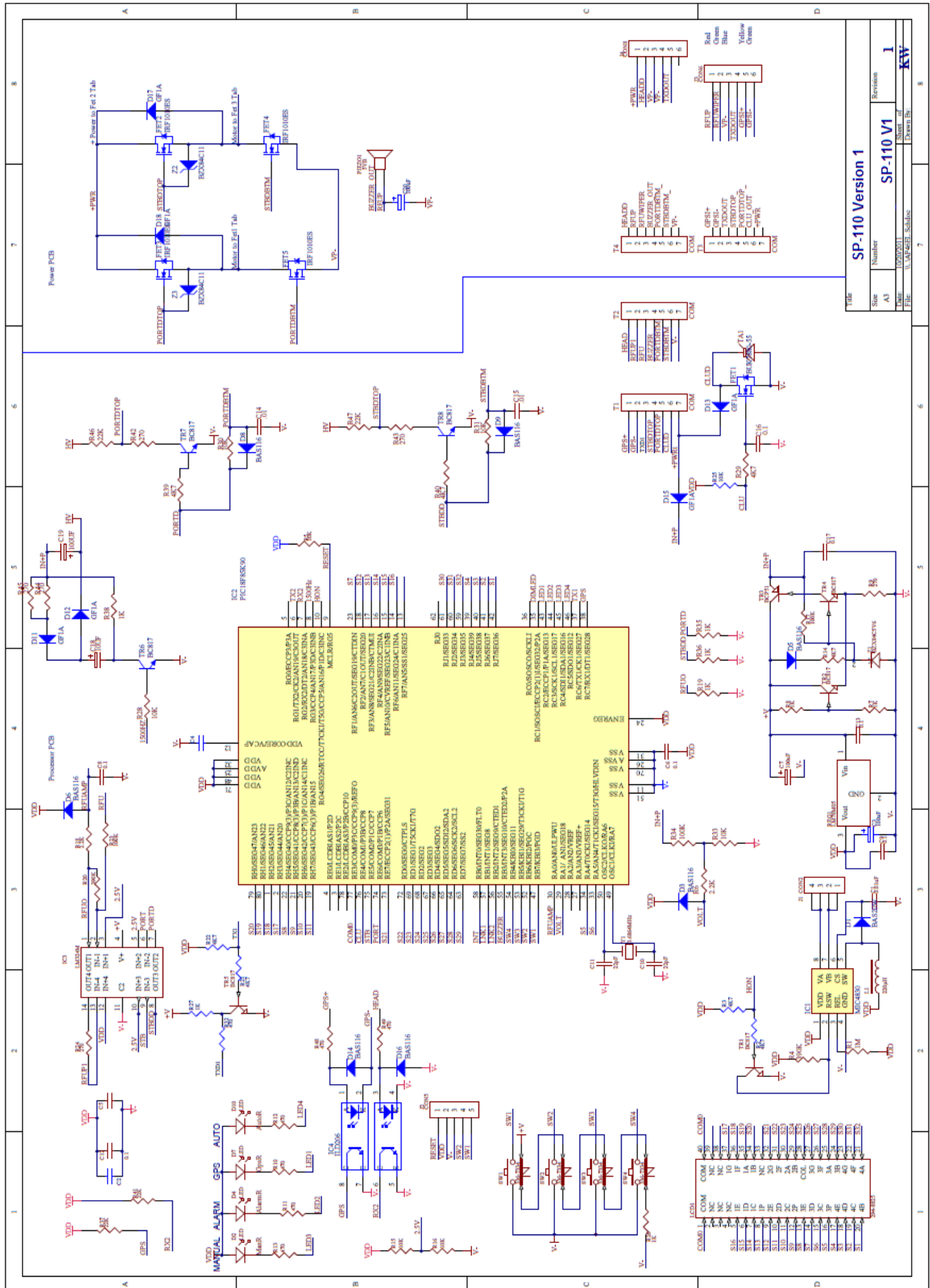

Title	SP-110 Version 1	
Size	A3	Number
DATE	10/20/2011	Revision
FILE	U:\AP449F_Schalle	Drawn By
		Sheet of
		1
		KW

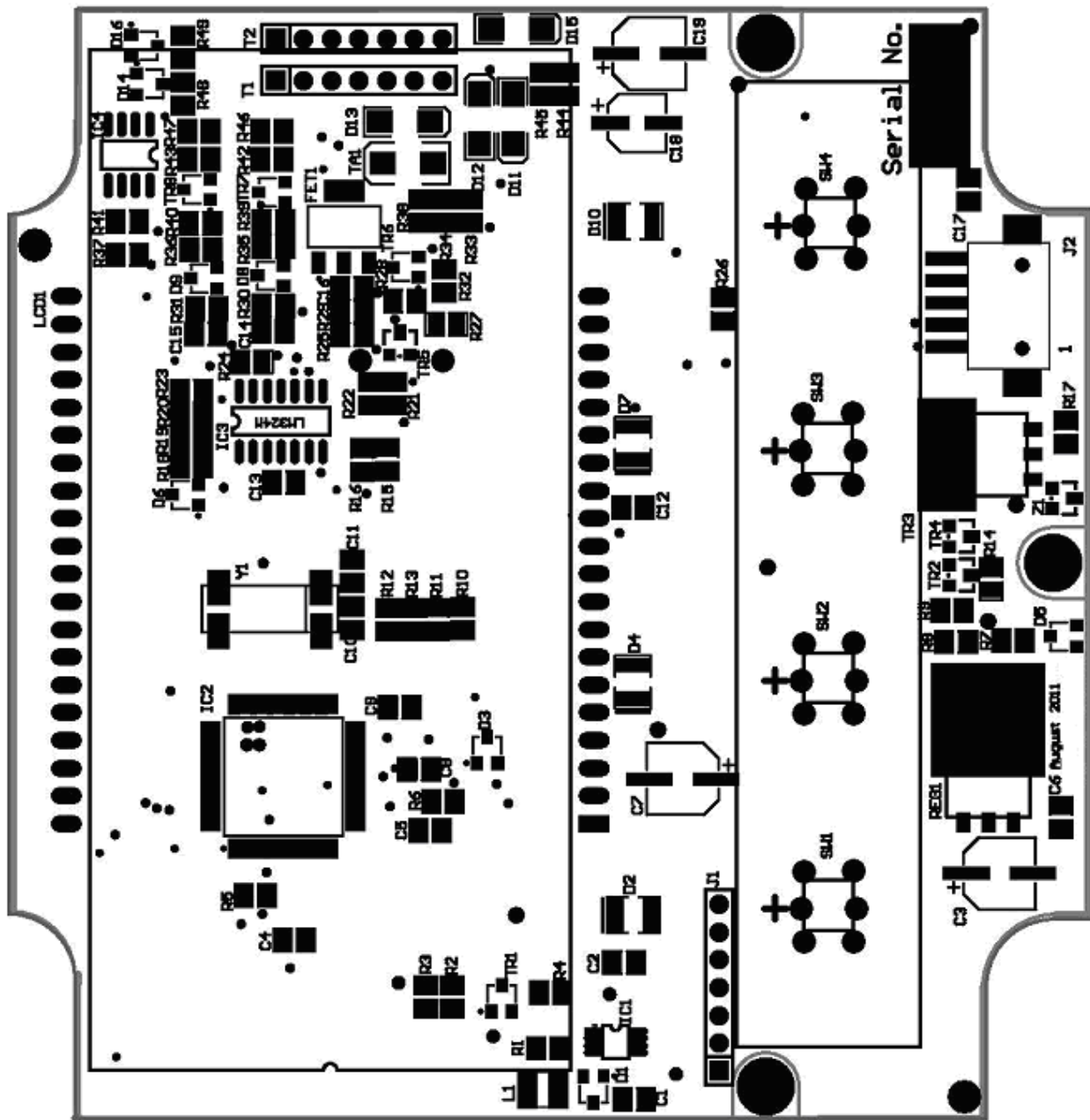
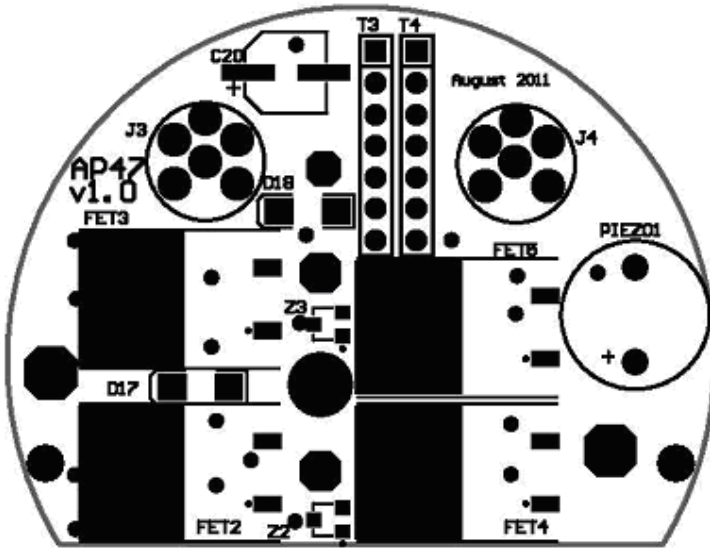

---

## ***Warranty***

SI-TEX products are thoroughly inspected and tested before shipment from the factory and are warranted being free of defects in workmanship and materials for a period of one year from the date of shipment from the factory.

This warranty is extended to and is solely for the benefit of the original consumer purchaser.

All units in need of repair will be repaired without charge to the purchaser during the above mentioned period in accordance with the following terms and conditions:

1. The defective unit is returned "freight prepaid" to **SI-TEX Marine Electronics 25 Enterprise Zone Drive, Suite #2 Riverhead, NY 11901**.
2. Proof of purchase is supplied and original Serial Numbers on equipment have not been changed.
3. Information is provided regarding the nature of the failure or problem occurring.
4. A return address is supplied to enable the equipment to be returned by road freight. Any other means of transport will be charged to the customers account and must be paid in advance.

**This warranty does not cover defects or damages caused by unauthorised service or damage through accident, misuse or abuse. The owner is also responsible for providing reasonable maintenance and weather protection of the equipment.**

**SI-TEX shall not be liable for damage or loss incurred resulting from the use and operation of this product. SI-TEX reserves the right to make changes or improvements to later models without incurring the obligation to install similar changes to equipment already supplied. Some states do not allow the exclusion or limitation of incidental or consequential damages; therefore the above limitations or exclusions may not apply to you. This warranty gives you specific legal rights and you may also have other rights, which vary from state to state.**

## ***Additional Information***

Refer to SI-TEX website





## **Customer Service**

If you encounter problems during the installation or operation of this product, or cannot find the information you need, please contact Sitex Customer Service.

The contact numbers and e-mail address for Sitex Customer Service are:

Sitex Main Office.....+1-631-996-2690

Sitex Fax.....+1-631-996-2693

Sitex Customer Support E-mail address: [customerservice@si-tex.com](mailto:customerservice@si-tex.com)

### Sitex Main Office Address:

25 Enterprise Zone Drive, Ste 2

Riverhead, NY 11901

Technical Support is available from 9:00 AM to 5:00 PM Eastern Standard Time, Monday through Friday.