

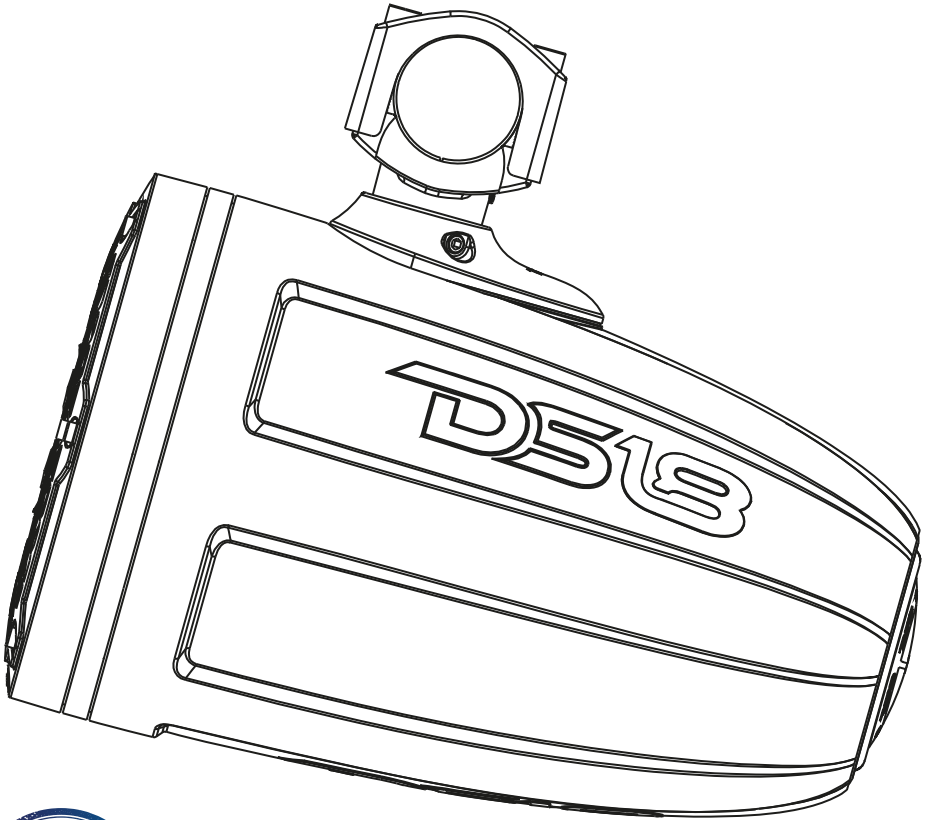

DS18[®]

HYDRO

OWNER'S MANUAL
NXL-X6TP
6.5" WAKEBOARD POD TOWER SPEAKERS



#WELIKEITLOUD     

SPECIFICATIONS

NXL-X6TP

General Specifications

Nominal Diameter.....	6.5"
Nominal Impedance.....	4 ohms
RMS Power Handling.....	100 Watts
MAX Power Handling.....	300 Watts
Sensitivity (1w/1m).....	91 dB
Frequency Response.....	65 Hz - 23 KHz
Recommended Hi Pass Crossover..	80 Hz

Body / Features

Enclosure Material.....	Injection PC+ABS (BK & RD), Injection ASA (WH)
Marine Grade Type.....	IP65 + UV Stable
RGB LED.....	Integrated RGB LED Speaker Lighting, Integrated RGB LED Acrylic Ring Lighting and RGB LED Back Logo with 6 Core Wires for Lighting and Speaker
Grill Type.....	ASA (Injection Grill)
Clamps.....	Die-Cast adjustable (1" ~ 2") 360 Degree Rotation Mounting Buried Wire or Open Wire Mounting Optional, Included NBR Pad And Stainless Hardware (Screws, Stop Washers, Hexagon wrench, Safety Rope, Screw fastening Glue)
Front/Rear Logo.....	Can be Rotated For Correct Angle Display
Finish.....	Matte Black/Gloss White/Gloss Red

Woofer Specifications

Voice Coil Diameter.....	1.2"
Cone Material.....	Waterproof Injection Polypropylene
Surround Material.....	Butyl
Basket Material.....	PC Injection Molded Composite
Magnet Material.....	Ferrite + Reverse Neodymium
Magnet Grade.....	Y35+N40H

Tweeter Specifications

Voice Coil Diameter.....	1"
Type.....	Dome PEI Surround
Diaphragm Material.....	Titanium
Magnet Material.....	Neodymium
Crossover.....	6dB/Oct

NXL-X6TP

Thiele & Small Parameters

Equivalent Volume	Vas..... 8.5 L
Excursion (one way)	Xmax..... 4 mm
Free Air Resonance	Fs..... 65 Hz
Total Factor	Qts..... 0.622

Speaker Measurements

Overall Diameter.....	6.93" / 176.1mm
Overall Depth.....	11.37" / 288.8mm
Overall Height.....	10.7" / 271.7mm

DIMENSIONS

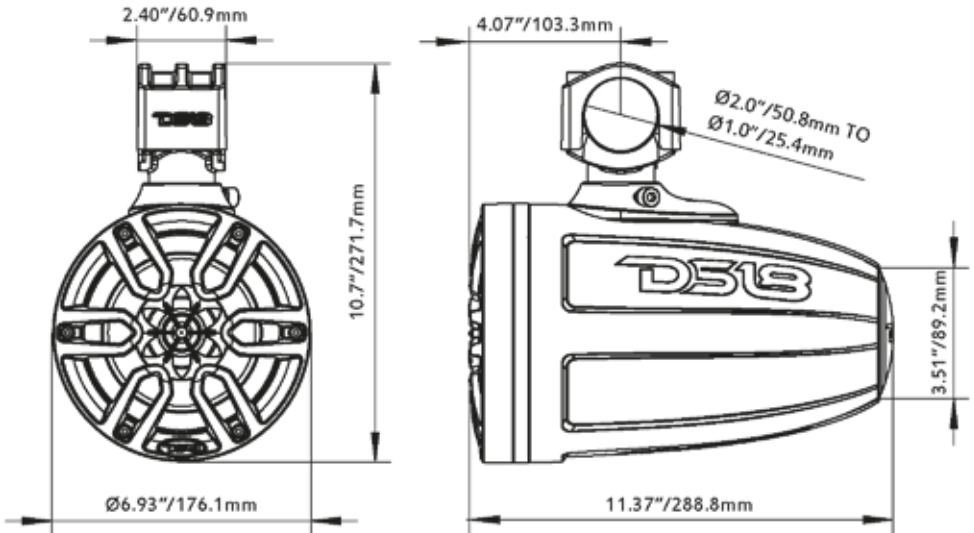

We Reserve The Right To Change Products And Specifications At Any Time Without Notice. Images May Or May Not Include Optional Equipment

READ BEFORE INSTALLATION

1. Be sure to carefully read and understand the instructions before attempting to install these speakers.
2. For safety, disconnect the negative battery terminal from the battery prior to beginning the installation.
3. For easier assembly, we suggest you have all your tools in hand- Drill, Allen set, Crimp, Soldering iron, Wire Strippers, Heat-shrink,etc.
4. Use high quality "Waterproof" connectors for a reliable installation and to minimize signal or power loss.
5. **Think before you drill!** Be careful not to cut or drill into gas tank, fuel lines, brake or hydraulic lines, vacuum lines or electrical wiring when working on any vehicle. If installing in a boat, make sure not cut or drill through the main hull.
6. Never run wires near fuel lines or power (if possible). Running the wires inside the hull or car area provides the best protection.
7. Avoid running wires over or through sharp edges. Use rubber or plastic grommets to protect any wires routed through metal, especially the tower.
8. Make sure that the mounting clamp or "L" bracket are tight before leaving the dock.
9. Decide early what type of LED lighting you want (if any) and wire accordingly
(NOTE :if you want "Dancing Light" look to the WiFi or RF or BT remote controlled LED light box.
The easy way to have lighting ... YOUR way!)

INSTALLATION EQUIPMENT

- An Electric Drill With Bits
- Allen / Hex Key / Wrench Set
- Philips Head And Standard Screw Drivers
- Wire Strippers
- Crimping Tool
- Vom (Electronic Volt Ohm Meter)
- Heat Shrink Tubing And Heat Gun
- Soldering Iron
- Electronic (Rosen Not Acid Core) solder

PACKAGING INCLUDES

- 1 Pair 6.5" Wakeboard Pod Tower Speaker
- 1 Piece 6 mm Hex wrench Chromed
- 1 Piece 4 mm Hex wrench Chromed
- 1 Pair NBR Pad For 1" to 3" tube adjust
- 1 Pair Stainless Safety Rope
- 1 Pcs Screw Fastening Glue

NOTE: The stainless steel hardware supplied with your speakers has been chosen to resist rust and corrosion. If the particular hardware supplied will not work for your installation purposes, please be sure to use only appropriate marine grade (stainless steel) mounting hardware.

▶ If you have an LED Control Module (LED-BTC), Connect as Shown in the Following Diagram:

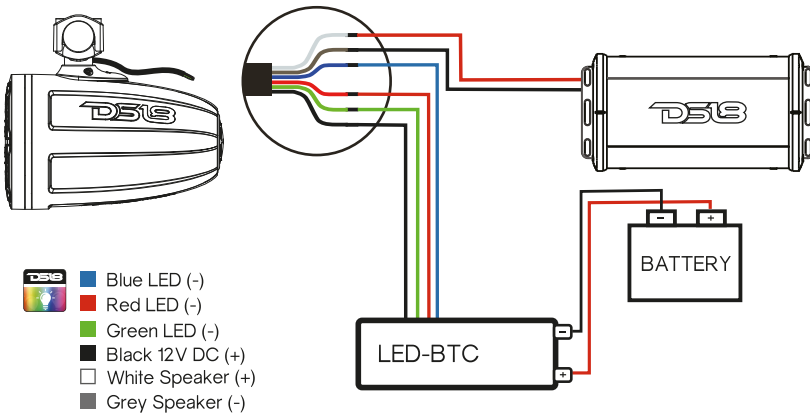

▶ To connect without LED Control Module (LED-BTC), Connect as Shown in the Following Diagram:

- Black wire "BK" Connected to Battery Positive (+) 12V
- White Color Light "R"; "B" and "G" Connected to Battery Negative (-)
- Green Color Light "G" Connected to Battery Negative (-)
- Red Color Light "R" Connected to Battery Negative(-)
- Blue Color Light "B" Connected to Battery Negative (-)
- Purple Color Light "R" and "B" Connected to Battery Negative(-)
- Yellow Color Light "R" and "G" Connected to Battery Negative (-)
- Cyan Color Light "B" and "G" Connected to Battery Negative (-)

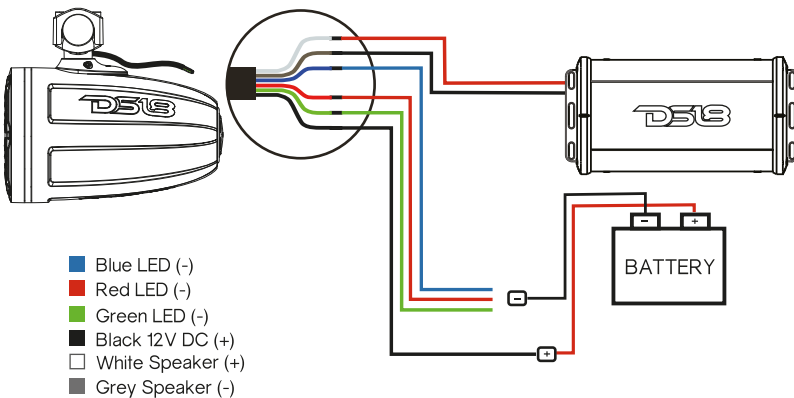

INSTALLATION

BEGINNING MOUNTING

Step 1: Remove tower speakers from the packaging and ALL hardware.

Step 2: Find a GOOD location that allows for easy wiring of the speaker (and LED lights) - PLUS does NOT impair your movement around the location.

Step 3: Using the supplied 6mm hex wrench spin out the 4-M8 screw that hold the top clamp

Step 4: Drill $\varnothing 15 - \varnothing 20$ mm hole on mounting tube bottom align the clamp wire out hole.

Step 5: Connect the speaker wire AMP out and LED controller, Insulated lock the clamp to tube.

Step 6: Cut the length of rubber pad and wires outlet according to the diameter of installation pipe.

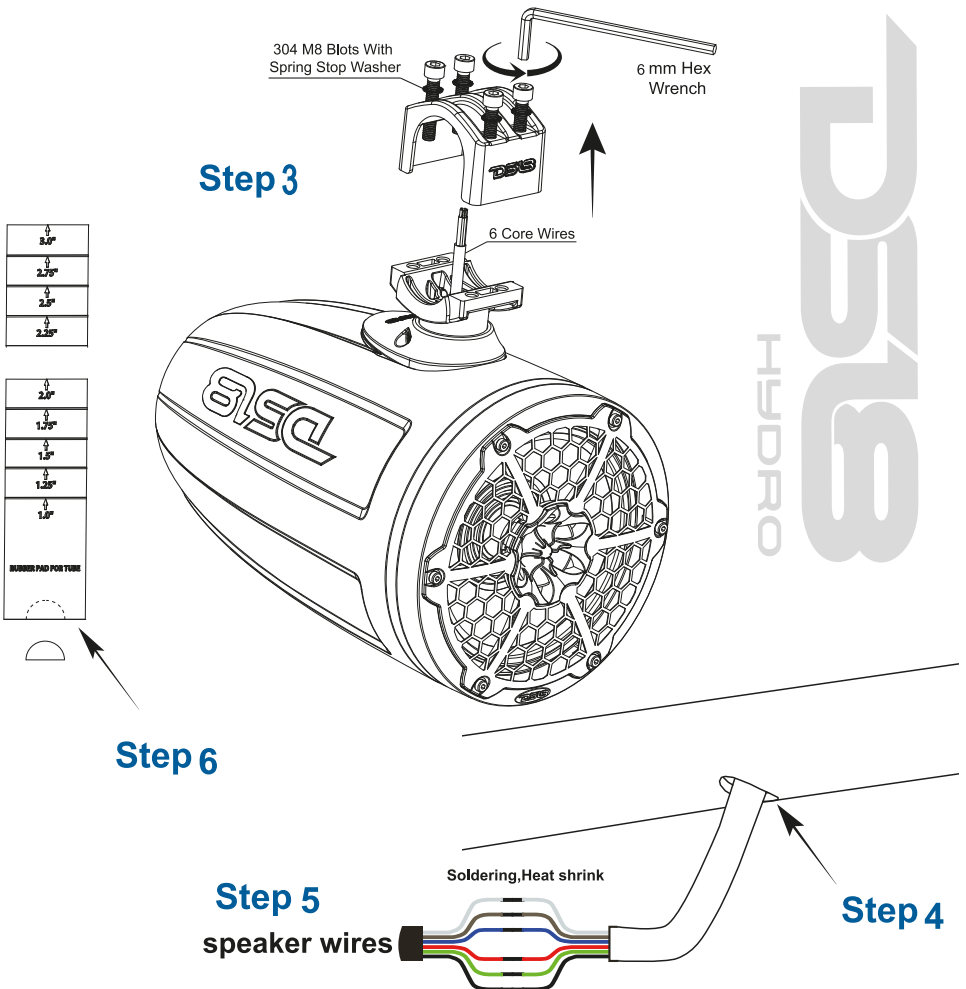

Step 7: Wrap the rubber pad around the pipe and align wire out hole According to the diagram.

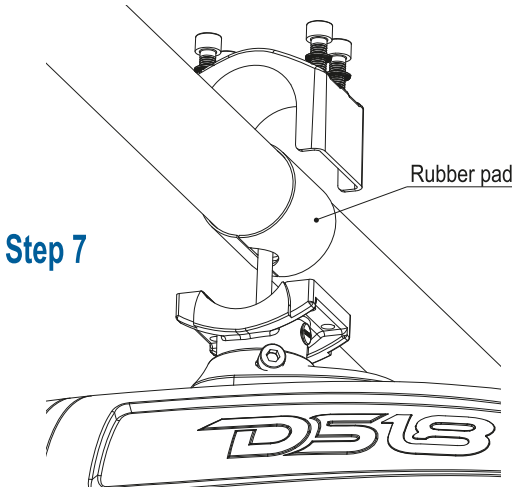

Step 8: Push the wire into the tube, press on the rubber pad, and lock the top clamp.

Step 9: Take down the safety rope and hang it on the pipe, lock the screw gasket safety rope lifting ring on the clamp base, and apply screw fastening glue on the screw before locking.

Step 10: If need be, rotate the speakers for best dispersion, this easily done by locating the 6mm&4mm hex wrench set screw on the side of the clamp base, rotate the speaker / enclosure to the desired angle, once there ... locking the screws tight, Avoid vibration, clamp loose!!!

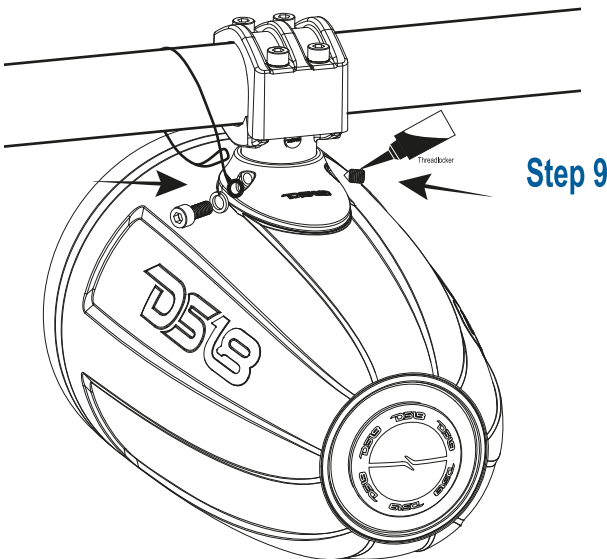

INSTALLATION

Step 11: During the mounting process you should have located the spot to drill your tower bar for the 6 conductor wire (Speaker and RGB lightning wiring) insertion. Or NOT (see Tie-wrap solution below)

Step 12: Remove Wire NBR Plug and Slide the wire thru the hole Snake the wire down to the bottom of the tower tube in a location that the wires can be attached to the audio (And lighting) system. Solder or butt connect the speaker wire coming from the tower to the speaker wire to the system. Then heat-shrink it for added protection from water / moisture.

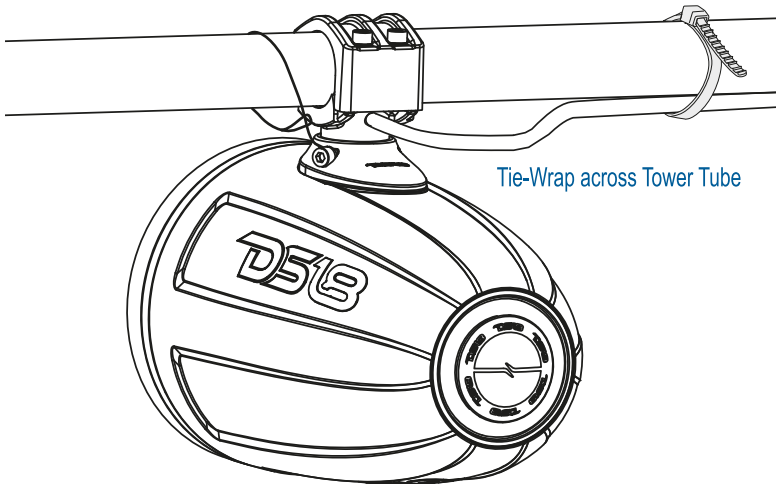
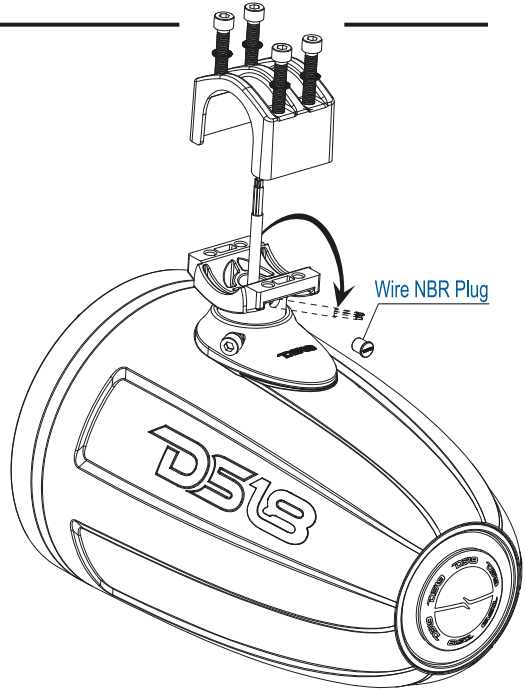

Step 13: When you want to install by flat mounting, remove the clamp and take out the 6 core through it into flat mounting bracket, then assemble it , see depiction below.

FRONT LOGO CAN ROTATION

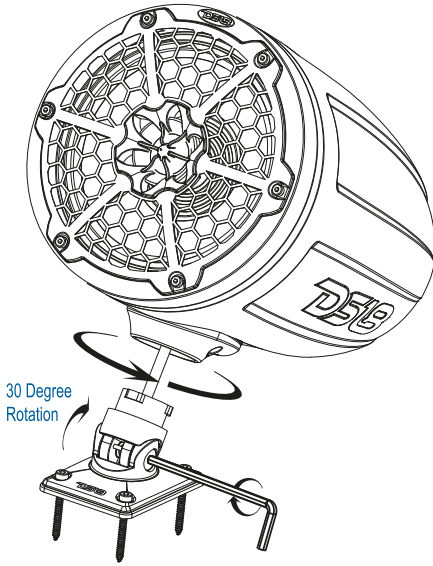

FLAT MOUNTING

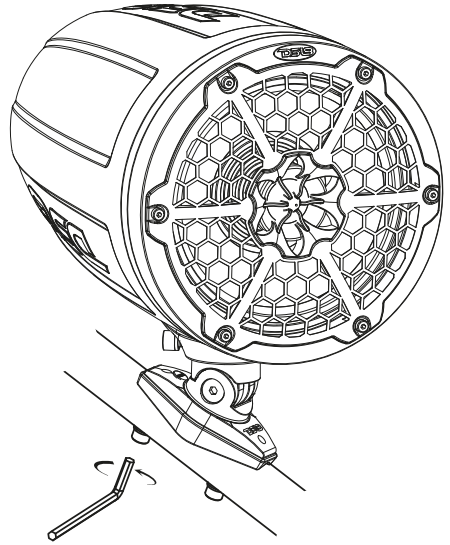

TUBE MOUNTING



FOR MORE INFORMATION
PLEASE VISIT
DS18.COM

WE LIKE IT LOUD

The DS18 logo, featuring the letters "DS18" in a bold, stylized, sans-serif font. The "D" and "S" are connected, and the "18" is separate. A registered trademark symbol (®) is located to the upper right of the "8".

DS18[®]