

BOAT TRAILER WINCH

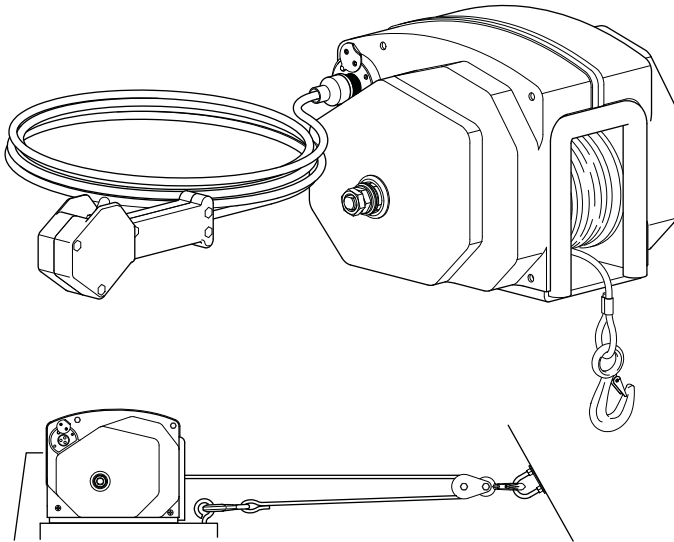

Setup with double line pull (pulley block)

pw915101

- ◆ 12 Volt Powered Winch
- ◆ Power-In / Power-Out Operation
- ◆ Hand Held Wired Remote Control



Thoroughly read the manual furnished with this product and be familiar with the controls. Do not allow individuals to operate the winch without understanding the safe operation and procedures for the equipment.

PROPRIETARY STATEMENT

The *Powerwinch* Trailer Winch is a product of Scott Fetzer Electrical Group or SFEG, located in Fairview, Tennessee, USA. The information contained in or disclosed in this document is considered proprietary to SFEG. Every effort has been made to ensure that the information presented in the document is accurate and complete. However, SFEG assumes no liability for errors or for any damages that result from the use of this document.

The information contained in this manual pertains to the current configuration of the models listed on the title page. Earlier model configurations may differ from the information given. SFEG reserves the right to cancel, change, alter or add any parts and assemblies, described in this manual, without prior notice.

SFEG agrees to allow the reproduction of this document for use with SFEG products only. Any other reproduction or translation of this document in whole or part is strictly prohibited without prior written approval from SFEG.

TABLE OF CONTENTS

Safety Information	iii
Specifications	iv
Winch Specifications.....	iv
Approximate Rolling Load Capacities (values are in pounds).....	iv
Winch & Boat Capacities (values are in pounds).....	iv
Mounting the Unit	1
Mounting the Unit.....	1
Wiring the Unit	2
Pulley Block	3
Assembly Instructions:.....	3
Double Lining the Winch.....	3
Operating the Winch	4
Unloading The Boat.....	4
Loading the Boat.....	4
Emergency Hand Crank.....	5
Maintenance	5
Lubrication.....	5
Adjusting the Brake.....	6
Replacing the Cable.....	6
Troubleshooting Guide.....	7
Replacement Parts List	8
Warranty	10

SAFETY INFORMATION

The following Safety Precautions Must be Followed at ALL Times. Failure to follow the warnings and cautions in this manual could result in serious injury and/or property damage.

 **WARNING** ALWAYS unplug the wiring harness before attempting to install, relocate, service or perform maintenance on the winch.

 **WARNING** NEVER use the winch to lift or move people or animals.

 **WARNING** NEVER use the winch for overhead lifting.

 **WARNING** NEVER attempt to pull a load greater than the rated load of the winch.

 **WARNING** NEVER use the winch to exclusively hold, support or permanently secure the load. Use separate straps to support the load.

 **WARNING** ALWAYS stand away from the winch during operation. ALWAYS stand clear of the area behind and between the load and the winch. Serious injury could occur if the cable breaks.

 **WARNING** NEVER wear loose fitting clothes, scarves, ties or jewelry when operating the winch. Loose clothing can become caught in moving parts.

 **WARNING** ALWAYS block the vehicle wheels to help prevent the vehicle from moving when pulling a load with the winch.

 **CAUTION** ALWAYS use the recommended cable. Never substitute rope for cable.

 **CAUTION** ALWAYS keep hands clear of the cable spool (drum area).

 **CAUTION** ALWAYS wear leather gloves when handling the cable.

CALIFORNIA PROPOSITION 65

 **WARNING** This product contains chemicals known to the state of California to cause cancer or birth defects or other reproductive harm. California's Proposition 65 requires this warning to be given to customers in the state of California.

SPECIFICATIONS

Various load conditions affect winch performance. The line pull required for a specific application depends on the weight of the load, condition of the trailer rollers, and the degree of the loading ramp incline. The charts below are based on a single line pull and provided as a guideline in calculating pulling capabilities.

⚠ WARNING The cable fasteners on this or any winch are not designed to hold rated loads independently. Always leave a minimum of five wraps of cable on the drum to achieve the rated load values.

Winch Specifications

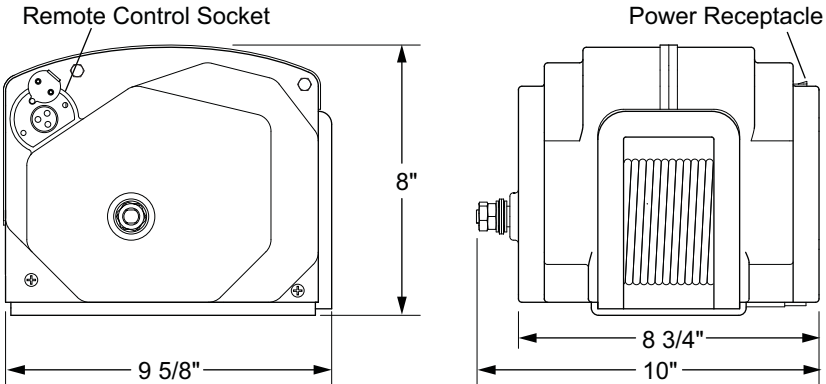

pw915016

Line Speed @ Capacity (FPM)	Gear Ratio	Voltage	Circuit Breaker	Unit Weight
10	450:1	12VDC	60 amps	40 lbs

Approximate Rolling Load Capacities (values are in pounds)

% Incline	Level	5%	10%	20%	30%	50%	70%	100%
° Incline	0°	3°	6°	11°	17°	26°	35°	45°
	32000	20010	15060	10200	7830	5580	4590	3870

- A 10% incline (6°) is 1 foot rise in 10 feet.
- To convert from pounds (lbs) to kilograms (kgs) divide by 2.2.
- Capacity can be increased by using a pulley block.

Winch & Boat Capacities (values are in pounds)

Vertical Lift Capacity	Double Line Pull	Approximate Boat Weight*	Approximate Boat Size*
3200	5900	9500	22-29 Feet

* Boat size and weight is approximate and varies depending on boat type. When calculating boat weight, use the fully loaded weight that includes boat, motor, fuel, water, gear etc.

MOUNTING THE UNIT

MOUNTING THE UNIT

The following instructions are for standard mounting of the winch. A quick mount kit is available (p/n P7700000AJ). If installing with the quick mount kit, follow the directions with the kit. Steps 3, 4 and 6 apply when using the kit.

The winch can be mounted on the trailer in the same position and location as an existing hand winch.

1. Remove the existing hand winch.
2. Position the unit on the trailer mount stand.
3. Confirm that the winch's cable hook and the bow eye on the boat are at the same height when the boat is in the fully loaded position on the trailer.
If the bow eye is too high, extra pull is required of the winch and extra stress is exerted on the boat's stern and bow eye.
If necessary to create equal height, raise or lower the winch stand. In most cases, trailer manufacturers have adapters available for use with a winch.
4. Confirm that there is a minimum of 12 inches clearance between the winch and the bow eye when the boat is in the fully loaded position. If necessary, extend the bow stop to obtain the clearance.
5. Bolt the unit using a minimum of two (2) 3/8" grade 5 machine bolts and lock nuts. If the existing mounting holes do not line up with the winch, use the bottom of the winch as a template and drill two (2) 7/16" holes in the mounting surface of the trailer stand.
6. If using a double line pull (using a pulley block), install a 3/8" eyebolt on the stand as close as possible to the base of the winch. See illustration on page 3.

WIRING THE UNIT

! WARNING ALWAYS disconnect the battery before working on electrical equipment.

! WARNING ALWAYS use the recommended wire size and rated circuit breakers. Failure to use the furnished and recommended sizes can cause a fire hazard and void warranty.

NOTICE When routing the wiring, avoid sources of heat.

NOTICE When routing the wiring, avoid sharp edges that can cut or fray the wire insulation.

The following instructions are for permanently wiring the winch. Two additional wiring kits are available and sold separately: A universal bumper wiring kit (p/n P7702101AJ) and a quick connect wiring harness (p/n P7866000AJ) for temporary connections. If installing one of the kits, follow the directions with the kit.

1. Attach the circuit breaker to the battery's POSITIVE (+) post or positive (+) terminal of the starter solenoid.
2. Attach the ground wire (black) to the vehicle frame. Clean the metal frame with a wire brush or equivalent then attach the ground lug using a 5/16" bolt and lock nut (bolt and nut not furnished).
3. Route the wire under the vehicle and along the frame. Avoid sharp edges and moving parts. Secure the wire to the frame approximately every 18" using nylon ties or equivalent.

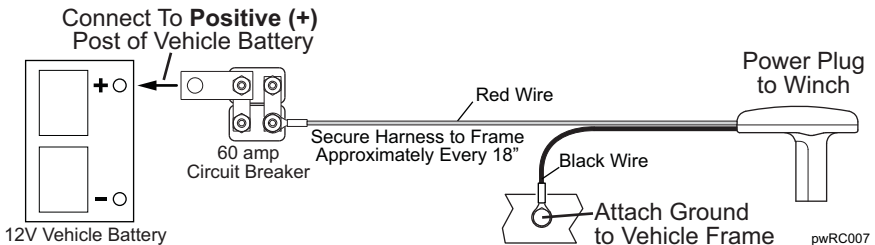

PULLEY BLOCK

The pulley block can increase the pulling capacity approximately 55%.

Assembly Instructions:

1. Place the two screws through one of the tear drop plates and hold in place.
2. Slide a bushing over each screw.
3. Slide the pulley wheel and hook over the bushings as shown. The components fit loosely on the bushings.
4. Wrap the cable around the pulley.
5. Place the second tear drop plate over the screws and secure using the washers and nuts provided.
6. Mount an eyebolt next to the winch. The eyebolt should be mounted as close to the winch as possible. Eyebolt is furnished by the installer.

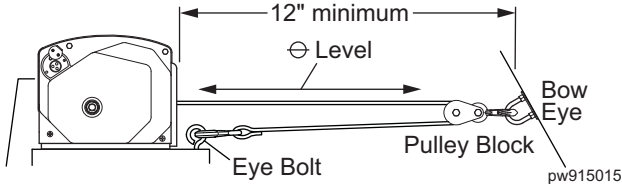
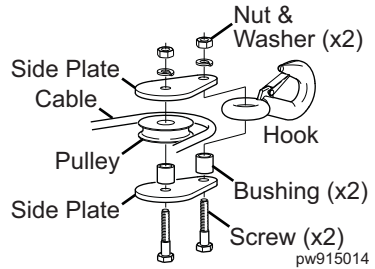

Double Lining the Winch

1. With the cable threaded through the block, hook the pulley block to the eye on the bow.
2. Power out the cable and attach the cable hook to the eyebolt next to the winch.
3. Power in the cable.

OPERATING THE WINCH

! WARNING To avoid personal injury and property damage, clear the area around and behind the boat of people, animals and obstructions before loading or unloading the boat.

! WARNING Never stand between the load or anchor point and the winch. Serious personal injury could occur if the cable breaks.

! WARNING NEVER use the winch alone to secure the boat to the trailer during transit. Use separate straps or equivalent to secure the boat to the trailer.

NOTICE ALWAYS wear leather gloves when handling the cable. Steel cable can cause serious damage to hands.

UNLOADING THE BOAT

1. In not previously done, attach the winch cable hook to the bow eye on the boat.
2. Connect the power to the winch. The plug goes into the socket on the right side of the winch.
3. Connect the wired remote. The plug goes into the socket on the left side of the winch.
4. Remove the tie down straps from the boat.
5. Using the switch on the remote, power out the cable until the boat is unloaded.
6. When the boat is in the water, release the cable hook.

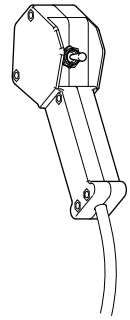

pw915017

7. While maintaining tension in the cable, press the switch on the remote. Roll the cable up completely. Do NOT allow the cable to roll up loosely, damage to the cable and winch components could occur.

NOTICE Do not allow the cable hook to roll into the winch. Damage to the level wind plate can occur.

8. Secure the cable hook to prevent any accidental injury or damage.

LOADING THE BOAT

1. Connect the power to the winch. The power cord plug goes into the socket on the right side of the winch.
2. Connect the wired remote. The plug goes into the socket on the left side of the winch.
3. Align the boat and trailer.
4. Power out the cable and attach the cable hook to the bow eye.
5. Step clear of the cable, winch and boat.
6. Press and hold the remote switch. Power in the cable until the boat touches the bow stop. Release the switch.
7. When fully loaded, secure the boat to the trailer.

EMERGENCY HAND CRANK

An emergency hand crank is available when there is no power (i.e. a dead battery).

⚠ WARNING Never use the hand crank to assist a running motor. Serious personal injury can occur.

1. Disconnect the power cord from the winch.
2. Remove the two jamb nuts from the shaft on the left side of the winch.
3. Place the emergency handle onto the shaft and secure to the shaft with the one of the nuts removed previously. Tighten the nut snugly against the handle.
4. Turn the crank handle clockwise to wind in the cable.
5. After the boat has been secured on the trailer, remove the handle from the shaft. Replace the nuts on the shaft. It may be necessary to adjust the brake tension before using the winch again. Refer to page 5.
6. Store the handle.

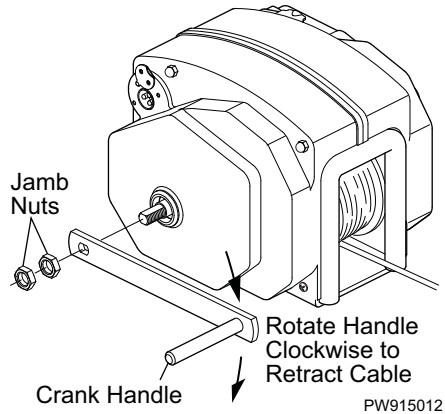

⚠ CAUTION Remove all tools used for manual override operation before operating the winch with the electrical power.

MAINTENANCE

LUBRICATION

The following steps should be performed a minimum of once a year or when the unit is placed in storage.

Cable: Lubricate the cable with Whitmore's Wire Rope Spray, WD40 or equivalent. Spray the shaft and the cable as the cable is being wound.

Gears: Remove the covers and lubricate the gears with a lithium base grease. Be careful not to get grease on the clutch lining (refer to figure on page 8).

ADJUSTING THE BRAKE

The winch is equipped with a friction brake that holds the load when the power is off. The brake requires adjustment if the load creeps while the power is off or if the brake slips while powering the load in or out.

1. Disconnect the boat from the winch.
2. Locate the jamb nuts on the left side of the winch.
3. Loosen the outer jamb nut.
4. Turn the inner jamb nut clockwise to increase the load capacity or counterclockwise to decrease the load capacity. The inner nut must be tight enough to prevent the load from slipping or creeping.

NOTICE Do not over tighten the inner nut. Over tightening the inner nut can shorten the motor life.

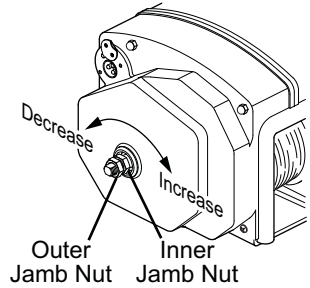

PW915013

5. Tighten the outer nut against the inner nut.

REPLACING THE CABLE

WARNING Always use the exact Powerwinch replacement cable (p/n P7188800AJ). Winch rating and cable strength are matched for safe and optimum performance. NEVER replace the cable with rope.

CAUTION ALWAYS wear leather gloves when handling the cable. Steel cable can cause serious damage to hands.

1. Power out the cable. Disconnect the power cable after the cable is fully out.
2. Cut the old cable off approximately 2" from the cable drum.
3. Slide the collar away from the cable then push the old cable out of the drum.
4. Insert the new cable through the shaft. The cable must be inserted through the side opposite the counter bore.
5. Insert the stop sleeve over the end of the cable until the cable is flush with the end of the stop. Solder or crimp the stop onto the cable.
6. Pull the cable back through the shaft until the stop is seated in the counter bore.
7. Slide the collar around the cable. The notch on the collar fits around the cable.
8. Reconnect the power harness to the unit. Power-in the cable, keeping tension on the cable as it is winding. The cable must wind from the bottom of the cable spool.

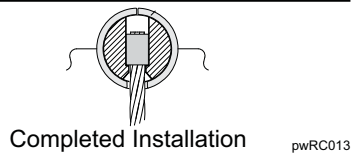
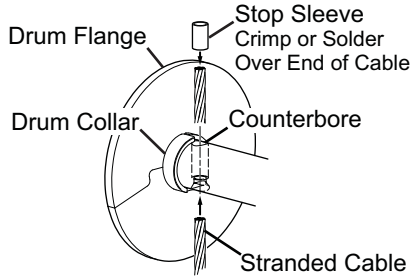

NOTICE If the cable is not wound correctly, it may cause loss of power and risk damage to the level wind plate. If the cable is not correct (too loose or wound on one side), unwind the cable then rewind while keeping tension on the cable.

TROUBLESHOOTING GUIDE

WINCH DOES NOT OPERATE		
A.	Confirm power to winch 1. Check vehicle battery is fully charged 2. Confirm connections are for tight & clean. 3. Check wires are worn or bare that may cause shorts	Correct as required.
B.	Check circuit breaker at battery Bypass circuit breaker and test winch. Does the winch run? <div style="border: 1px solid black; padding: 5px; display: inline-block; margin-top: 10px;"> NOTICE Do not operate the winch without the circuit breaker. Removing the CB from the circuit is ONLY for testing. </div>	YES If winch runs, circuit breaker is bad, replace. NO Reconnect circuit breaker. Contact your authorized service center.

LOAD SLIPS

The winch is equipped with a friction brake that hold the load when the power is off. The brake requires adjustment if the load creeps while the power is off or if the brake slips while powering the load in or out.

A.	Load slips during retrieval	Thrust washers and thrust bearings are worn or deformed. Replace
B.	Load slips back after boat is retrieved	Clutch bearing inside the 120 gear has failed. Replace gear assy
C.	Check clutch lining The clutch lining is located on the 120 tooth gear under the LH (clutch side) of the case. Ensure that the clutch is clean free of grease.	Clean as required. If clutch lining is worn or damaged, replace the 120 tooth gear assembly.

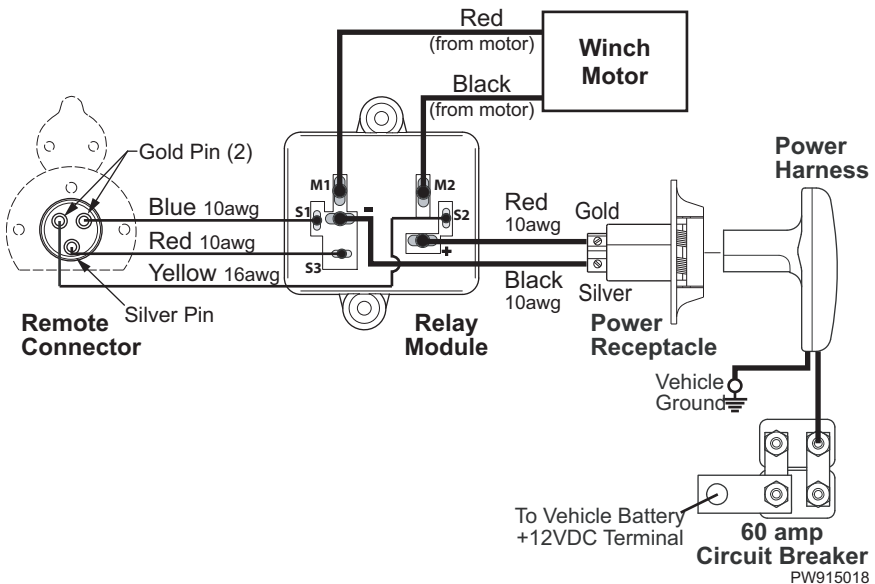

REPLACEMENT PARTS LIST

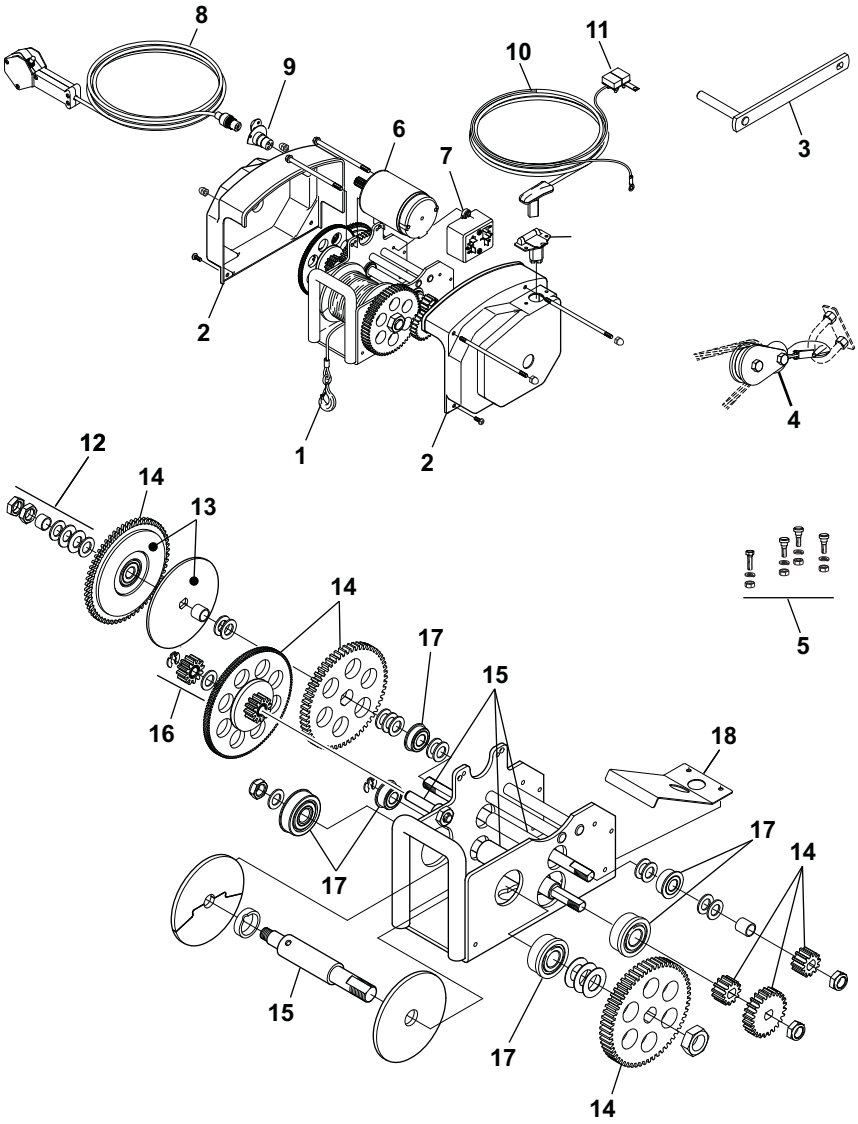

pw915501

<i>Item</i>	<i>Description</i>	<i>Description</i>	<i>Notes</i>
1	P7188800AJ	Cable Assy, 7/32" x 40'	
2	R001304	Cover Kit	1
3	P5594700AJ	Emergency Hand Crank	
4	P7904300AJ	Pulley Block Kit	
5	P7700000AJ	Quick Mount Kit	
6	R001310	Motor Assy	
7	R001487	Relay Module	1
8	R001305	Remote Control Assy	
9	R001309	Socket Kit	
10	P7830201AJ	Power Harness	
11	P7837300AJ	Circuit Breaker, 60amp	
12	R001298	Clutch Washer Kit	
13	R001297	Clutch Pad Kit	
14	R001303	Gear Kit	
15	R001306	Shaft Kit	
16	R001299	Locking Gear Kit	
17	R001289	Bearing Kit	
18	R001288	Level Wind Kit	1
19	R001486	Fastener Kit	2

- Notes:**
1. Fasteners are included with kit.
 2. Fasteners and washers not indexed on illustration are part of the fastener kit (item 19).