

# PoE4v2

Wide DC Input Voltage Range PoE Injector

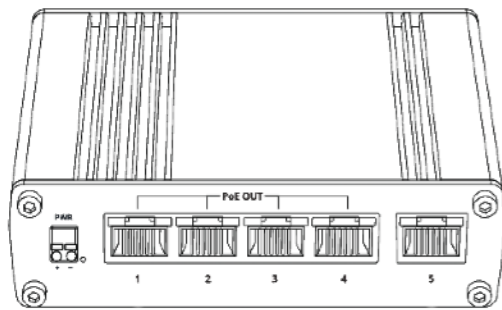

## QUICK START GUIDE

Thank you for choosing the PoE4v2 Power over Ethernet (PoE) Injector Hub from Iris Innovations.

This document is designed to provide a brief overview of the product, its features and installation instructions. Full instructions, regulatory and safety information can be downloaded from our website: [www.boat-cameras.com](http://www.boat-cameras.com)

Iris offer a range of network power injectors to complement our extensive portfolio of rugged IP CCTV cameras and network equipment. The PoE4v2 has been designed

### Rugged & Compact

With its stylish and compact form factor, the PoE4v2 chassis is manufactured from an extruded aluminium design with high quality and rugged industry standard connectors, designed for reliable operation throughout its life.

### Plug & Play

The PoE4v2 Injector is a Plug and Play device with no configuration or setup required. Simply connect your network cables as required, apply DC power and you're good to go!

The PoE4v2 operates over a wide DC input range of 9 ~ 30VDC.

### Operation

The PoE4v2 Power over Ethernet Injector Hub features 4 powered ethernet ports and a passive 'uplink' port. Each port is capable of delivering power up to 30W per port with a maximum power budget of 60W. Therefore, if 4 devices are connected, the maximum power for each port will be 15W.

The PoE4v2 is IEEE802.3af / 3at compliant.

# PoE4v2

Dimension Drawing

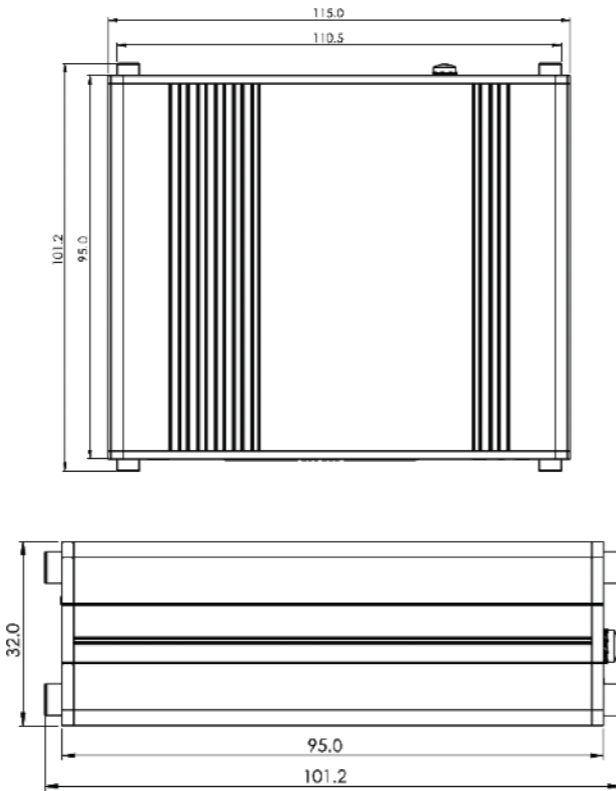

## What's in the Box?

The following parts are included with your PoE4v2

- 1 x PoE4v2 Power Injector
- 1 x 2 Core Power Input Cable
- 1 x Quick Start Guide

## Installation

Ensure the device is installed in a clean, dry environment away from excess heat sources, moisture and excessive vibration.

Before you fix the PoE4v2 into position, take time to ascertain there is sufficient space around the unit to allow ventilation and to take into account cable strain relief.

The PoE4v2 can either be screwed into place using a surface mounting kit (optional) or, due to its very light weight, fixed using strong Velcro pads. Do not drill through the unit.

Connect the power connector supplied ensuring the correct polarity is observed. The power connectors are push-pin type. Use a small flat bladed screw driver to push in the tab on top of each terminal and hold, insert each power cable ensuring polarity is correct, fully into the terminal and then release the tab to grip the wire in place.

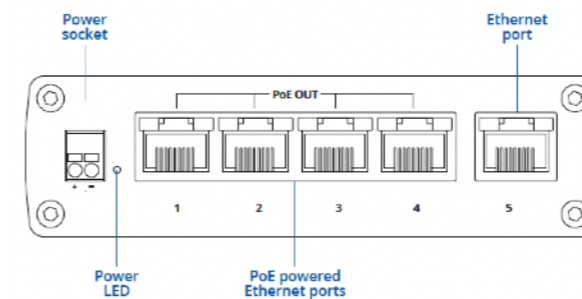
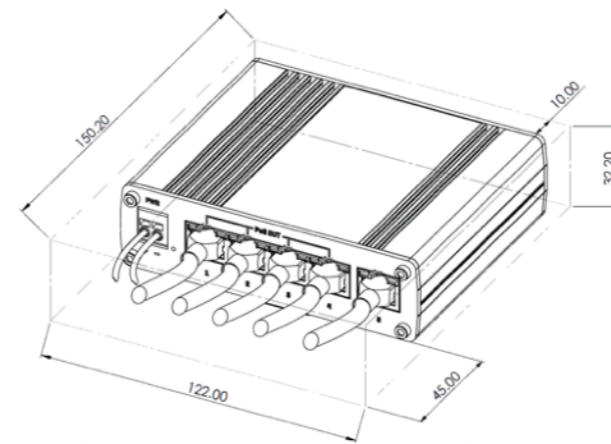

### LED MEANING

Orange LED on: link established 10/100/1000 Mbps  
Orange LED blinking: active connection

Green LED on: link established 1000Mbps

### POWER SOCKET PINOUT



Technical specifications	
Input voltage range	9 - 30 VDC
Max power consumption no PoE devices connected	<2.2 W
Max PoE power budget at PSE*	60 W
Max Ethernet cable length	100 m

\* Based on connected power source 24 V (max) @ 10 VDC for total PoE consumption. 30 W PoE per PoE port @ 1.00 W (max) @ 24 VDC for each PoE port.

## ESSENTIAL SAFETY NOTICES:

### Product Disposal and Recycling:

Dispose of this product in accordance with the WEEE Directive. The Waste Electrical and Electronic Equipment (WEEE) Directive requires the recycling of waste electronic and electrical equipment. Iris Innovations supports the WEEE policy and politely request you observe correct disposal methods. For further information on how to correctly dispose of this product please contact Iris Innovations. Please recycle unwanted packaging and documentation. The cardboard carton, all paper manuals and documents and the protective plastic bag in which the camera is shipped are widely recyclable. Please check with your local recycling plant for confirmation.

### EMC Guidelines:

This product is designed to be used as a power supply for a visual aid or part of a visual aid system and is not part of the vessels navigational system - even if used in conjunction with other on board equipment or third party systems - and is compliant with the EMC directive 2014/30/EC. The original Declaration of Conformity (DoC) is available from our website. The camera should not be installed on the ships helm or in close proximity to radio receiver equipment. We recommend the camera is installed no closer than 1m from any equipment transmitting or cables carrying radio signals - particularly VHF radios and associated equipment. The device needs to be powered from a clean DC Power Supply fitted with an adequately rated fuse to provide the necessary electrical protection in accordance with its operating power ratings.

### Water Ingress:

Disclaimer: This product has not been tested to environmental ingress protection levels (IP30 rating) and is therefore not for external use. It must be installed in a clean, dry environment in accordance with the instructions provided in this document. Any evidence of water or moisture damage will invalidate the product warranty.

Full product safety, warning and compliance information, including Declaration of conformity is available from [www.boat-cameras.com](http://www.boat-cameras.com)

## SELECTED SPECIFICATIONS:

Full specifications are listed in the complete product guide which can be downloaded from our website.

LAN	5 x RJ45 Ports, 10/100/1000Mbps, Compliant with IEEE 802.3, IEEE 802.3u, 802.3az standards, supports auto MDI/MDIX crossover
PoE Ports	Ports 1-4
PoE Standards	802.3af and 802.3at
PoE Max Power per Port	30W
Total PoE Power Budget	60W
Maximum Ethernet Cable Length	100m
Bandwidth (non blocking)	10 Gbps
Packet Buffer	128 KB
MAC address Table Size	2K Entries
Jumbo frame Support	9216 bytes
Connector	2 pin industrial push tab grip style
Input Voltage Range	9-30 VDC
Input Voltage Range for PoE	9-30VDC
Power Consumption	Idle: 0.8W / Max 2.2W / PoE Max 106W
Ethernet Ports	5 x RJ45 Ports, 10/100/1000 Mbps
Status LED's	1 x Power LED, 10 x Ethernet Status LED's (2 per port)
Grounding	1 x Grounding Screw
Case Material	Aluminium
Dimensions (W x H x D)	115 x 32 x 95 mm
Weight	354g
Operating Temperature	-40° C to +75° C
Operating Humidity	10% to 90% Non Condensing
Ingress Protection	IP30
Approvals	CE, REACH, RoHS, WEEE, UKCA, FCC, IC, CB, RCM, E-Mark
Standards	EN IEC 62368-1:2020+A11:2020 EN60945:2002 Section 9&10

Manufactured & Assembled in the United Kingdom



Iris Innovations Limited  
Unit 240 Ordnance Business Park, Aerodrome Road  
Gosport. Hampshire PO13 0FG. United Kingdom

Tel: +44(0)2392 556509 / email: [info@boat-cameras.com](mailto:info@boat-cameras.com)  
[www.boat-cameras.com](http://www.boat-cameras.com)