

FIG. 1

### HINGE AND TAB INSTALLATION

Affix hinges and tabs to backside of transom with No. 10 x 1" stainless steel screws, as in figure No.1 and No.2. The three inch 3" dimension, as shown in figure No.1 is approximate and may vary, BUT ALWAYS KEEP TABS AS FAR TO THE OUTER CHINE AS POSSIBLE. Hinge may be affixed to bottom of hull if practical.

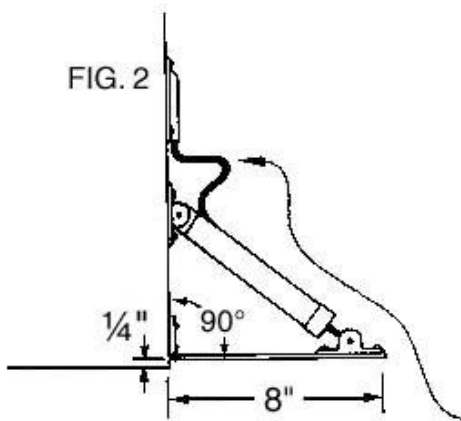

FIG. 2

### TAB BRACKET AND CYLINDER

Drop hex nut into recessed area on tab bracket, with lockwasher inserted on 5/8" s/s bolt. Come through underside of tab to contact nut and tighten with screwdriver to MAX.

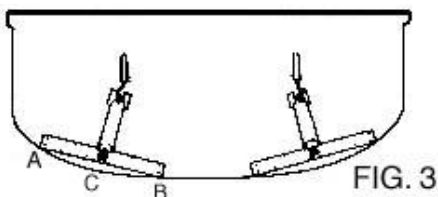

FIG. 3

### TRANSOM BRACKETS

Mount hinge and tab up from bottom of boat 1/4" as in figure No.2. Permit cylinder bracket to rest against transom, so that trailing end of tab is straight out or 90°. This 90° angle may vary according to transome design. Mark bracket holes, drill and affix bracket with No. 10x1" self-tapping screws.

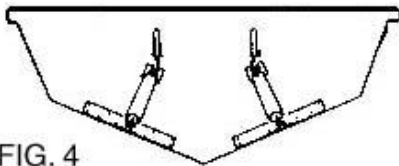

FIG. 4

### SIZE BIT

On fiber-glass, aluminum and steel hulls No.22 for a 5/32" hole wood use No.35 size bit for a 3/32" hole.

TRANSOME HOLE FOR HYDRAULIC HOSE: Drill 1/2" hole on 45° up angle 6" above waterline. Do not drill hole straight in, as this will kink hose when applying hose trim. CAUTION: Leave ample loop in hose at hydraulic cylinder as in figure No.2.

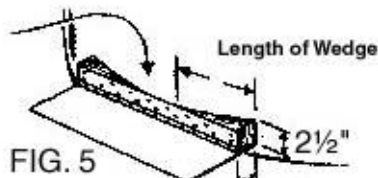

FIG. 5

### ELECTRIC HYDRAULIC MOTOR-PUMP

Mount motor-pump in VERTICAL POSITION AT ALL TIMES. Never fill above 3/4 level. It is desirable to mount motor-pump on inside of transom as in figure No.1, but as it is hydraulic it can be mounted in any convenient location. KEEP MOTOR-PUMP UP FROM BOTTOM OF BILGE SO AS NOT TO COM IN

## **PAINTING OF TABS**

In order to keep growth from cylinders and tabs, we recommend you see your local marine paint supplier for proper primer and anti-fouling paint

**Caution: Do Not Paint  
Cylinder Rams**

CONTACT WITH BILGE WATER OR WASHDOWN WATER.

### **HYDRAULIC HOSE**

Kit comes with one ample hose with hydraulic cylinder on each end. After locating mounting position of motor - pump, cut hose (they may be of unequal lengths) run loose ends through one half inch 1/2" transom hole onto barb type fittings protruding out from each side of motor pump cover. Tighten hose onto barb fitting with stainless steel clamps provided. **DO NOT OVERTIGHTEN CLAMPS.**

### **WIRING**

Connect color-code wires coming out of motor-to backside of switches-which are also color-coded.

**RED OR HOT LINE:** To get proper power, connect **DIRECT to BATTERY OR STARTER**

**GROUND:** Attach black wire to boat motor, being sure you have a good, clean, tight connection as short as possible

**FUESING:** Always use our 20 amp. In line in fuse which is attached to switches.

### **EXTRA SWITCH SET**

Color-code wires from lower switch station to fly-bridge switch.

### **TO BLEED**

After complete installation, work tabs up and down a few times, then while in the UP position, remove filler-plug located on front of oil reservoir , allow trapped air to escape, insert plug. If unit should ever need refilling use Insta-Trim Biodegradable oil or any type of automatic transmission fluid.

### **FIGURE No.3**

On round bottom boats, mount hinge at Point A and B as close to bottom of boat as possible. Disregard curvature at point C, as our hydraulic cylinder has a ram thrust of 2 3/4"which will bring tab in contact with water.

### **FIGURE No.4**

Mount it the same as in figure No.1 and No.2 Mount tabs on same angle as "V" of transform.

**CURVED TRANSOM:** Cut mahogany shims, as in

figure No.5

DOCKSIDE: When boat is at dockside, It is recommended to keep tabs extended.

WARRANTY: Any defective parts will be replaced on a "No Charge" basis, in a one-year period.

DEFECTIVE PARTS MUST BE RETURNED TO  
FACTORY PRE-PAID FOR OUR INSPECTION  
BEFORE REPLACEMENT. NO LABOR CHARGES  
WILL BE ALLOWED.